



CENTRAL PARK WEST

01 SITE PLAN
SCALE: 1/64" = 1'-0"

Upper West Side-Central Park West

Upper West Side-Central Park West
Historic District
Manhattan
Designated April 24, 1990

Historic District Boundaries



01 VIEW | WEST 83RD Ca. 1930'S

A AERIAL

MBB

Murphy Burnham & Buttrick Architects
48 West 37th Street, 14th Floor
New York, New York 10018
Telephone 212.768.7676
www.mbbarch.com

Congregation Rodeph Shalom
7 West 83rd Street
New York, NY 10024

Scale
NTS
Date
09.14.2017

LM 02

Building Photos

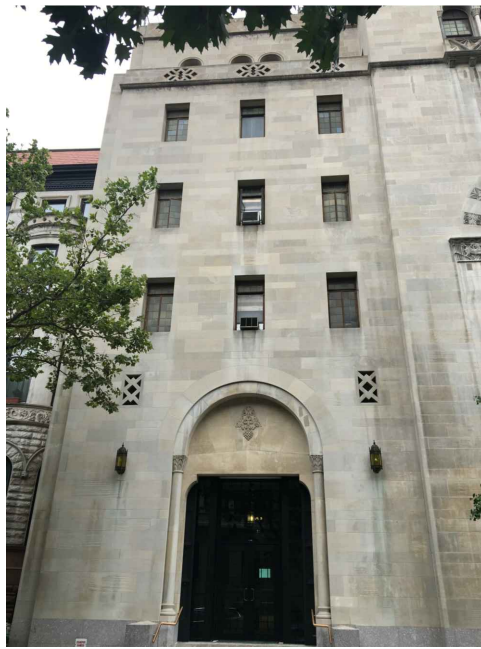

04 PRIMARY FACADE
VIEW OF EXISTING



05 PRIMARY FACADE
VIEW OF EXISTING



06 PRIMARY FACADE
VIEW OF EXISTING



07 PRIMARY FACADE
VIEW OF EXISTING

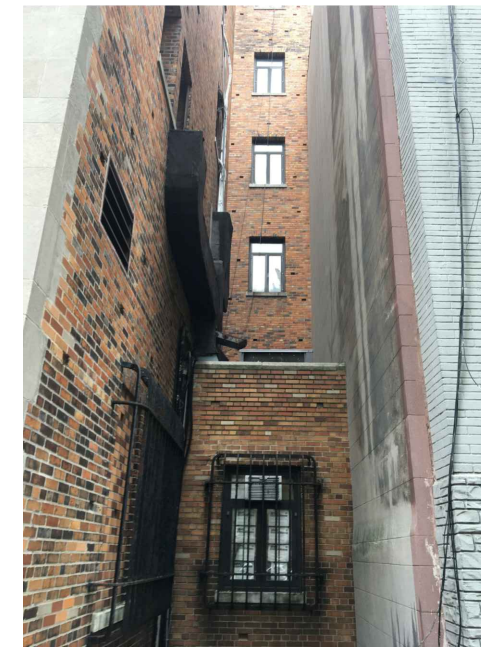

08 PRIMARY FACADE
VIEW OF EXISTING



02 NORTH ELEVATION
VIEW OF EXISTING



03 NORTH ELEVATION
VIEW OF EXISTING

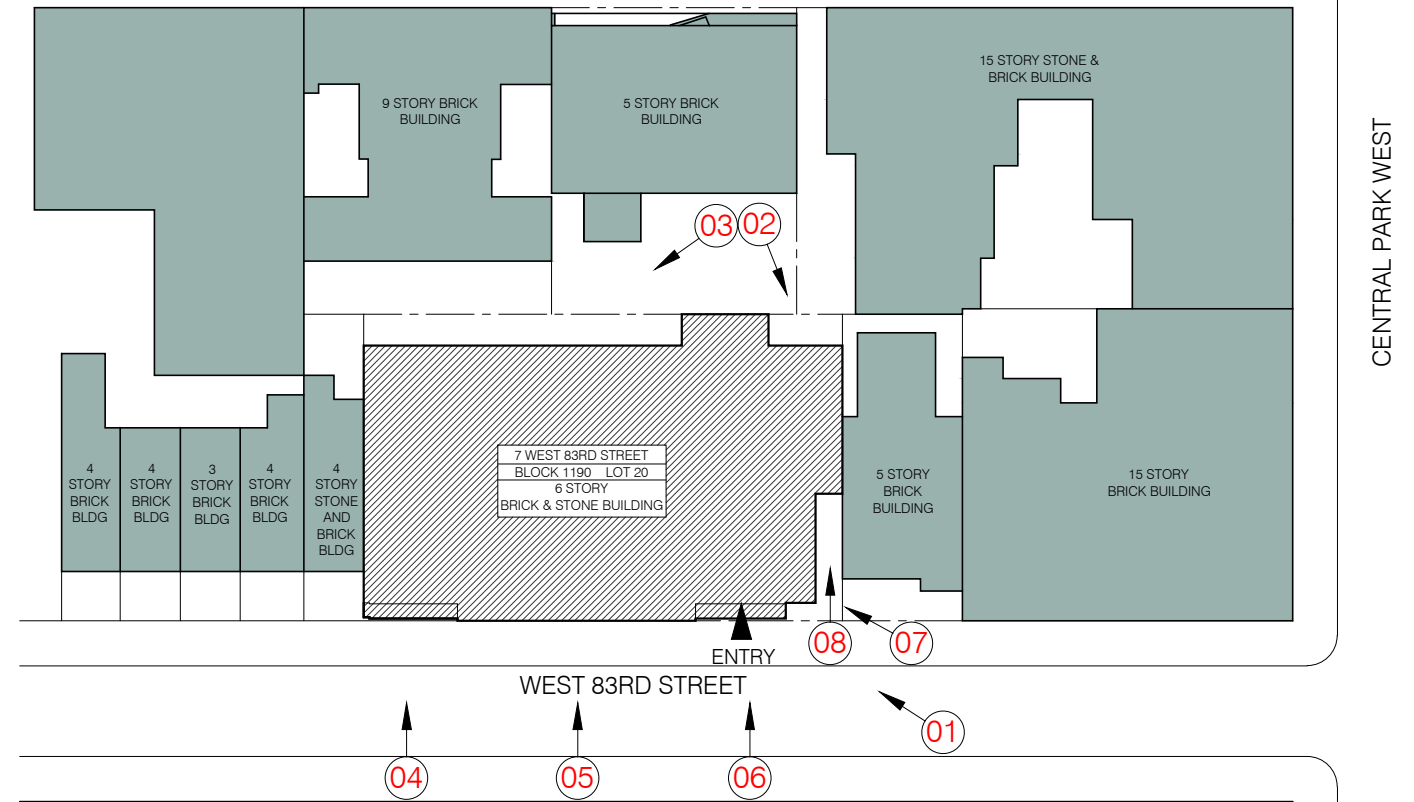

01 SITE PLAN
SCALE: 1/64" = 1'-0"

MBB

Murphy Burnham & Buttrick Architects
48 West 37th Street, 14th Floor
New York, New York 10018
Telephone 212.768.7676
www.mbbarch.com

Congregation Rodeph Sholom
7 West 83rd Street
New York, NY 10024

Scale
NTS
Date
09.14.2017

LM 03

Building Photos

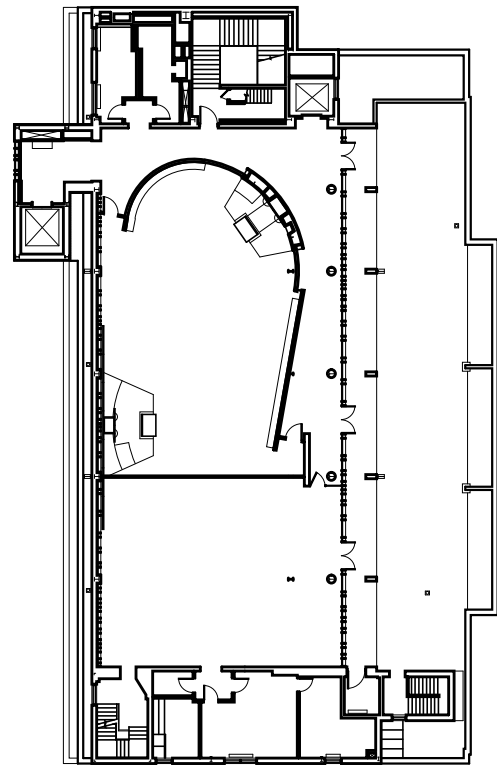

08 6TH FLOOR
SCALE: 1/32" = 1'-0"

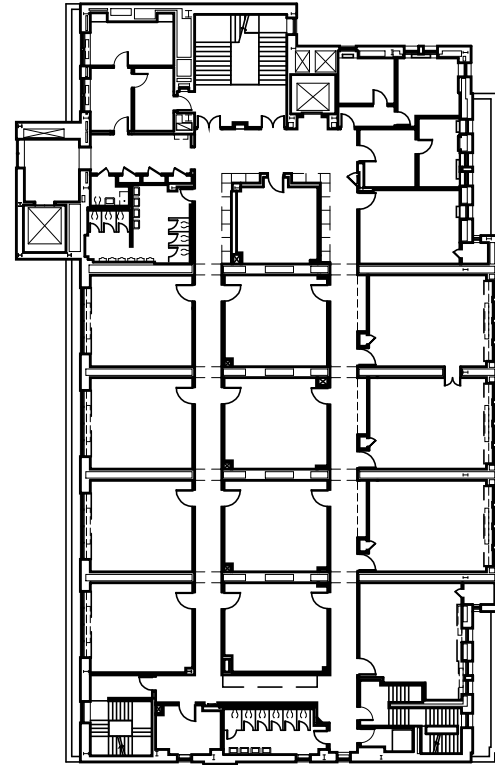

07 5TH FLOOR
SCALE: 1/32" = 1'-0"

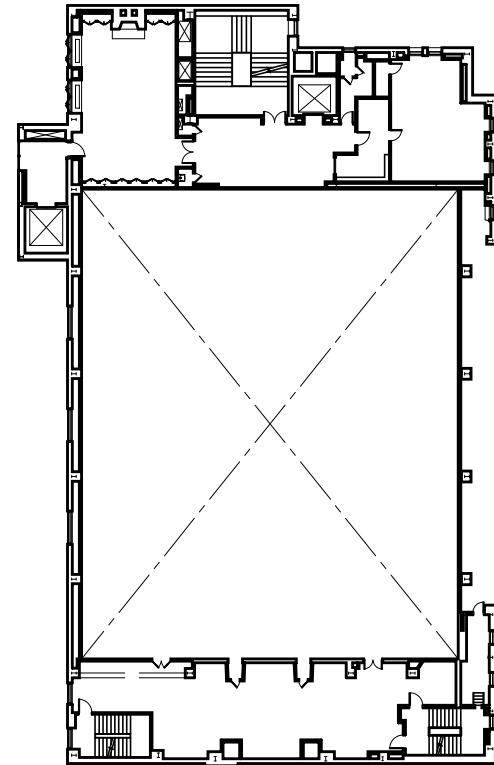

06 4TH FLOOR
SCALE: 1/32" = 1'-0"

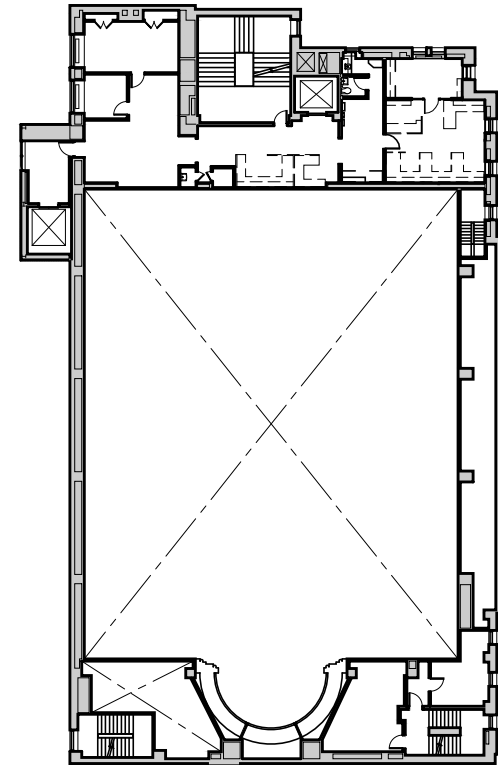

05 3RD FLOOR
SCALE: 1/32" = 1'-0"

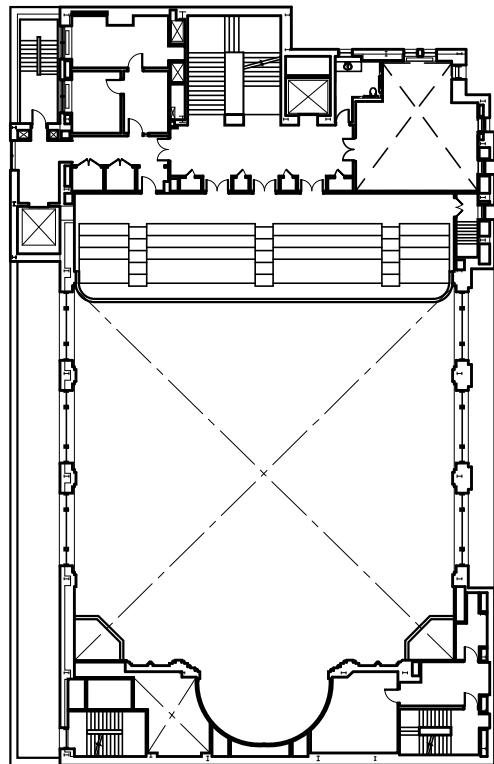

04 2ND FLOOR
SCALE: 1/32" = 1'-0"

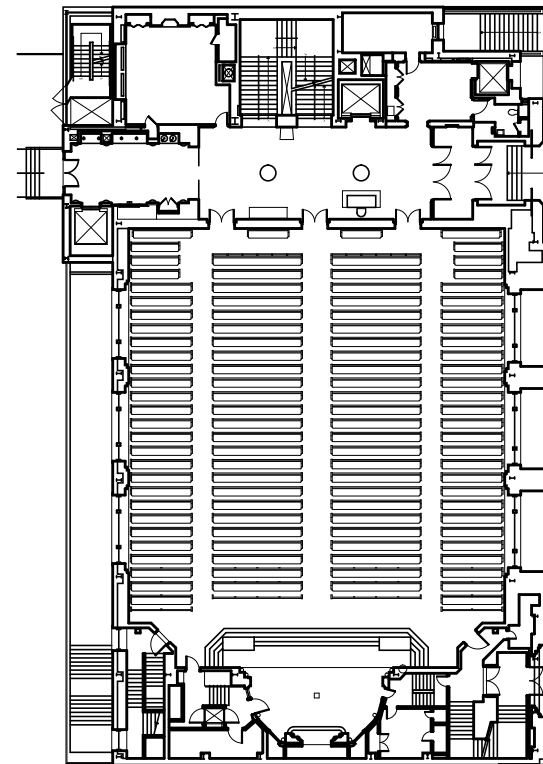

03 1ST FLOOR
SCALE: 1/32" = 1'-0"

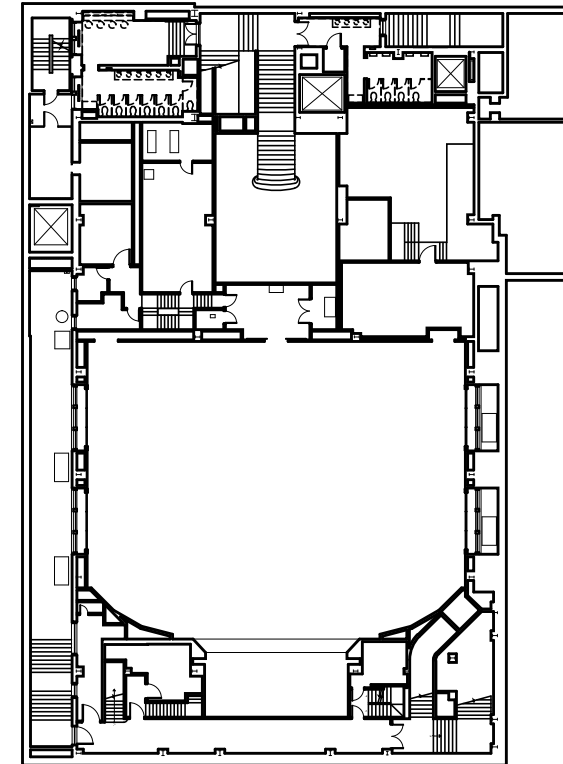

02 MEZZANINE
SCALE: 1/32" = 1'-0"

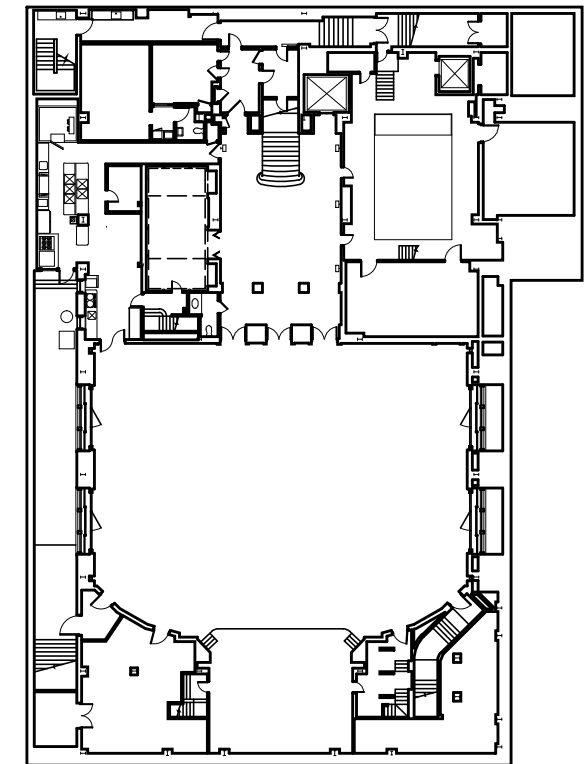

01 CELLAR
SCALE: 1/32" = 1'-0"

MBB

Murphy Burnham & Buttrick Architects
48 West 37th Street, 14th Floor
New York, New York 10018
Telephone 212.768.7676
www.mbbarch.com

Congregation Rodeph Shalom
7 West 83rd Street
New York, NY 10024

Scale
NTS

Date
09.14.2017
11.06.2017

LM 04

Existing
Floor Plans

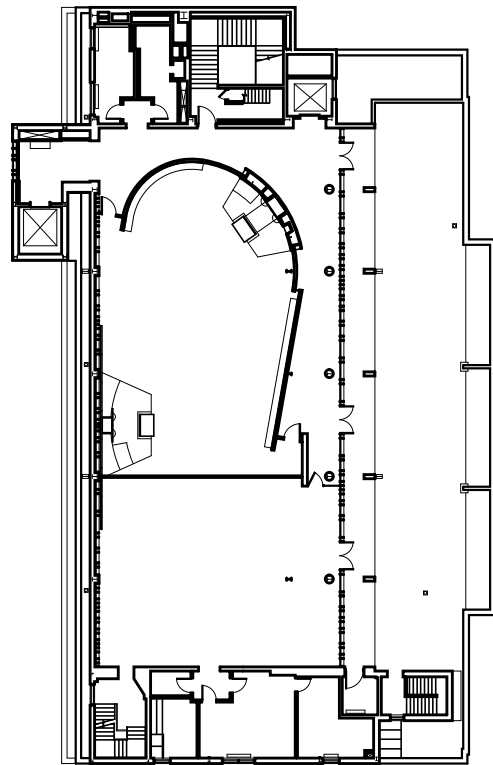

08 6TH FLOOR
SCALE: 1/32" = 1'-0"

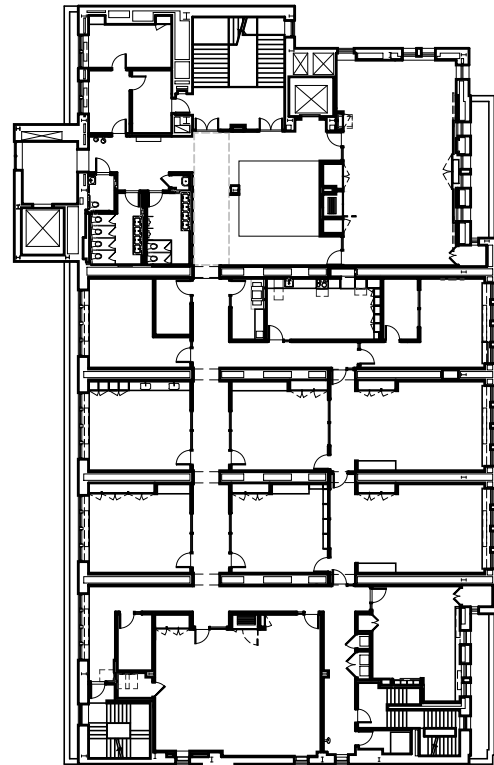

07 5TH FLOOR
SCALE: 1/32" = 1'-0"

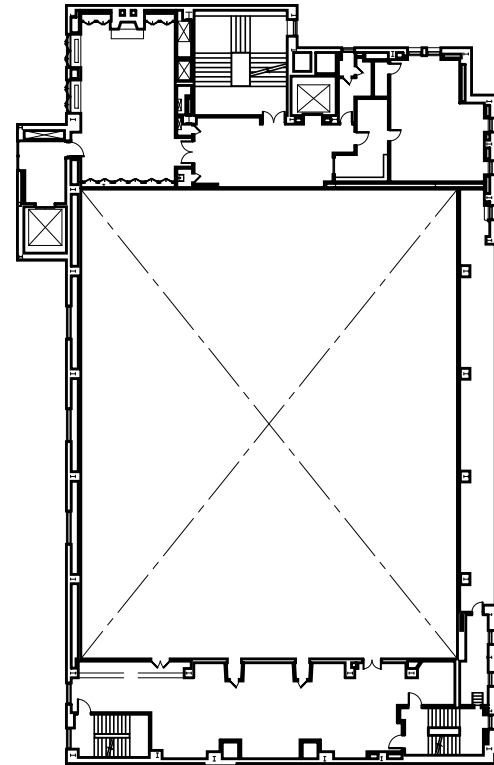

06 4TH FLOOR
SCALE: 1/32" = 1'-0"

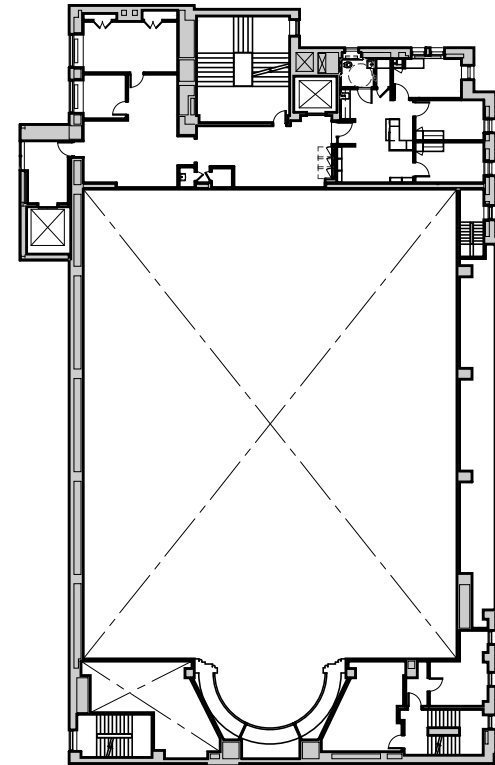

05 3RD FLOOR
SCALE: 1/32" = 1'-0"

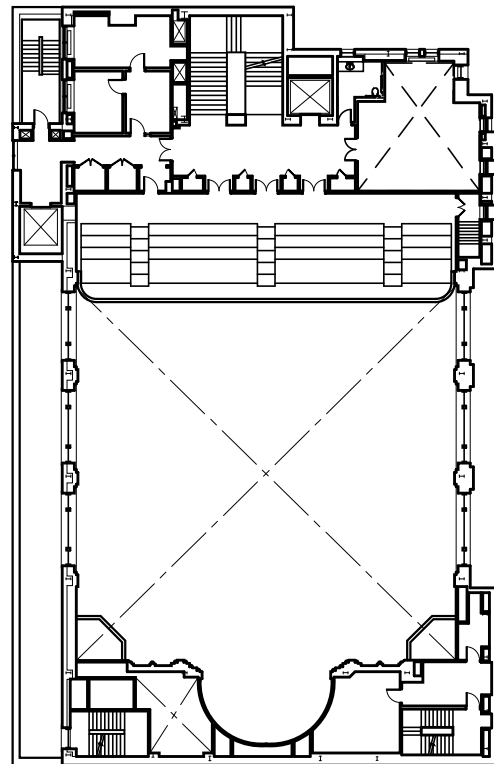

04 2ND FLOOR
SCALE: 1/32" = 1'-0"

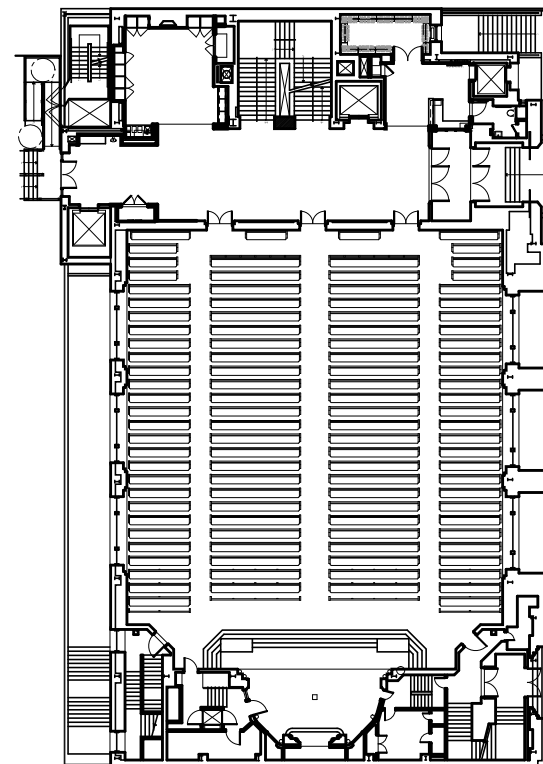

03 1ST FLOOR
SCALE: 1/32" = 1'-0"

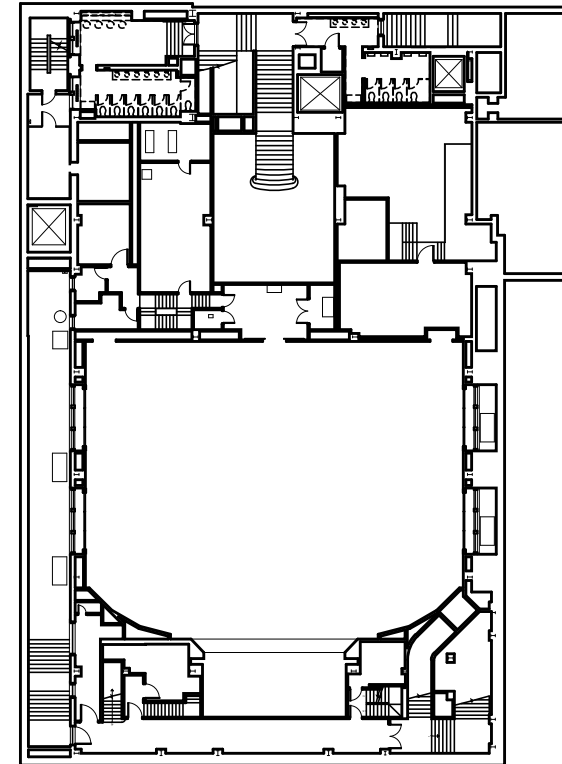

02 MEZZANINE
SCALE: 1/32" = 1'-0"

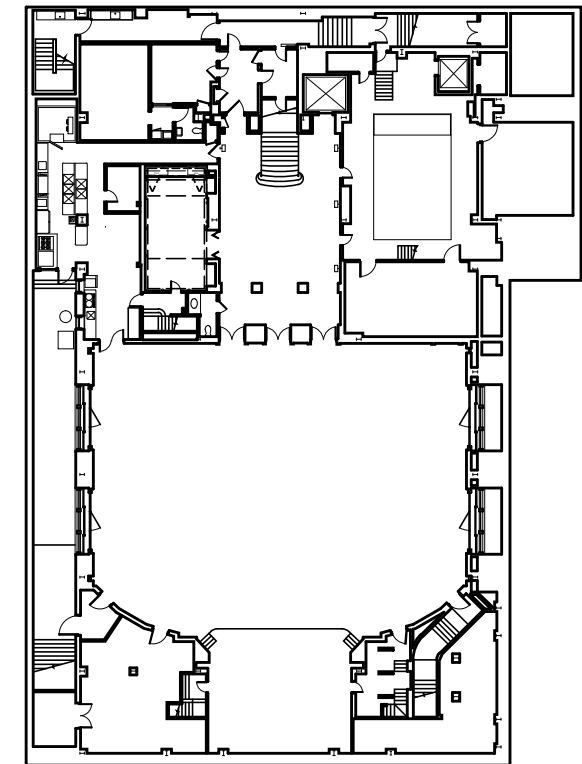

01 CELLAR
SCALE: 1/32" = 1'-0"

MBB

Murphy Burnham & Buttrick Architects
48 West 37th Street, 14th Floor
New York, New York 10018
Telephone 212.768.7676
www.mbbarch.com

Congregation Rodeph Shalom
7 West 83rd Street
New York, NY 10024

Scale
NTS

Date
09.14.2017
11.06.2017

LM 05

Existing
Floor Plans



01 EXISTING WINDOWS - PRIMARY ELEVATION WITH ART GLASS



01 PROPOSED WINDOWS - PRIMARY ELEVATION WITH CLEAR GLASS



F PROPOSED WINDOW FRAME FINISH - BLACK

MBB

Murphy Burnham & Buttrick Architects
48 West 37th Street, 14th Floor
New York, New York 10018
Telephone 212.768.7676
www.mbbarch.com

World Youth Alliance
228 East 71st Street
New York, NY 10021.

Scale
NTS

Date
09.14.2017
10.24.2017

LM 06

Primary Facade Windows
Existing & Proposed



BENT FRAME, INOPERABLE

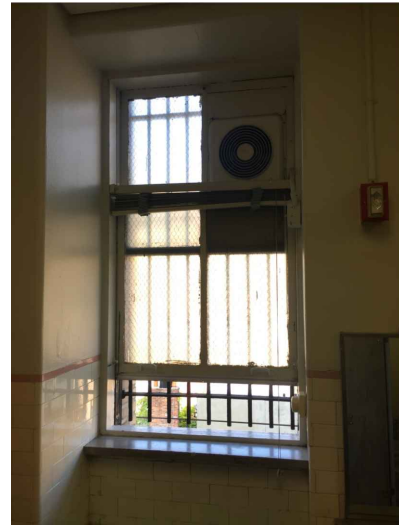

MODIFIED

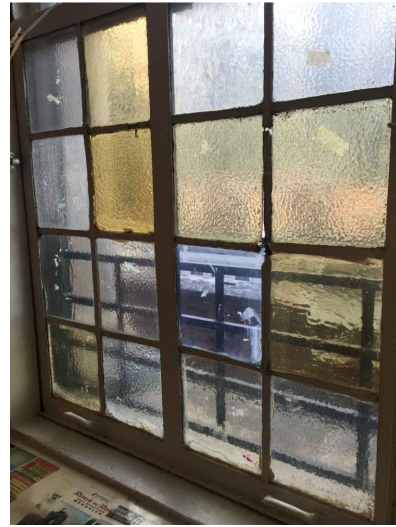

FAILING LEADING

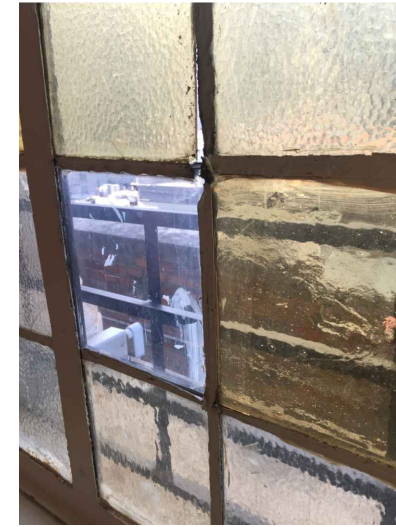

GAPS



BROKEN AND CRACKED GLASS



PENETRATIONS



MODIFIED WINDOWS



RUSTED FRAME

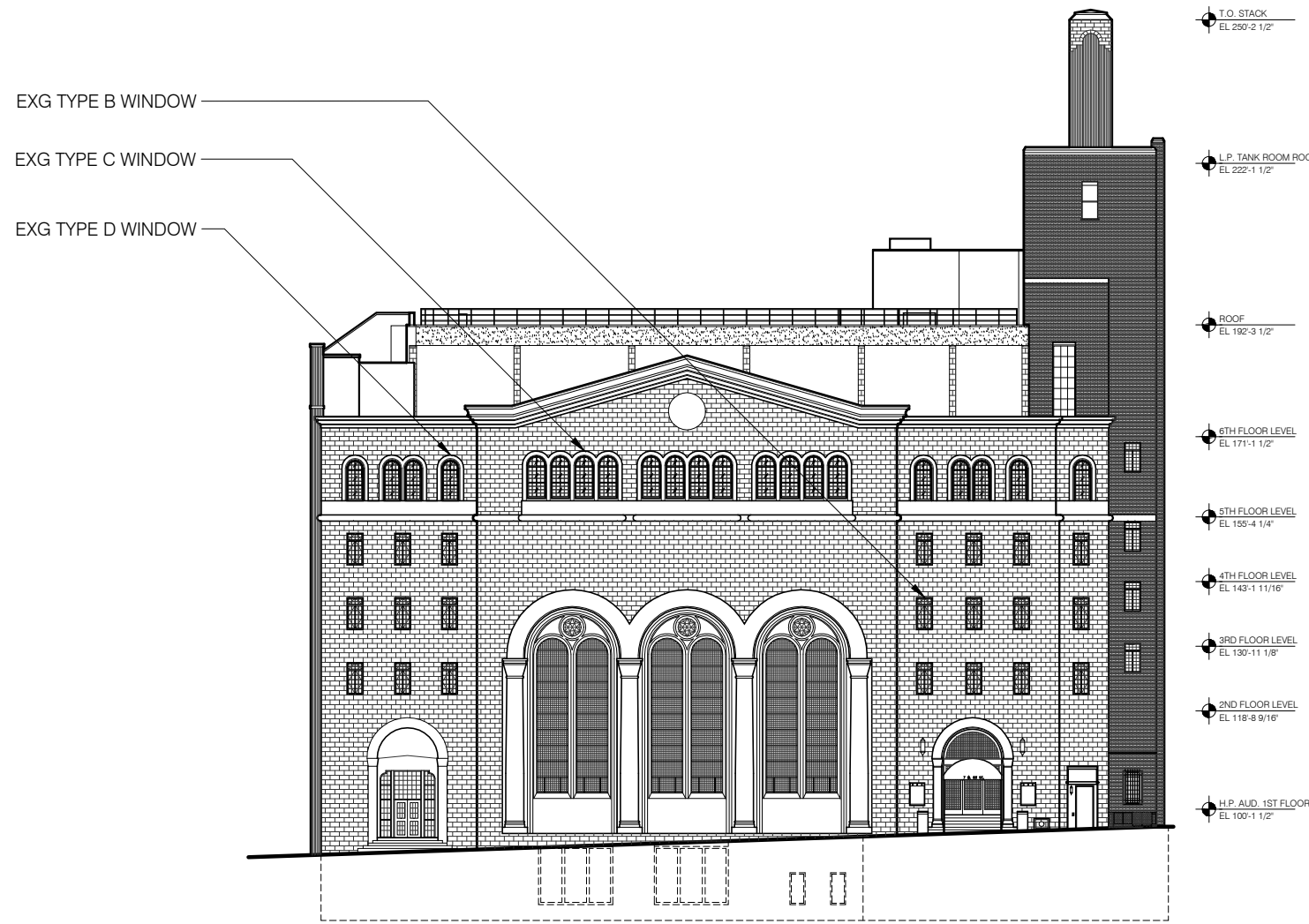

01 EXG SOUTH ELEVATION
SCALE: 1/32" = 1'-0"

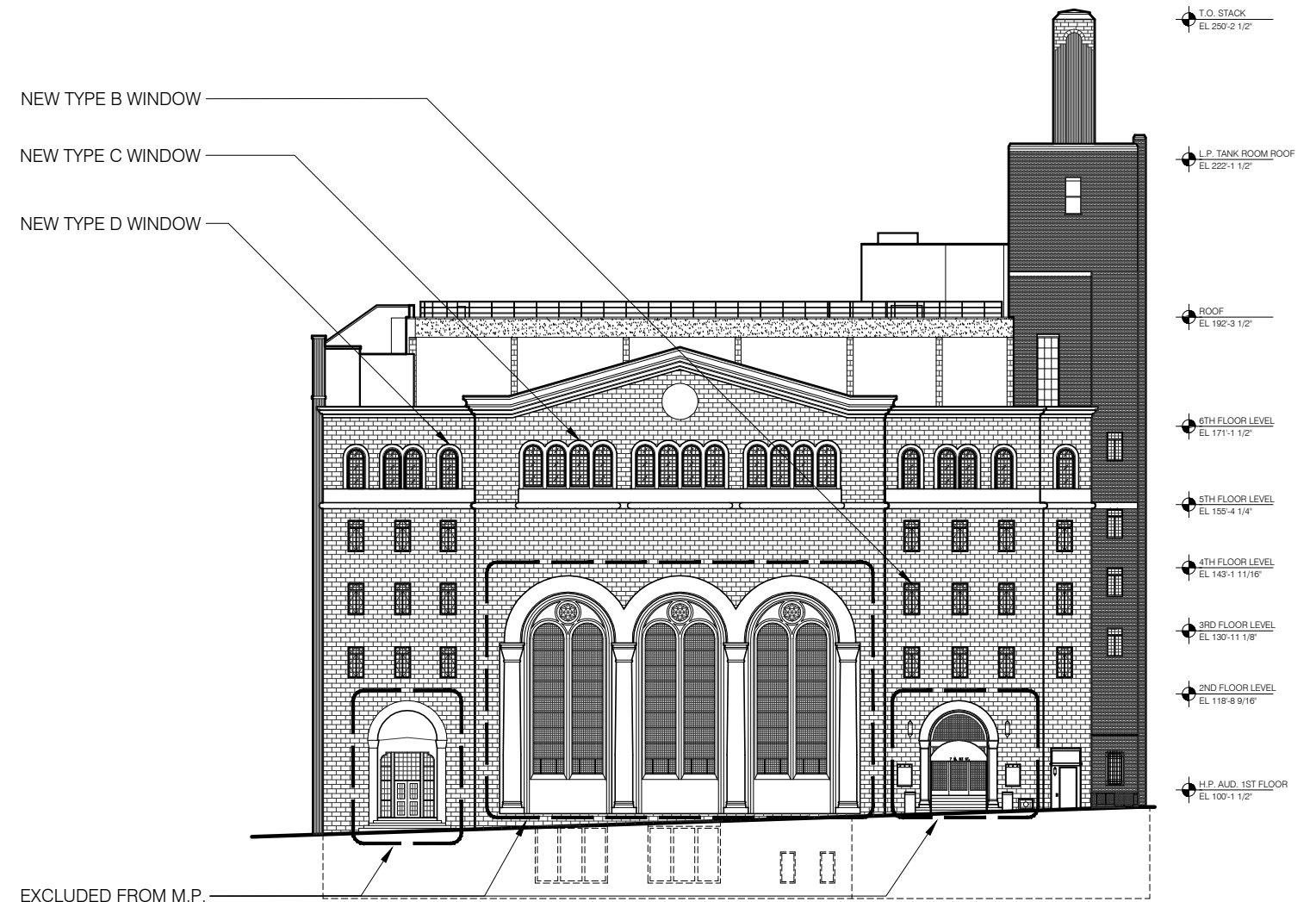

02 PROPOSED SOUTH ELEVATION
SCALE: 1/32" = 1'-0"

MBB

Murphy Burnham & Buttrick Architects
48 West 37th Street, 14th Floor
New York, New York 10018
Telephone 212.768.7676
www.mbbarch.com

Congregation Rodeph Shalom
7 West 83rd Street
New York, NY 10024

Scale
1/32" = 1'-0"

Date
09.14.2017
10.24.2017

LM 10

Existing & Proposed Elevations
South Elevation / Primary Facade

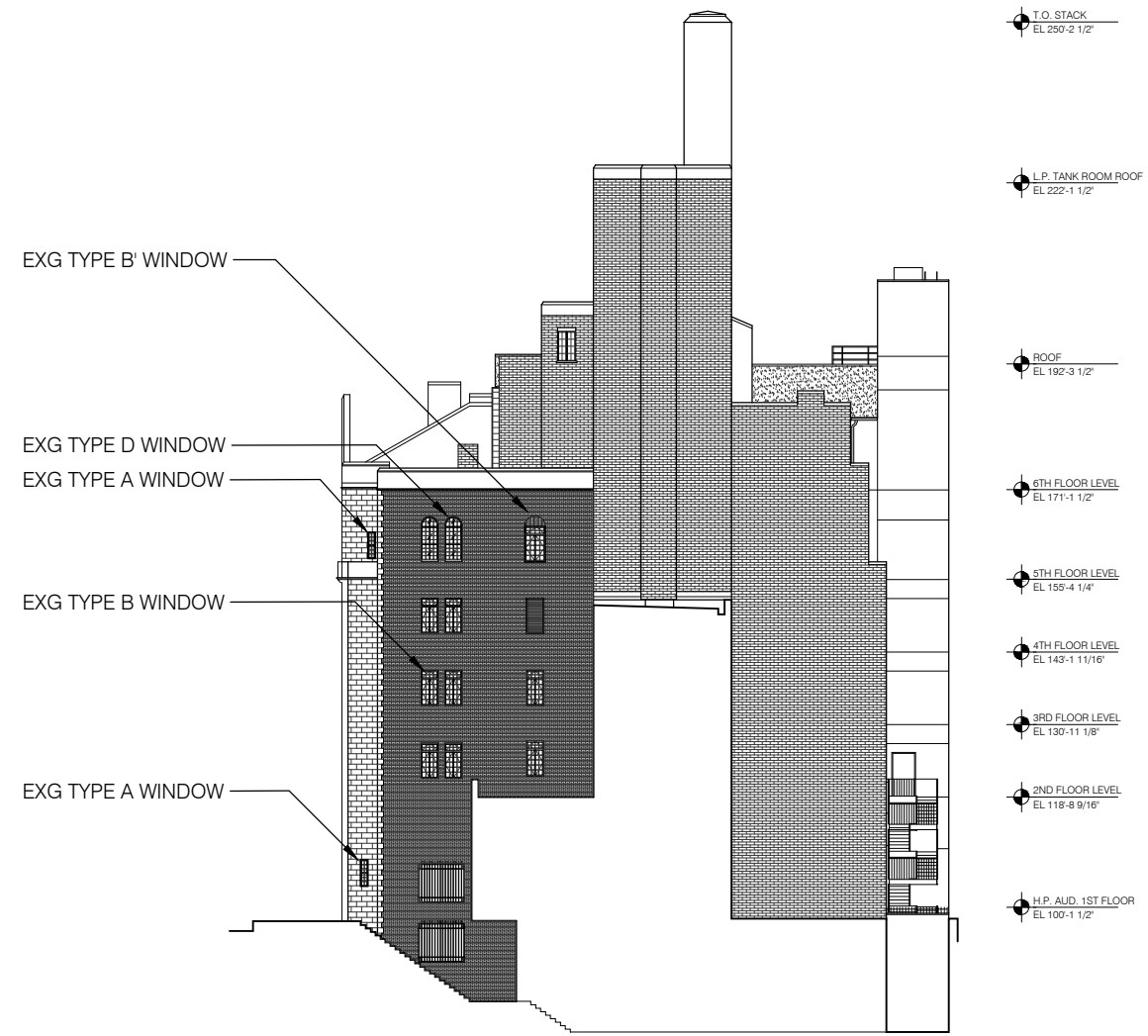

01 EXISTING EAST ELEVATION
SCALE: 1/32" = 1'-0"

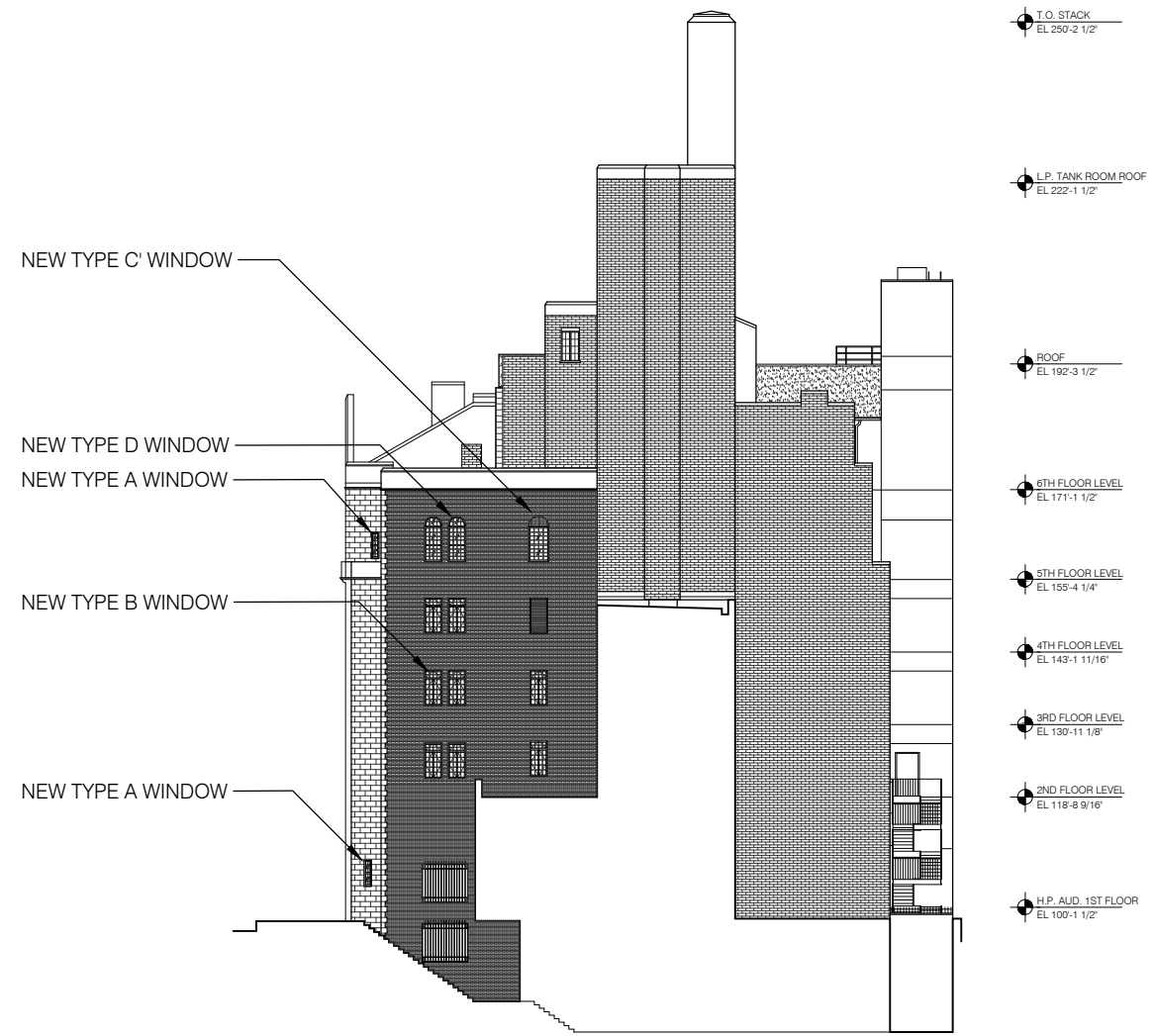

02 PROPOSED EAST ELEVATION
SCALE: 1/32" = 1'-0"

MBB

Murphy Burnham & Buttrick Architects
48 West 37th Street, 14th Floor
New York, New York 10018
Telephone 212.768.7676
www.mbbarch.com

Congregation Rodeph Sholom
7 West 83rd Street
New York, NY 10024

Scale
1/32" = 1'-0"

Date
09.14.2017
10.24.2017

LM 11

Existing & Proposed Elevations
East Elevation

T.O. STACK
 EL 250'-2 1/2"
 L.P. TANK ROOM ROOF
 EL 222'-1 1/2"
 ROOF
 EL 192'-3 1/2"
 6TH FLOOR LEVEL
 EL 171'-1 1/2"
 5TH FLOOR LEVEL
 EL 155'-4 1/4"
 4TH FLOOR LEVEL
 EL 143'-1 11/16"
 3RD FLOOR LEVEL
 EL 130'-11 1/8"
 2ND FLOOR LEVEL
 EL 118'-8 9/16"
 H.P. AUD. 1ST FLOOR
 EL 100'-1 1/2"

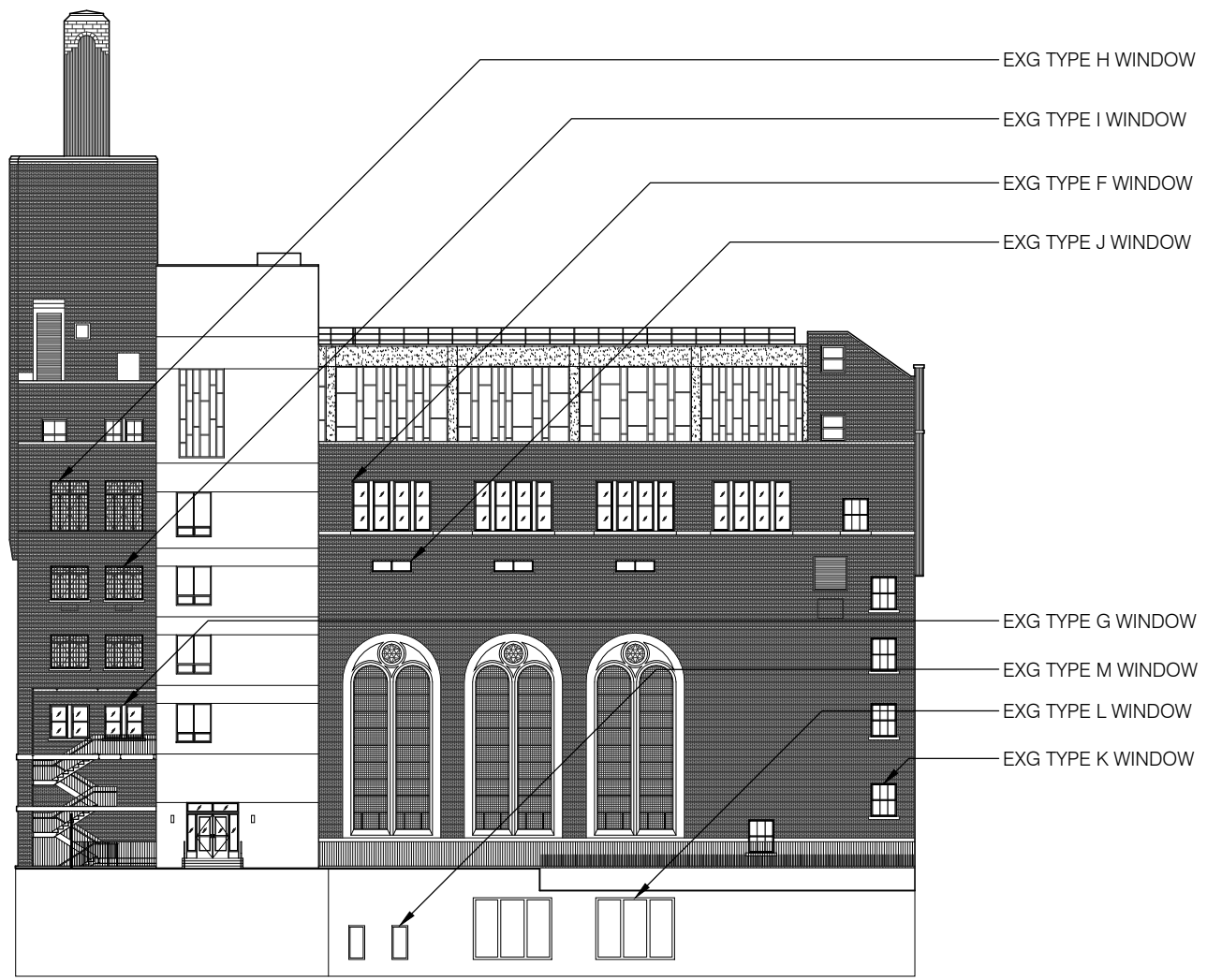

EXG TYPE H WINDOW
 EXG TYPE I WINDOW
 EXG TYPE F WINDOW
 EXG TYPE J WINDOW
 EXG TYPE G WINDOW
 EXG TYPE M WINDOW
 EXG TYPE L WINDOW
 EXG TYPE K WINDOW

01 EXG NORTH ELEVATION
 SCALE: 1/32" = 1'-0"

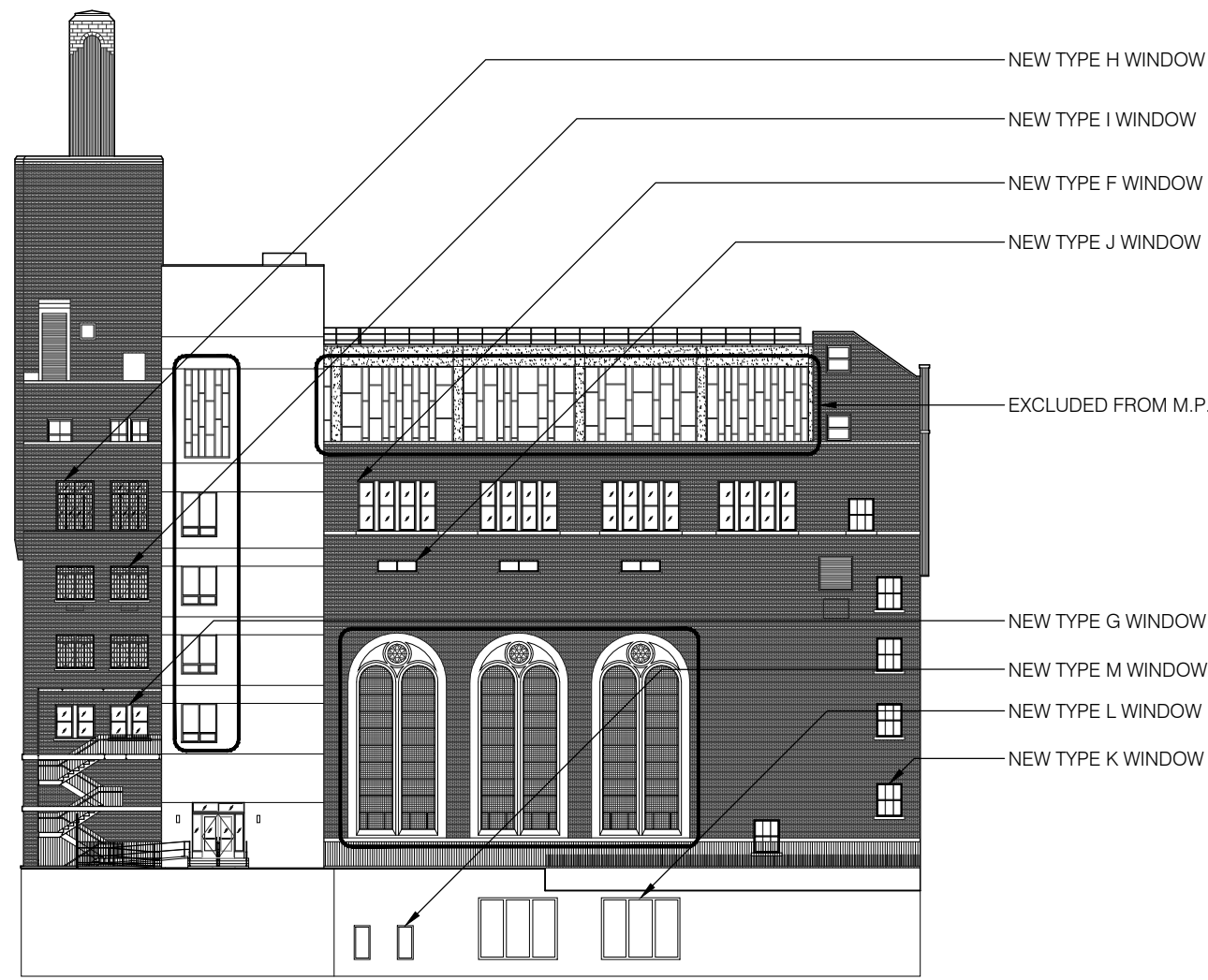

NEW TYPE H WINDOW
 NEW TYPE I WINDOW
 NEW TYPE F WINDOW
 NEW TYPE J WINDOW
 EXCLUDED FROM M.P.
 NEW TYPE G WINDOW
 NEW TYPE M WINDOW
 NEW TYPE L WINDOW
 NEW TYPE K WINDOW

02 PROPOSED NORTH ELEVATION
 SCALE: 1/32" = 1'-0"

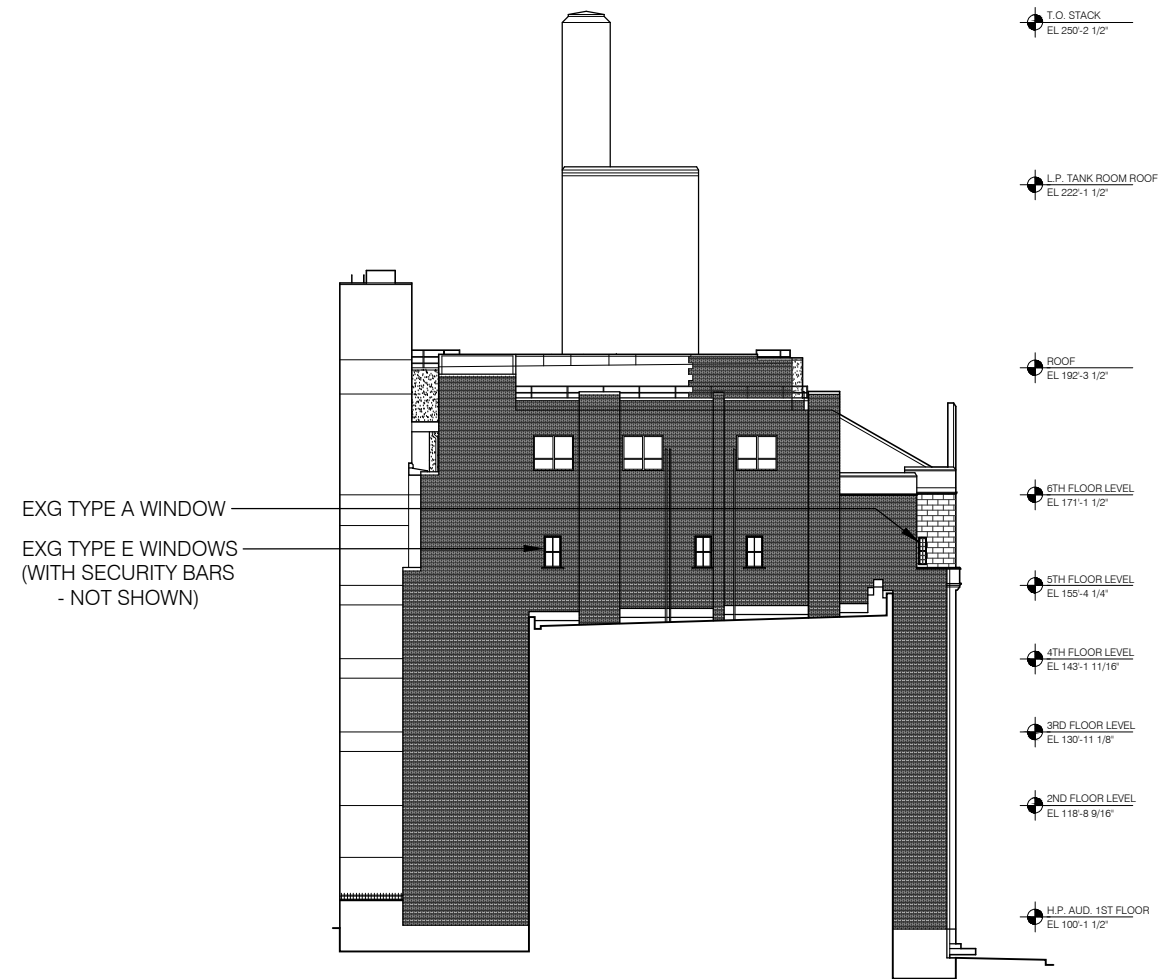

01 EXISTING WEST ELEVATION
SCALE: 1/32" = 1'-0"

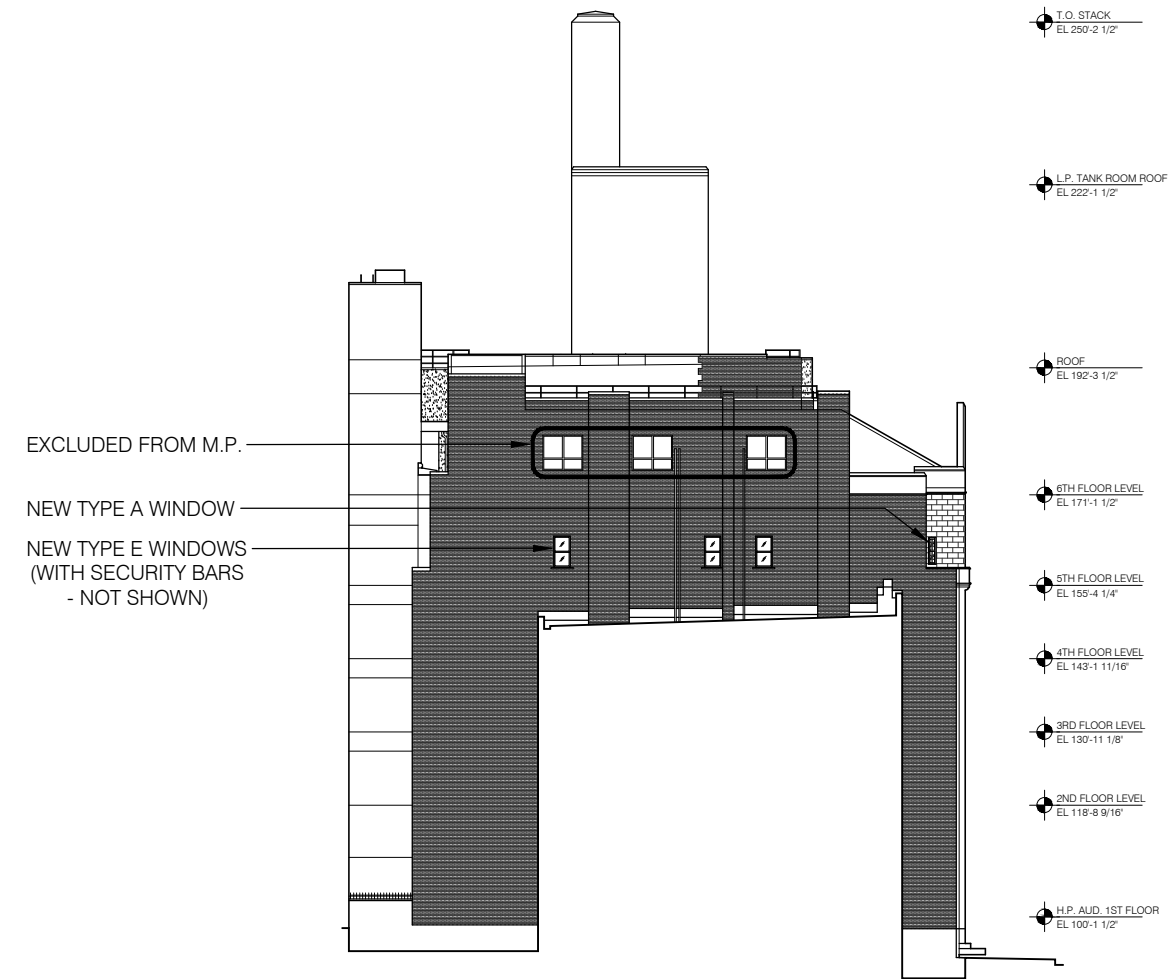

02 PROPOSED WEST ELEVATION
SCALE: 1/32" = 1'-0"

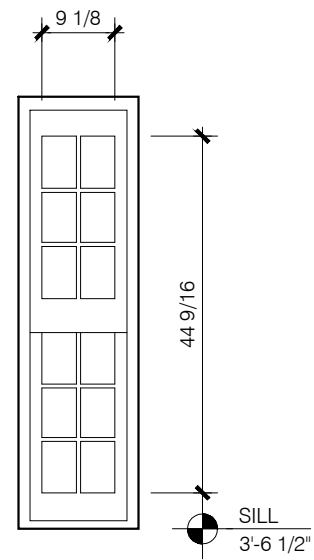
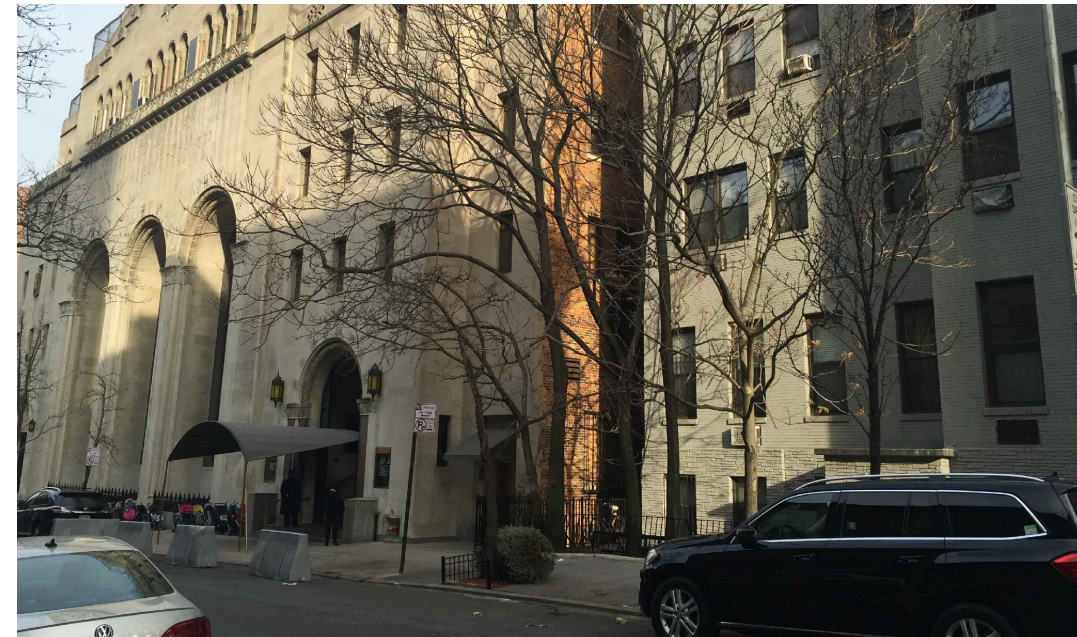

A EXG STEEL, ART GLASS
DOUBLE HUNG
GLASS AREA: 407 in²

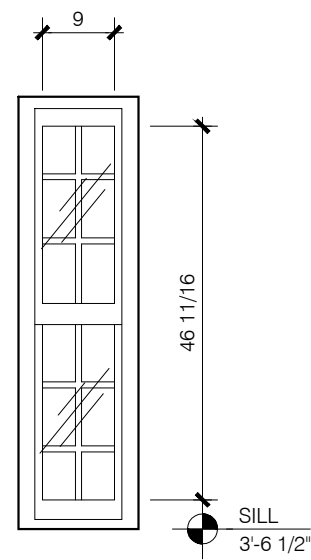

A NEW ALUM., CLR GLASS
DOUBLE HUNG
GLASS AREA: 420 in²
PERCENT DIFFERENCE: +3%
SIDE ELEVATION
5TH FLOOR

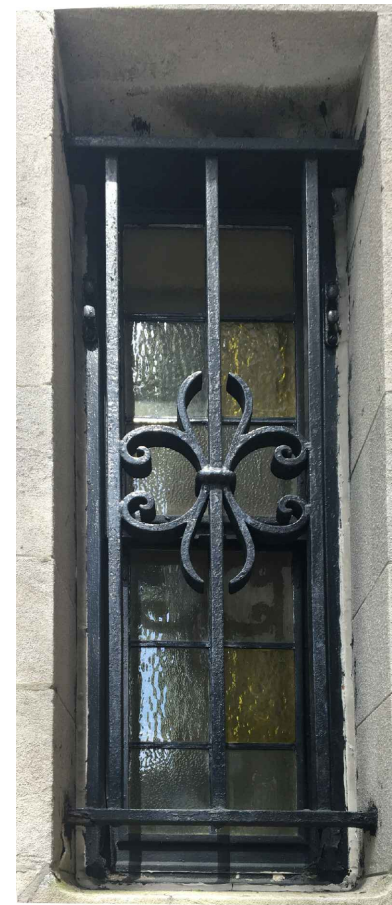

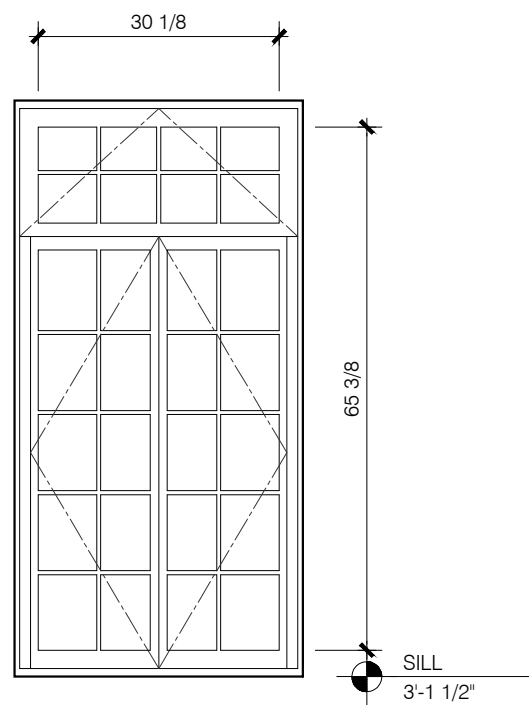

B EXG STEEL, ART GLASS
TRANSOM OVER CASEMENT
GLASS AREA: 1969 in²

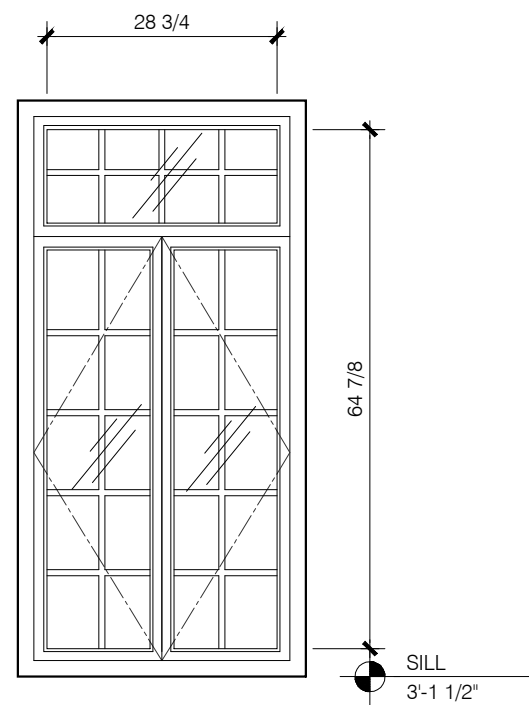

B NEW ALUM., CLEAR GLASS
TRANSOM OVER CASEMENT
GLASS AREA: 1865 in²
PERCENT DIFFERENCE: +5%
FRONT AND SIDE ELEVATION

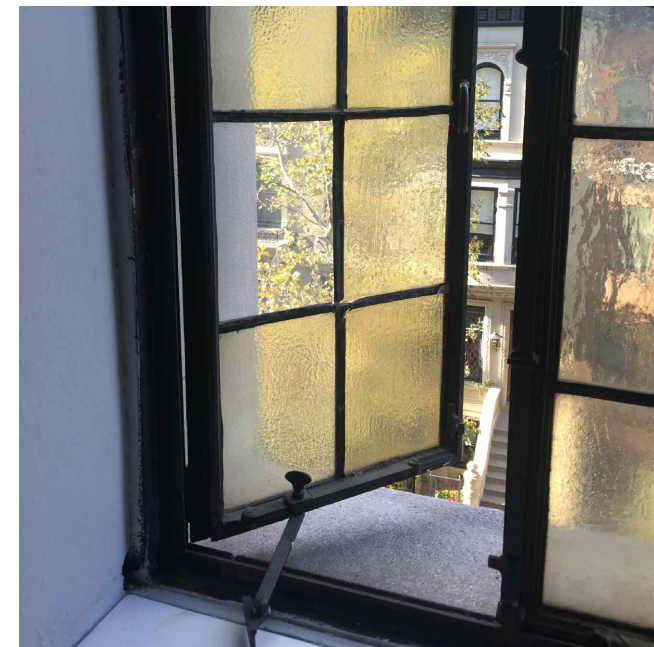

MBB

Murphy Burnham & Buttrick Architects
48 West 37th Street, 14th Floor
New York, New York 10018
Telephone 212.768.7676
www.mbbarch.com

Congregation Rodeph Shalom
7 West 83rd Street
New York, NY 10024

Scale
N.T.S.

Date
09.14.2017
10.24.2017
10.30.2017
11.06.2017

LM 21

Existing & Proposed
Window Type B
Street Facing

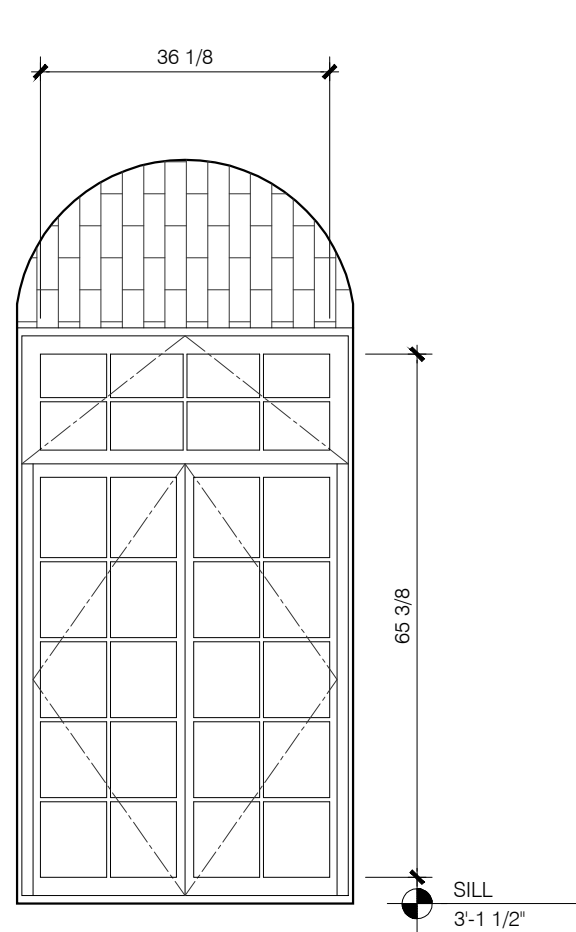

B' EXG STEEL, ART GLASS
TRANSOM OVER CASEMENT
GLASS AREA: 2361 in²

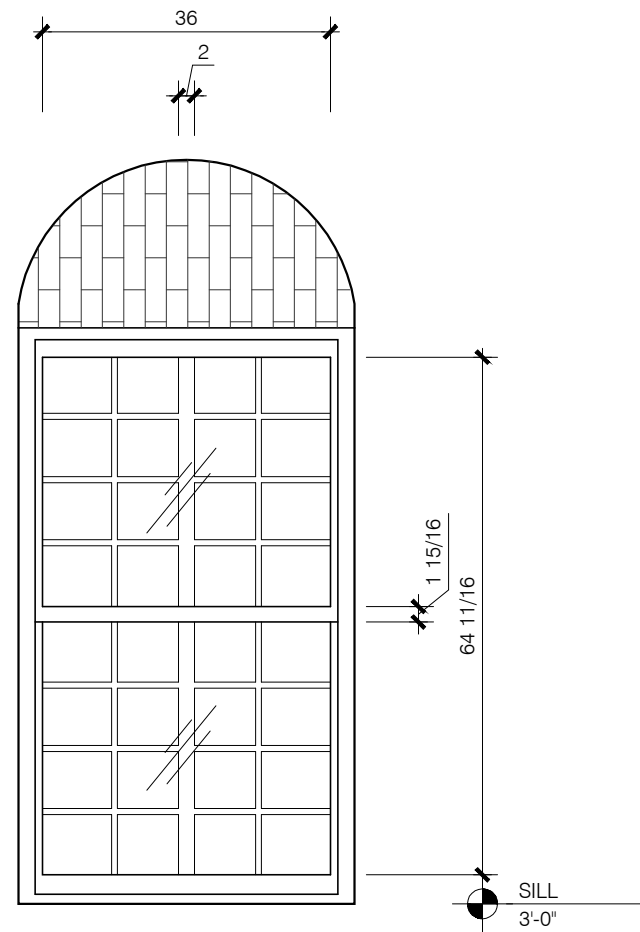

C' NEW ALUM., CLEAR GLASS
DOUBLE HUNG
GLASS AREA: 2328 in²
PERCENT DIFFERENCE: -1%
FRONT AND SIDE ELEVATION

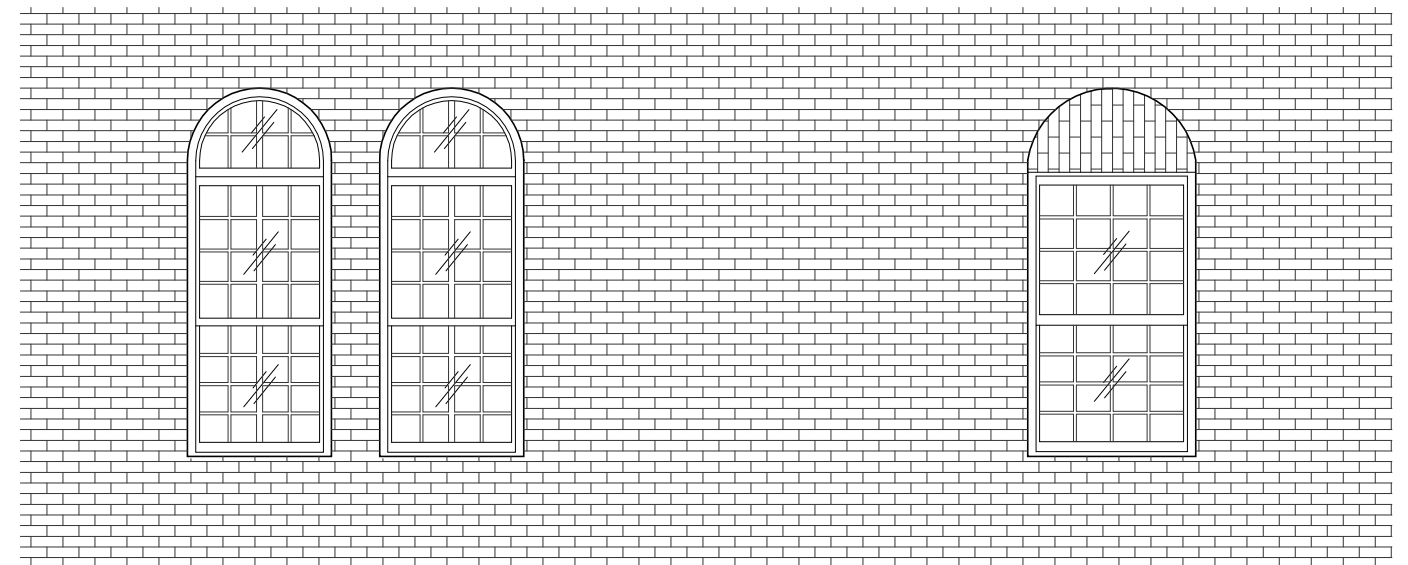
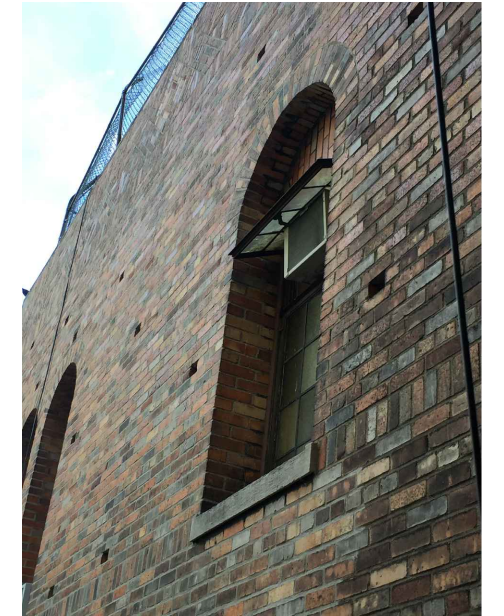
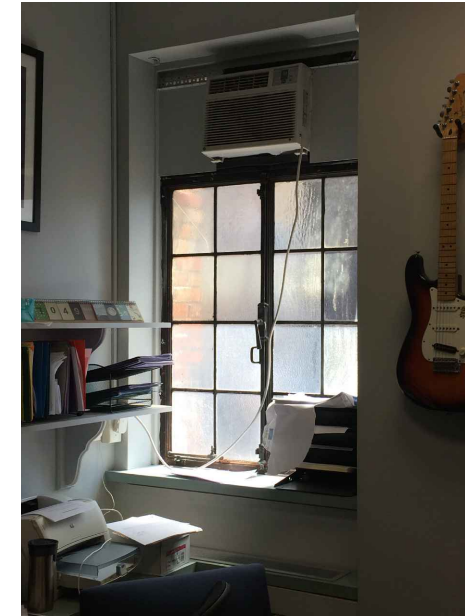

EXTERIOR ELEVATION
EXG STEEL, ART GLASS
TRANSOM OVER CASEMENT

MBB

Murphy Burnham & Buttrick Architects
48 West 37th Street, 14th Floor
New York, New York 10018
Telephone 212.768.7676
www.mbbarch.com

Congregation Rodeph Shalom
7 West 83rd Street
New York, NY 10024

Scale
N.T.S.

Date
09.14.2017
10.24.2017
10.30.2017
11.06.2017

LM 22

Existing & Proposed
Window Type B'
Street Facing

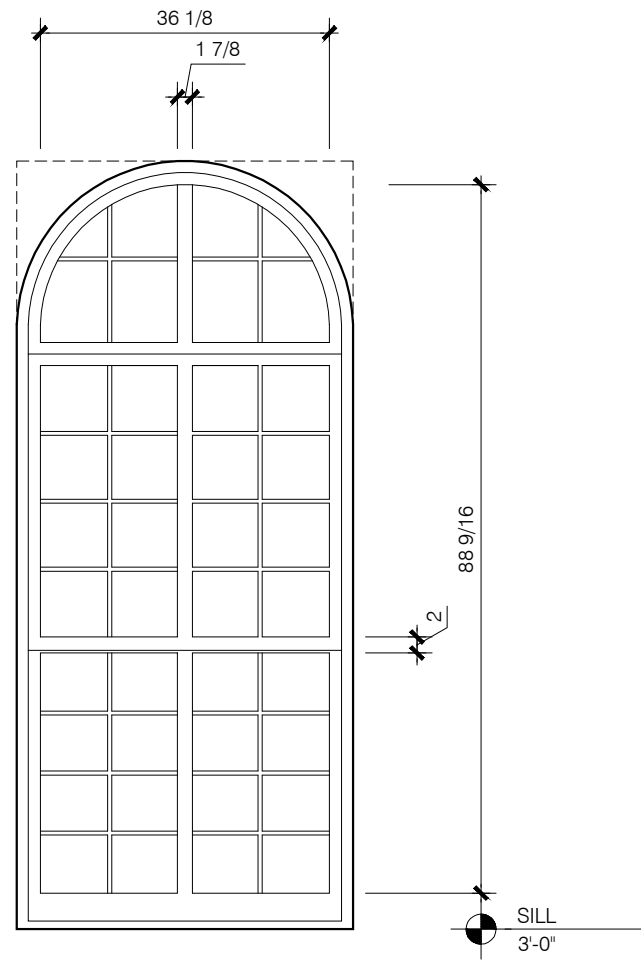

C EXG STEEL, ART GLASS
TRANSOM OVER DOUBLE HUNG
GLASS AREA: 3060 in²

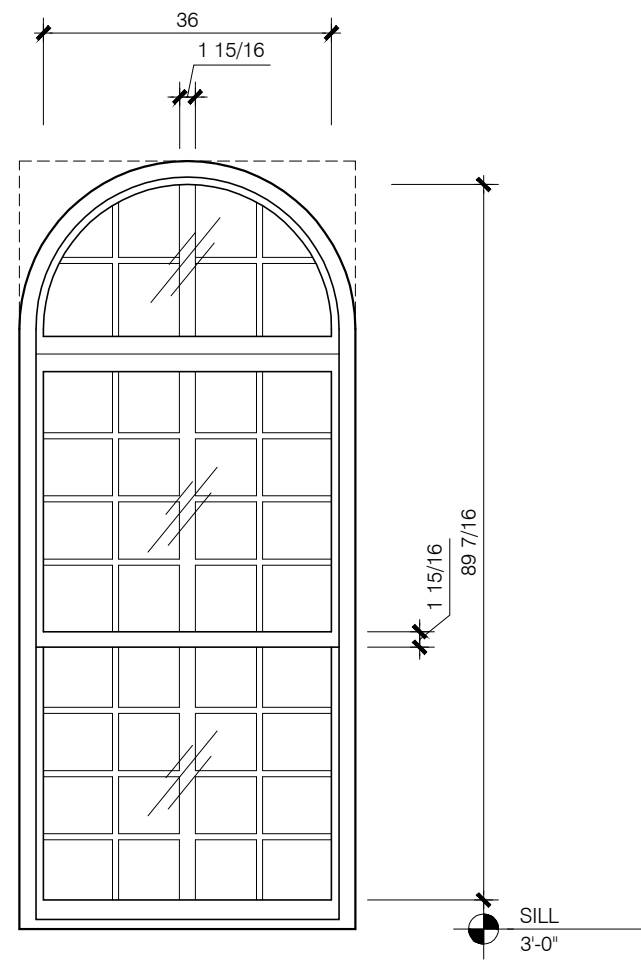

C NEW ALUM., CLEAR GLASS
TRANSOM OVER DOUBLE HUNG
GLASS AREA: 3081 in²
PERCENT DIFFERENCE: +1%
FRONT ELEVATION
5TH FLOOR



MBB

Murphy Burnham & Buttrick Architects
48 West 37th Street, 14th Floor
New York, New York 10018
Telephone 212.768.7676
www.mbbarch.com

Congregation Rodeph Shalom
7 West 83rd Street
New York, NY 10024

Scale
N.T.S.

Date
09.14.2017
10.24.2017
10.30.2017
11.06.2017

LM 23

Existing & Proposed
Window Type C
Street Facing

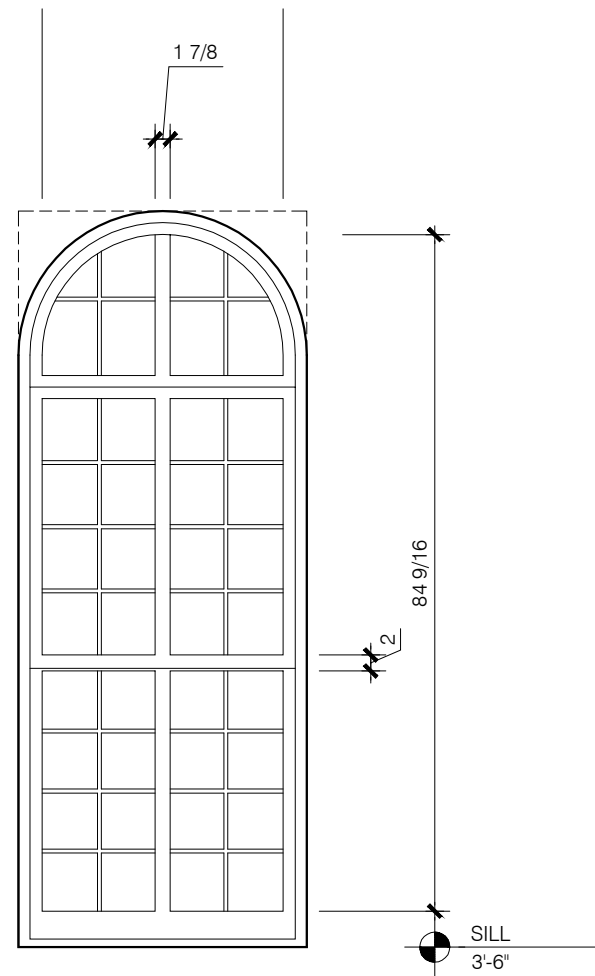

D EXG STEEL, ART GLASS
TRANSOM OVER DOUBLE HUNG
GLASS AREA: 2450 in²

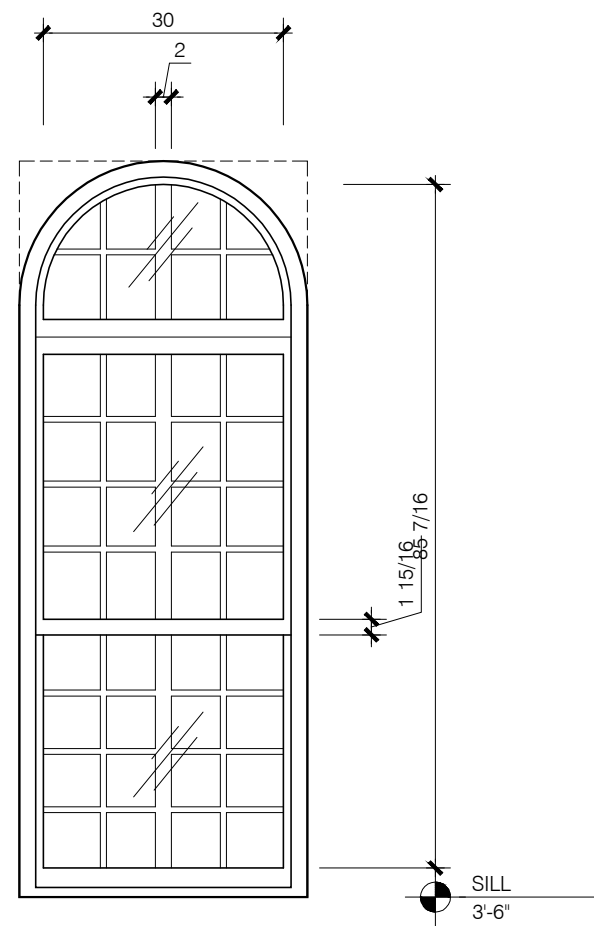

D NEW ALUM., CLEAR GLASS
TRANSOM OVER DOUBLE HUNG
GLASS AREA: 2467 in²
PERCENT DIFFERENCE: +1%
FRONT AND SIDE ELEVATION
5TH FLOOR

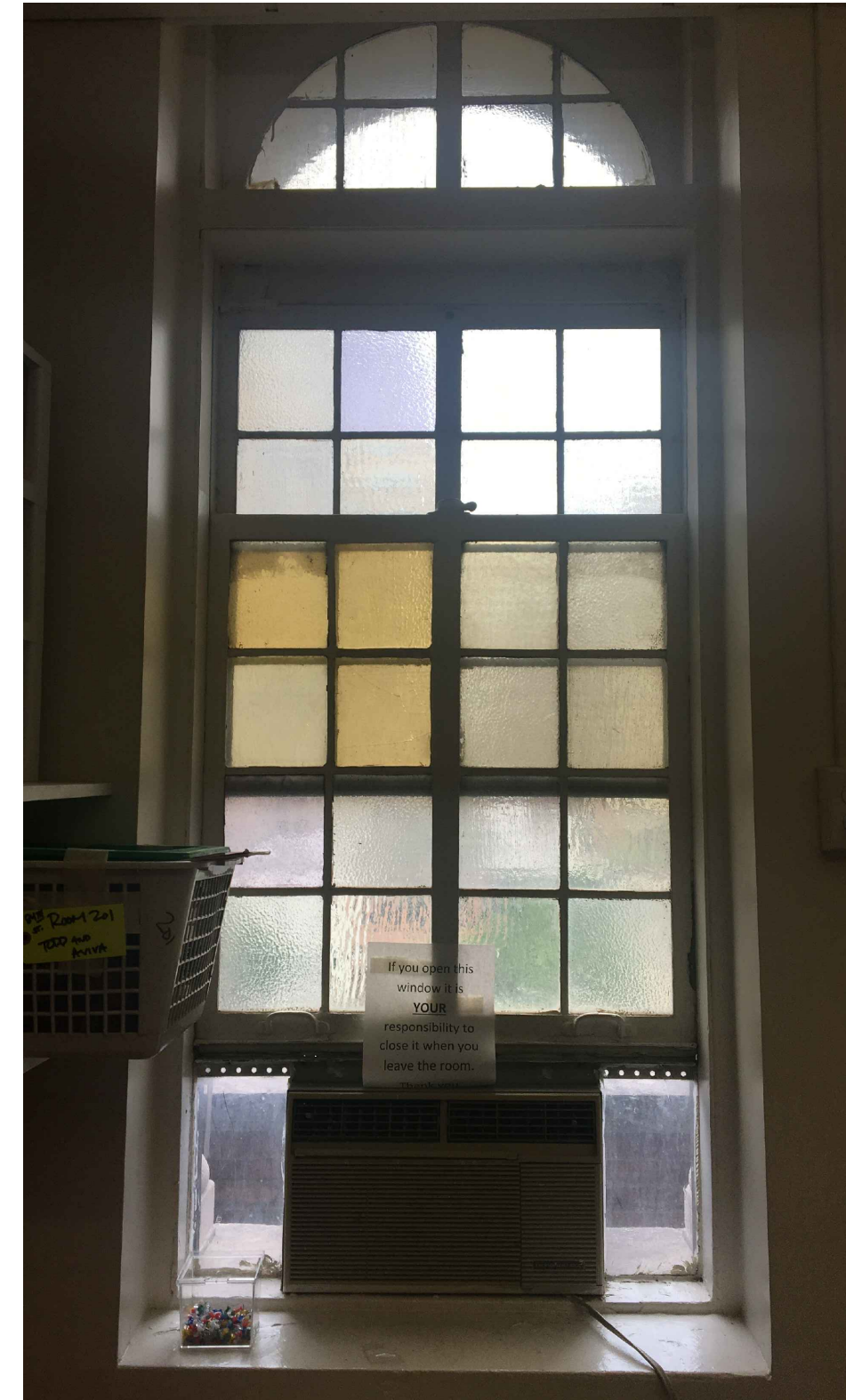

MBB

Murphy Burnham & Buttrick Architects
48 West 37th Street, 14th Floor
New York, New York 10018
Telephone 212.768.7676
www.mbbarch.com

Congregation Rodeph Shalom
7 West 83rd Street
New York, NY 10024

Scale
N.T.S.

Date
09.14.2017
10.24.2017
10.30.2017
11.06.2017

LM 24

Existing & Proposed
Window Type D
Street Facing

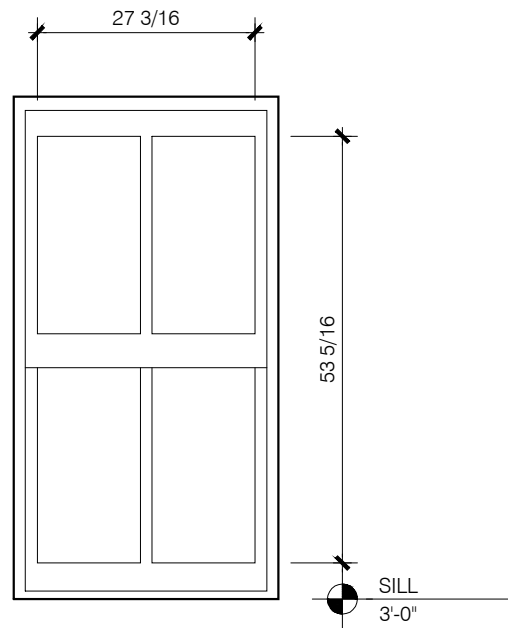

E EXG STEEL, WIRE GLASS
DOUBLE HUNG
GLASS AREA: 1450 in²

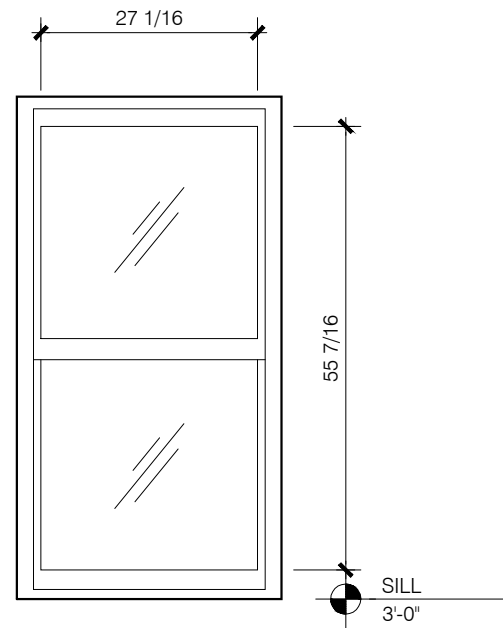

E NEW ALUM., CLEAR GLASS
DOUBLE HUNG
GLASS AREA: 1500 in²
PERCENT DIFFERENCE: +3%
SIDE ELEVATION
5TH FLOOR

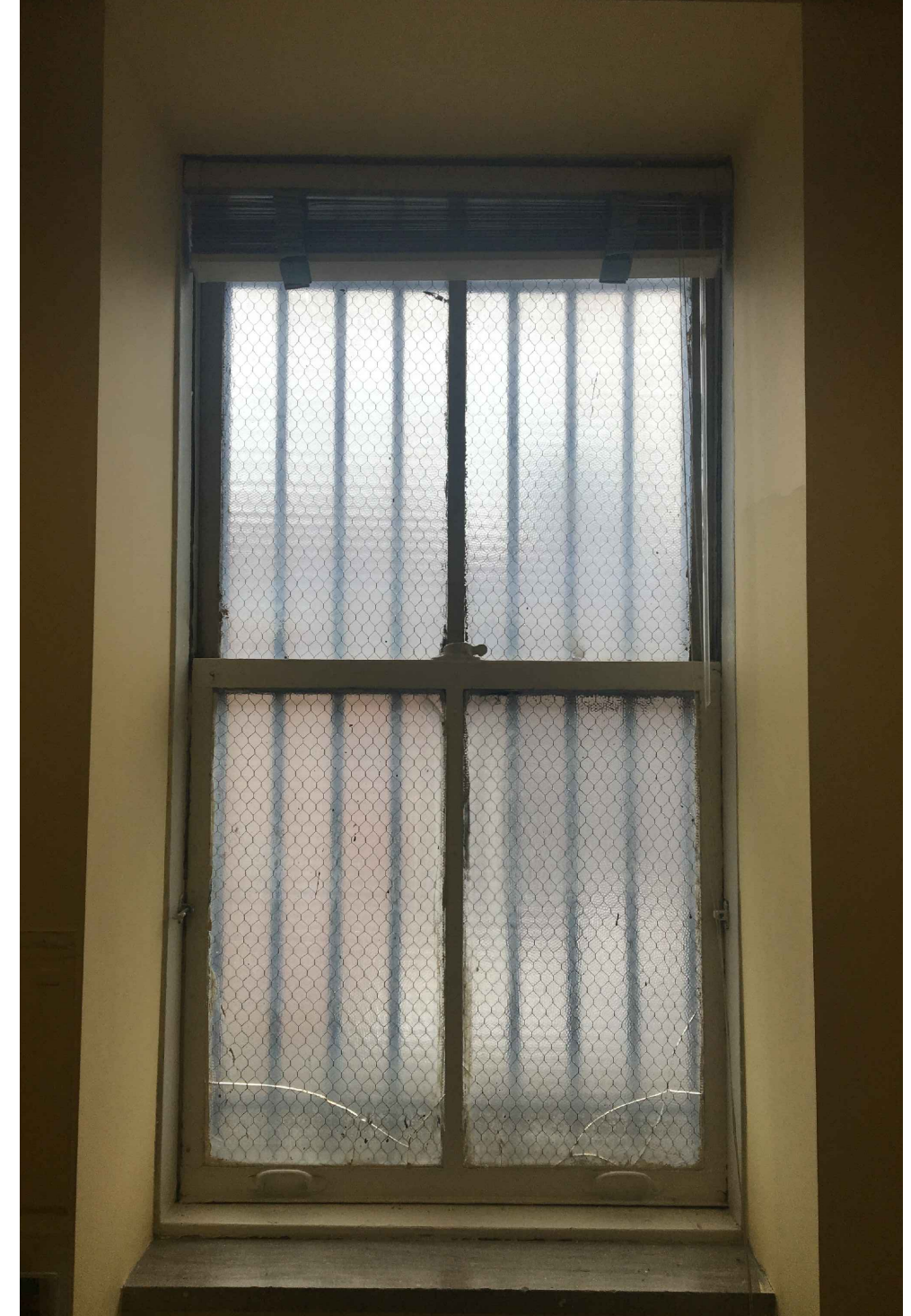

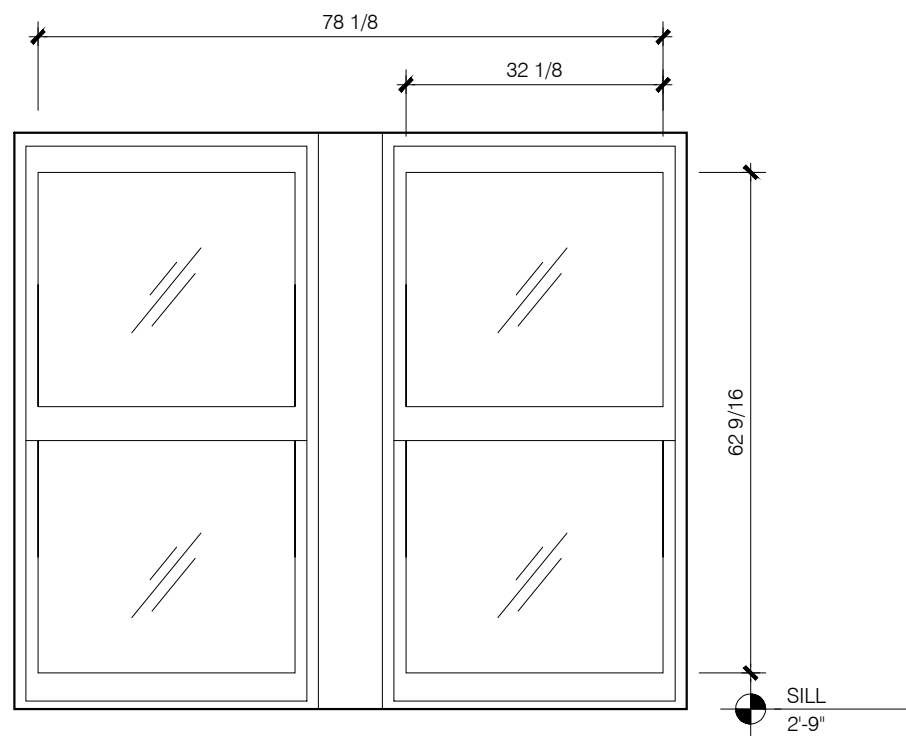

G EXG STEEL, CLEAR GLASS
DOUBLE HUNG
GLASS AREA: 2010 in²

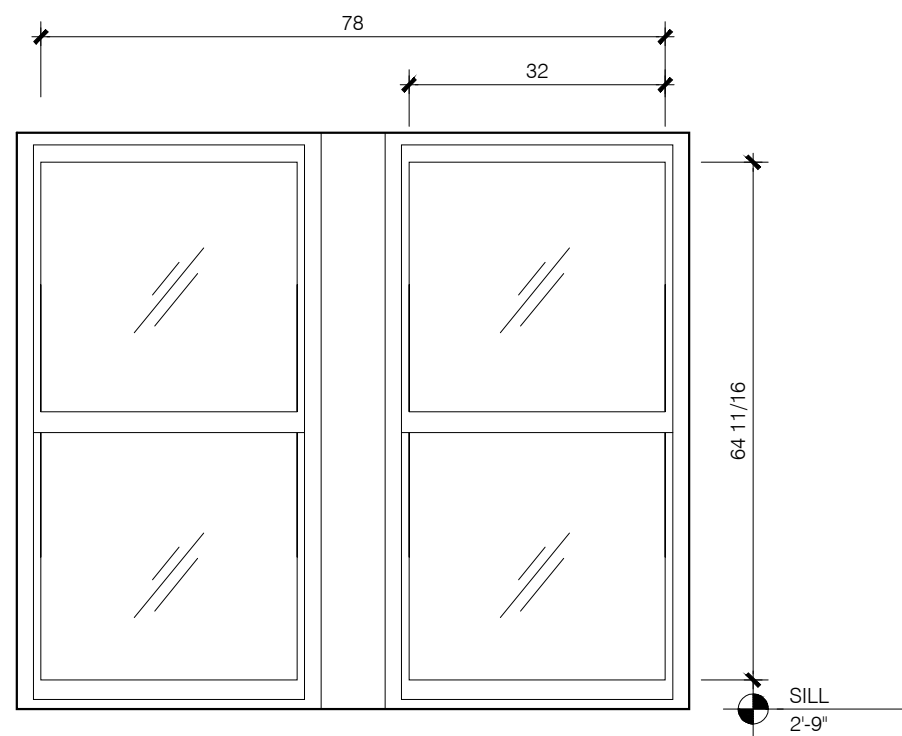

G NEW ALUMINIUM, CLEAR GLASS
DOUBLE HUNG
GLASS AREA: 2070 in²
PERCENT DIFFERENCE: +3%
REAR ELEVATION
NOT VISIBLE FROM STREET



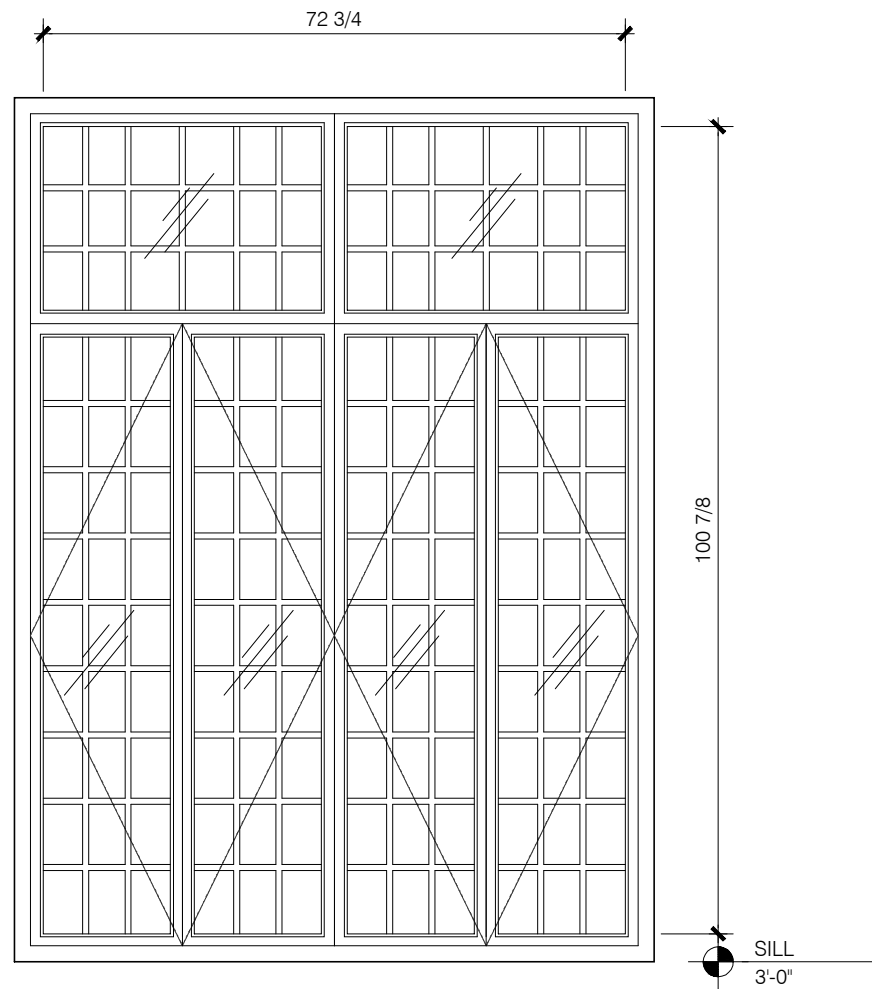
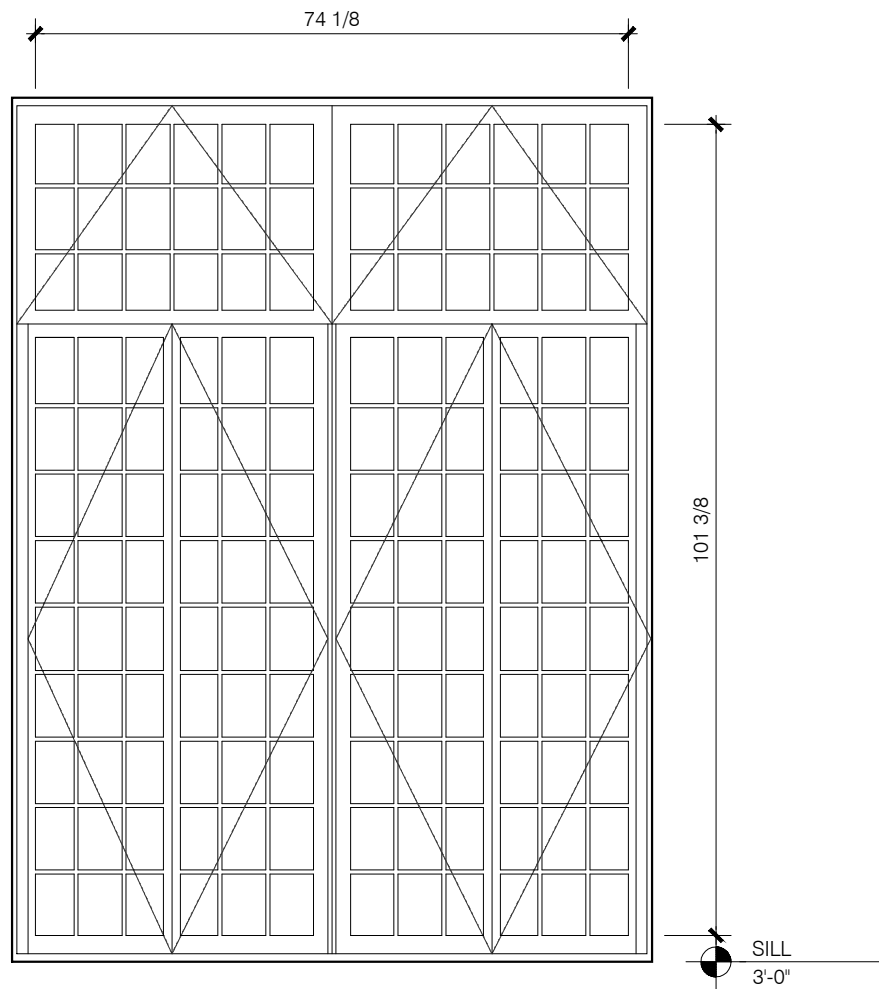

H EXG STEEL, CLEAR GLASS
TRANSOM OVER CASEMENT
GLASS AREA: 7514 in²

H NEW ALUM., CLEAR GLASS
DOUBLE HUNG
GLASS AREA: 7451 in²
PERCENT DIFFERENCE: -1%
REAR ELEVATION
NOT VISIBLE FROM STREET

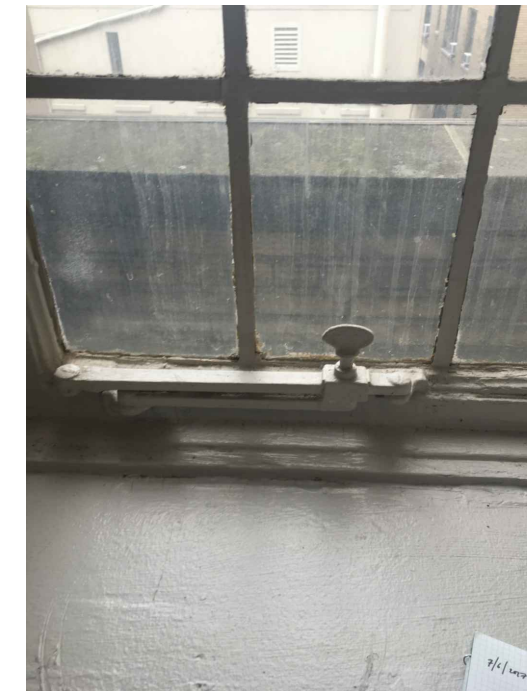
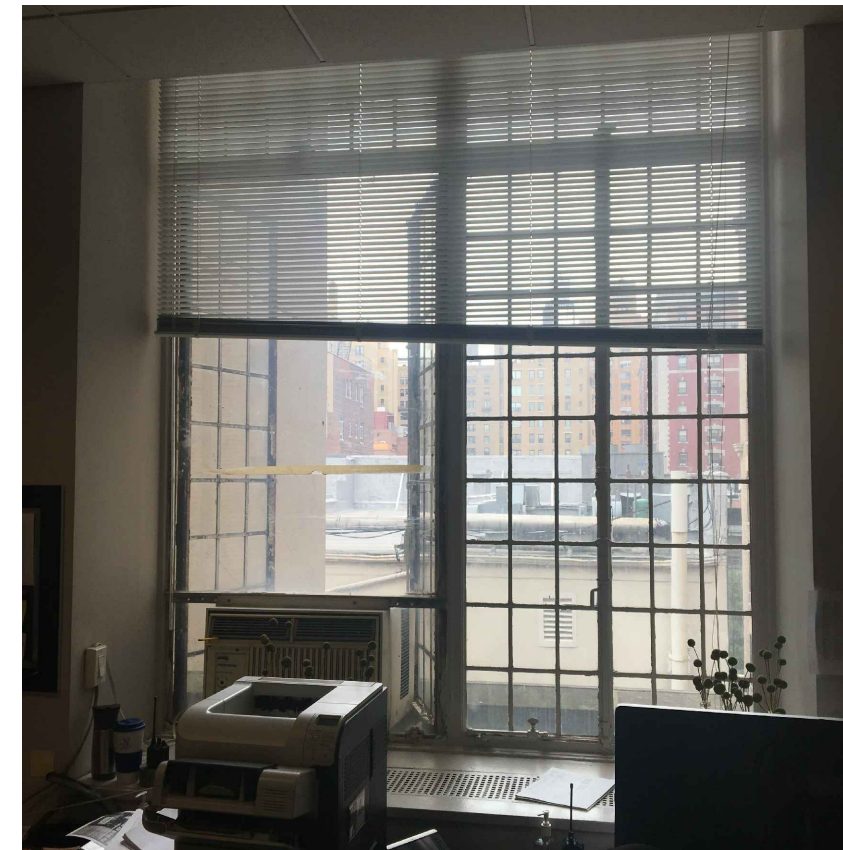

MBB

Murphy Burnham & Buttrick Architects
48 West 37th Street, 14th Floor
New York, New York 10018
Telephone 212.768.7676
www.mbbarch.com

Congregation Rodeph Shalom
7 West 83rd Street
New York, NY 10024

Scale
N.T.S.

Date
09.14.2017
10.24.2017
11.06.2017

LM 27

Existing & Proposed
Window Type H
Rear - Not Visible

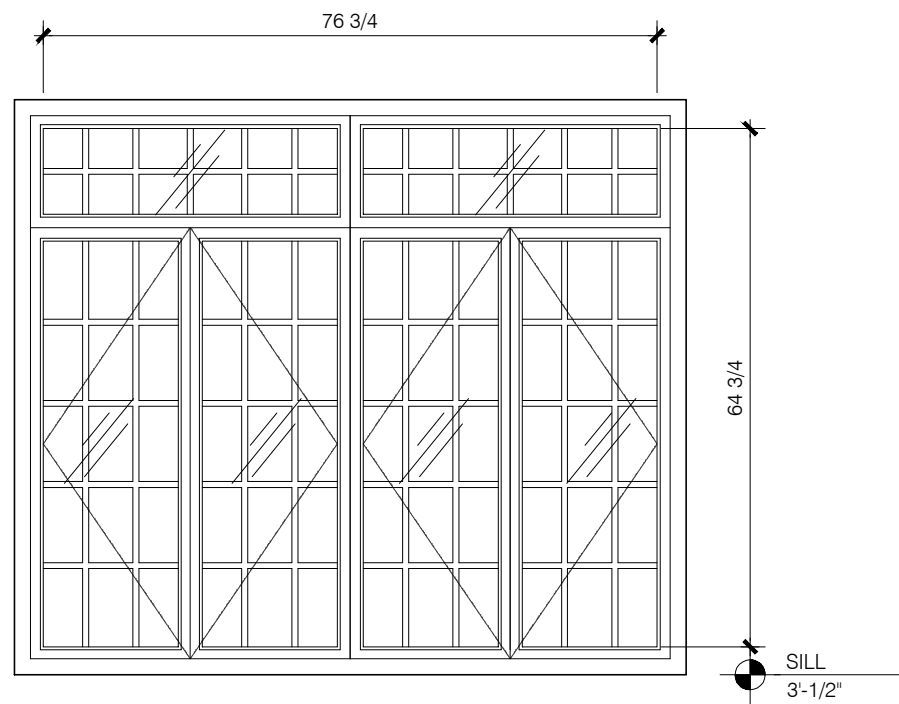
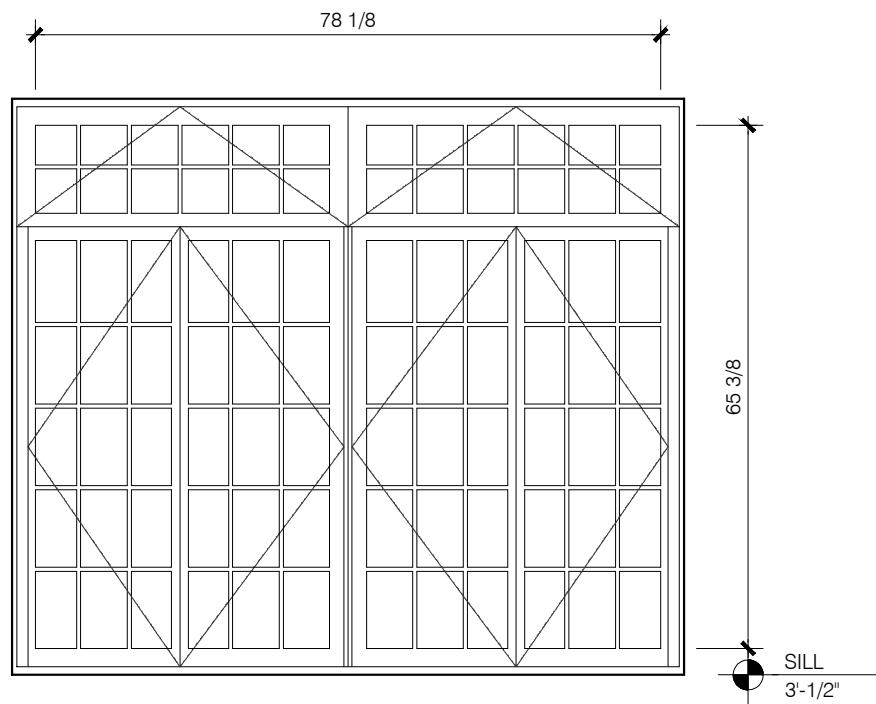

EXG STEEL, CLEAR GLASS
TRANSOM OVER CASEMENT
GLASS AREA: 5107 in²

NEW ALUM., CLEAR GLASS
DOUBLE HUNG
GLASS AREA: 4775 in²
PERCENT DIFFERENCE: -7%
REAR ELEVATION
NOT VISIBLE FROM STREET

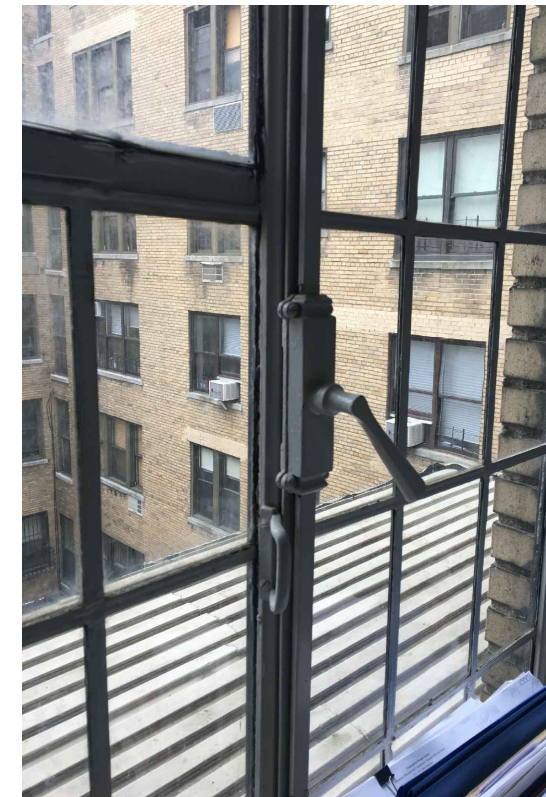
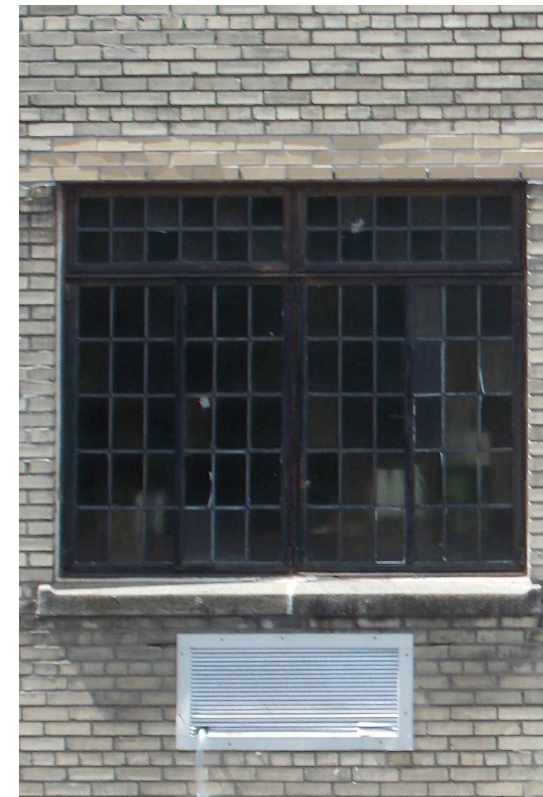
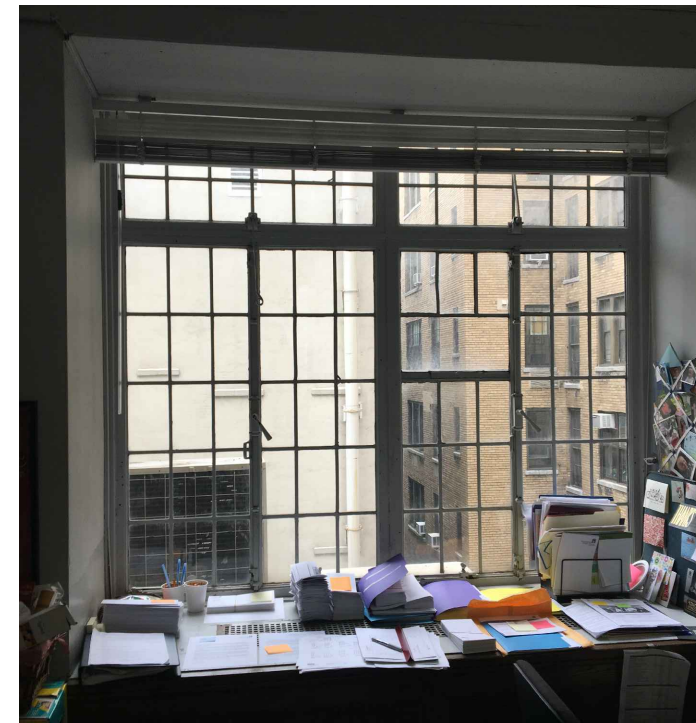

MBB

Murphy Burnham & Buttrick Architects
48 West 37th Street, 14th Floor
New York, New York 10018
Telephone 212.768.7676
www.mbbarch.com

Congregation Rodeph Sholom
7 West 83rd Street
New York, NY 10024

Scale
N.T.S.

Date
09.14.2017
10.24.2017
11.06.2017

LM 28

Existing & Proposed
Window Type I
Rear - Not Visible

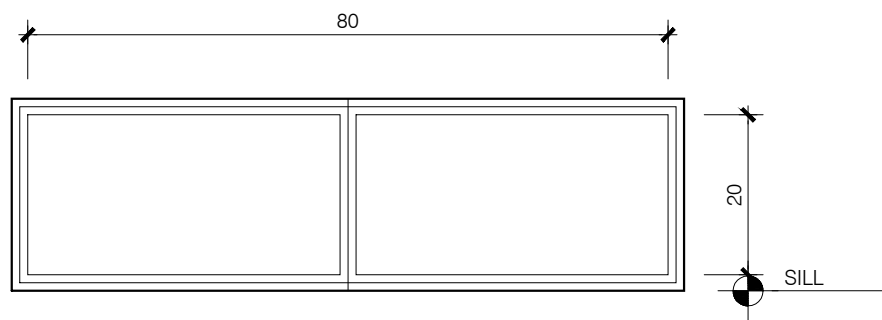
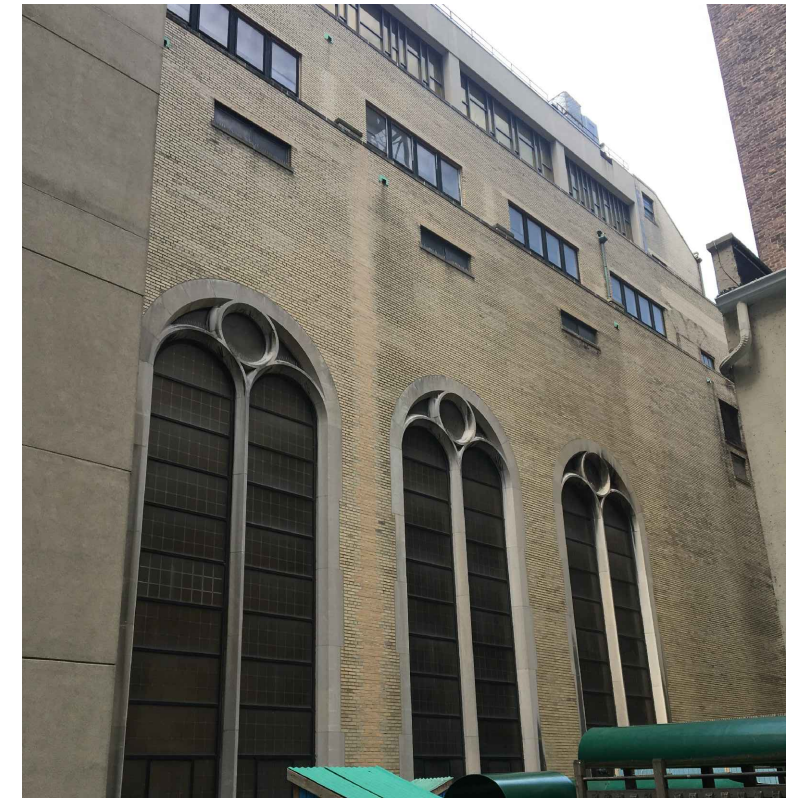

J EXG STEEL, CLEAR GLASS
FIXED
GLASS AREA: 1600 in²

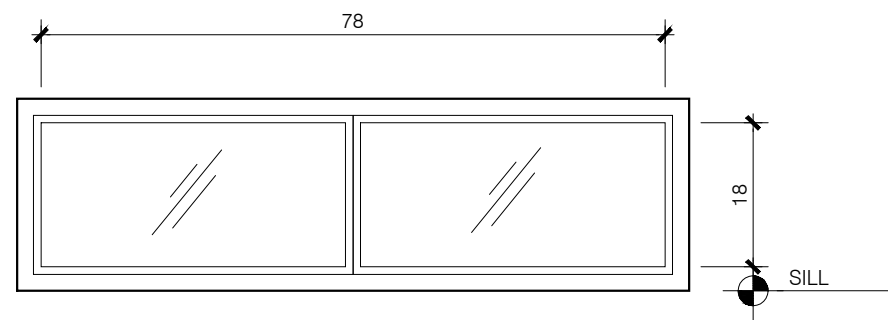

J NEW ALUM., CLEAR GLASS
FIXED
GLASS AREA: 1404 in²
PERCENT DIFFERENCE: -12%
REAR ELEVATION
NOT VISIBLE FROM STREET

MBB

Murphy Burnham & Buttrick Architects
48 West 37th Street, 14th Floor
New York, New York 10018
Telephone 212.768.7676
www.mbbarch.com

Congregation Rodeph Shalom
7 West 83rd Street
New York, NY 10024

Scale
N.T.S.

Date
09.14.2017
10.24.2017
11.06.2017

LM 29

Existing & Proposed
Window Type J
Rear - Not Visible

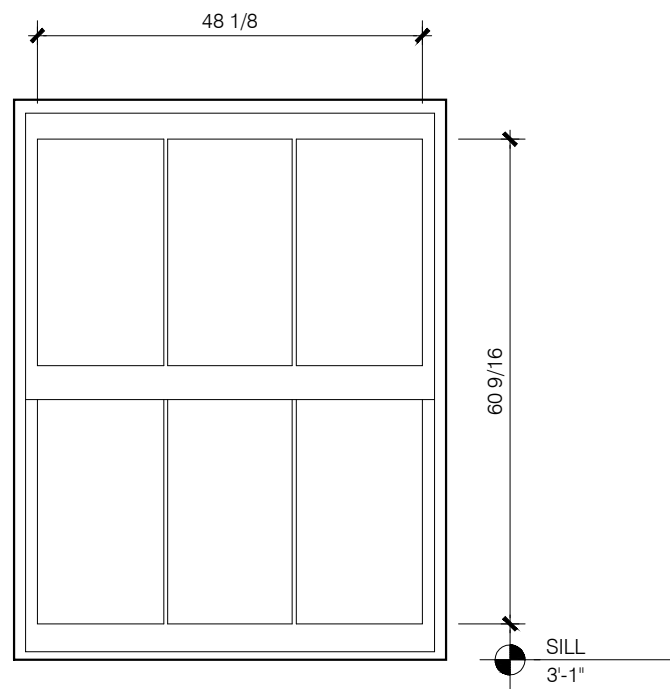

K EXG STEEL
DOUBLE HUNG
GLASS AREA: 2915 in²

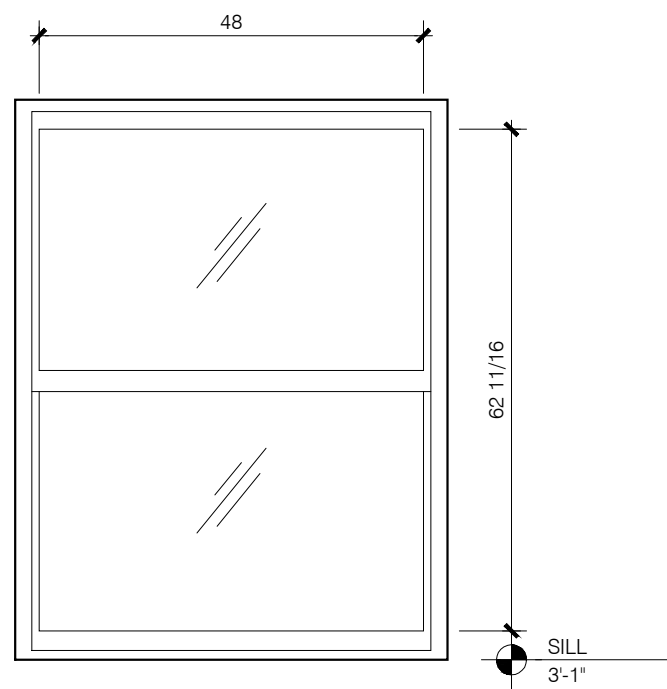

K NEW ALUMINUM
DOUBLE HUNG
GLASS AREA: 3009 in²
PERCENT DIFFERENCE: +3%
REAR ELEVATION
NOT VISIBLE FROM STREET

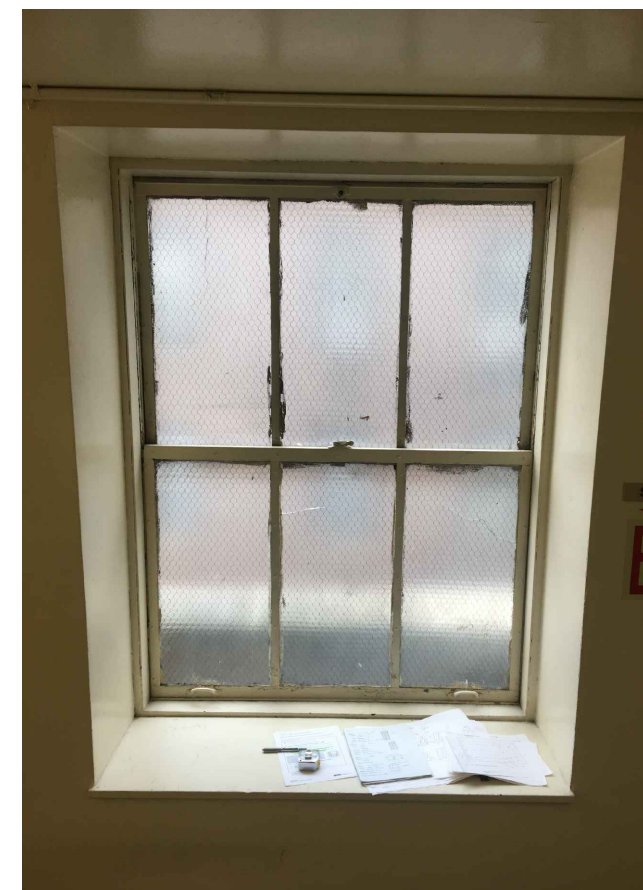

EGRESS STAIR AT REAR ELEVATION

MBB

Murphy Burnham & Buttrick Architects
48 West 37th Street, 14th Floor
New York, New York 10018
Telephone 212.768.7676
www.mbbarch.com

Congregation Rodeph Sholom
7 West 83rd Street
New York, NY 10024

Scale
N.T.S.

Date
09.14.2017
10.24.2017
11.06.2017

LM 30

Existing & Proposed
Window Type K
Rear Elevation - Not Visible

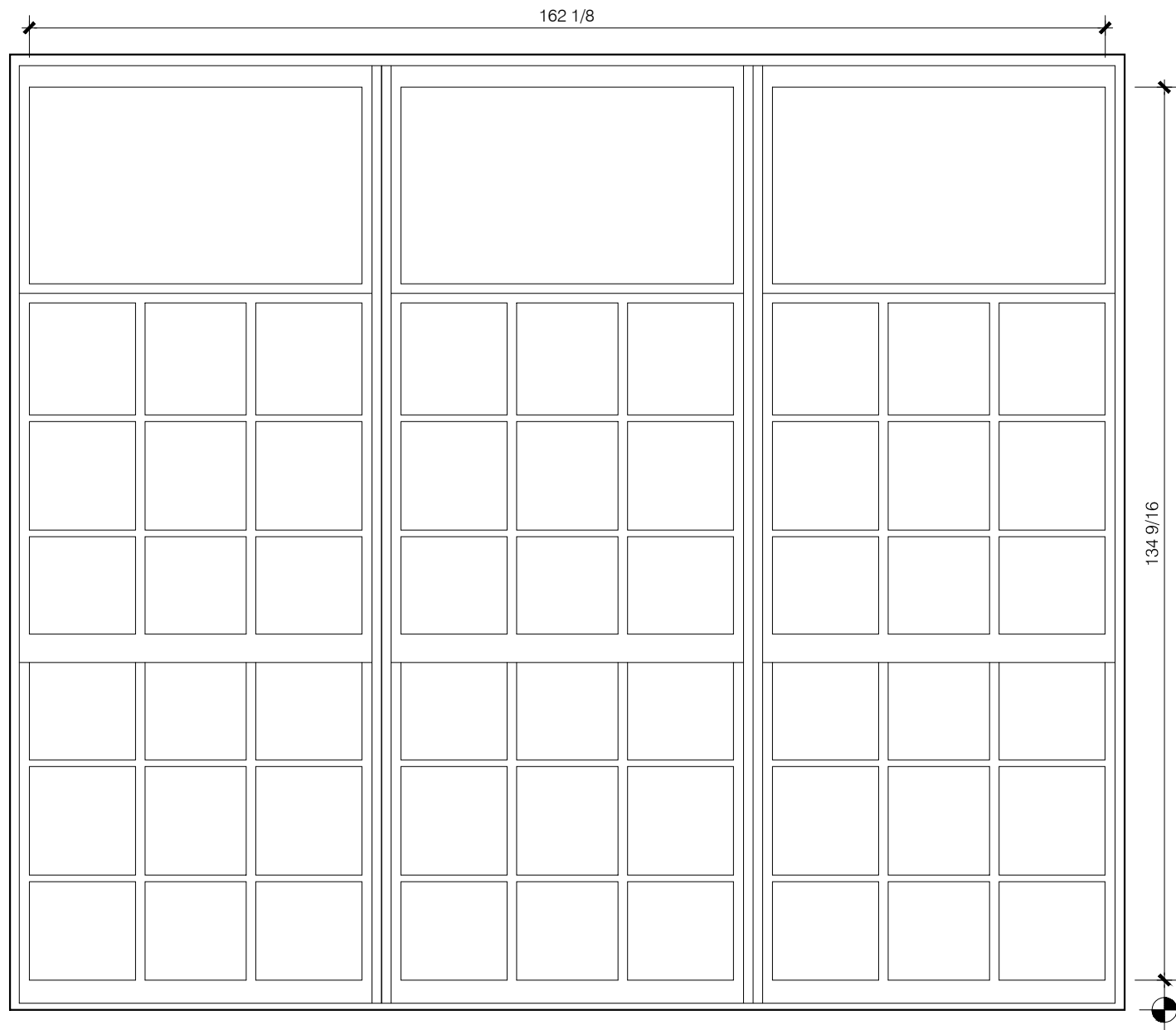

L EXG STEEL
TRANSOM OVER DOUBLE HUNG
GLASS AREA: 21816 in²

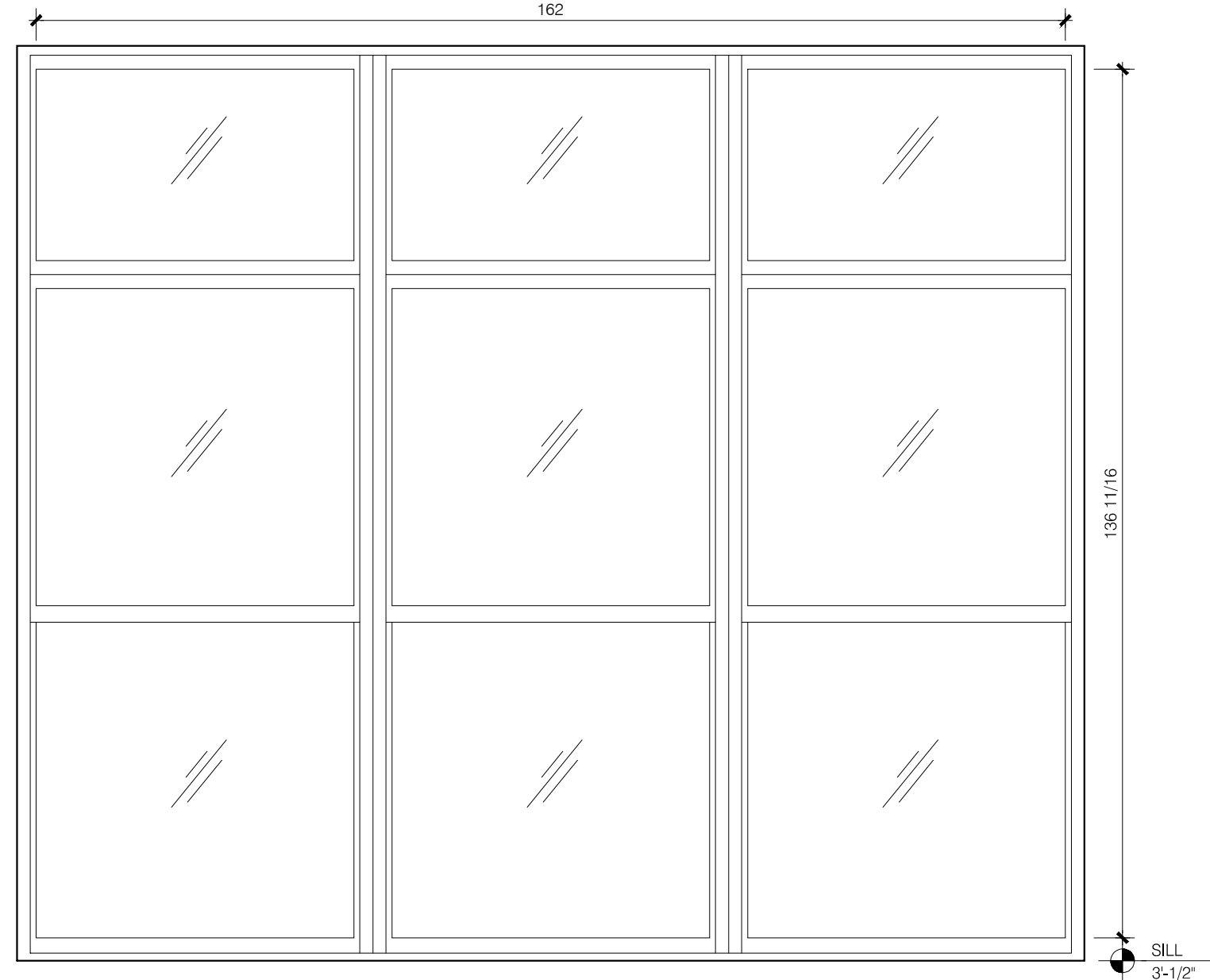

L NEW ALUMINIUM
TRANSOM OVER DOUBLE HUNG
GLASS AREA: 22143 in²
PERCENT DIFFERENCE: +1%
REAR ELEVATION
NOT VISIBLE FROM STREET

MBB

Murphy Burnham & Buttrick Architects
48 West 37th Street, 14th Floor
New York, New York 10018
Telephone 212.768.7676
www.mbbarch.com

Congregation Rodeph Sholom
7 West 83rd Street
New York, NY 10024

Scale
N.T.S.

Date
09.14.2017
10.24.2017
11.06.2017

LM 31

Existing & Proposed
Window Type L
Rear Elevation - Not Visible

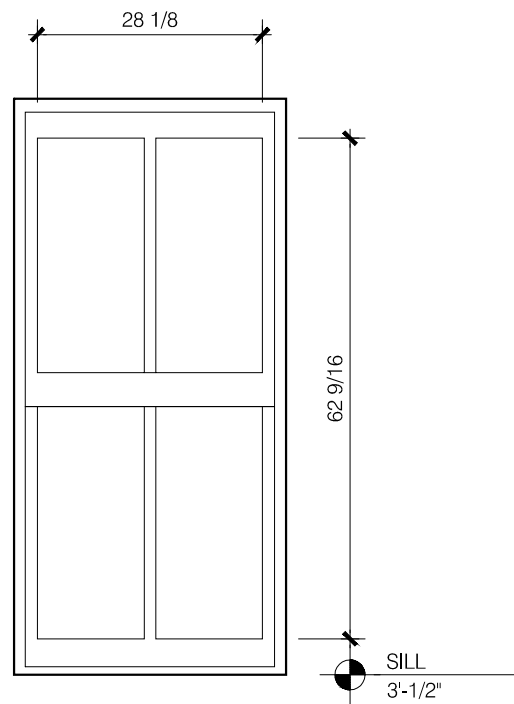

M EXG STEEL
DOUBLE HUNG
GLASS AREA: 1760 in²

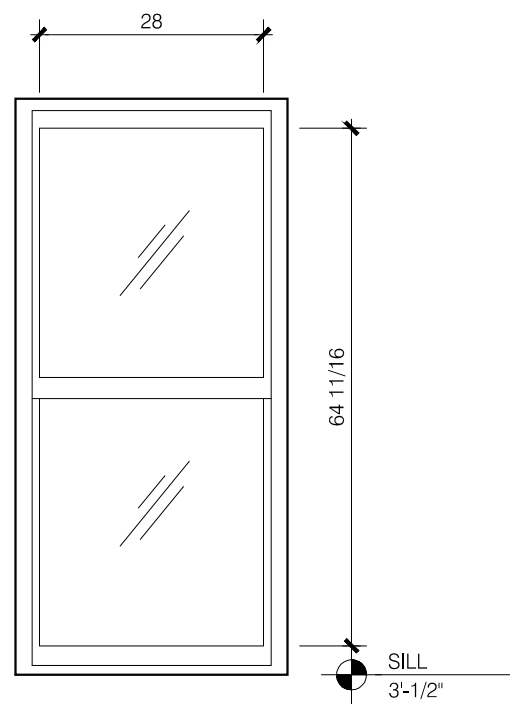

M NEW ALUMINIUM
DOUBLE HUNG
GLASS AREA: 1811 in²
PERCENT DIFFERENCE: +3%
REAR ELEVATION
NOT VISIBLE FROM STREET

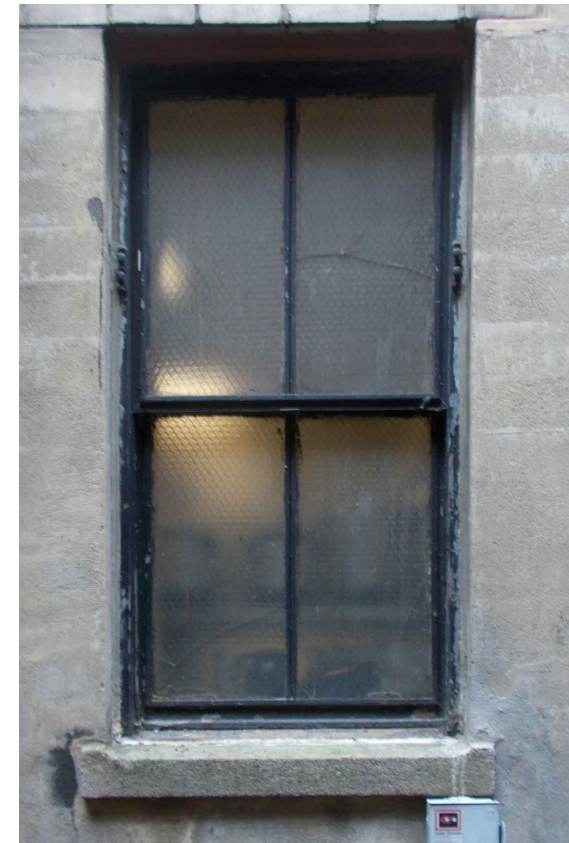

CELLAR AREAWAY BELOW GRADE

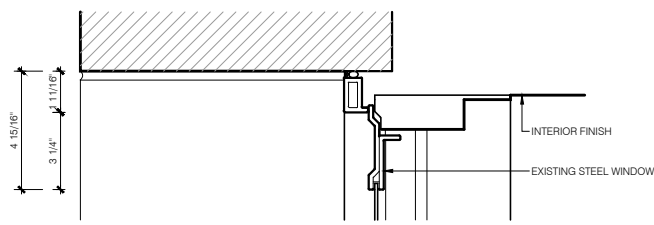

A EXISTING HEAD
WINDOW TRANSOM OVER DOUBLE HUNG

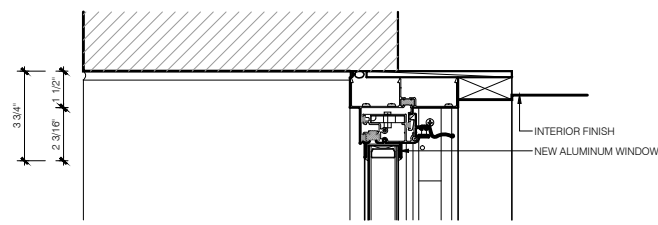

A PROPOSED HEAD
WINDOW DOUBLE HUNG

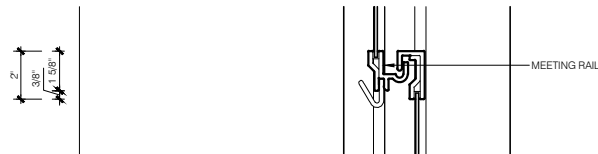

A EXISTING MEETING RAIL
WINDOW TRANSOM OVER DOUBLE HUNG

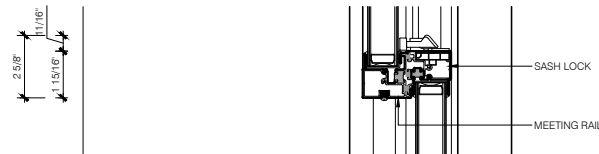

A PROPOSED MEETING RAIL
WINDOW DOUBLE HUNG

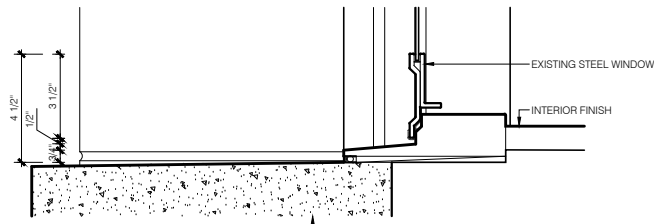

A EXISTING SILL
WINDOW TRANSOM OVER DOUBLE HUNG

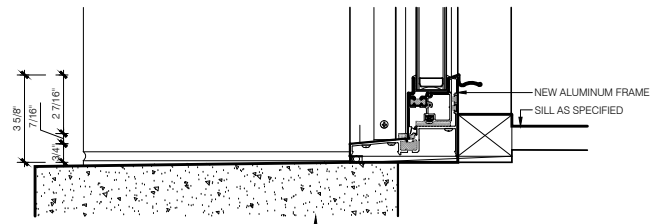

A PROPOSED SILL
WINDOW DOUBLE HUNG



A EXISTING MUNTIN
WINDOW TRANSOM OVER DOUBLE HUNG

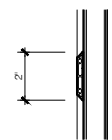

A PROPOSED SIMULATED DIVIDED LITE
WINDOW DOUBLE HUNG

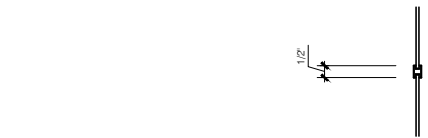

A EXISTING MUNTIN
WINDOW TRANSOM OVER DOUBLE HUNG

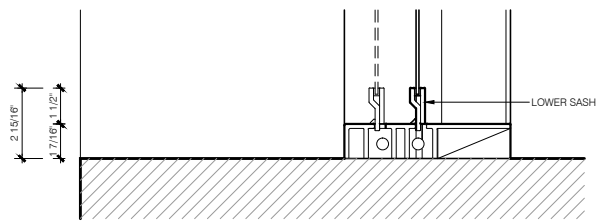
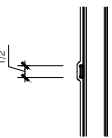

A EXISTING JAMB
WINDOW TRANSOM OVER DOUBLE HUNG

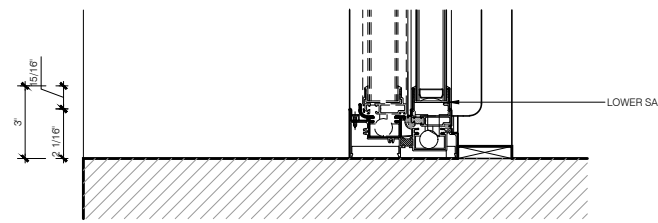

A PROPOSED JAMB
WINDOW DOUBLE HUNG

MBB

Murphy Burnham & Buttrick Architects
48 West 37th Street, 14th Floor
New York, New York 10018
Telephone 212.768.7676
www.mbbarch.com

Congregation Rodeph Shalom
7 West 83rd Street
New York, NY 10024

Scale
1 1/2" = 1'-0"

Date
09.14.2017
10.24.2017
10.30.2017
11.21.2017

LM 40

Existing & Proposed - Type A
Window Details
Steel + Aluminium

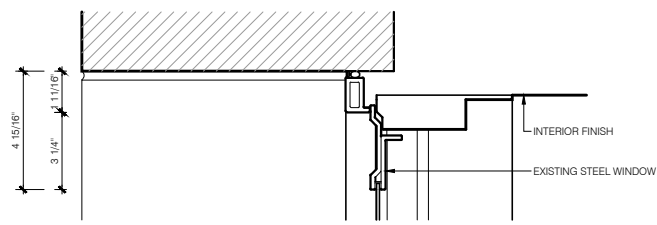

C EXISTING HEAD
WINDOW TRANSOM OVER DOUBLE HUNG

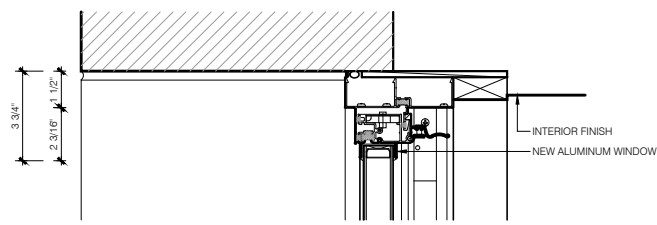

C PROPOSED HEAD
WINDOW TRANSOM OVER DOUBLE HUNG

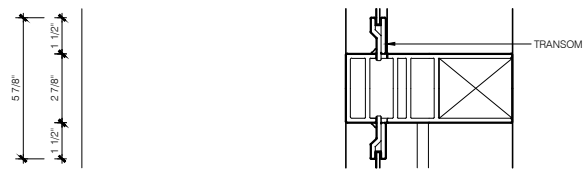

C EXISTING DETAIL AT TRANSOM
WINDOW TRANSOM OVER DOUBLE HUNG

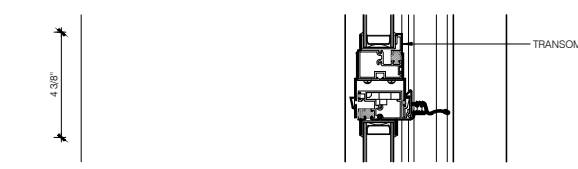

C PROPOSED DETAIL AT TRANSOM
WINDOW TRANSOM OVER DOUBLE HUNG



C EXISTING MEETING RAIL
WINDOW TRANSOM OVER DOUBLE HUNG

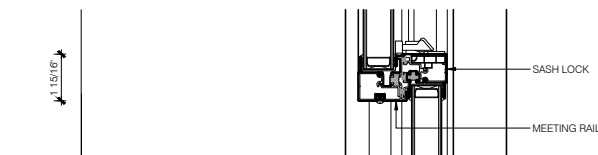

C PROPOSED MEETING RAIL
WINDOW TRANSOM OVER DOUBLE HUNG

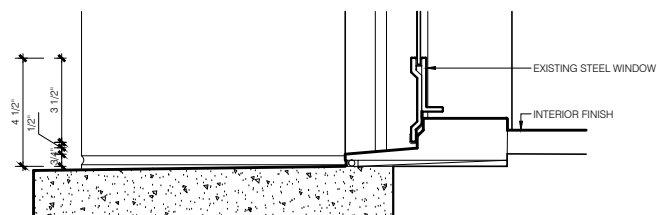

C EXISTING SILL
WINDOW TRANSOM OVER DOUBLE HUNG

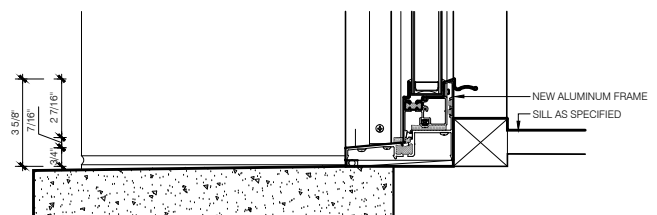

C PROPOSED SILL
WINDOW TRANSOM OVER DOUBLE HUNG



C EXISTING MUNTIN
WINDOW TRANSOM OVER DOUBLE HUNG

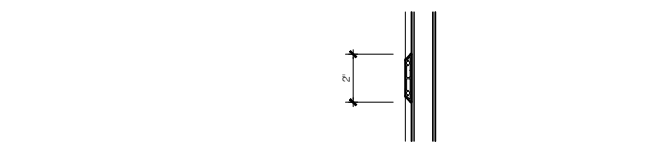

C PROPOSED SIM. DIVIDED LITE CENTER VERTICAL
WINDOW DOUBLE HUNG



C EXISTING MUNTIN
WINDOW TRANSOM OVER DOUBLE HUNG

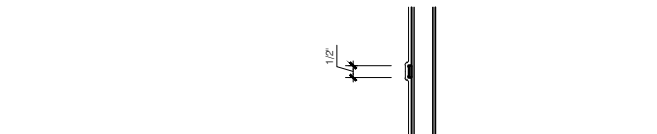

C PROPOSED SIMULATED DIVIDED LITE (TYP.)
WINDOW DOUBLE HUNG

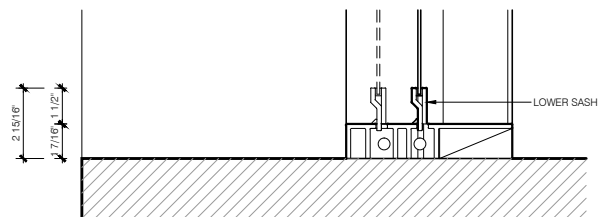

C EXISTING JAMB
WINDOW TRANSOM OVER DOUBLE HUNG

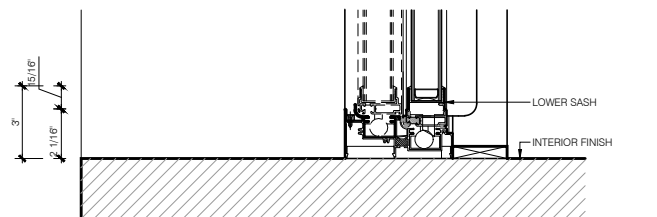

C PROPOSED JAMB
WINDOW TRANSOM OVER DOUBLE HUNG

SAMPLE SHOWN FOR
LEAD TAPE MUNTINS



01 WINDOW INTERIOR
LEAD TAPE MUNTINS - EXTERIOR ONLY



03 WINDOW EXTERIOR
LEAD TAPE MUNTINS - EXTERIOR ONLY

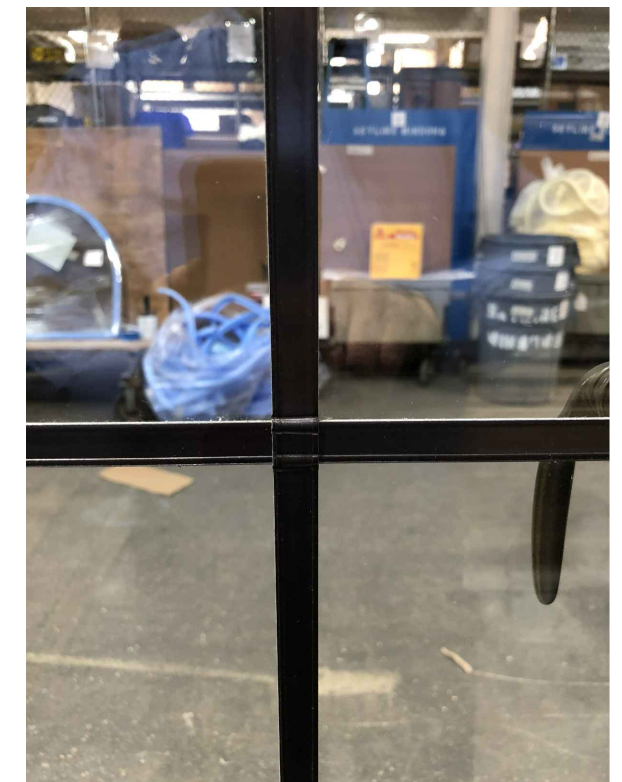

02 LEAD TAPE DETAIL
LEAD TAPE MUNTINS - EXTERIOR ONLY

MBB

Murphy Burnham & Buttrick Architects
48 West 37th Street, 14th Floor
New York, New York 10018
Telephone 212.768.7676
www.mbbarch.com

Congregation Rodeph Shalom
7 West 83rd Street
New York, NY 10024

Scale
1 1/2" = 1'-0"

Date
09.14.2017
10.24.2017
10.30.2017
11.21.2017

LM 41

Existing & Proposed - Type C
Window Details
Steel + Aluminium

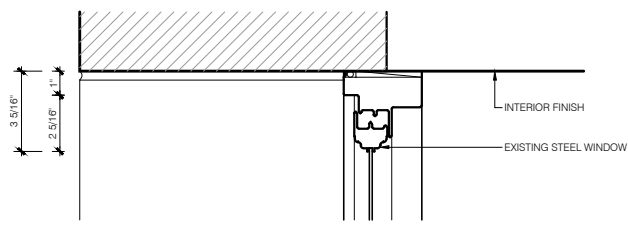

B EXISTING HEAD
WINDOW TRANSOM OVER CASEMENT

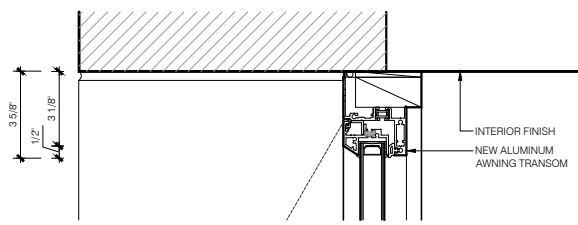

B PROPOSED HEAD
WINDOW TRANSOM OVER CASEMENT

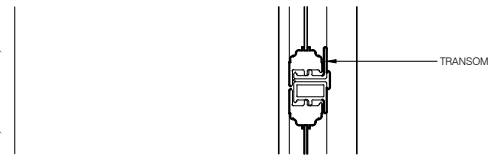

B EXISTING DETAIL AT TRANSOM
WINDOW TRANSOM OVER CASEMENT

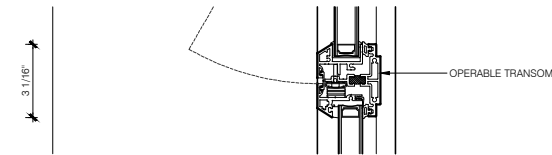

B PROPOSED DETAIL AT TRANSOM
WINDOW TRANSOM OVER CASEMENT

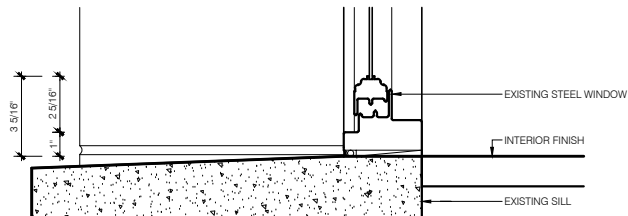

B EXISTING SILL
WINDOW TRANSOM OVER CASEMENT

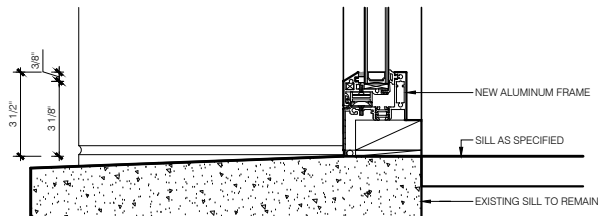

B PROPOSED SILL
WINDOW TRANSOM OVER CASEMENT

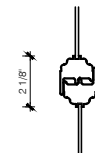

B EXSTG. MUNTIN OPERABLE TO OPERABLE
WINDOW TRANSOM OVER CASEMENT

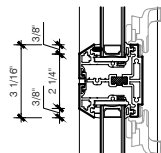

B PROP. MUNTIN OPERABLE TO OPERABLE
WINDOW TRANSOM OVER CASEMENT

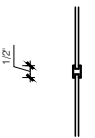

B EXISTING MUNTIN
WINDOW TRANSOM OVER CASEMENT

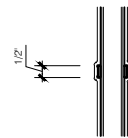

B PROPOSED SIMULATED DIVIDED LITE
WINDOW TRANSOM OVER CASEMENT

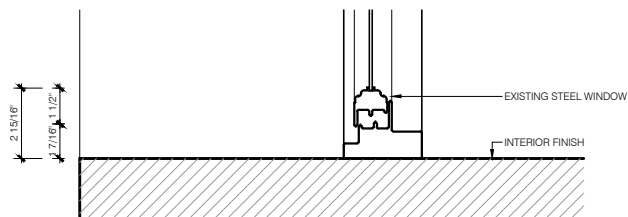

B EXISTING JAMB
WINDOW TRANSOM OVER CASEMENT

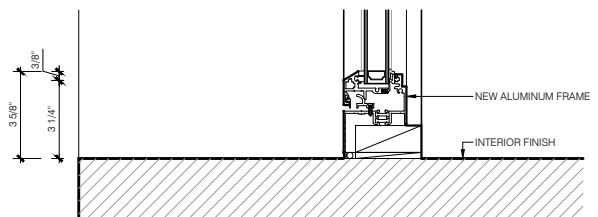

B PROPOSED JAMB
WINDOW TRANSOM OVER CASEMENT



01 WINDOW INTERIOR
LEAD TAPE MUNTINS - EXTERIOR & INTERIOR

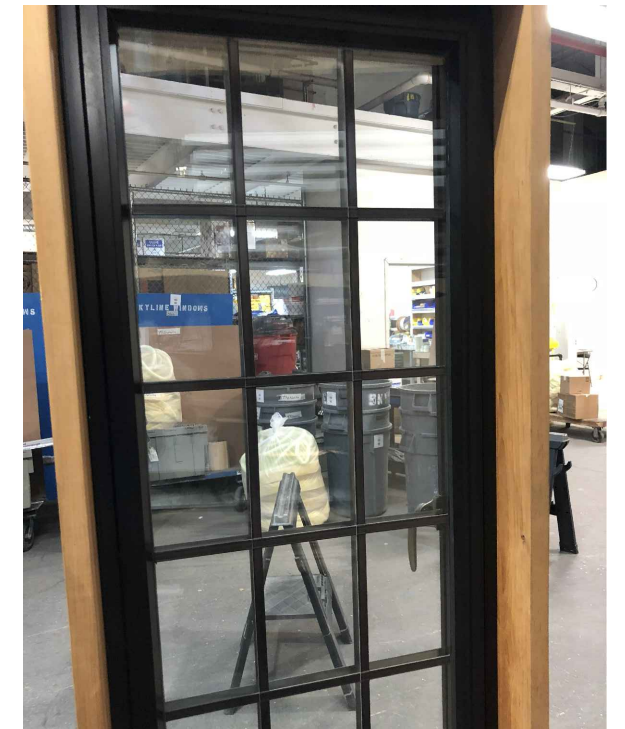

03 WINDOW EXTERIOR
LEAD TAPE MUNTINS - EXTERIOR & INTERIOR



02 LEAD TAPE DETAIL
LEAD TAPE MUNTINS - EXTERIOR & INTERIOR

MBB

Murphy Burnham & Buttrick Architects
48 West 37th Street, 14th Floor
New York, New York 10018
Telephone 212.768.7676
www.mbbarch.com

Congregation Rodeph Shalom
7 West 83rd Street
New York, NY 10024

Scale
1 1/2" = 1'-0"

Date
09.14.2017
10.24.2017
10.30.2017
11.21.2017

LM 42

Existing & Proposed - Type B
Window Details
Steel + Aluminium