



ISSUANCE #591

DEPARTMENT OF BUILDINGS

EXECUTIVE OFFICES
60 HUDSON STREET, NEW YORK, N.Y. 10013-3394
SATISH K. BABBAR, R.A., Acting Commissioner
Website: nyc.gov/buildings

(212) 312-8000
TTY (212) 312-8188

NICHOLAS J. GRECCO, P.E.
Executive Engineer
Technical Affairs
(212) 312-8140
FAX: (212) 312-8319

**TECHNICAL
POLICY AND PROCEDURE NOTICE #5/00**

TO: Distribution

FROM: Nicholas J. Grecco, PE *NJA*

DATE: October 4, 2000

**SUBJECT: SAFETY STANDARDS FOR THE ERECTION OF FLEX SIGN
STRUCTURES**

EFFECTIVE: Immediately

REFERENCE: Administrative Code Sections 27-499 and 27-501.

SUPERCEDED: Technical Policy and Procedure Notice #11/99, except for the compliance deadlines in paragraphs 1)a)i), 6)a) and 6)b).

PURPOSE: To ensure that the construction and attachments of flexible fabric sign structures will resist loads acting in any direction on the sign structure and that the sign structure will be flame resistant, and to provide guidelines for the filing of plans for and permitting of these structures.

Plans for these structures shall be filed showing compliance with this TPPN, the applicable provisions of the Building Code, and the applicable provisions of the Zoning Resolution.

SPECIFICS:

Definition: *FLEX SIGN STRUCTURE* – includes the fabric display area, the restraining framework, and all stiffening and fastening devices.

Requirements:

1) Fabric Properties

a) Flame Resistance

- i) The fabric shall be accepted by the M.E.A. as flame retarded in accordance with either the 1996 Edition of NFPA 701, *Standard Methods of Fire Tests for Flame-Resistant Textiles and Films*, using Test Method 2, after being subjected to the applicable exposure procedures in Chapter 13 of that standard, or the 1997 edition of UL 214, *Standard for Tests for Flame-Propagation of Fabrics and Films*, using the Large-Flame Test requirements. Such acceptance shall be obtained within six months of the effective date of this policy and procedure notice, or
- ii) Underwriters Laboratories shall list the fabric pursuant to the 1997 edition of UL 214, *Standard for Tests for Flame-Propagation of Fabrics and Films*.

b) Longevity

- i) The same fabric shall not be used for longer than twelve months.
- ii) The same fabric may be relocated and re-erected within the twelve months.
- iii) No re-inking of fabrics shall be permitted.

c) Attestation and Labeling

- i) The sign graphics producer shall furnish an affidavit attesting that the sign was made from fire retardant or noncombustible fabric. The affidavit shall specify the applicable MEA number or UL Classification Mark obtained from the manufacturer of the fabric.
- ii) The licensed sign hanger shall affix a decal bearing the MEA number or UL Classification Mark specified in 1c i above, and the date of erection of the flex sign structure, to a corner of the face of the sign fabric. This decal shall be of color(s) contrasting with those of the background of the display, and shall be readable from street or roadway level with the aid of binoculars.
- iii) If the same fabric is relocated, the existing decal shall remain, and a new decal stating the re-erection date shall be affixed.

2) Placement

- a) The sign fabric shall not be placed in front of doors, windows, glass blocks, louvers, grilles, fire escapes, exterior stairs, balconies, marquees, wall recesses or projections unless backed by a wall sign or a projecting sign structure as provided for in paragraph 2b. The wall sign or projecting sign structure shall provide the appropriate clearance(s), and not obstruct the doors, windows, etc.
- b) When erected on walls, flexible fabric signs whose areas exceed 500 sq.ft. (46.45 m²) shall be of the open weave type, unless backed by means of a wall sign or projecting sign structure supported as required by section 27-501(c) of the Building Code. Such sign structure shall be constructed entirely of noncombustible materials except as provided in section 27-507(a) of the Building Code.
- c) No part of the flex sign structure may project beyond an interior lot line without the written consent of all property owners affected.
- d) A licensed sign hanger shall obtain the permit for and erect the flex sign structure.

3) Fabric Securement – General

- a) Load spreader bars must be inserted around the entire perimeter of the fabric display area into pockets that are either woven, heat-welded, or stitched seamed. The load spreader bars shall be provided with rounded edges to prevent tearing of the fabric. As an alternate, the side hems of the fabric may be equipped with grommets to receive spring snaps in lieu of load spreader bars. The applicant shall determine the spacing of the grommets.
- b) Fasteners shall consist of “J” hooks secured with lock nuts or double nuts to continuous metal restraining angles around the perimeter of the display area.
- c) The sides of fabric display areas equipped with grommets as in paragraph 3a may be secured with spring snaps to vertical steel wire rope in lieu of restraining angles. The vertical steel wire rope shall be anchored to the wall or other mounting surface by means of eyebolts spaced at intervals to be determined by the applicant. The ends of the vertical steel wire rope shall be restrained by means of turnbuckles or “J” hooks secured to metal angles.
- d) In lieu of “J” hooks and restraining angles, the load spreader bars in the pockets along the top edge of the fabric display area may be bolted to steel flat bars.
- e) For all flex sign structures, the metal angles and/or steel flat bars shall be secured to the wall or other mounting surface.
- f) Angles and/or bars shall not be secured to any parapet and/or wall unless the applicant has determined that the parapet and/or wall are capable of resisting the loads imposed on it by the flex sign structure. Unsatisfactory parapets

and/or walls shall be braced or otherwise reinforced as determined by the applicant, prior to the erection of the flex sign structure. A wall sign, projecting sign, roof sign or ground sign structure must be capable of resisting the loads imposed on it by the flex sign structure.

- g) The "J" hooks shall extend through holes in the load spreader bars. The ends of the "J" hooks shall be secured with either safety clips or nuts in order to prevent accidental dislodging of the load spreader bars.
- h) Initial tension may be applied mechanically to the fabric display area, but it shall be held in final position by adjusting/tightening the turnbuckles, or the nuts holding the "J" hooks to the restraining angles. Mechanical tensioning devices may not remain attached to the flex sign structure, except as provided in paragraphs 4c through 4f.

4) Fabric Securement – Wall Sign, Projecting Sign, Roof Sign, or Ground Sign Structures

- a) If the fabric will be stretched around any edge of a wall sign, projecting sign, roof sign or ground sign structure, it shall be protected from any sharp edge that may cut or tear it.
- b) The perimeter of the fabric located on the front or rear of the wall sign, projecting sign, roof sign or ground sign structure shall be secured as required in paragraphs 3a through 3g, except that the "J" hooks may be secured directly to the structural supports of the wall sign, projecting sign, roof sign or ground sign, if deemed appropriate by the applicant.
- c) If opposite ends of the fabric are stretched around the edges of a wall sign, projecting sign, roof sign or ground sign structure, and are secured to each other by means of mechanical tensioning devices behind the sign structure, the mechanical tensioning devices may remain in place as follows. The open ends of their "S" hooks shall be closed with safety clips, or spring snaps shall be used in lieu of "S" hooks. Safety wires shall be provided. The safety wires shall be placed through holes in the load spreader bars. The mechanical tensioning devices shall also be fastened to the safety wires to prevent their falling off the flex sign structure in the event of loss of tension. The applicant must determine the thickness and spacing of the safety wires.
- d) Mechanical tensioning devices may remain in place on the front of a wall sign, projecting sign, roof sign or ground sign structure if they are secured to metal restraining angles installed pursuant to paragraph 3e and the safety wires shall also extend through holes in the restraining angles.
- e) On wall sign, projecting sign and roof sign structures, the fabric length perpendicular to the edge of the sign structure, and/or the safety wire length shall be dimensioned such that in the event of failure of any part of the flex sign structure, no load spreader bars, mechanical tensioning devices, clamps,

and/or wires will strike doors, windows, vents, chimneys, grilles, skylights, light fixtures, decorations and/or other wall appurtenances, or mechanical equipment. The safety wires may be attached to the structural supports of the sign structure if the applicant deems appropriate.

- f) For wall signs, projecting signs and ground signs, no dislodged load spreader bars, mechanical tensioning devices, clamps, and/or wires shall be permitted to fall within ten ft. (3.050 m) of grade.

5) Light Fixtures

Supports for light fixtures, if provided, shall be designed to resist the appropriate wind load from Table RS 9-5.1 of RS 9-5 of the Building Code, applied over an area equal to the longest dimension of the fabric multiplied by either twice the center-to-center spacing of the fixtures, or twice the length perpendicular to the flex sign structure of a typical fixture support, whichever is longer.

6) Compliance – Existing Flex Sign Structures

- a) All flex sign structures existing on the effective date of this Policy and Procedure Notice shall comply with its provisions no later than March 1, 2000, except that replacements of fabric display areas of existing flex sign structures performed before March 1, 2000 shall comply with paragraphs 2a and 2c as of the date of replacement.
- b) All replacements of fabric display areas of existing flex sign structures performed before March 1, 2000 shall either comply with all the other provisions of this Policy and Procedure Notice, or with the following: All mechanical tensioning devices which will remain in place (until March 1, 2000), together with any straps, load spreader bars or wire rope secured in place by such devices, shall be fastened to metal restraining angles and to steel safety wires secured to the metal restraining angles in order to prevent their falling in the event of loss of tension or tearing of the fabric. The edges of the fabric display area shall be stiffened only by means of load spreader bars. The side hems may be stiffened by means of steel wire rope as provided in paragraphs 3a and 3c. Steel flat bars may be used in lieu of metal restraining angles at the top edge of the fabric as provided for in paragraph 3d. Fabric display areas exceeding 500 sq.ft. (46.45 m²) erected on walls shall be replaced only by fabrics of the open weave type, unless a wall sign or projecting sign structure is installed pursuant to paragraph 2b.

7) Applicant

The applicant for approval of the flex sign structure shall be a P.E./R.A. who shall determine the required weight and/or strength of the fabric, the number of “J” hooks or bolts needed to secure the fabric, the method of securing the

angles and/or flat bars to the wall or other mounting surface, and the manner of securing the fastening devices to the safety wires.

8) Borough Commissioner

Subject to the review and approval of the borough commissioner, applicants may recommend the use of flex sign structural systems not described in this technical policy and procedure notice, on condition that these alternative systems provide equivalent redundant support mechanisms ensuring at least the same degree of public safety as those systems described herein, and may devise alternate methods of determining the loads that torn/dislodged fabrics are likely to impose on the light fixture supports.

9) Sample Details/Sections

Sample details/sections complying with the foregoing requirements are shown on the following pages. These are for illustrative purposes only.

SAMPLE FLEX SIGN DETAILS/SECTIONS

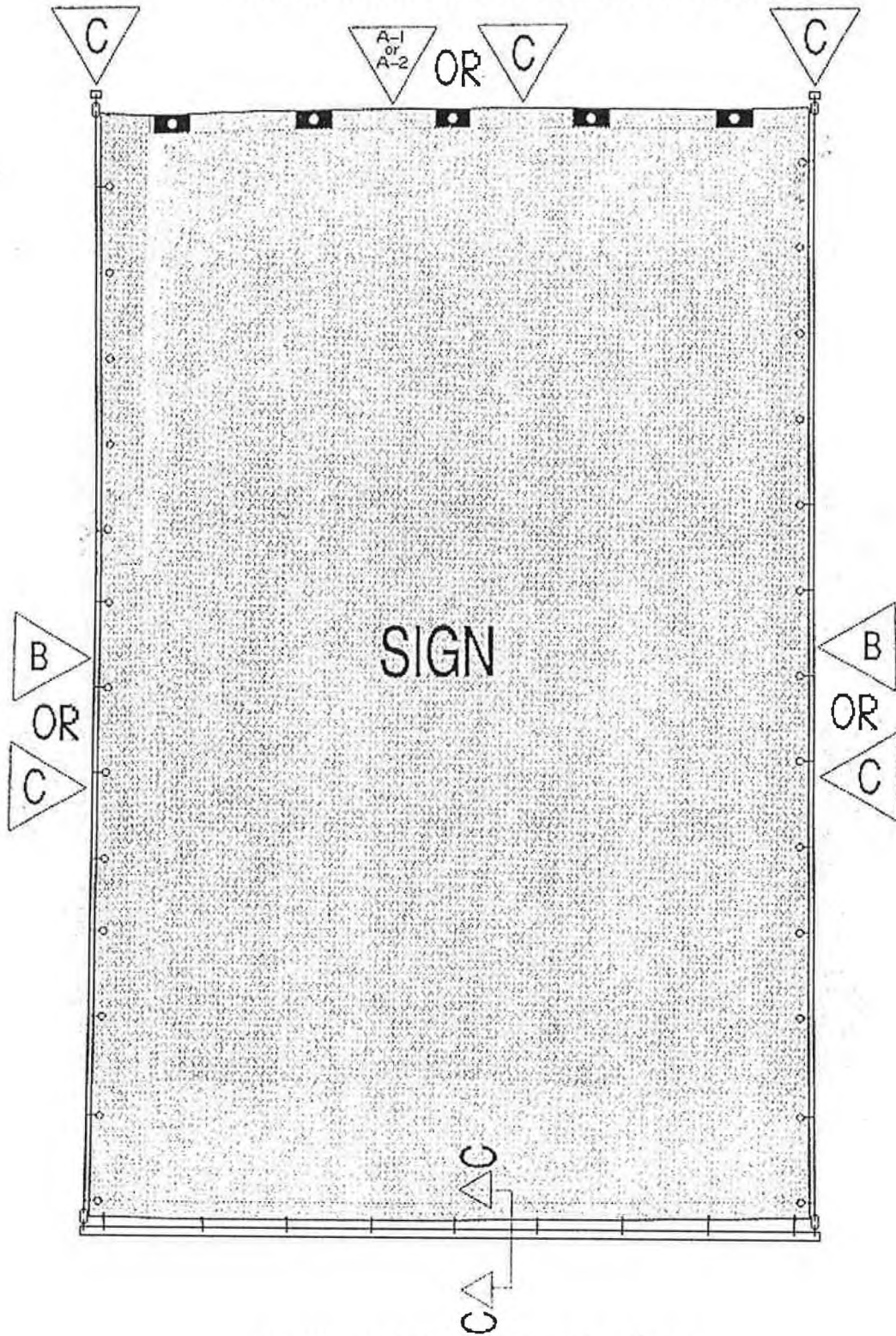

FLEX SIGN FACE - FRONT VIEW

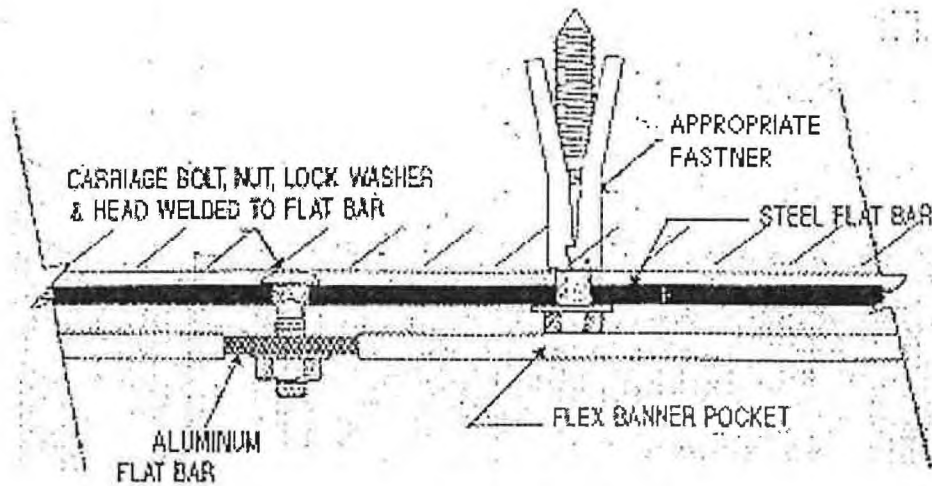

DETAIL A-1
WALL ANCHOR INSTALLATION PLAN

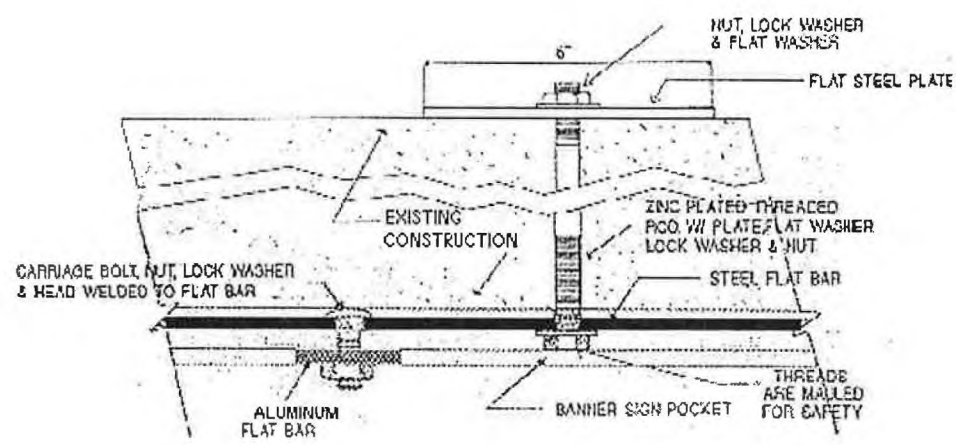

DETAIL A-2
THRU BOLT INSTALLATION PLAN
(AT EACH END)

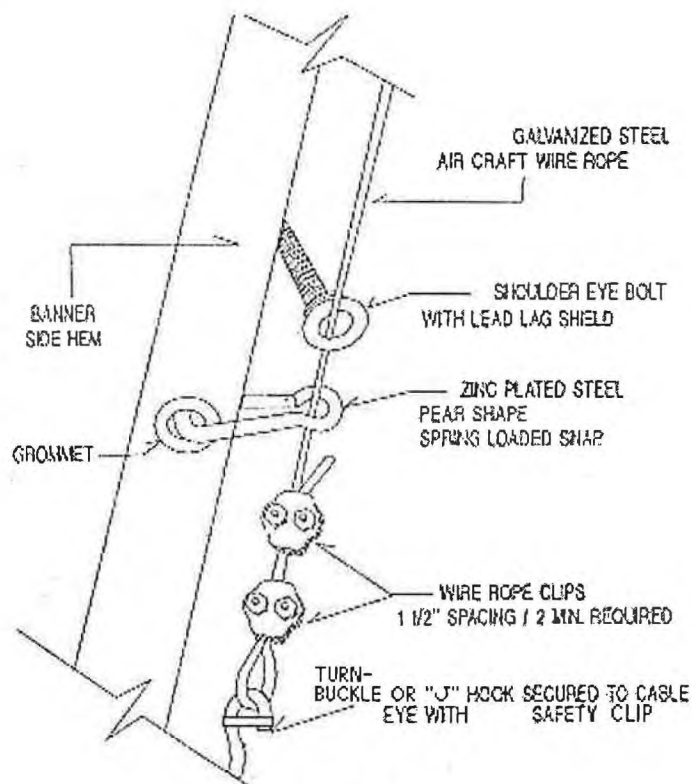

DETAIL B
SIDE CABLE ASSEMBLY

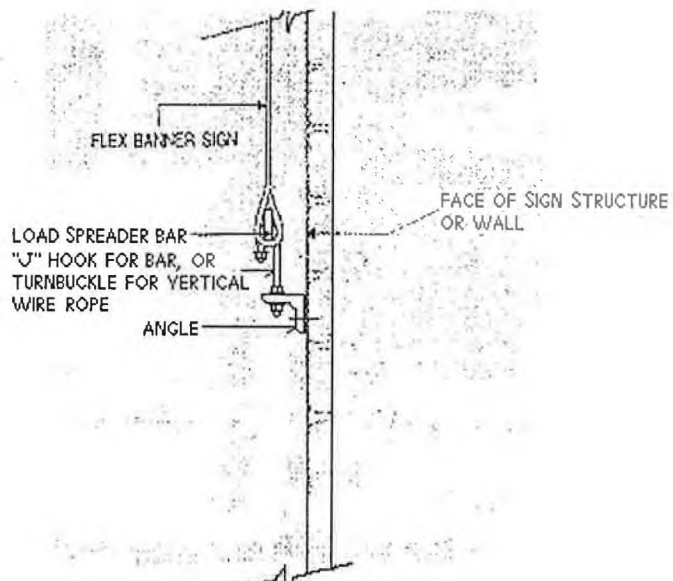

SECTION C
SECUREMENT TO
RESTRAINING ANGLES

ALTERNATE SECTION/DETAIL "C"

FOR USE ON FACE OF WALL SIGN, PROJECTING SIGN, ROOF SIGN OR GROUND SIGN STRUCTURE

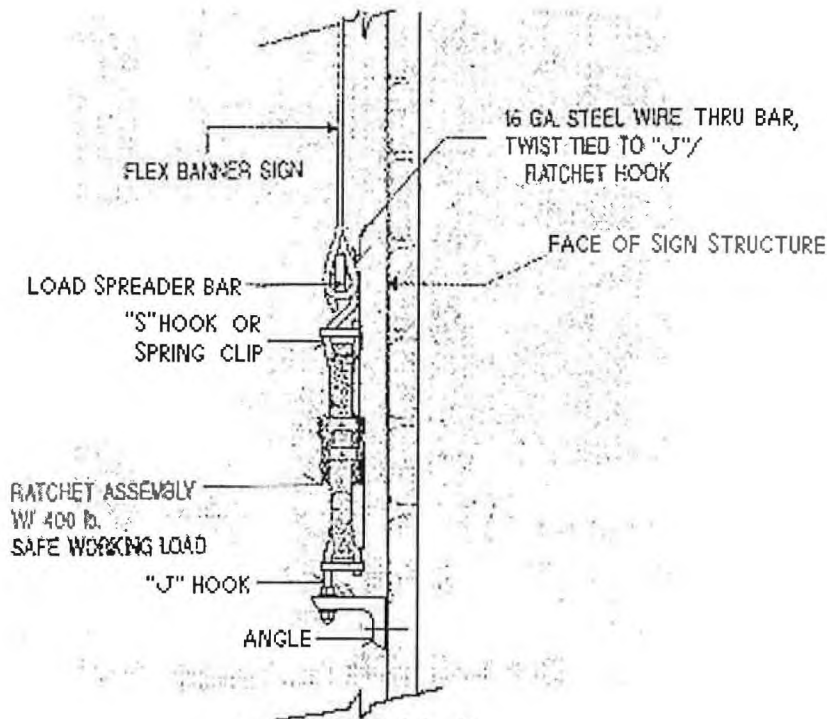

SECTION C

MAY BE USED ON WALLS UNTIL
COMPLIANCE DEADLINE

NOTES:

1. ALL HOOKS WILL BE SECURED WITH EPOXY COATED 16 GA. SAFETY WIRE.
2. ALL BOLTS, NUTS AND WASHERS ARE CADMIUM PLATED.

**FLEX SIGNS WRAPPED AROUND WALL SIGN, PROJECTING SIGN,
ROOF SIGN OR GROUND SIGN STRUCTURES**

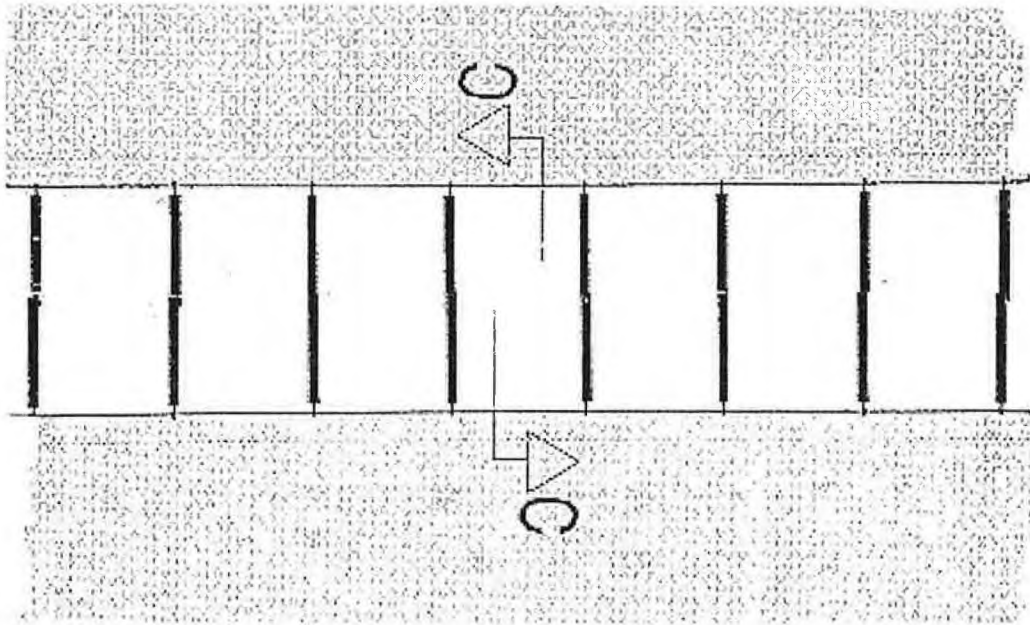

**OPTIONAL--BACK OF WALL, ROOF,
PROJECTING, OR GROUND SIGN**

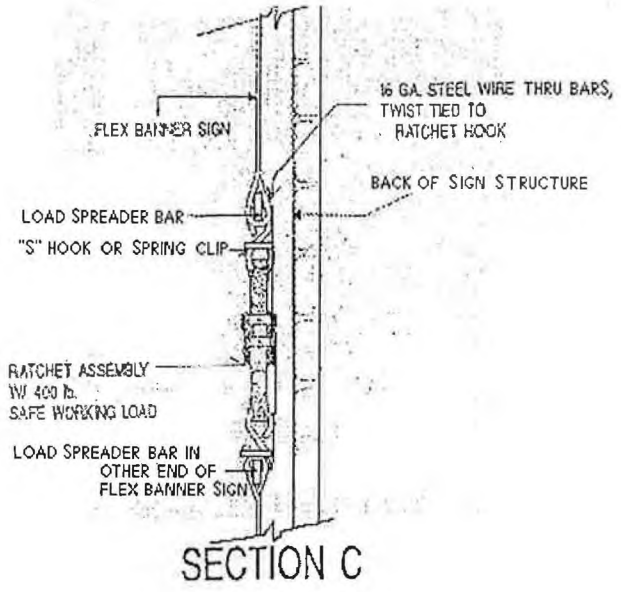

- NOTES:**
1. ALL HOOKS WILL BE SECURED WITH EPOXY COATED 16 GA. SAFETY WIRE.
 2. ALL BOLTS, NUTS AND WASHERS ARE CADMIUM PLATED.