



THE CITY OF NEW YORK MANHATTAN COMMUNITY BOARD 3

59 East 4th Street - New York, NY 10003

Phone (212) 533-5300

www.cb3manhattan.org - mn03@cb.nyc.gov

Paul Rangel, Board Chair

Susan Stetzer, District Manager

Community Board 3 Liquor License Application Questionnaire

NOTE: ALL ITEMS MUST BE SUBMITTED FOR APPLICATION TO BE CONSIDERED.

The following items and questionnaire package are due by date listed in email invite:

- Schematics, floor plans or architectural drawings of the inside of the premise.
- A proposed food and or drink menu.

The following items are due by noon Friday before the meeting:

- Petition in support of proposed business or change in business with signatures from residential tenants at location and in buildings adjacent to, across the street from and behind proposed location. Petition must give proposed hours and method of operation. For example: restaurant, sports bar, combination restaurant/bar. (petition provided)
- Notice of proposed business to block or tenant association if one exists. You can find community groups and contact information on the CB 3 website:
<https://www1.nyc.gov/site/manhattancb3/resources/community-groups.page>
(this is not required but strongly suggested if a relevant group exists)
- Proof of conspicuous posting of notices at the site for 7 days prior to the meeting (please include newspaper with date in photo or a timestamped photo).

Check which you are applying for:

- new liquor license alteration of an existing liquor license corporate change

Check if either of these apply:

- sale of assets upgrade (change of class) of an existing liquor license

Today's Date: July 29, 2022

Is location currently licensed? Yes No Type of license: There is a pending OP Liquor license: 1347367

If alteration, describe nature of alteration: _____

Previous or current use of the location: Bar / Restaurant

Corporation and trade name of current license: Pending license: Downtown Avenue Hospitality LLC

APPLICANT:

Premise address: 210 Avenue A, New York, NY 10009

Cross streets: Avenue A/13th Street

Name of applicant and all principals: Alphabet City Group, LLC; Ronan Downs, Roberta Souza, Scott Connolly, Paul O'Connor, Jack Crown

Trade name (DBA): TBD

PREMISE:

Type of building and number of floors: 4 story multi unit

Does premise have a valid Certificate of Occupancy, including for any back/side yard or roof use?

Yes No What is maximum NUMBER of people permitted 130 (TCO being reactivated)

What is the zoning designation (check zoning using map: <http://gis.nyc.gov/doitt/nycitymap/> - please give specific zoning designation, such as R8 or C2): C1-6A

PROPOSED METHOD OF OPERATION:

What are the proposed days/hours of operation? (Specify days and hours each day and hours of outdoor space, if applicable) _____

Indoors: 4:00pm-12am (Mon-Tues), 4:00pm-2:00am (Wed), 4:00pm-4:00am (Thurs-Fri), 12:00pm-4:00am (Sat), 12:00pm-2am (Sun)

Outdoors: 4:00pm-11:00pm (Monday - Friday), 12:00pm-11pm (Sat-Sun)

Will any other business besides food or alcohol service be conducted at premise, i.e., retail? Yes No

If yes, please describe what type: _____

Number of indoor tables? 23 Total number of indoor seats? 104

How many stand-up bars/bar seats are located on the premise (number, length, and location) _____
1 bar, 23', ground floor; 14 stools

(A **stand-up bar** is any bar or counter -with seating or not- where you can order, pay for, and receive alcohol)

Does premise have a full kitchen? Yes No

Does it have a food preparation area? Yes No (If any, show on diagram)

Is food available for sale? Yes No If yes, describe type of food and submit a menu _____
American Fusion

What are the hours the kitchen will be open? Kitchen will be open until one hour before closing

Will a manager or principal always be on site? Yes No If yes, which? Jack Crown

How many employees will there be? 30

Do you have or plan to install French doors accordion doors or windows?

Will there be TVs/monitors? Yes No (If Yes, how many?) 4

Will premise have music? Yes No

If Yes, what type of music? Live musician DJs Streaming services/playlists

If other type, please describe jazz, acoustic

What will be the music volume? Background (conversational) Entertainment (live music venue level) Please describe your sound system: 8 six inch, non-vibrating JBL speakers (no subs)

Will you host any promoted events, scheduled performances, or any event at which a cover fee is charged? If Yes, what type of events or performances are proposed and how often? No

If promoted events, please explain the nature in which you plan to promote? Social media / online ads / outside promoters? _____

How do you plan to manage vehicular traffic and crowds on the sidewalk caused by your establishment? Please attach plans. (Please do not answer "we do not anticipate congestion.") Staff will monitor entrance to ensure that crowds do not form, as well as vehicular traffic for congestion.

Will there be security personnel? Yes No (If Yes, how many and when) _____
1 security personnel during busy periods

How do you plan to manage noise inside and outside your business so neighbors will not be affected? Please attach plans. Soundproofing has been installed. Music will be kept at an ambient level.

Is sound proofing installed? Yes No

If not, do you plan to install sound proofing? Yes No

Are there current plans to use the Open Restaurants program for the sale or consumption of alcoholic beverages outdoors? (includes roof & yard) Yes No If Yes, describe and show on diagram:
6 Tables and 24 seats on Avenue A, 2 Tables and 4 seats on sidewalk

APPLICANT HISTORY:

Has this corporation or any principal been licensed for sale of alcohol previously? Yes No

If yes, please indicate name of establishment: See attached

Address: _____ Community Board # _____

Dates of operation: _____

Has any principal had work experience similar to the proposed business? Yes No If Yes, please attach explanation of experience or resume. Note: failure to disclose previous experience or information hampers the ability to evaluate this application.

Does any principal have other businesses in this area? Yes No If Yes, please give trade name, address and describe the business See attached

Has any principal had SLA reports or action within the past 5 years? Yes No If Yes, attach list of violations and dates of violations and outcomes, if any. See attached

Attach a separate diagram that indicates the location (**name and address**) and total number of establishments selling/serving beer, wine (B/W) or liquor (OP) for 2 blocks in each direction. Please indicate whether establishments have On-Premise (OP) licenses. Please label streets and avenues and identify your location. Use letters to indicate **Bar**, **Restaurant**, etc. The diagram must be submitted with the questionnaire to the Community Board before the meeting.

LOCATION:

How many licensed establishments are within 1 block? 8

How many On-Premise (OP) liquor licenses are within 500 feet? 8

Is the premise within 200 feet on the same street of any school or place of worship? Yes No

COMMUNITY OUTREACH:

Please see the Community Board website to find block associations or tenant associations in the immediate vicinity of your location for community outreach. Applicants are encouraged to reach out to community groups, but it is not required. Also use provided petitions, which clearly state the name, address, license for which you are applying, and the hours and method of operation of your establishment at the top of each page. (Attach additional sheets of paper as necessary)

We are including the following questions to be able to prepare stipulations and have the meeting be faster and more efficient. Please answer per your business plan; do not plan to negotiate at the meeting.

1. My license type is: beer & cider wine, beer & cider liquor, wine, beer & cider
2. I will operate a full-service restaurant, specifically a (type of restaurant) American Fusion restaurant, or
 I will operate a _____,
 with a kitchen open and serving food during all hours of operation OR with less than a full-service kitchen but serving food during all hours of operation OR Other kitchen will be open until one hour before closing _____
3. My hours of operation will be:
Mon 4:00pm-12:00am ; Tue 4:00pm-12:00am ; Wed 4:00pm-2:00am ;
Thu 4:00pm-4:00am ; Fri 4:00pm-4:00am ; Sat 12:00pm-4:00am ;
Sun 12:00pm-2:00am . (I understand opening is "no later than" specified opening hour, and all patrons are to be cleared from business at specified closing hour.)
4. I will not use outdoor space for commercial use (including Open Restaurants) OR
 My sidewalk café hours or other outside hours (including Open Restaurants) will be 4:00pm- 11:00pm (Monday - Friday), 12:00pm-11pm (Sat-Sun)
5. I will employ a doorman/security personnel: 1 during busy periods
6. I will install soundproofing, (already installed)

7. I will close any front or rear façade doors and windows at 10:00 P.M. every night or when amplified sound is playing, including but not limited to DJs, live music and live nonmusical performances, or during unamplified performances or televised sports. I will have a closed fixed façade with no open doors or windows except my entrance door, which will close by 10:00 P.M. or when amplified sound is playing, including but not limited to DJs, live music and live nonmusical performances, or during unamplified performances or televised sports.
8. I will not have DJs, live music, third-party promoted events, any event at which a cover fee is charged, scheduled performances, more than _____ DJs per _____, more than 12 private parties per year
9. I will play ambient recorded background music only.
10. I will not participate in pub crawls or have party buses come to my establishment.
11. I will not have unlimited drink specials, including boozy brunches, with food.
12. I will not have a happy hour or drink specials with or without time restrictions OR I will have happy hour and it will end by 8:00pm.
13. I will not have wait lines outside. I will have a staff person responsible for ensuring no loitering, noise or crowds outside.
14. I will conspicuously post this stipulation form beside my liquor license inside of my business.
15. Residents may contact the manager/owner at the number below. Any complaints will be addressed immediately. I will revisit the above-stated method of operation if necessary in order to minimize my establishment's impact on my neighbors.

Name: Jack Crown

Phone Number: (347) 703-6924

Principal License History

Ronan Downs

380 East Ventures LLC

380 Third Avenue, New York, NY 10016

Manhattan Community Board 6

2018 to present

Park Stone Venture Ltd

47 East 29th Street, New York, NY 10016

Manhattan Community Board 5

2011 to present

Liam Street Venture Ltd

19 South William Street, New York, NY 10004

Manhattan Community Board 1

2010 to present

307 Third Avenue East Venture LLC

307 Third Avenue, New York, NY 10010

Manhattan Community Board 6

2010 to present

45 Stone Street Venture Ltd

45 Stone Street, New York, NY 10004

Manhattan Community Board 1

2008 to present

85 Pearl Street Venture Ltd

85 Pearl Street, New York, NY 10004

Manhattan Community Board 1

2006 to present

DSRS Montauk Venture Ltd

432 West Lake Drive, Montauk, NY 11954

2005 to 2006

9th Street Ventures, Ltd

232 East 9th Street, New York, NY 10003
Manhattan Community Board 3
1999 to 2010

RET Venture Ltd

79 Pearl Street, New York, NY 10004
Manhattan Community Board 1
1999 to present

81 Pearl Street Venture Ltd

81 Pearl Street, New York, NY 10004
Manhattan Community Board 1
1995 to present

Pearl Street Venture Ltd

78 Pearl Street, New York, NY 10003
Manhattan Community Board 1
1994 to 2004

Fulton Street Venture, Ltd

90 Fulton Street, New York, NY 10038
Manhattan Community Board 1
1990 to 2005

46 Stone Street Venture Ltd

79 Pearl Street, New York, NY 10004
Manhattan Community Board 1
1986 to present

1470 Rest. & Bar Inc.

1470 First Avenue, New York, NY 10075
Manhattan Community Board 8
1985 to 2000

Roberta Souza

380 East Ventures LLC

380 Third Avenue, New York, NY 10016
Manhattan Community Board 6
2018 to present

307 Third Avenue East Venture LLC

307 Third Avenue, New York, NY 10010
Manhattan Community Board 6
2010 to present

Scott Connolly

380 East Ventures LLC

380 Third Avenue, New York, NY 10016
Manhattan Community Board 6
2018 to present

Paul O'Connor

274 Pub On Third Inc.

274 Third Avenue, New York, NY 10010
Manhattan Community Board 6
2003 to 2011

575 Pub On Second Inc.

575 Second Avenue, New York, NY 10016
Manhattan Community Board 6
2005 – 2013

55 Stone Rest Inc.

83 Pearl Street, New York, NY 10004
Manhattan Community Board 1
2007 to present

JTP Restaurant Corp.

712 Third Avenue, New York, NY 10017
Manhattan Community Board 6
2011 to present

307 Third Avenue East Venture LLC

307 Third Avenue, New York, NY 10010

Manhattan Community Board 6

2011 to present

MD 276 Restaurant LLC

5 East 38th Street, New York, NY 10016

Manhattan Community Board 5

2014 to 2015

MDB38, LLC

5 East 38th Street, New York, NY 10016

Manhattan Community Board 5

2017 to present

53 Lapidar Inc

53 Stone Street, New York, NY 10004

Manhattan Community Board 1

2019 to present

Principal Work Experience

Ronan Downs

I moved to NYC in 1978. I am an Oneonta State College Graduate. I worked in Dressers Bar & Restaurant from 1979-1985. I opened my first business in 1985 on Upper East Side of Manhattan. The business was open for 15 years. I opened GB Shaws on Fulton Street in 1990 and sold it in 2005. I opened Becketts Bar & Grill in 1995 and is still operating. I opened Waterstone Grill in 1999 and it is still operating under the Route66 title. The building was bought in 2001. I am also involved in four other restaurants on Stone Street. Aside from investments in FiDi I also have a craft beer focused bar called Taproom and another bi-level restaurant which also has a roof garden on 29th & Park. We own this building also. In 2018, we opened Factory 380, and that is still operating.

Roberta Souza

Born in Rio de Janeiro, Roberta grew up with her mother. Her mother, a chef, raised her in the kitchen where she traded playing with dolls for peeling vegetables. At the age of 17, she came to the US following her mother's footsteps. She landed her first job as a part time coat check employee at Giovanni 's on 53rd and 5th avenue. She later started working at Becketts located in FiDi as a Hostess. Ronan was a great mentor in her early NYC days and a true friend. As the years went by, Ronan proposed they started a business together called 'Burger Burger' which was launched in 2008 and is still operating. In 2011 another opportunity came about for a craft beer concept 'Taproom307' which is located in the Gramercy area. In 2018, we opened Factory 380, and that is still operating.

Scott Connolly

Scott is a Dublin Business School Graduate with a B.A. Honors Degree in Business Management. Integrated within this course was a selection of optional elective subjects. This allowed him to obtain knowledge of other key areas of this business such as Accounting, Management , Marketing and Information Systems. After graduating he worked for a leading Dublin based Marketing company and held a managing position for a number of years. Later he entered the hospitality business in Dublin working for a consortium who owned multiple restaurants before moving to NYC and taking the management position in 'Becketts Bar & Grill' for 4 years & Bavaria Bier Haus for 1 year.

Jack Crown

Born in New York City to Irish parents, my family relocated back to Ireland when I was a young child. I began working in restaurants at age 17 in Eamon Dorans Tavern in Dublin's Temple Bar. My first role was as barback/bartender and soon as manager. Soon after having helped with the opening of a new restaurant of the same name, I relocated back to New York City with the vision of owning a bar. Upon returning to New York City in 2012, I became immediately enthralled by all facets and cultures of hospitality. I began a ten-year career in restaurants and bars that include working and managing some of the city's most famous establishments. My passion for hospitality led me to pursue a role as a volunteer at the Salvation Army's lunch service on 14th street. Over time I became one of their longest-serving volunteers and have helped with their Christmas toy drives all over the city for the past couple of years. Having spent 7 years working in East Village's Swift Hibernian Lounge and a year at The Factory, I am currently working at Corner Bistro.

Paul O'Connor Resume

Profile

As the operating partner of the JTP Restaurant Group, I oversee the daily management of and staffing for five restaurants, as well as their adherence to city and state regulations. With over 25 years' experience in multiple restaurant concepts, I am looking forward to the challenge that a new venture brings.

Skills

Concept Development	Project Management
Site Selection	Business Analysis
Brand Development	Market Analysis
Human Resources	Payroll
Information Technology	Restaurant Operations
Sales and Labour Analysis	Staff Management
Landlord Relations	Hiring

Additional Resume Items:

Self Help Africa (New York Board Member) — 2013 - Present

Self Help Africa is an international "for profit, not-for-profit" that promotes and implements long-term rural development projects in Africa. The New York board advises the Irish headquarters and raises money along with the profile of Self Help Africa in New York and the United States.

Integrated Software, Operations Consultant — 1994 - 2002

Aided in designing and implementing software to allow for variance in price and language for national and international client print publications. Trained client staff and oversaw testing, quality assurance, and support.

Greenwood Digital, Co - Founder — 2002 - 2003

Performed upgrading and transitioning for a technology consulting and training company.

inet.d, Co - Founder — 1996 - 1997

inet.d provided internet development and consulting services for such clients as Compaq, The United Nations (State of the Worlds Children '98), Pet Pantry Warehouse, Harvard Business Review, Rudy Giuliani Mayoral Campaign, and GMHC.

Education

Dublin Institute of Technology, Rathmines — 1992

FOOD MENU

SHARES

ROASTED CAULIFLOWER FLORETS V | 14

Sesame, Garlic Chips, Chili Oil & Herbs

MARGARITA PIZZA V | 14

Tomato San Marzano, Mozzarella, Parmesan, Fresh Basil & Olive Oil

DIAVOLA PIZZA | 16

Tomato San Marzano, Mozzarella, Pepperoni, Hot Honey, Parmesan, Jalapeños, Fresh Basil & Olive Oil

SHAVED TRUFFLE MAC' AND CHEESE V | 16

Penne, Pecorino, Parmesan, Cream, Garlic Crumbs

CHARCUTERIE BOARD | 19

Prosciutto San Daniele, Salami Finocchiona, Mortadella, Spicy Chorizo, Marinated Olives, Cornichons

SICHUAN PEPPERCORN CHICKEN WINGS | 13

Fresh Garlic, Ginger, Green Onion, Fresh Cilantro

SPICY TUNA TARTARE | 17

Crispy Rice, Avocado, Sriracha, Nori

BAVARIAN SOFT PRETZEL BITES | 13

Housemade Bier Cheese Dip, Stone Ground Mustard

PAN FRIED DUMPLINGS | 12

Pork Dumplings | Vegetable Dumplings V

AVENUE NACHOS' V | 15

Buffalo Chicken +4 Chicken +4 Steak +5 Cheddar, Black Beans,

Homemade Guacamole, Jalapeños, Sour Cream

HERB CRUSTED MAC AND CHEESE FRITTERS | 16

Chipotle Crema, Micro Greens V

JUMBO SHRIMP TOSTADAS

Corn Tortillas, Guacamole, Chipotle-Lime Aioli, Radish, Tomato & Red Onion Pico de Gallo

MAINS

SMASH BURGER | 15

Animal Fries +3 Beyond Patties +3 Bacon +2 Lettuce Wrapped +1

Two 3oz Beef Patties, Lettuce, Tomato, Onion, Cheese, Secret Spread, Toasted Sesame Bun, Fries

GRILLED CHEESE | 14

Bacon +2

3 Cheeses, Cheese Sauce, Caramelized Onions, Tomato, Toasted Sourdough, Tomato Soup

PEACH HABANERO BACON AND BURRATA B.L.T | 15

Tortilla Wrapped +1 Avocado +2 Peach Habanero Smoked Bacon, Arugula, Tomato, Chipotle Mayo, Toasted Sourdough, Fries

SPICY FRIED CHICKEN SANDWICH | 15

Lettuce Wrapped +1 Cheese +2 Bacon +2

Crispy Fried Chicken, Slaw, Secret Sauce, Pickles, Toasted Sesame Bun, Fries

BEEF BIRRIA TACOS | 16

Spice Infused Beef, Diced Onion, Cilantro, Corn Tortillas, Birria Broth

'BAJA STYLE' SHRIMP TACOS | 16

Creamy Baja-Style Sauce, Slaw, Cilantro, Pico De Gallo, Corn Tortillas

RIGATONI WITH PRAWNS | 16

Sautéed Shrimp, Spicy 'Nduja Salami, Roasted Red Peppers, Tomato & Fresh Basil

CREAMY CHORIZO AND ROSEMARY PASTA | 16

Penne, Tomato, Spanish Chorizo, Rosemary, Cream, Shaved Parmesan, Parsley

HONEY SESAME CHICKEN CAESAR SALAD | 16

Kale, Iceberg Lettuce, Croutons, Shaved Parmesan, Caesar Dressing, Parsley, Charred Lemon

MOZZARELLA & HEIRLOOM TOMATO SALAD V | 16

Black Olives, Fresh Basil, Garlic Coutons, Olive Oil

PAN ROASTED SALMON

Zucchini, Black Rice, Chickpeas, Pickled Cucumbers, Jalapeno Aioli

Dessert

COOKIE DOUGH LAVA CAKE | 9

Served With Big Shane's Vanilla Ice Cream

V VEGETARIAN GF GLUTEN FREE

CONSUMING RAW OR UNDERCOOKED MEATS, POULTRY, SEAFOOD, SHELLFISH OR EGGS MAY INCREASE YOUR RISK OF FOODBORNE ILLNESS



Certificate of Occupancy

CO Number:1086159-0000004

This certifies that the premises described herein conforms substantially to the approved plans and specifications and to the requirements of all applicable laws, rules and regulations for the uses and occupancies specified.No change of use or occupancy shall be made unless a new Certificate of Occupancy is issued.*This document or a copy shall be available for inspection at the building at all reasonable times.*

<p>A. Borough: MANHATTAN Address: 210 AVENUE A Building Identification Number(BIN): 1086159</p>	<p>Block Number: 407 Lot Number(s): 7502 Additional Lot Number(s): Application Type: A1 - ALTERATION TYPE 1</p>	<p>Full Building Certificate Type: Temporary Date Issued: 06/15/2022</p>
<p>This building is subject to this Building Code: 1968</p>		
<p>This Certificate of Occupancy is associated with job# 123546065-01</p>		
<p>B. Construction Classification: 3: NON-FIREPROOF STRUCTURES Building Occupancy Group classification: A-2 - ASSEMBLY: EATING & DRINKING Multiple Dwelling Law Classification: HAEA</p>		
<p>No.of stories: 4</p>	<p>Height in feet: 40</p>	<p>No.of dwelling units: 3</p>
<p>C. Parking Spaces and Loading Berths: Open Parking Spaces: Not Available. Enclosed Parking Spaces: Not Available. Total Loading Berths: Not available</p>		
<p>D. This Certificate is issued with the following legal limitations: Restrictive Declaration: None Zoning Exhibit: None BSA Calendar Number(s): None CPC Calendar Number(s): None</p>		
<p>Borough Comments:</p>		

Borough Commissioner

Commissioner



Permissible Use and Occupancy

FLOOR	Occ Group	Max. Persons Permitted	Live Loads (lbs per sq ft)	Zoning Use Group	Dwelling or Rooming Units	Job Reference	Certificate of Occupancy Type	CO Expiration Date
Cellar	S-2	N/A	OG	6		CO 117614	Final	
Description of Use: Storage of non combustible materials STORAGE, CRAWL SPACE (NO CHANGE)						Exceptions:		
Floor 1	A-2	130	100	6		123546065	Temporary	09/13/2022
Description of Use: Eating and Drinking EATING AND DRINKING ESTABLISHMENT (BITE BAR)						Exceptions:		
Floor 1	A-2	64	100	6		123546065	Temporary	09/13/2022
Description of Use: Eating and Drinking EATING AND DRINKING ESTABLISHMENT (FAT BUDDA)						Exceptions:		
Floor 2	R-2	N/A	40	2	1	CO 117614	Final	
Description of Use: Apartment House ONE(1) DWELLING UNIT						Exceptions:		
Floor 3	R-2	N/A	40	2	1	CO 117614	Final	
Description of Use: Apartment House TWO(2) LOWER DUPLEXES						Exceptions:		



Permissible Use and Occupancy

FLOOR	Occ Group	Max. Persons Permitted	Live Loads (lbs per sq ft)	Zoning Use Group	Dwelling or Rooming Units	Job Reference	Certificate of Occupancy Type	CO Expiration Date
Floor 4	R-2	N/A	40	6	1	CO 117614	Final	
Description of Use: Apartment House TWO(2) UPPER DUPLEXES						Exceptions:		

CofO Comments: NOTE: THIS SITE IS COMPRISED OF FIVE (5) BUILDINGS ON A SINGLE ZONING LOT CEL, 2, 3, 4- NO CHANGE(EXISTING- FINAL_ 117614

Borough Commissioner

Commissioner

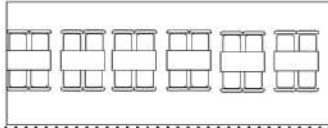

Avenue A

Block 1234 Street



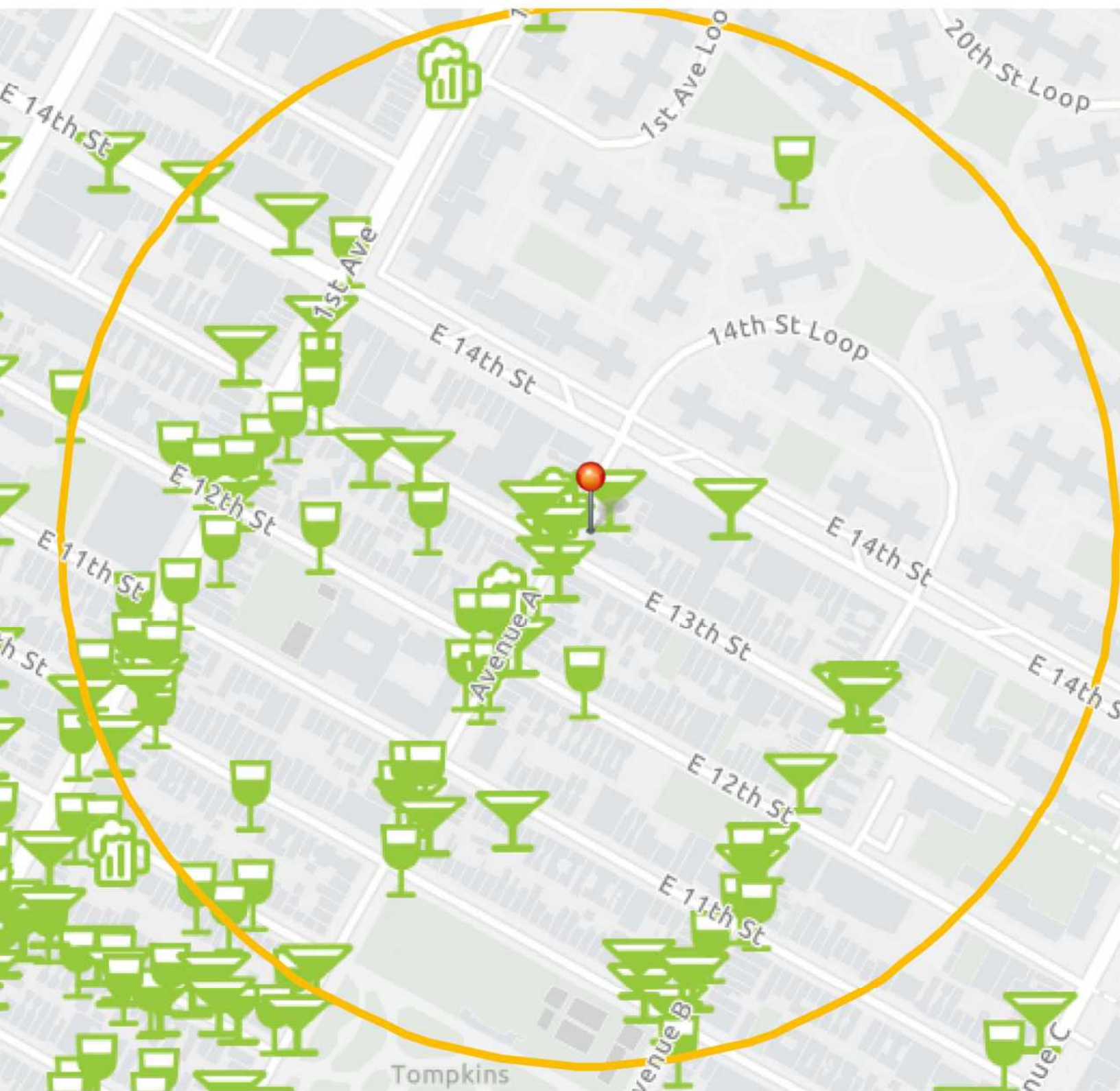

On Premises Liquor Licenses

1. FAT PANDA INC - 219 Avenue A North, 79.66 ft
2. FRIDA & DIEGO CORP - 211 Avenue A, 88.23 ft
3. PUB 218 CORP - 218 Avenue A, 95 ft
4. DBW RESTAURANT ASSOCIATES LLC - 206 Avenue A, 130.57 ft
5. TAVERN 211 CORP - 211 Avenue A, 223.77 ft
6. MONOLITH INC - 194 Avenue A, 320.82 ft
7. SPT CORP - 538 East 14th Street, 327.2 ft
8. HUGHES MURRAY WALSH LLC - 447 East 13th Street, 513.58 ft
9. GHD INC - 432 East 13th Street, 589.74 ft
10. DELTA 510 CORP - 510 East 11th Street, 660.47 ft
11. 224 AVENUE B INC - 224 Avenue B, 673.72 ft
12. 220 ASSOCIATES INC - 222 Avenue B, 692.72 ft
13. LEAD TO GOLD INC - 225 Avenue B, 695.86 ft
14. 219 AVENUE B MUSIC LOUNGE INC - 219 Avenue B, 715.7 ft
15. PATTY MC CARTHYS INC - 169 Avenue A, 716.71 ft
16. FLAM ABLE LLC - 204 Avenue B, 728.48 ft
17. A10TH KITCHEN GROUP INC - 162 Avenue A, 746.28 ft
18. MACCG LLC - 228 1st Avenue, 783.22 ft
19. HEARTH RESTAURANT INVESTORS LLC - 403 East 12th Street, 795.18 ft
20. AMA FOOD GROUP LLC - 190-192 Avenue B, 800.35 ft
21. RUE B CORP - 188 Avenue B, 850.3 ft
22. EST RESTAURANT CORP - 349 East 13th Street, 890.73 ft
23. BEFORE THAI INC - 347 East 14th Street, 956.68 ft
24. FOOD IN ITALY LLC - 337 East 10th Street, 978.87 ft
25. 162 4 AVE B BAR - 162 164 Avenue B, 1,006.37 ft
26. OOPS OF NEW YORK INC - 168 Avenue B, 1,013.8 ft
27. CHARLEY GROUP LLC - 339 East 10th Street, 1,017.7 ft
28. CGJC HOLDINGS LLC - 168 1st Avenue, 1,031.43 ft
29. AGN RESTAURANT LLC - 166 1st Avenue, 1,065.1 ft
30. YARDBIRD LLC - 162 Avenue B, 1,083.88 ft
31. WISHBONE PRODUCTIONS INC - 141 Avenue A, 1,145.17 ft
32. JARLENE CORP - 160 1st Avenue, 1,153.4 ft
33. ATS RESTAURANT CORP - 349 East 14th Street, 1,153.5 ft

On Premises Beer and Wine Licenses

1. ZARAGOZA MEXICAN DELI & GROCERY INC - 215 Avenue A, 102.16 ft
2. BAKER'S PIZZA INC - 201 Avenue A, 284.97 ft
3. BORIS & HORTON EAST VILLAGE LLC - 195 Avenue A, 290.65 ft
4. TWOBONES CATERING LLC - 441 East 12th Street, 320.96 ft
5. LE VRAIE RACLETTE LLC - 511 East 12th Street, 353.87 ft
6. LUTHUN LLC - 432 434 East 13th Street, 375.36 ft
7. 188 AVE A TAKE OUT FOOD CORP - 188 Avenue A, 410.81 ft
8. 186 A ENTERPRISES INC - 186 Avenue A, 412.53 ft
9. BE A GOOD NEIGHBOR LLC - 189 Avenue A, 414.68 ft
10. WOMAN IN WINE LLC - 413 East 12th Street, 641.19 ft
11. WESTVILLE RESTAURANT INC - 173 Avenue A, 648.78 ft
12. MAMAS COOKING II LLC - 171 Avenue A, 666.99 ft
13. ICHIBANTEI PUB INC - 401 East 13th Street, 673.35 ft
14. SADGURU INC - 222 1st Avenue, 704.06 ft
15. KOKO SUSHI CORP - 214 1st Avenue, 710.5 ft
16. MAMA FINAS NY INC - 167 Avenue A, 713.4 ft
17. GREAT CATERERS LLC - 208 1st Avenue, 753.23 ft
18. SAO MAI VIETNAMESE CUISINE INC - 203 1st Avenue, 787.04 ft
19. JOSELUIS CORP - 186 Avenue, 811.74 ft
20. KITCHEN 192 INC - 192 1st Avenue, 815.72 ft
21. TRAD JAPAN CORPORATION - 351 East 14th Street, 824.74 ft
22. ELSAYED III CORP - 293 East 10th Street, 824.99 ft
23. SARITAS MACARONI & CHEESE EV LLC - 197 1st Avenue, 866.32 ft
24. HAILE BISTRO INC - 182 Avenue B, 908.98 ft
25. SAHARA EAST RESTAURANT CORP - 184 1st Avenue, 911.8 ft
26. KHILADI LLC - 175 Avenue B, 921.23 ft
27. COOPER CAFE LLC - 5 Stuyvesant Oval, 924.26 ft
28. CHOKDEE NYC INC - 349 East 12th Street, 942.52 ft
29. DST RUSSIAN & TURKISH BATHS INC - 268 East 10th Street, 943.13 ft
30. EAST RIVER RESTAURANT GROUP LTD - 174 Avenue B, Store 1, 955.63 ft
31. AVOA LLC - 174 1st Avenue, 993.19 ft
32. 2ND LHASA FAST FOOD INC - 177 1st Avenue, 1,021.66 ft
33. MONONOKE INC -164 1st Avenue, 1,037.07 ft
34. MOMOFUKU 171 FIRST AVENUE LLC - 171 1st Avenue, 1,039.24 ft
35. HARRY & STEVE INC - 275 1st Avenue, 1,071.68 ft
36. MUGSY'S RESTAURANT GROUP LLC - 435 East 9th Street, 1,132.04 ft
37. WORLD IS A QUICHE LLC - 163 1st Avenue, 1,136.92 ft
38. SODA CLUB NYC LLC - 155 Avenue B, 1,154.91 ft
39. FADED RAINBOW LLC - 430 East 9th Street, 1,154 ft







NYAV Crew Corp
17 Marfo Ln
CENTEREACH, NY 11720 US
(347) 446-3990
mattd@nyavcrew.com
www.nyavcrew.com

Invoice 1523

BILL TO

Ryan Adams
210 Avenue A
501 E 13th Street
New York, NY 10009
United States

DATE
11/13/2019

PLEASE PAY
\$7,087.52

DUE DATE
12/01/2019

ACTIVITY

	QTY	RATE	AMOUNT
Sound Reinforcement			
12 JBL Control 25 Series Compact 2-Way 100V/70V/8-Ohm Surface Mount Loudspeaker	1	3,644.11	3,644.11T
1 JBL 2 zone x 120W Amplifier, Fanless, 70/100V, 1U Half-Rack			
1 JBL 1 zone x 120W Amplifier, Fanless, 70/100V, 1U Half-Rack			
1 18/2 Stranded Speaker Cable Pull Box 1000' White Plenum			
1 Multi Zone Mixer w/Dual Line Level Input			
Miscellaneous			
Tools and Materials	1	300.00	300.00
(1) Custom Cut / Run / Connected XLR Cable Est.- 75' Black or Brown			
Labor			
Commercial installation service	1	2,820.00	2,820.00

Updated to reflect upgrade in JBL speakers.
11/8/2019
MD

SUBTOTAL 6,764.11
TAX (8.875%) 323.41
TOTAL 7,087.52

Updated per site survey
11/11/18
CG

TOTAL DUE **\$7,087.52**

Updated to reflect additional XLR Run from location across to bar, to new rack mixer @ Amp location.
11/13/2019
MD

THANK YOU.

Keltic Woodwork & Construction Management

12 Helen Street

Invoice

Date	Invoice #
2/29/2020	476

Bill To
Percys 215 Ave. A NY, NY

P.O. No.	Terms	Project

Description	Amount
Renovation of Percy's Tavern - 215 Ave. A , NY, NY Original Contract Amount	101,160.00
<p>NOTE: Extra Work completed will be billed on a separate invoice. This invoice is just for the original contract amount.</p>	

Total	\$101,160.00
Payments/Credits	-\$60,000.00
Balance Due	\$41,160.00

Phone #	Fax #
(201) 853-9622	(201) 853-9157

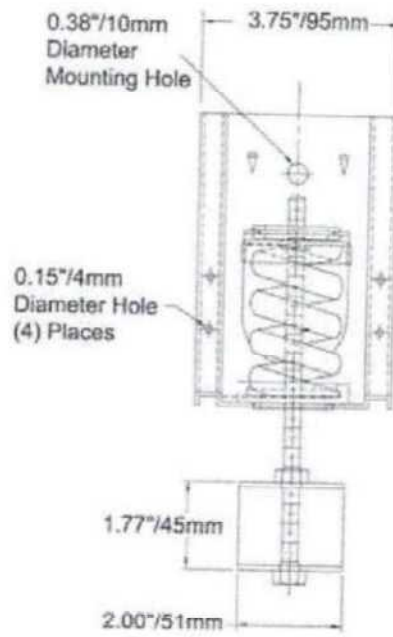
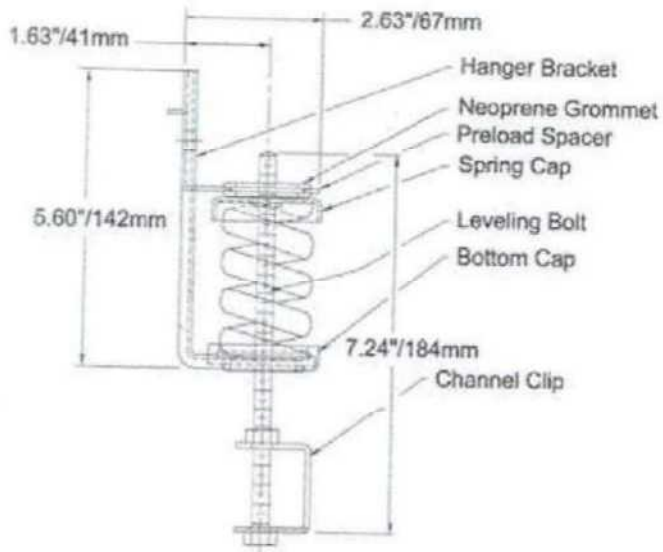

Need a quote? [Click Here](#) to access local contact information

© Kinetics Noise Control, Inc. • P.O. Box 655, Dublin, OH 43017 • Toll Free: 1-877-457-2695 • Fax: 614-889-0540

[Home](#) [Contact](#) [Privacy Statement](#) [Top of Page](#)

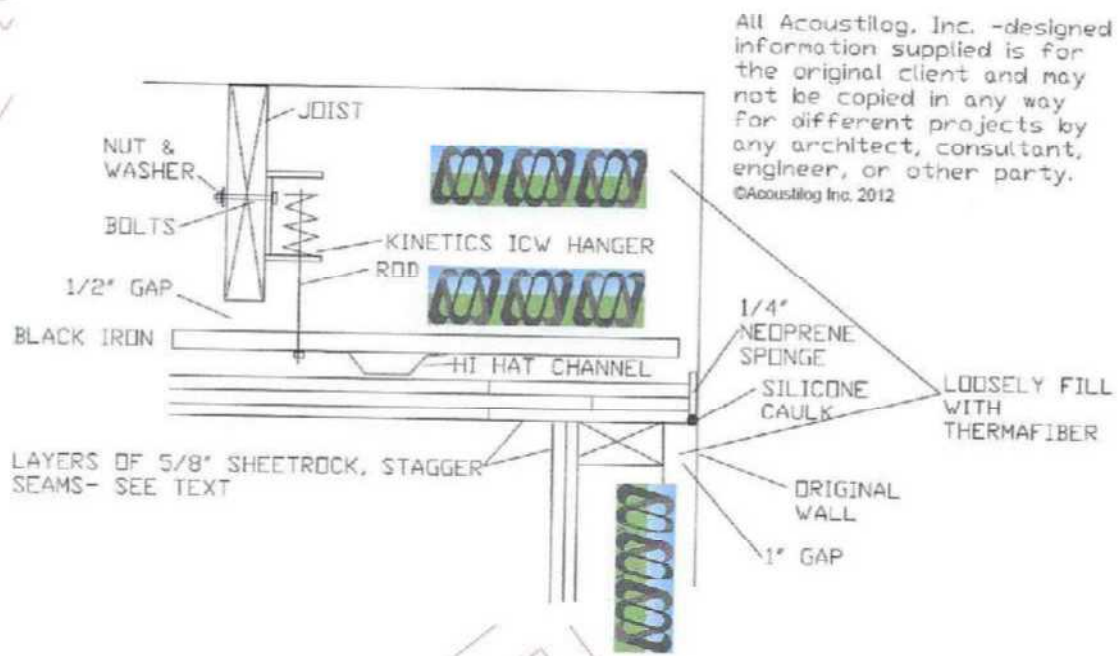

All Acoustilog, Inc. -designed information supplied is for the original client and may not be copied in any way for different projects by any architect, consultant, engineer, or other party.
©Acoustilog Inc. 2012

ACUSTILOG, INC.



Control[®] 1 Pro

Two-Way Professional
Compact Loudspeaker
System

Professional Series

Key Features:

- ▶ 150 Watts Continuous Power Handling
- ▶ Professional Drivers and Crossover Network
- ▶ Included Mounting Bracket
- ▶ Transparent and Faithful Sonic Performance
- ▶ Magnetically Shielded Transducers
- ▶ SonicGuard™ Overload Protection
- ▶ Available in Black or White Finishes

Applications:

Representing the next-generation in professional high-performance, compact loudspeaker systems, the Control[®] 1 Pro builds on its proud heritage while incorporating the latest innovations in JBL Professional loudspeaker systems design. Featuring proven JBL transducer technologies, the Control 1 Pro is perfect for a wide variety of critical near-field audio applications.

With independent, monitor-grade high and low frequency drivers, the Control 1 Pro's professional crossover network provides steep slopes for exceptional sonic performance and incorporates full-range SonicGuard™ overload protection into the design ensuring network and transducer protection from excessive power surges from the amplifier.

The Control 1 Pro's rugged and durable molded enclosure houses magnetically shielded transducers making it ideal for use with video and computer monitors or other magnetically sensitive equipment. Moreover, the Control 1 Pro's compact design makes it ideal for audio-visual applications, computer workstations, recording and broadcast studios, mobile audio-video control rooms and foreground and background music.

The Control 1 Pro can easily be mounted against a wall or other flat surface with the enclosed brackets or simply used as a bookshelf speaker.

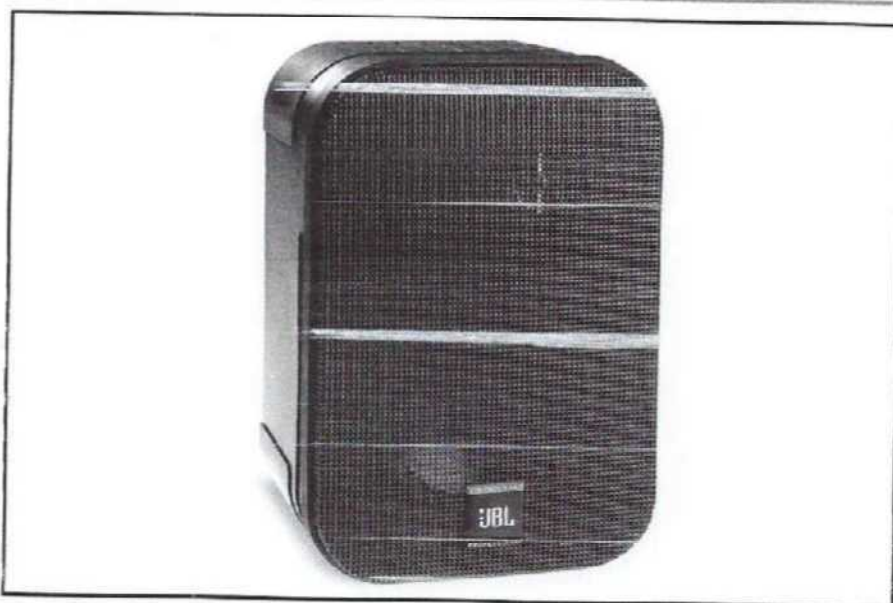

Specifications:

System:	
Frequency Range (-10 dB):	80 Hz - 20 kHz
Frequency Response (+/- 3 dB):	100 Hz - 18 kHz
Power Capacity ¹ :	150 W
Sensitivity ² :	87 dB SPL, 1 W 1 m (3.3 ft)
Maximum SPL ³ :	108 dB continuous, 114 dB peak
Directivity Factor (Q) ³ :	6.0
Directivity Index (DI):	7.8 dB
Nominal Impedance:	4 ohms
Crossover Frequency:	4.2 kHz
Overload Protection:	Full-range SonicGuard™ power limiting to protect network and transducers
Transducers:	
LF Driver:	135 mm (5.25 in) low frequency loudspeaker
HF Driver:	19 mm (.75 in) polycarbonate dome tweeter
Input Connectors:	Spring-loaded terminals
Enclosure:	
Enclosure Material:	Polypropylene Structural Foam
Finish:	Black (C1Pro) or White (C1Pro-WH)
Dimensions:	235 mm x 159 mm x 143 mm (9.3 in x 6.3 in x 5.6 in)
Net Weight (each):	1.8 kg (4 lb)
Shipping Weight (pair):	4.6 kg (10 lb)
Included Accessories:	Mounting Bracket Assembly

¹IEC Standard, full bandwidth, pink noise, with 5 dB crest factor, 2 hour duration.

²Average 1 kHz to 10 kHz

³Calculated based on power rating and sensitivity, exclusive of power compression.

JBL continually engages in research related to product improvement. Some materials, production methods and design refinements are introduced into existing products without notice as a routine expression of that philosophy. For this reason, any current JBL product may differ in some respect from its published description, but will always equal or exceed the original design specifications unless otherwise stated.

► Control 1 Pro Two-Way Professional Compact Loudspeaker

Beamwidth:

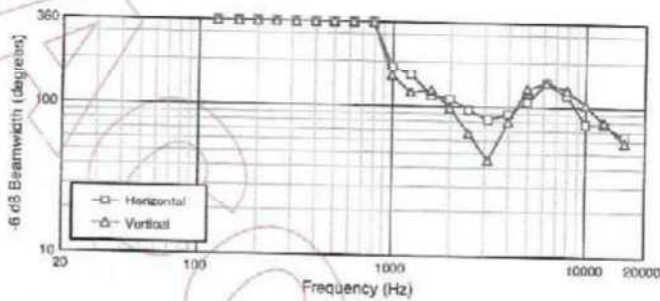

Directivity Index:

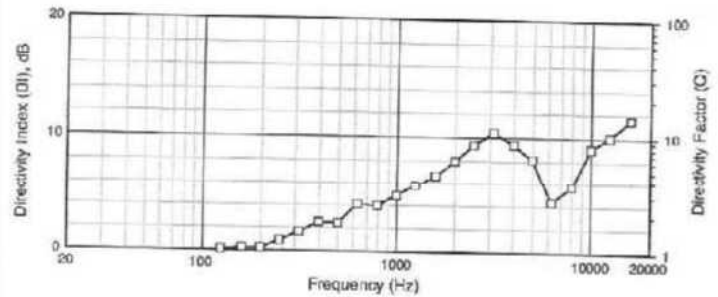

Frequency Response:

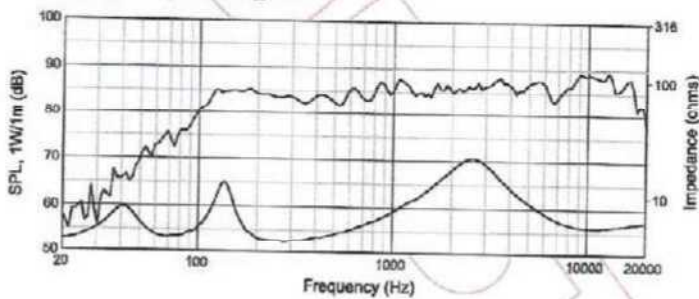

Horizontal Off-Axis Frequency Response:

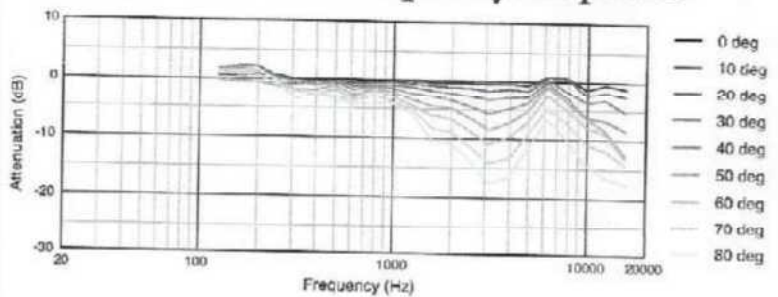

Dimensions:

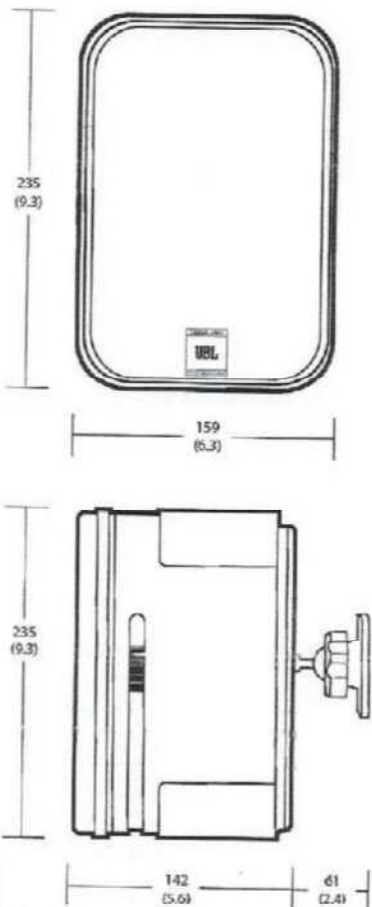

Dimensions in mm (in)

Mounting Bracket:

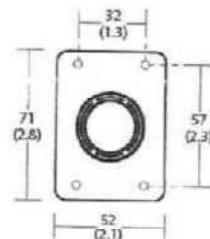
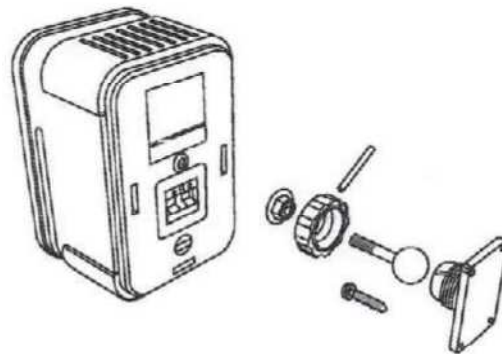

JBL Professional
8500 Balboa Boulevard, P.O. Box 2200
Northridge, California 91329 U.S.A.

© Copyright 2014 JBL Professional
www.jblpro.com

SS C1P
CRP
03/14

ACOUSTILOG

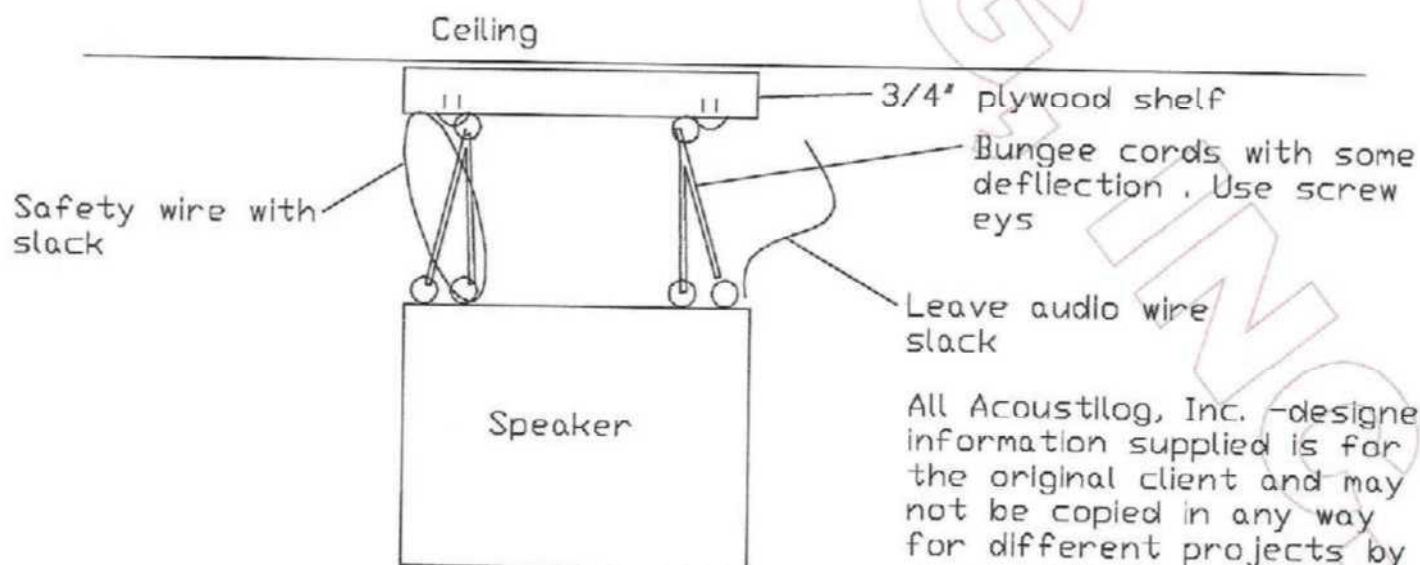

All Acoustilog, Inc. -designed information supplied is for the original client and may not be copied in any way for different projects by any architect, consultant, engineer, or other party.

©Acoustilog Inc. 2010

ACOUSTILOG

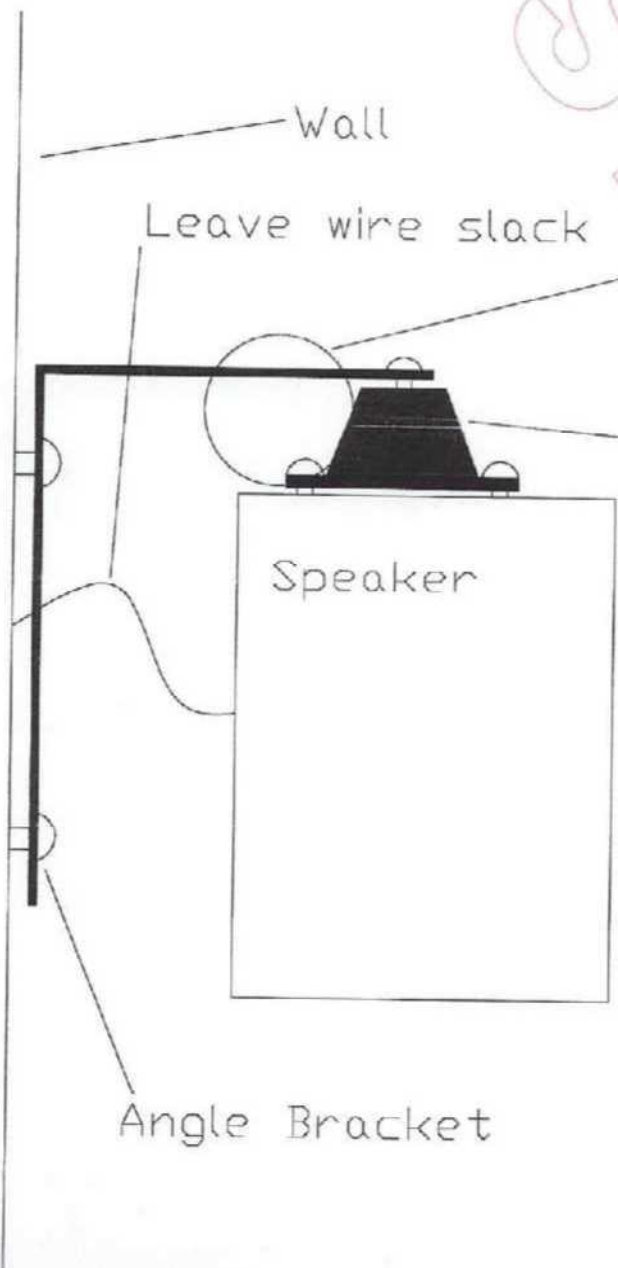

Safety wire with slack- This is necessary because the isolators are normally used under, not over, the device they are holding.

Grainger 4C875 Vibration Isolator - Use 1 for small speakers. Find exact center of gravity so speaker hangs at desired angle.

All Acoustilog, Inc. -designed information supplied is for the original client and may not be copied in any way for different projects by any architect, consultant, engineer, or other party.

©Acoustilog Inc. 2013

All Acoustilog, Inc. -designed information supplied is for the original client and may not be copied in any way for different projects by any architect, consultant, engineer, or other party.

©Acoustilog Inc. 2013

ACOUSTILOG SERIES-PARALLEL HOOKUP

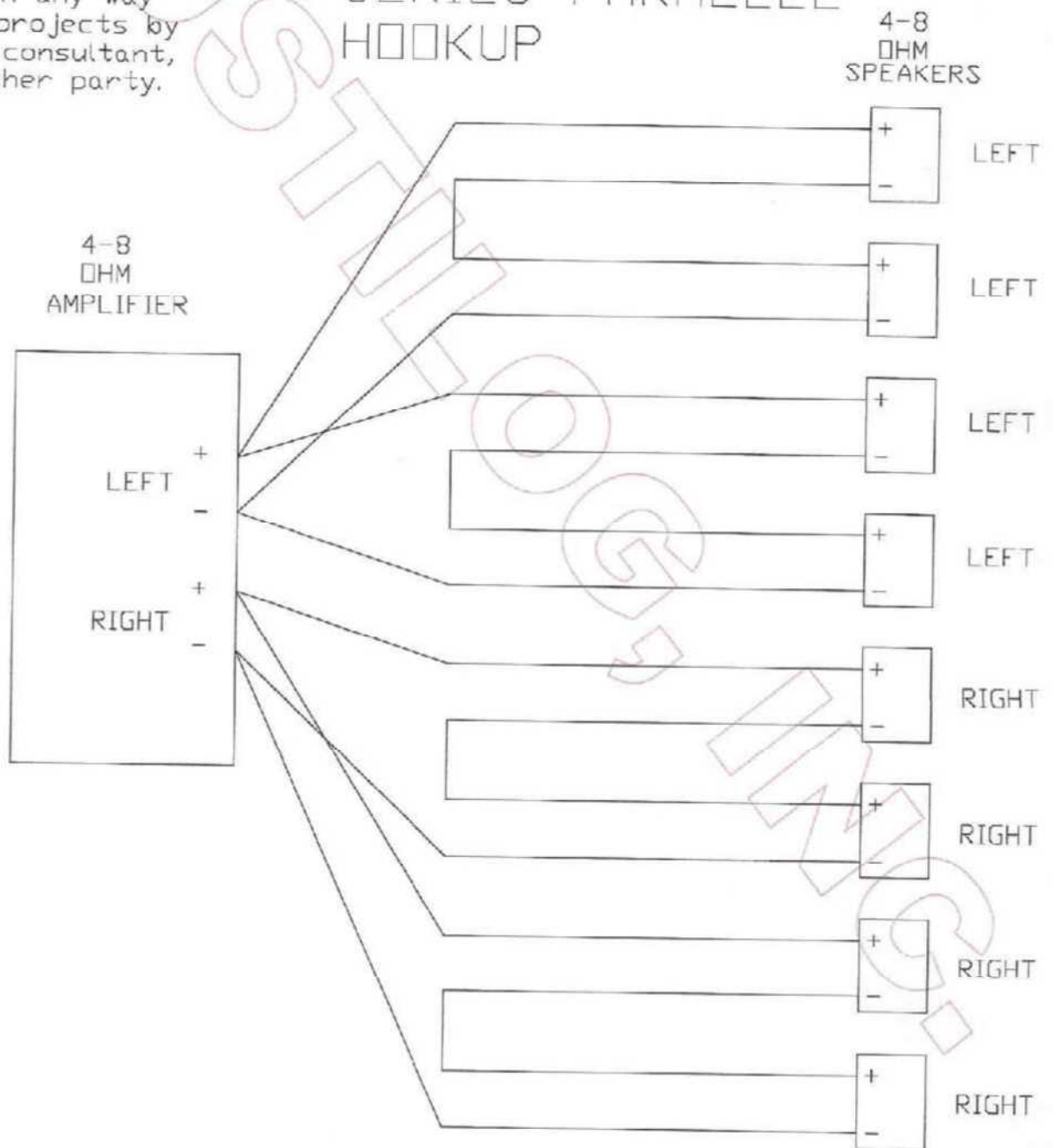

Vibration Isolation Pads

Provide simple-to-use relief from high-frequency vibration such as transformer and motor hum. Protection in isolating 3600 and 1750 RPM pumps and refrigeration compressors. Also used under machines to provide friction and eliminate the need for bolting.

NEOPRENE

2 x 2" modules are easy to cut to size with a box cutter, scissors, or shears. Self-gasketing waffle design helps contain spills and improves suction and grip. Load pads up to 50 lbs. per square inch or 200 lbs. per 2 x 2" square.

NEOPRENE AND STEEL

For concentrated loads such as heavy machines with small legs or formed sheet metal legs without a bottom surface.

Type A

Has a cemented steel plate sandwiched between a bottom super waffle pad and top 1/4" friction pad. No bolting required.

Type B

Replaces the top friction pad with a 3/4" dia. center hole for bolting. Includes 3/4" neoprene isolation washer cemented to a steel washer.

NEOPRENE AND CORK

Two honeycombed neoprene sheets are adhered to a dense, granulated cork core. Pre-cut sizes require no table saw, bolting, or cementing.

Note: Not recommended for outdoor, impact, or heavy-duty situations.



18 x 18" Module Mini Super W

Super W

Neoprene and Steel Type A

Neoprene and Cork

Neoprene and Steel Type B

Description	Nominal Size (In.)	Max. Load (psi)	Pkg. Qty.	Item No.	\$ Each
Neoprene					
Mini Super W	18 x 18 x 3/8	50	1	4C972	46.45
Mini Super W	6 x 6 x 3/8	50	1	5C022	7.14
Mini Super W	4 x 4 x 3/8	50	2	4C973	6.63
Super W	18 x 18 x 3/4	50	1	5XR47	72.45
Neoprene and Steel					
Type A	6 x 4 x 1/4	50	1	4C975	24.81
Type B	6 x 4 x 1	50	1	4C974	24.81
Neoprene and Cork					
—	2 x 2 x 1	50	2	5C027	3.14
—	3 x 3 x 1	50	2	4C976	7.52
—	4 x 4 x 1	50	2	4C977	12.54
—	6 x 6 x 1	50	1	5XR49	13.15
—	12 x 12 x 1	50	1	5C028	47.30
—	18 x 18 x 1	50	1	5C025	97.90

Need help selecting a caster? Check out CasterMatch™ on grainger.com





NYAV Crew Corp
17 Marfo Ln
CENTEREACH, NY 11720 US
(347) 446-3990
mattd@nyavcrew.com
www.nyavcrew.com

Invoice 1523

BILL TO

Ryan Adams
210 Avenue A
501 E 13th Street
New York, NY 10009
United States

DATE
11/13/2019

PLEASE PAY
\$7,087.52

DUE DATE
12/01/2019

ACTIVITY

	QTY	RATE	AMOUNT
Sound Reinforcement			
12 JBL Control 25 Series Compact 2-Way 100V/70V/8-Ohm Surface Mount Loudspeaker	1	3,644.11	3,644.11T
1 JBL 2 zone x 120W Amplifier, Fanless, 70/100V, 1U Half-Rack			
1 JBL 1 zone x 120W Amplifier, Fanless, 70/100V, 1U Half-Rack			
1 18/2 Stranded Speaker Cable Pull Box 1000' White Plenum			
1 Multi Zone Mixer w/Dual Line Level Input			
Miscellaneous			
Tools and Materials	1	300.00	300.00
(1) Custom Cut / Run / Connected XLR Cable Est.- 75' Black or Brown			
Labor			
Commercial installation service	1	2,820.00	2,820.00
Updated to reflect upgrade in JBL speakers. 11/8/2019 MD			
		SUBTOTAL	6,764.11
		TAX (8.875%)	323.41
		TOTAL	7,087.52
Updated per site survey 11/11/18 CG			
		TOTAL DUE	\$7,087.52
Updated to reflect additional XLR Run from location across to bar, to new rack mixer @ Amp location. 11/13/2019 MD			

THANK YOU.

Keltic Woodwork & Construction Management

12 Helen Street

Invoice

Date	Invoice #
2/29/2020	476

Bill To
Percys 215 Ave. A NY, NY

P.O. No.	Terms	Project

Description	Amount
Renovation of Percy's Tavern - 215 Ave. A , NY, NY Original Contract Amount	101,160.00
<p>NOTE: Extra Work completed will be billed on a separate invoice. This invoice is just for the original contract amount.</p>	

Total	\$101,160.00
Payments/Credits	-\$60,000.00
Balance Due	\$41,160.00

Phone #	Fax #
(201) 853-9622	(201) 853-9157

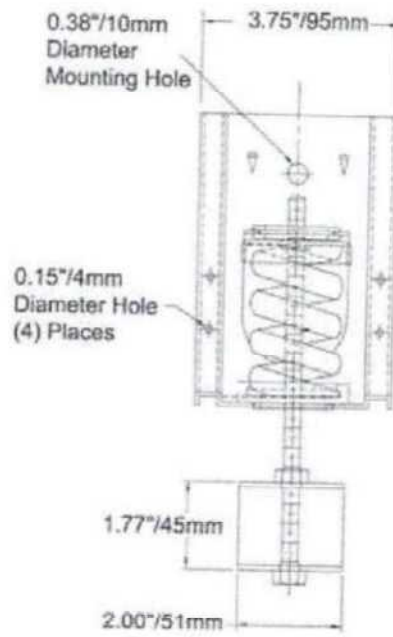
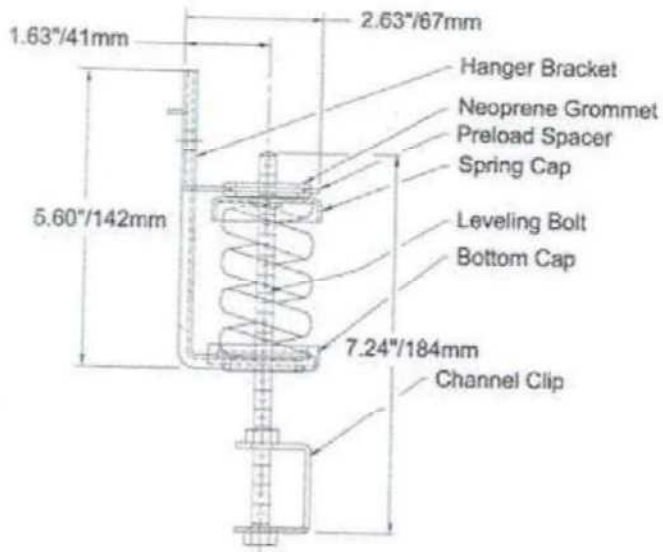

Need a quote? [Click Here](#) to access local contact information.

© Kinetics Noise Control, Inc. • P.O. Box 655, Dublin, OH 43017 • Toll Free: 1-877-457-2695 • Fax: 614-889-0540

[Home](#) [Contact](#) [Privacy Statement](#) [Top of Page](#)

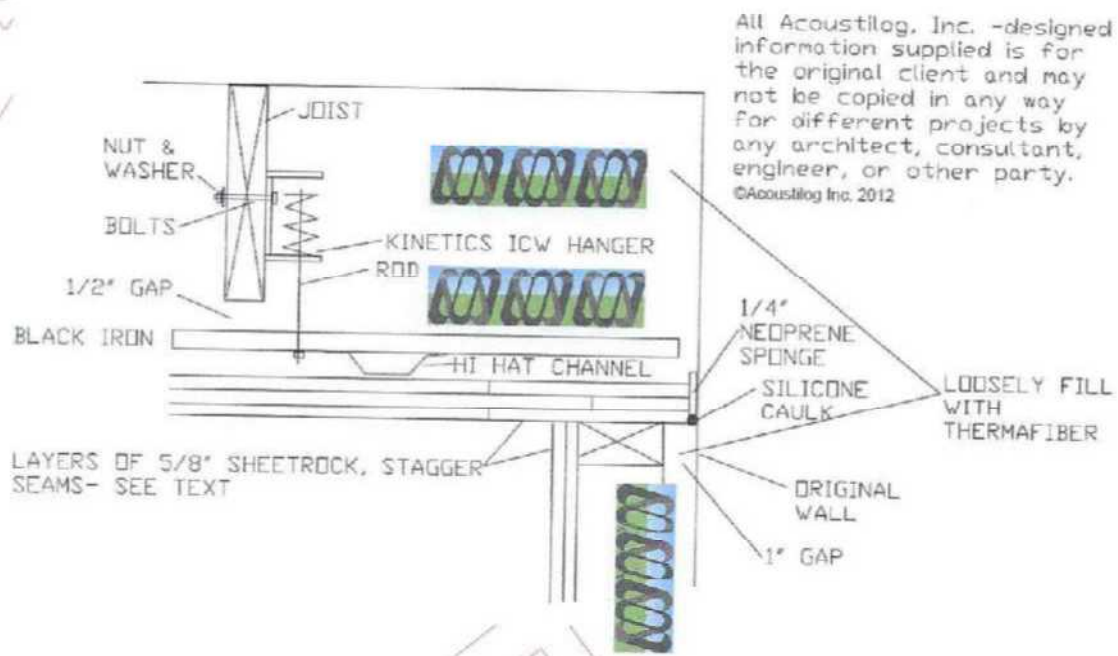

All Acoustilog, Inc. -designed information supplied is for the original client and may not be copied in any way for different projects by any architect, consultant, engineer, or other party.
©Acoustilog Inc. 2012

ACUSTILOG, INC.



Control[®] 1 Pro

Two-Way Professional
Compact Loudspeaker
System

Professional Series

Key Features:

- ▶ 150 Watts Continuous Power Handling
- ▶ Professional Drivers and Crossover Network
- ▶ Included Mounting Bracket
- ▶ Transparent and Faithful Sonic Performance
- ▶ Magnetically Shielded Transducers
- ▶ SonicGuard™ Overload Protection
- ▶ Available in Black or White Finishes

Applications:

Representing the next-generation in professional high-performance, compact loudspeaker systems, the Control[®] 1 Pro builds on its proud heritage while incorporating the latest innovations in JBL Professional loudspeaker systems design.

Featuring proven JBL transducer technologies, the Control 1 Pro is perfect for a wide variety of critical near-field audio applications.

With independent, monitor-grade high and low frequency drivers, the Control 1 Pro's professional crossover network provides steep slopes for exceptional sonic performance and incorporates full-range SonicGuard™ overload protection into the design ensuring network and transducer protection from excessive power surges from the amplifier.

The Control 1 Pro's rugged and durable molded enclosure houses magnetically shielded transducers making it ideal for use with video and computer monitors or other magnetically sensitive equipment. Moreover, the Control 1 Pro's compact design makes it ideal for audio-visual applications, computer workstations, recording and broadcast studios, mobile audio-video control rooms and foreground and background music.

The Control 1 Pro can easily be mounted against a wall or other flat surface with the enclosed brackets or simply used as a bookshelf speaker.



Specifications:

System:

Frequency Range (-10 dB):	80 Hz - 20 kHz
Frequency Response (+/- 3 dB):	100 Hz - 18 kHz
Power Capacity ¹ :	150 W
Sensitivity ² :	87 dB SPL, 1 W 1 m (3.3 ft)
Maximum SPL ³ :	108 dB continuous, 114 dB peak
Directivity Factor (Q) ² :	6.0
Directivity Index (DI):	7.8 dB
Nominal Impedance:	4 ohms
Crossover Frequency:	4.2 kHz
Overload Protection:	Full-range SonicGuard™ power limiting to protect network and transducers

Transducers:

LF Driver:	135 mm (5.25 in) low frequency loudspeaker
HF Driver:	19 mm (.75 in) polycarbonate dome tweeter
Input Connectors:	Spring-loaded terminals

Enclosure:

Enclosure Material:	Polypropylene Structural Foam
Finish:	Black (C1Pro) or White (C1Pro-WH)
Dimensions:	235 mm x 159 mm x 143 mm (9.3 in x 6.3 in x 5.6 in)
Net Weight (each):	1.8 kg (4 lb)
Shipping Weight (pair):	4.6 kg (10 lb)
Included Accessories:	Mounting Bracket Assembly

¹IEC Standard, full bandwidth, pink noise, with 5 dB crest factor, 2 hour duration.

²Average 1 kHz to 10 kHz

³Calculated based on power rating and sensitivity, exclusive of power compression.

JBL continually engages in research related to product improvement. Some materials, production methods and design refinements are introduced into existing products without notice as a routine expression of that philosophy. For this reason, any current JBL product may differ in some respect from its published description, but will always equal or exceed the original design specifications unless otherwise stated.

► Control 1 Pro Two-Way Professional Compact Loudspeaker

Beamwidth:

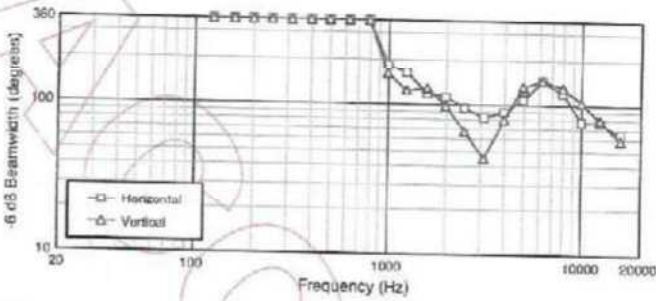

Directivity Index:

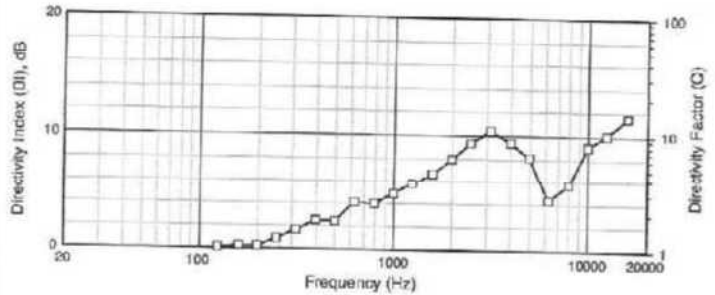

Frequency Response:

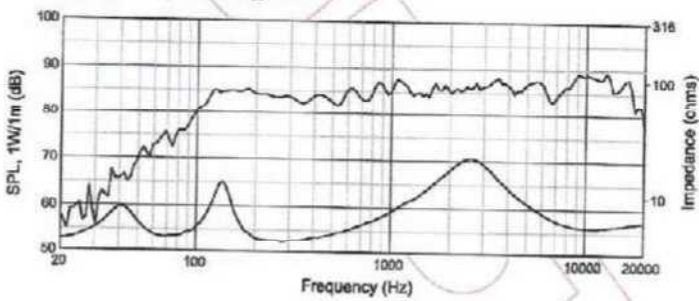

Horizontal Off-Axis Frequency Response:

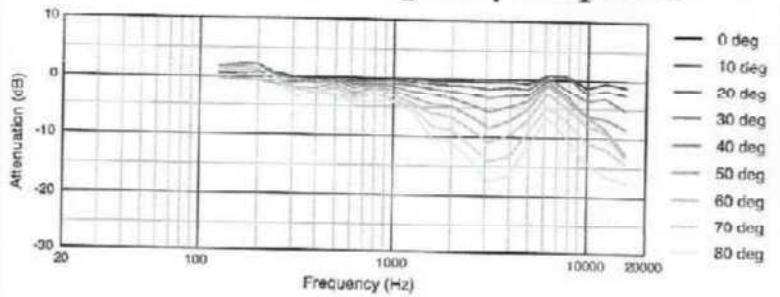

Dimensions:

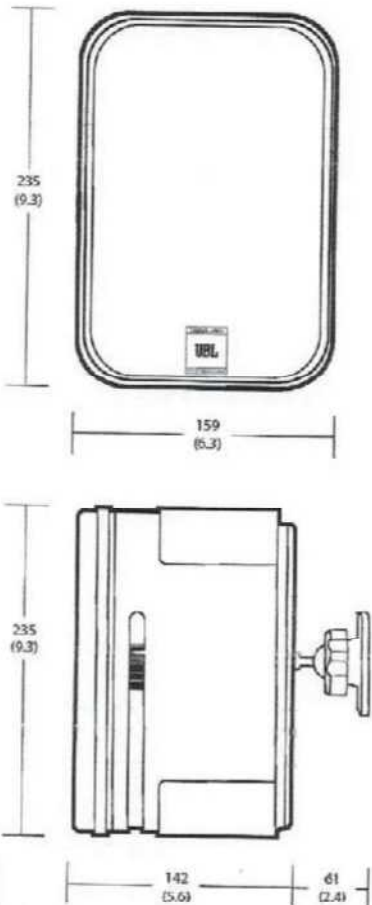

Dimensions in mm (in)

Mounting Bracket:

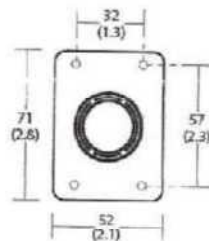
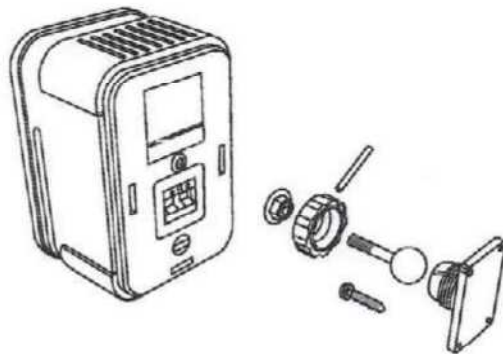

JBL Professional
8500 Balboa Boulevard, P.O. Box 2200
Northridge, California 91329 U.S.A.

© Copyright 2014 JBL Professional
www.jblpro.com

SS C1P
CRP
03/14

ACOUSTILOG

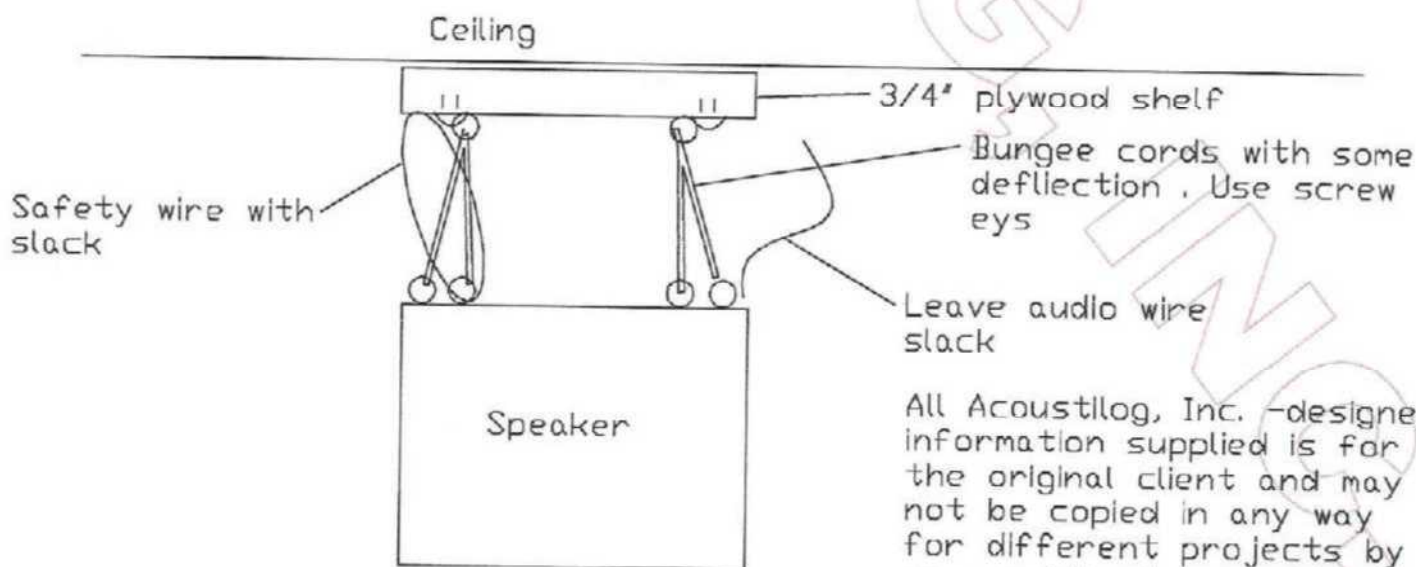

All Acoustilog, Inc. -designed information supplied is for the original client and may not be copied in any way for different projects by any architect, consultant, engineer, or other party.

©Acoustilog Inc. 2010

ACOUSTILOG

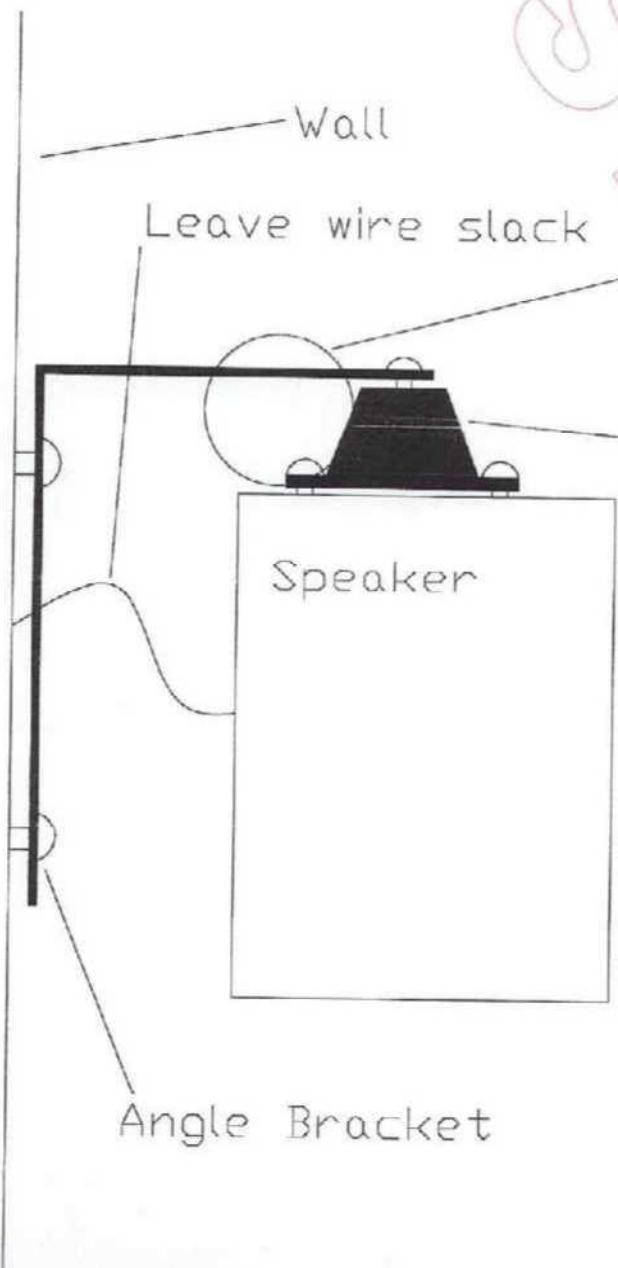

Safety wire with slack- This is necessary because the isolators are normally used under, not over, the device they are holding.

Grainger 4C875 Vibration Isolator - Use 1 for small speakers. Find exact center of gravity so speaker hangs at desired angle.

All Acoustilog, Inc. -designed information supplied is for the original client and may not be copied in any way for different projects by any architect, consultant, engineer, or other party.

All Acoustilog, Inc. -designed information supplied is for the original client and may not be copied in any way for different projects by any architect, consultant, engineer, or other party.

©Acoustilog Inc. 2013

ACOUSTILOG SERIES-PARALLEL HOOKUP

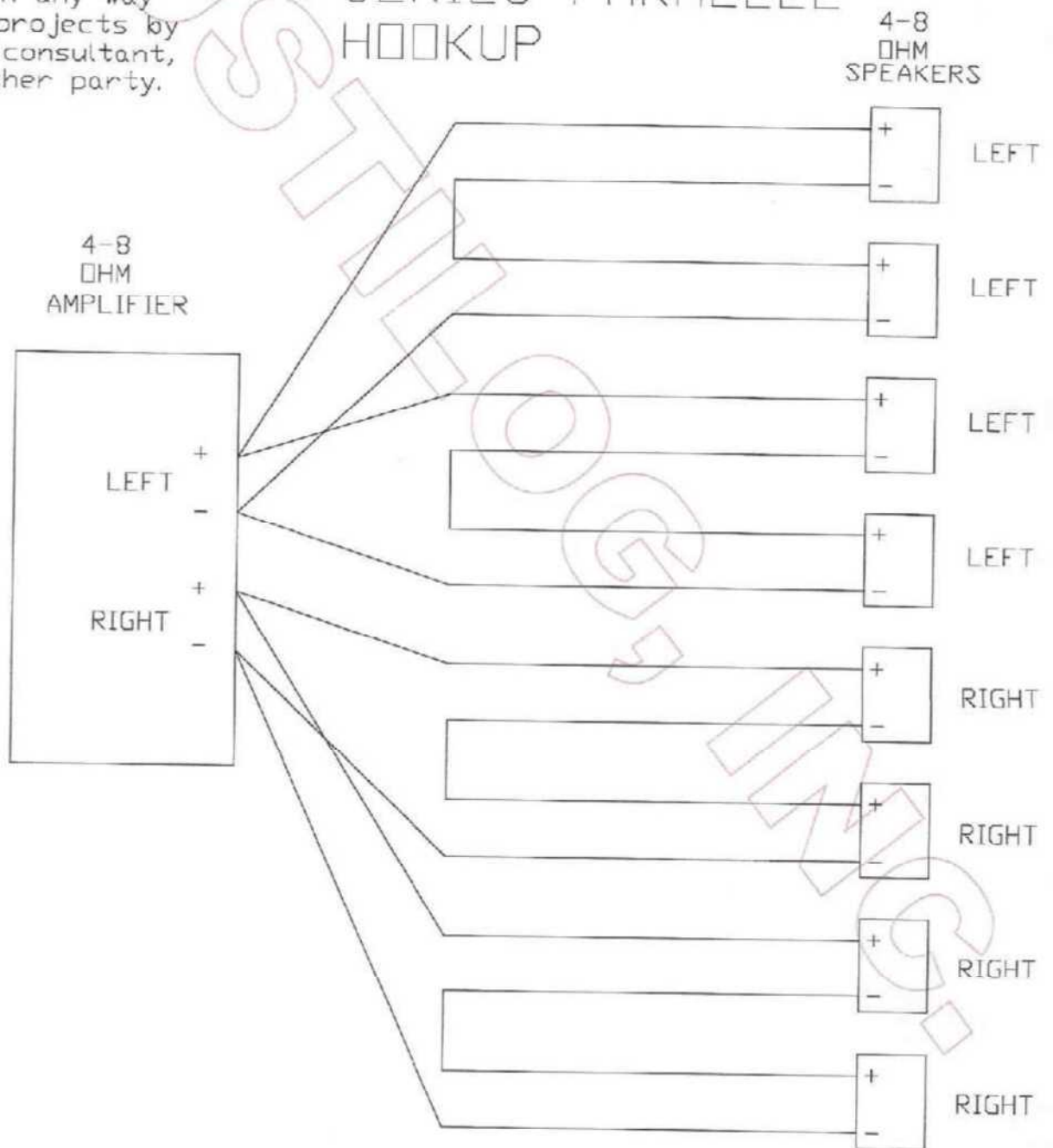

Vibration Isolation Pads

Provide simple-to-use relief from high-frequency vibration such as transformer and motor hum. Protection in isolating 3600 and 1750 RPM pumps and refrigeration compressors. Also used under machines to provide friction and eliminate the need for bolting.

NEOPRENE

2 x 2" modules are easy to cut to size with a box cutter, scissors, or shears. Self-gasketing waffle design helps contain spills and improves suction and grip. Load pads up to 50 lbs. per square inch or 200 lbs. per 2 x 2" square.

NEOPRENE AND STEEL

For concentrated loads such as heavy machines with small legs or formed sheet metal legs without a bottom surface.

Type A

Has a cemented steel plate sandwiched between a bottom super waffle pad and top 1/4" friction pad. No bolting required.

Type B

Replaces the top friction pad with a 3/4" dia. center hole for bolting. Includes 3/4" neoprene isolation washer cemented to a steel washer.

NEOPRENE AND CORK

Two honeycombed neoprene sheets are adhered to a dense, granulated cork core. Pre-cut sizes require no table saw, bolting, or cementing.

Note: Not recommended for outdoor, impact, or heavy-duty situations.



18 x 18" Module Mini Super W

Super W

Neoprene and Steel Type A

Neoprene and Cork

Neoprene and Steel Type B

Description	Nominal Size (In.)	Max. Load (psi)	Pkg. Qty.	Item No.	\$ Each
Neoprene					
Mini Super W	18 x 18 x 3/8	50	1	4C972	46.45
Mini Super W	6 x 6 x 3/8	50	1	5C022	7.14
Mini Super W	4 x 4 x 3/8	50	2	4C973	6.63
Super W	18 x 18 x 3/4	50	1	5XR47	72.45
Neoprene and Steel					
Type A	6 x 4 x 1/4	50	1	4C975	24.81
Type B	6 x 4 x 1	50	1	4C974	24.81
Neoprene and Cork					
—	2 x 2 x 1	50	2	5C027	3.14
—	3 x 3 x 1	50	2	4C976	7.52
—	4 x 4 x 1	50	2	4C977	12.54
—	6 x 6 x 1	50	1	5XR49	13.15
—	12 x 12 x 1	50	1	5C028	47.30
—	18 x 18 x 1	50	1	5C025	97.90

Need help selecting a caster? Check out CasterMatch™ on grainger.com



SLA Violations

JTP Restaurant Corp:

Failure To Provide 30 Days Notice to Community Board for liquor license renewal

Case No: 129215; Due Date: 6/7/2019 Civil Penalty Paid: \$1,000

Sale of a beer to an underage police officer during a sting

Case No: 119532; Due Date: 10/27/2017, Civil Penalty Paid: \$2,500

380 East Ventures LLC

Failure to Adhere to NYDOH Guidance regarding Social Distancing, Inside and Outside Service

Case No. 143691, 6/26/2020 & Case No. 144066, Civil Penalty Paid: \$5,000

Michael Paleudis

From: Michael Paleudis
Sent: Friday, July 29, 2022 2:51 PM
To: megantarter@gmail.com
Subject: 210 Avenue A; Liquor License Application (210/212 Condo Board)

Dear Ms. Tarter:

Our law firm represents Alphabet City Group LLC. Our client has submitted a 30 Day Notice to Manhattan Community Board No. 3 (CB3) because it intends to file an application to the New York State Liquor Authority for a liquor license to be sited at 210 Avenue A. As you may know, this location has been previously licensed. Our client is scheduled to meet with CB3 on August 22, 2022. Please do not hesitate to write or call if your organization has any questions or concerns about this application or would like to meet with our client to discuss the project in advance of its meeting with CB3.

Thank you.

Michael J. Paleudis, Esq.

212.837.8482 (Direct)

212.835.6768 (Main)

mjp@kplawyers.com

www.kplawyers.com



New York | New Jersey | Pennsylvania

Michael Paleudis

From: Michael Paleudis
Sent: Friday, July 29, 2022 2:50 PM
To: 'goodpoet@verizon.net'; 'coamey@housingworks.org'
Subject: 210 Avenue A; Liquor License Application (North Avenue A Neighborhood Association)

Messrs. Goodson and Coamey:

Our law firm represents Alphabet City Group LLC. Our client has submitted a 30 Day Notice to Manhattan Community Board No. 3 (CB3) because it intends to file an application to the New York State Liquor Authority for a liquor license to be sited at 210 Avenue A. As you may know, this location has been previously licensed. Our client is scheduled to meet with CB3 on August 22, 2022. Please do not hesitate to write or call if your organization has any questions or concerns about this application or would like to meet with our client to discuss the project in advance of its meeting with CB3.

Thank you.

Michael J. Paleudis, Esq.

212.837.8482 (Direct)

212.835.6768 (Main)

mjp@kplawyers.com

www.kplawyers.com



New York | New Jersey | Pennsylvania

Michael Paleudis

From: Michael Paleudis
Sent: Friday, July 29, 2022 2:50 PM
To: info@evccnyc.org
Subject: 210 Avenue A; Liquor License Application (East Village Community Coalition)

Ms. Sewell:

Our law firm represents Alphabet City Group LLC. Our client has submitted a 30 Day Notice to Manhattan Community Board No. 3 (CB3) because it intends to file an application to the New York State Liquor Authority for a liquor license to be sited at 210 Avenue A. As you may know, this location has been previously licensed. Our client is scheduled to meet with CB3 on August 22, 2022. Please do not hesitate to write or call if your organization has any questions or concerns about this application or would like to meet with our client to discuss the project in advance of its meeting with CB3.

Thank you.

Michael J. Paleudis, Esq.

212.837.8482 (Direct)

212.835.6768 (Main)

mjp@kplawyers.com

www.kplawyers.com



New York | New Jersey | Pennsylvania