



The City of New York

Manhattan Community Board 1

Monthly Board Meeting

Tuesday, March 26, 2019

6:00 PM

Manhattan Youth

120 Warren Centre Street

(Photo ID is required to enter building)

Anthony Notaro, Jr., Chairperson

Lucian Reynolds, District Manager

Lucy Acevedo, Community Coordinator

Diana Switaj, Director of Planning and Land Use

Ramesh Beharry and Jennifer Maldonado, Consultants

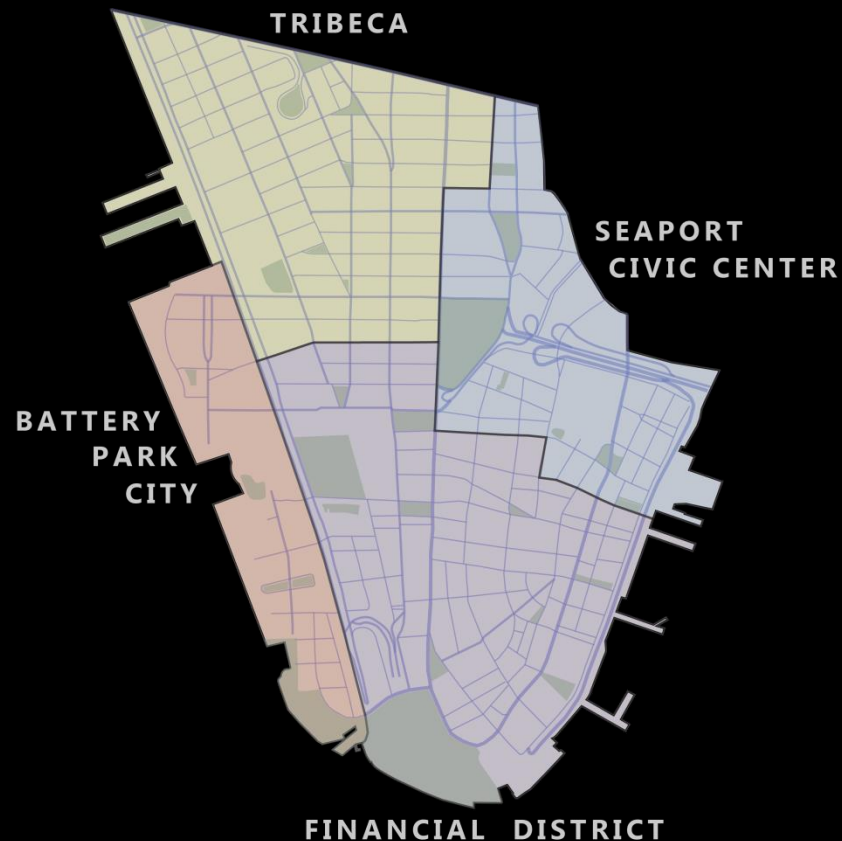

COMMUNITY BOARD 1'S OFFICE CONTACT

Manhattan Community Board 1
1 Centre Street, Room 2202 North
New York, NY 10007
Tel: (212) 669-7970

Website: nyc.gov/mcb1

Email: Man01@cb.nyc.gov



Manhattan Community Board 1

Public Session

Comments by members of the public (6 PM to 7 PM)

(Please limit to 1-2 minutes per speaker to allow everyone to voice their opinions)

Manhattan Community Board 1

Business Session

- Adoption of February 2019 minutes
- District Manager's Report – L. Reynolds
- Chairperson's Report – A. Notaro, Jr.

Manhattan Community Board 1 District Manager's Report



Manhattan Community Board 1 District Manager's Report



White Street Community Plaza

Manhattan Community Board 1 District Manager's Report



White Street Community Plaza



MANHATTAN
COMMUNITY BOARD 1

CHAIRPERSON'S REPORT
MARCH 26, 2019

● Chair Report – *What's Happening*

▫ **Bogardus Plaza Garden construction starts**

▫ **Charter revision**

- What City process are you unhappy with?

- **New dates** – The preliminary report would probably be released in mid April and another set of borough hearings (tentative public hearing dates: **April 30, May 2, May 7, May 9, and May 14**)

- Look at URL <http://www.charter2019.nyc/>

▫ **Rikers Island Closing – Manhattan Detention Complex (MDC)**

- CB1 Leads ULURP – March 25 certification

- April & May Land Use Meetings for May Resolution

▫ **Downtown Little League wins Governor's Island Request for Proposals – 5 year permit**

● Chair Report – *Priorities*

- **Aligning & Tracking Budget Request for Results**
 - Tracking Resolutions versus Results
 - Urban Fellow project will address
 - Budget Task Force or Committee Process
- **Resiliency**
 - New plan for Financial District & Seaport released
 - New meetings planned to update board
 - 4/22 EP Committee
 - Impact on Brooklyn Bridge esplanade project
 - Seaport Advisory Group – New Market site, Howard Hughes Corporation, +Pool, 250 Water St.
- **9/11 Victims Compensation Fund Event**
- **Parliamentary procedure and work at committees**
- **Member vacancies**

Chair Report – *Lower Manhattan Coastal Resiliency 2.0*



● Chair Report – Why I Fight











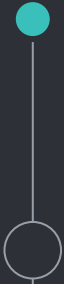

Manhattan Community Board 1 Committee Reports

Executive – A. Notaro, Jr.

- 1) Strategy for future environmental actions – Report
- 2) Member Participation & Parliamentary Procedure – Report
- 3) 2019 Goals and 2018 accomplishments – Report

Manhattan Community Board 1 Committee Reports

Transportation & Street Activity Permits – A. Notaro, Jr.

- 1) Congestion pricing – Resolution
- 2) Street Co-Naming Task Force – Report

Manhattan Community Board 1 Committee Reports

Land Use Zoning & Economic Development – P. Kennell

- 1) 250 Water Street Brownfield Cleanup Program application – Resolution
- 2) Borough Based Jail System Plan & Manhattan Detention Complex – Report
- 3) Supertalls – Report

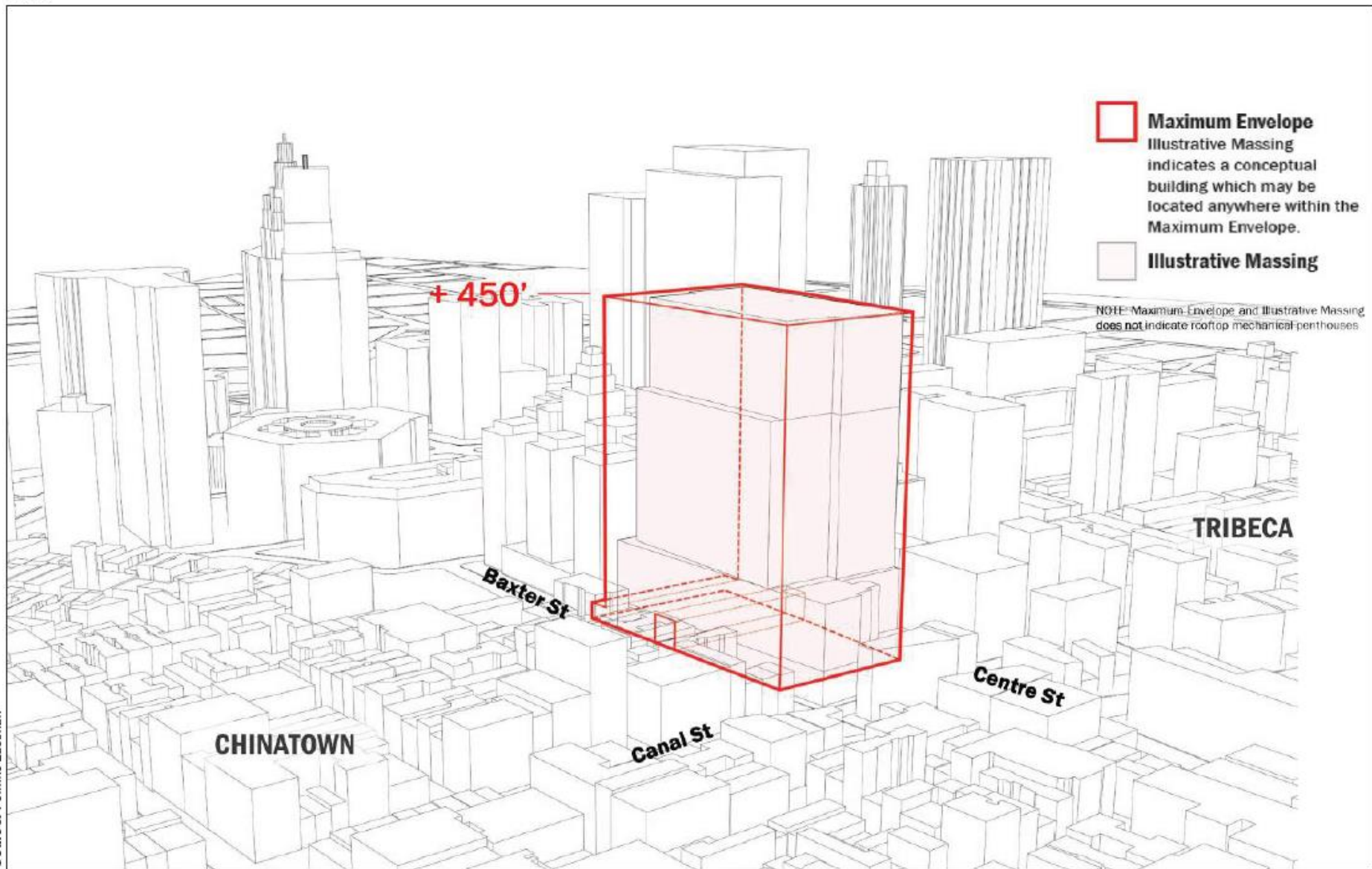

Maximum Envelope
 Illustrative Massing indicates a conceptual building which may be located anywhere within the Maximum Envelope.

Illustrative Massing

NOTE: Maximum Envelope and Illustrative Massing does not indicate rooftop mechanical penthouses

TRIBECA

CHINATOWN

Baxter St

Canal St

Centre St

+ 450'

Manhattan Site - 124-125 White Street
 3D Massing
 Figure S-19



Source: Perkins Eastman

Manhattan Site - 124-125 White Street
Illustrative Street Level Rendering
Figure S-20

Manhattan Community Board 1 Committee Reports

Waterfront, Parks & Cultural – P. Goldstein

- 1) East River Esplanade parking under the FDR Drive current and future use – Resolution
- 2) Hudson River Park – Report
- 3) Governors Island ball fields – Report
- 4) Future of the New Market Building site – Report

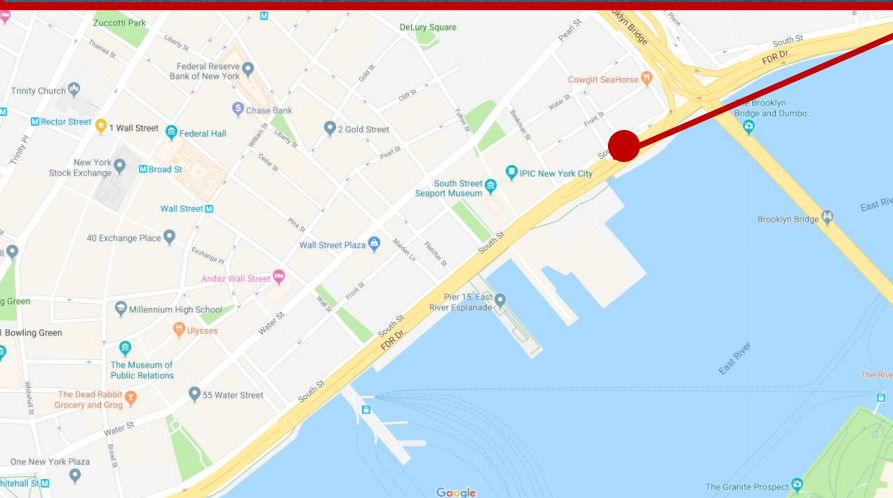
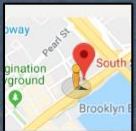

PARKING UNDER THE FDR DRIVE PECK SLIP & SOUTH STREET

**Community Board 1
Pier 26 Update
March 19, 2019**

**Concept
Plan**

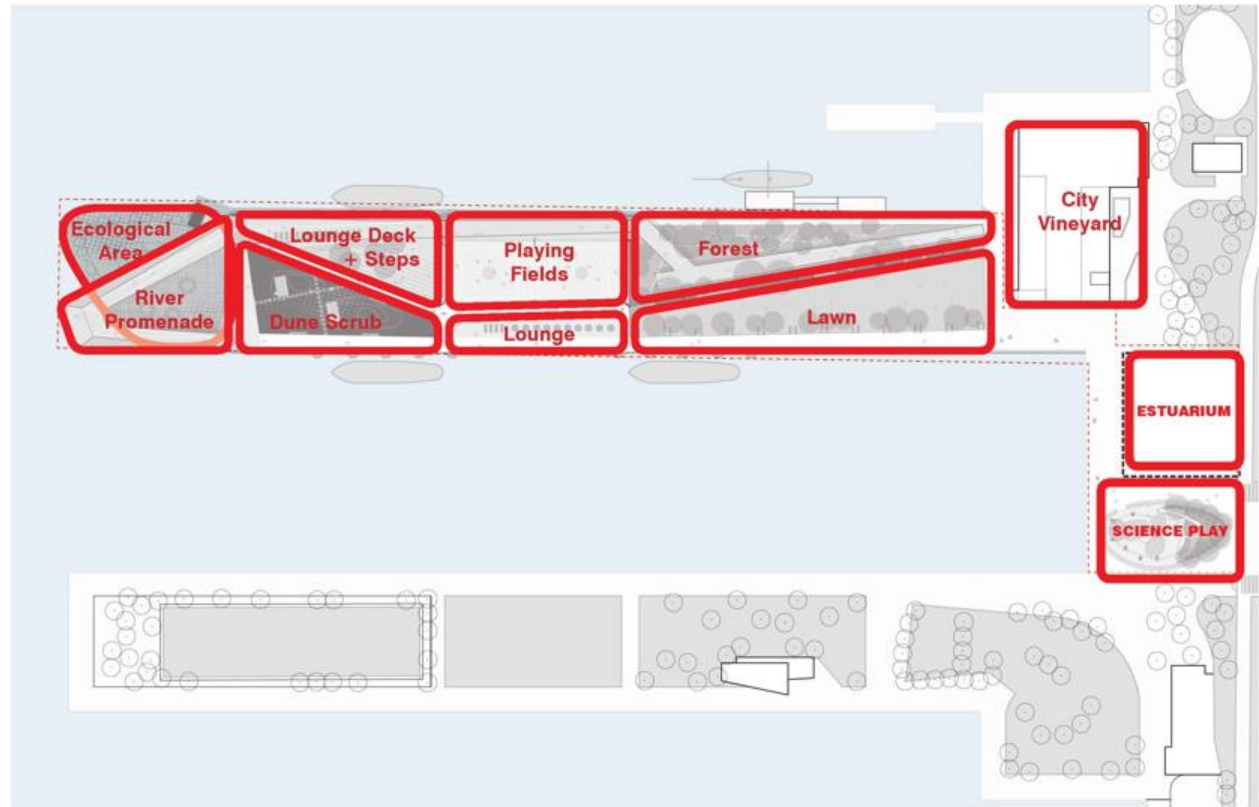

HUDSON RIVER PK

**Ariel
View**





Schedule

Near Term Crane Schedule:

- 3/19 9PM - 9AM First Concrete Panel Placed
- 3/20 9PM - 9AM Second Concrete Panel Placed
- 3/21 9PM - 9AM Third Concrete Panel Placed

Long Term Construction Schedule:

- Spring 2019 Marine work completes
- Spring 2019 Landscape work commences
- Fall 2020 Construction Completion

Manhattan Community Board 1 Committee Reports

Youth & Education – T. Joyce

- 1) Request for additional crossing guards or traffic agents at Chambers Street for IS 289 – Resolution
- 2) Eye to Eye Mentorship Program – Report
- 3) Request for SCA/DOE to acquire the 14th floor of 60 Broad Street for Millennium High School, without adding capacity – Report
- 4) Follow up with DOE/SCA regarding the Safety concerns in the lobby at 81 New Street and finding a new entrance for charter school – Report

Manhattan Community Board 1 Committee Reports

Landmarks & Preservation – R. Byrom

1) 77 White Street, application to replace deteriorated sidewalk vault –
Resolution

2) 105-107 Reade Street, (Block 145, Lot 18) application for restoration and
metal glass rooftop addition to existing 5-story building constructed in 1860-
1861 – Resolution

77 White Street - Proposed

77 White Street – Vault and Sidewalk Replacement

15



Proposed Sidewalk Sections

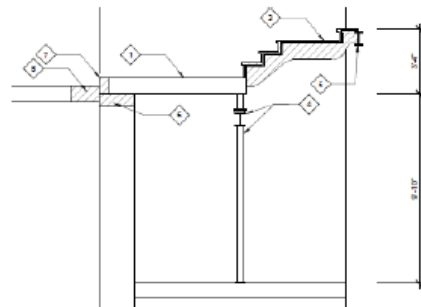

(E) SECTION A

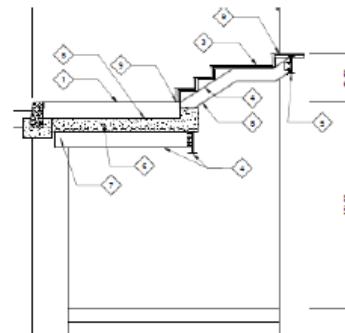

(N) SECTION A

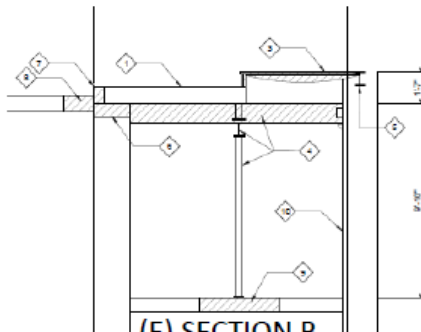

(E) SECTION B

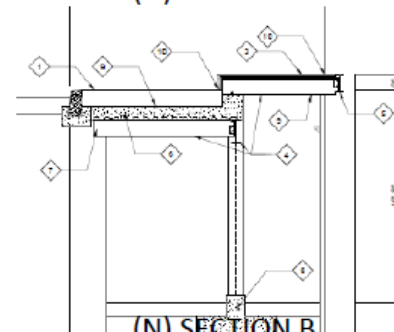

(N) SECTION B

77 White Street - Historic

77 White Street – Vault and Sidewalk Replacement 3



Building Information:

- Year built: 1888
- Multi-Family Residential Building
- Number of floors: 6
- Historic District: Tribeca East Historic District
- Not individually Landmarked



77 White Street - Present

77 White Street – Vault and Sidewalk Replacement 4



Proposed Scope of Work:

- Vault replacement on White Street
- Remove and store salvageable cast iron vault light panels



77 White Street - Interior

77 White Street– Vault and Sidewalk Replacement 6



- Vault steel framing is severely deteriorated



105-107 Reade Street – Existing Conditions

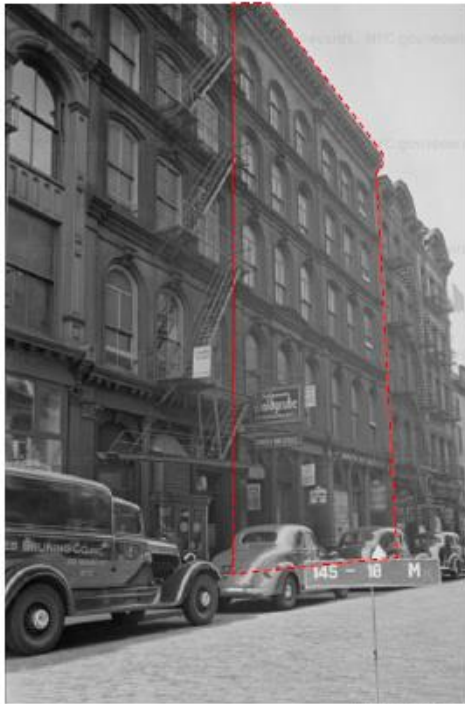

HISTORIC TAX PHOTO,
LOT 18 INDICATED
CIRCA 1940



EXISTING 105 READE ENTRANCE CONDITION



EXISTING 107 READE ENTRANCE CONDITION



EXISTING FACADE & WINDOW CONDITION



EXISTING ROOFTOP BULKHEAD CONDITION



COMMUNITY BOARD 1
105-107 READE STREET_03.14.2019

RESTORATION, STOREFRONTS & ROOFTOP ADDITION

FOGARTY FINGER
architecture | interiors



EXISTING
105 READE STREET

EXISTING
107 READE STREET

105-107 READE STREET

- 5 STORIES
- LOT AREA 3,815 SF
- 4 RESIDENTIAL FLOORS
- 1 COMMERCIAL FLOOR AT STREET LEVEL
- ZONING: C6-3A/R9A
- OWNER: GDS DEVELOPMENT
- BUILT IN 1860-1861
- LOCATED IN THE TRIBECA SOUTH HISTORIC DISTRICT

EXISTING FRONT FACADE

105-107 READE STREET_03.14.2019

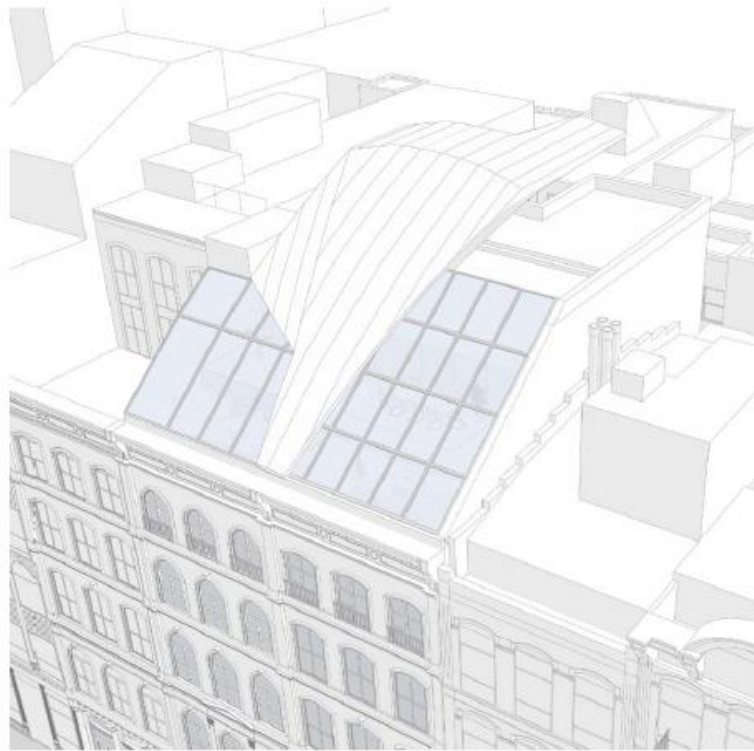

PRIOR LPC APPROVED PROPOSAL ROOF ADDITION

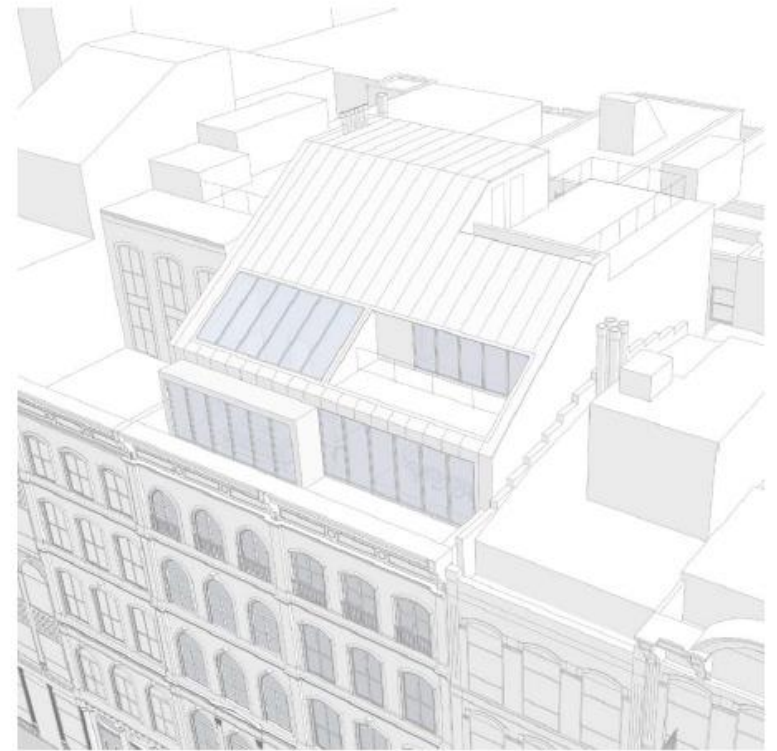

PROPOSED SCHEME ROOF ADDITION

105-107 Reade Street – Visibility from Park

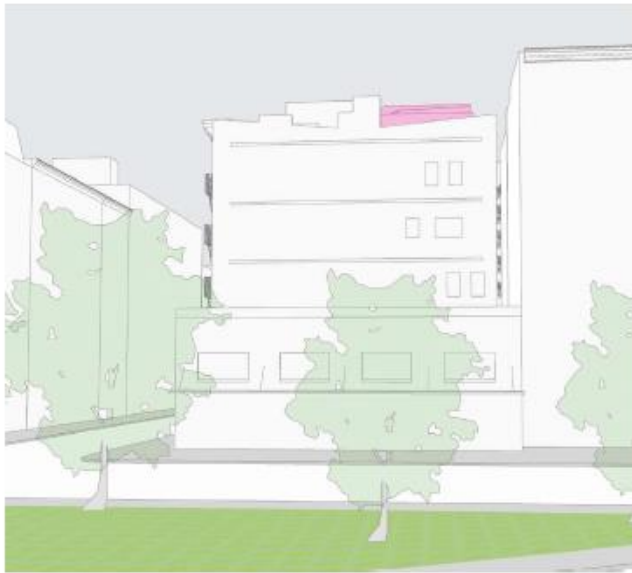

— PRIORITY APPROVED PROPOSAL
VISIBLE AREA FROM SIGHTLINE 3



— PROPOSED SCHEME VISIBLE
AREA FROM SIGHTLINE 3



COMPARISON VIEW 3
105-107 READE STREET_03.14.2019

Manhattan Community Board 1 Committee Reports

Battery Park City – T. Meltzer

- 1) Museum of Jewish Heritage and Upcoming Museum Events – Report
- 2) Ruth Ohman Memorial – Report
- 3) Warren Street Traffic Control Request – Report
- 4) Crosswalks in North Battery Park City – Report
- 5) Allied Universal Report, Update on SPO – Report
- 6) BPCA Report with Security Updates – Report

Manhattan Community Board 1 Committee Reports

Quality of Life & Service Delivery – P. Moore

- 1) Sidewalk Shed and Scaffolding Reform – Report
- 2) 1st Precinct, Sector C Build The Block – Report

1st Precinct Neighborhood Policing

A brief overview and what meetings are like

1ST PRECINCT - NEW SECTORS

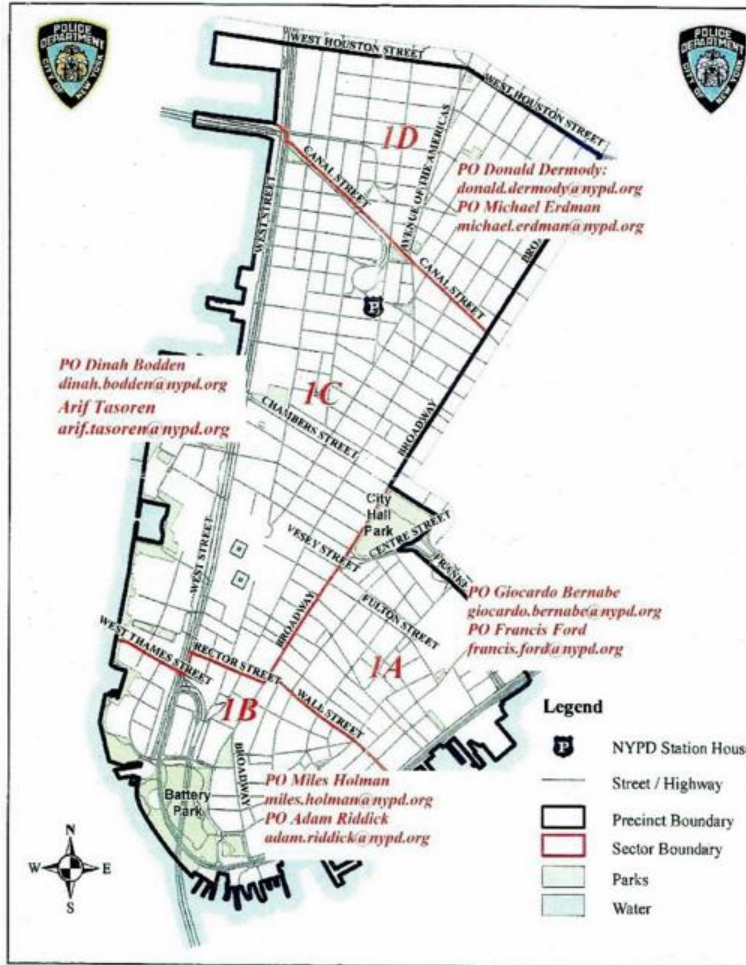

Neighborhood Coordination Officers (NCO's)

- Each sector has two designated NCO's
- NCO's are charged with meeting residents, building managers, area workers & business owners
- Work to become familiar with faces and problems in their sector
- Address sector problems by informing their superiors and coordinating NYPD resources to address those problems; including officers assigned to that sector 24 hrs/day, 7 days/week
- Work with the special units that address reported crimes.
- NCO's do NOT replace calling 911

BUILD THE BLOCK

Neighborhood Policing & Safety Meeting



NYPD
New York City Police Department

**1st PRECINCT
SECTOR C
TRIBECA**

For accommodations regarding any disability, please contact

Lieutenant
Francisco Munoz
at
(212)334-0610

or
FRANCISCO.MUNOZ@nypd.org
at least 72 hours
prior to the event.
(By 2/24/19)



The NYPD officers serving your community invite you to a discussion of the public safety challenges in our neighborhood.

With neighborhood policing, the Neighborhood Coordination Officers (NCOs), and the Steady Sector Officers who work with them, have been given more time and opportunity to collaborate with residents in identifying and solving local quality of life conditions and crime concerns. The same officers are assigned to our community each day, so these officers learn the neighborhood, its challenges and potential, and the people who call it home.

This is a new way of doing business for the NYPD, and we need your help to make it work. We want to hear from a broad range of voices about what it will take to make all the residents of our neighborhood feel safe and secure. Please join us for what we hope will be a lively and productive discussion.

MEETING DATE: Wednesday February 27th, 2019

MEETING TIME: Doors open at 6:00 PM for refreshments
Meeting begins at 6:30 PM

MEETING SITE: Public School 234, Auditorium
292 Greenwich St, New York, NY 10007

SPONSORED BY: Your Neighborhood Coordination Officers
Police Officer Dinah Bodden
Police Officer Arif Tasoren

R.S.V.P.: dinah.bodden@nypd.org

GOAL
**TO IDENTIFY POLICING &
PUBLIC SAFETY NEEDS IN OUR
COMMUNITY.**



FIND YOUR MEETING
BuildTheBlock.nyc



1ST PRECINCT NEIGHBORHOOD POLICING

Sergeant Eugene Cummings

eugene.cummings@nypd.org

SECTOR C

Police Officer Dinah Bodden

dinah.bodden@nypd.org

Police Officer Arif Tasoren

arif.tasoren@nypd.org

Key Points

- It is good to know your NCO's and to attend their Build-the-Block meetings to help identify and resolve neighborhood crime and quality of life issues.
- Attendees seem to appreciate
 - getting explanations about the relevant legal issues,
 - learning what data to collect to help police, and
 - sharing ideas with other people who are or have faced the same problem.
- People who come to this committee with police-related issues should be encouraged to talk to their NCO's.
- 911 should be called as soon as possible for any criminal or emergency issues.

Manhattan Community Board 1 Committee Reports

Environmental Protection – A. Blank

- 1) Clean Air Campaign – Report
- 2) Mayor's Office of Sustainability – Report





SUSTAINABILITY IN NEW YORK CITY

NYC Mayor's Office of
Sustainability



WE WORK IN TEAMS



BUILDINGS &
ENERGY EFFICIENCY



INFRASTRUCTURE
& ENERGY

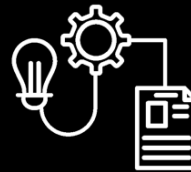

STRATEGIC
INITIATIVES



MARKETING
& ENGAGEMENT

GHG IMPACT OF 2020 CLIMATE ACTIONS

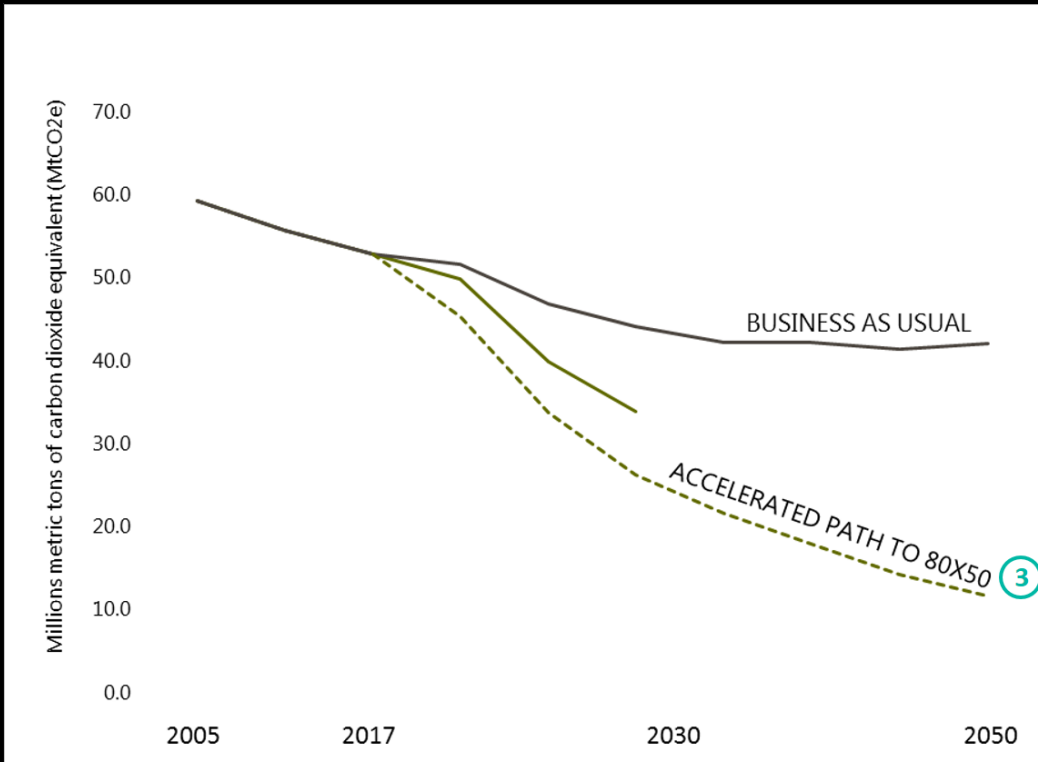

ACCELERATED PATH TO 80X50

- Reaching the City's long-term climate objectives will require persistent effort and constant reevaluation of progress and strategies

Manhattan Community Board 1 Committee Reports

Licensing & Permits – J. Ehrlich

Seaport/Civic Center area

- 1) 89 South Street, application for liquor license for Pier 17 GR Restaurant LLC d/b/a TBD – Resolution

Financial District area

- 1) 65 Broadway, application for liquor license for 74 Parsons Corp d/b/a Pending TBD – Resolution

Manhattan Community Board 1 Committee Reports

Licensing & Permits – J. Ehrlich

Tribeca area

- 1) 241 West Broadway, application for alteration of liquor license for a sidewalk cafe for White Walker LLC d/b/a Frenchette – Resolution
- 2) 385 Broadway, application for liquor license for HC Downtown Inc. d/b/a High Court – Resolution
- 3) 429 Greenwich Street, application for liquor license for Paisley Restaurant LLC d/b/a Paisley – Resolution

Manhattan Community Board 1

Old Business

Manhattan Community Board 1

New Business

Thank you and goodnight