

June 9, 2026  
Public Hearing

The current proposal is:

Preservation Department – Item 8, LPC-26-05686

## **125 East 64th Street – Upper East Side Historic District Borough of Manhattan**

**To testify virtually, please join Zoom**

**Webinar ID:** 165 868 4773

**Passcode:** 126605

By Phone: 646-828-7666 (NY)

833-435-1820 (Toll-free)

833-568-8864 (Toll-free)

**Note:** If you want to testify virtually on an item, join the Zoom webinar at the agenda's "Be Here by" time (about an hour in advance). When the Chair indicates it's time to testify, "raise your hand" via the Zoom app if you want to speak (\*9 on the phone). Those who signed up in advance will be called first.

125 EAST 64<sup>th</sup>

STREET

---

LPC PRESENTATION

5/4/2026

PREPARED BY: ■ **Ronnette Riley** *Architect*





# 125 E 64th STREET

UPPER EAST SIDE HISTORIC DISTRICT

---

Proposed replacement of 64<sup>th</sup> Street  
windows:

2 at ground floor

6 at upper floors

UPPER EAST SIDE HISTORIC DISTRICT

F I F T H

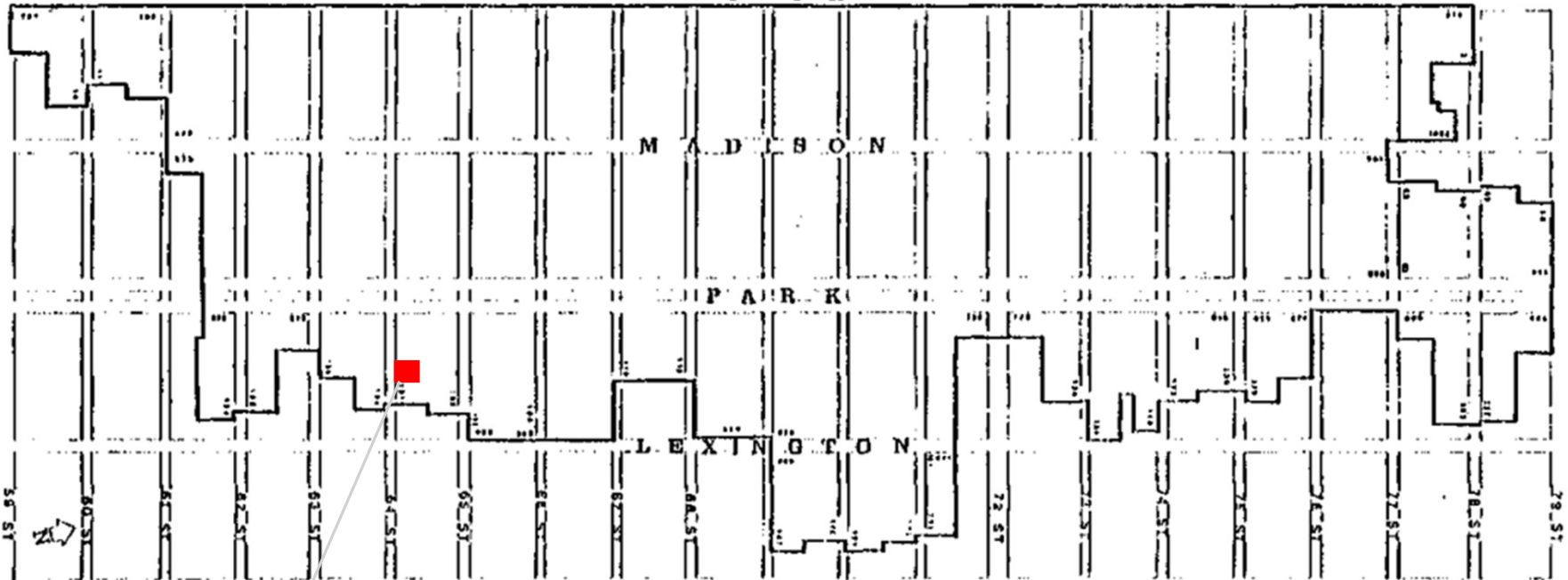

LANDMARKS PRESERVATION COMMISSION

PUBLIC HEARING JUNE 10, 1979

DESIGNATED MAY 10, 1981

125 EAST 64<sup>th</sup>  
STREET

■ Ronnette Riley *Architect*



## Designation Photo:

MAY 19<sup>th</sup> 1981



*Tax Photo 1940's*

■ **Ronnette Riley** *Architect*

TOP FLOORS - 6 EXISTING WINDOWS

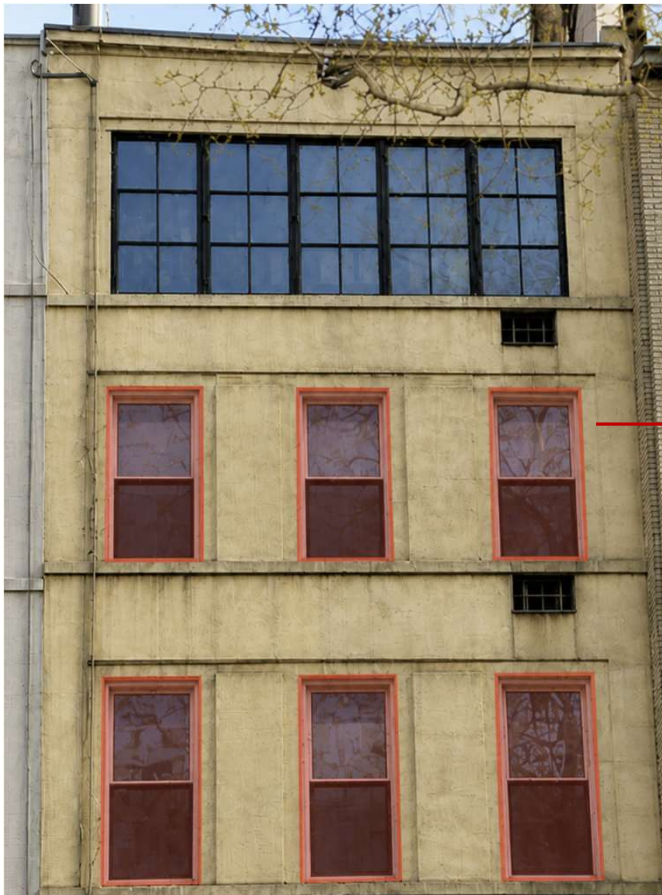

Removals 6

Removals 2

GROUND FLOOR - 2 EXISTING WINDOWS



# FRONT ELEVATIONS

125 EAST 64<sup>th</sup> STREET

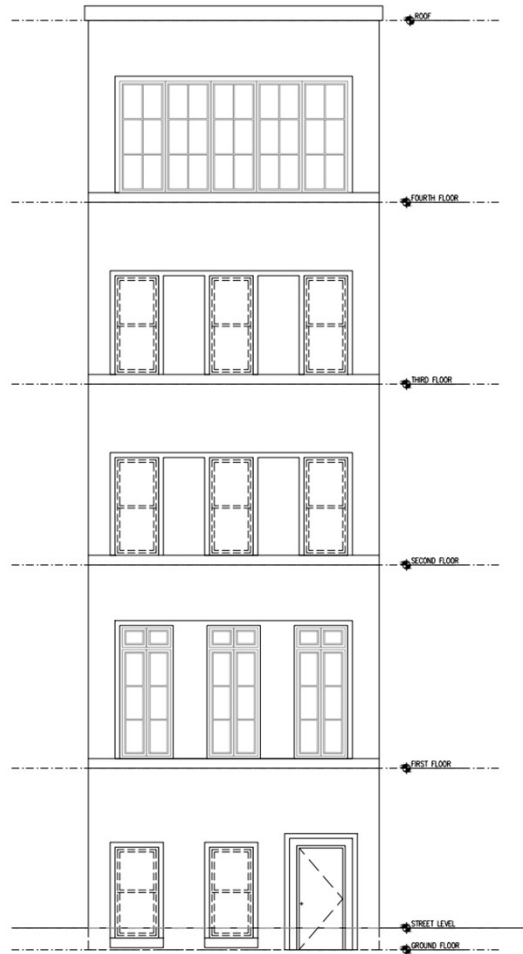

1 DEMOLITION FRONT ELEVATION (WINDOW)  
1/4"=1'-0"

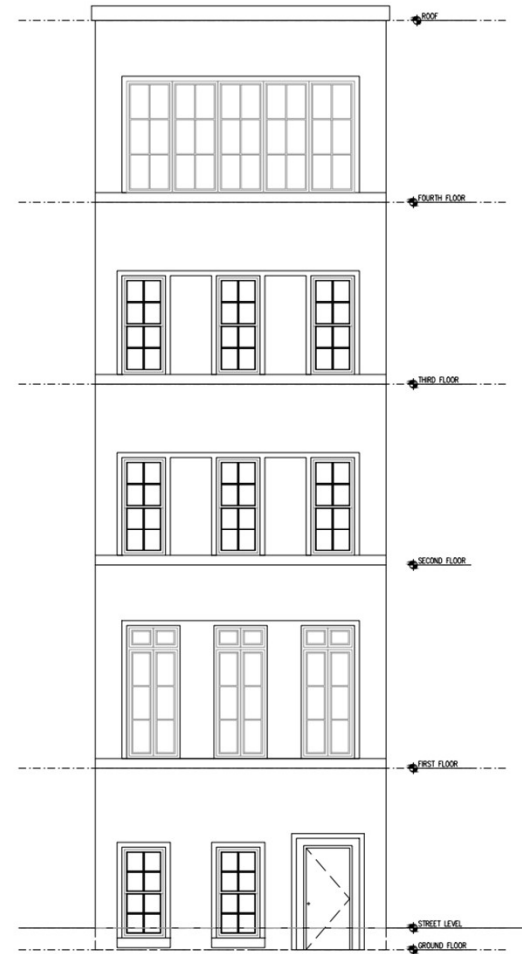

2 PROPOSED FRONT ELEVATION (WINDOW)  
1/4"=1'-0"

CLOSE UP OF UPPER WINDOWS, EXISTING

---



CLOSE UP OF 2 GROUND FLOOR WINDOWS, EXISTING

---



## 4-OVER-4 GRID WINDOWS MOCKUP



# PROPOSED WINDOWS

4-over-4 grid windows in metal-clad wood  
Anderson E series with an A754 casing in Black.

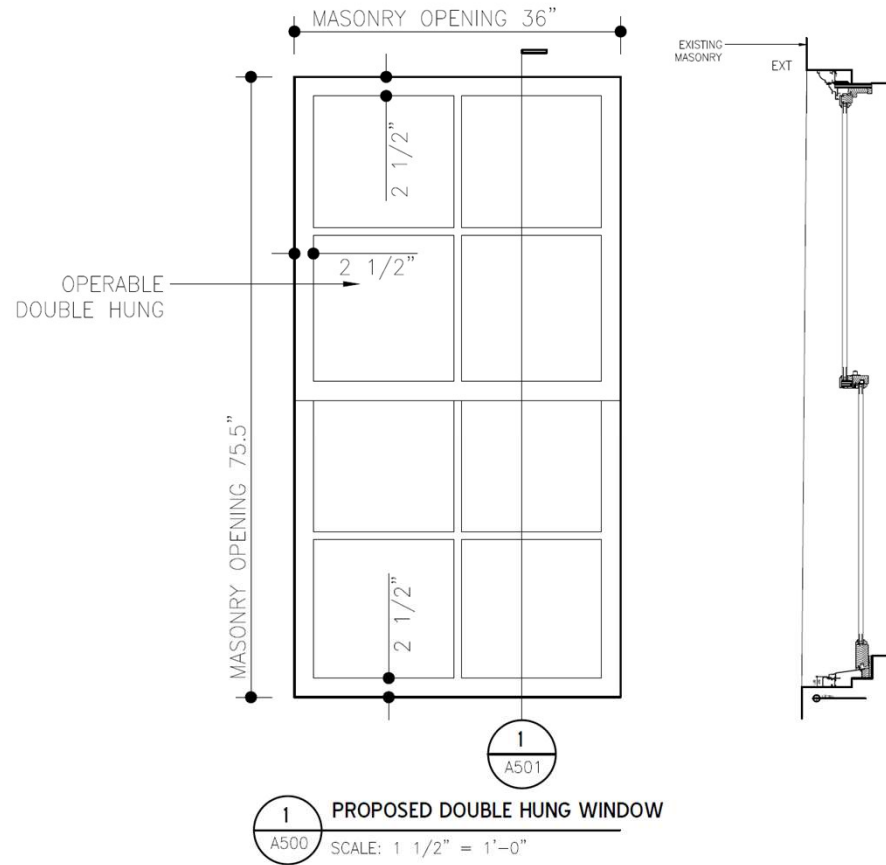
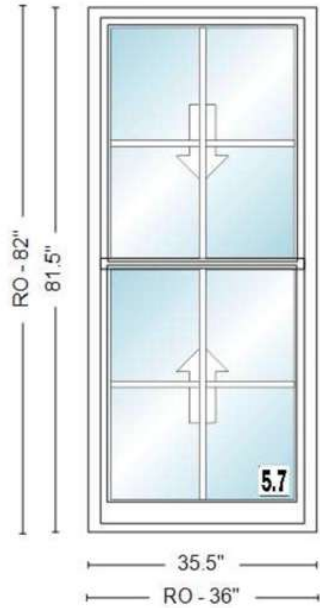

# BRICK MOULD

Double Hung & Single Hung Windows

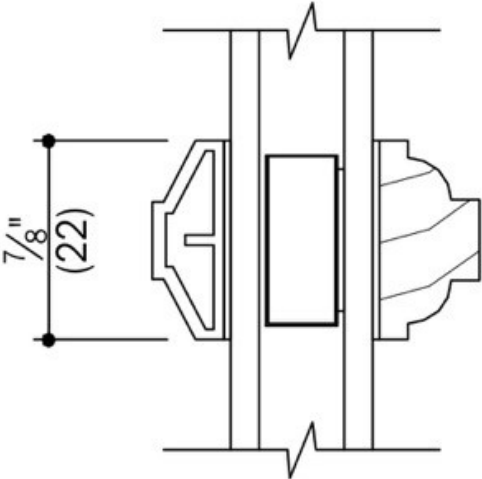

7/8" Int. Colonial, Ext. Chamfer  
Full Divided Light

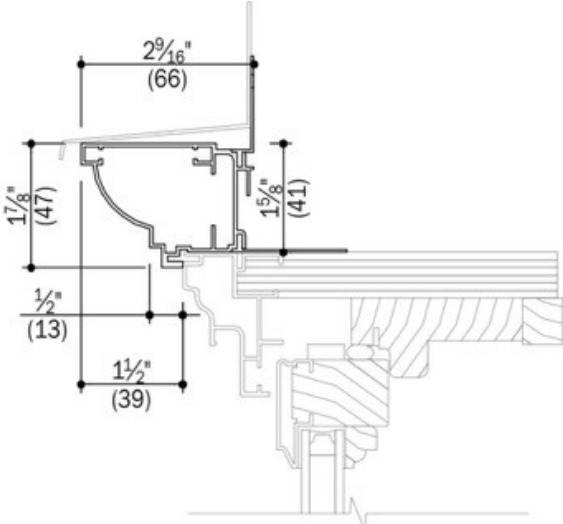

2" Ovolo Brick Mould (A754)



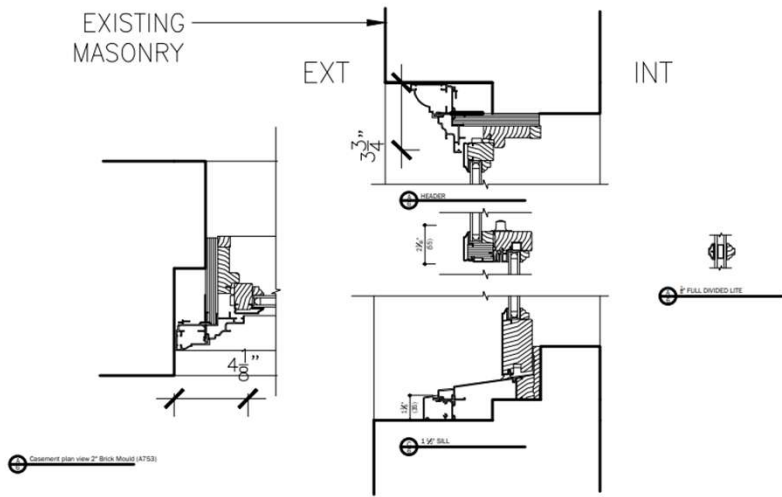

**1** WINDOW DETAILS - PROPOSED  
 A501 ANDERSEN ALUM. CLAD WOOD BLACK

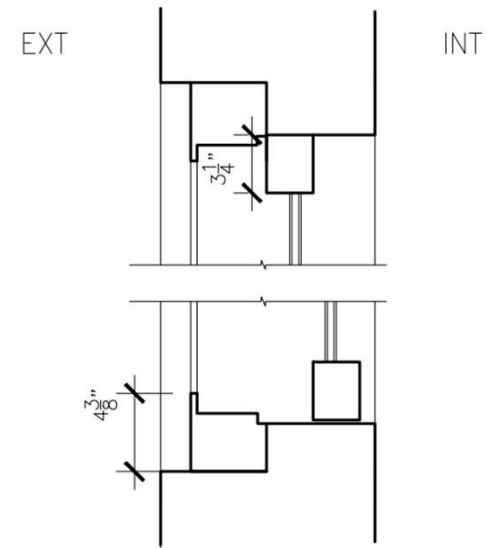

**2** EXISTING FOR REFERENCE  
 A501 ALUMINUM, WHITE

Next door neighbors with grid windows

6 Over 6



124 E 64<sup>th</sup> Street

6 Over 6



127 E 64<sup>th</sup> Street

June 9, 2026  
Public Hearing

The current proposal is:

Preservation Department – Item 8, LPC-26-05686

## 125 East 64th Street – Upper East Side Historic District Borough of Manhattan

To testify virtually, please join Zoom

**Webinar ID:** 165 868 4773

**Passcode:** 126605

By Phone: 646-828-7666 (NY)

833-435-1820 (Toll-free)

833-568-8864 (Toll-free)

**Note:** If you want to testify virtually on an item, join the Zoom webinar at the agenda's "Be Here by" time (about an hour in advance). When the Chair indicates it's time to testify, "raise your hand" via the Zoom app if you want to speak (\*9 on the phone). Those who signed up in advance will be called first.