

June 2, 2026
Public Hearing

The current proposal is:

Preservation Department – Item 7, LPC-26-10511

26 Bleecker Street – Noho East Historic District

Borough of Manhattan

To testify virtually, please join Zoom

Webinar ID: 165 104 6126

Passcode: 717488

By Phone: 646-828-7666 (NY)

833-435-1820 (Toll-free)

833-568-8864 (Toll-free)

Note: If you want to testify virtually on an item, join the Zoom webinar at the agenda's "Be Here by" time (about an hour in advance). When the Chair indicates it's time to testify, "raise your hand" via the Zoom app if you want to speak (*9 on the phone). Those who signed up in advance will be called first.



26 Bleecker Street, view from the northwest



Noho East Historic District

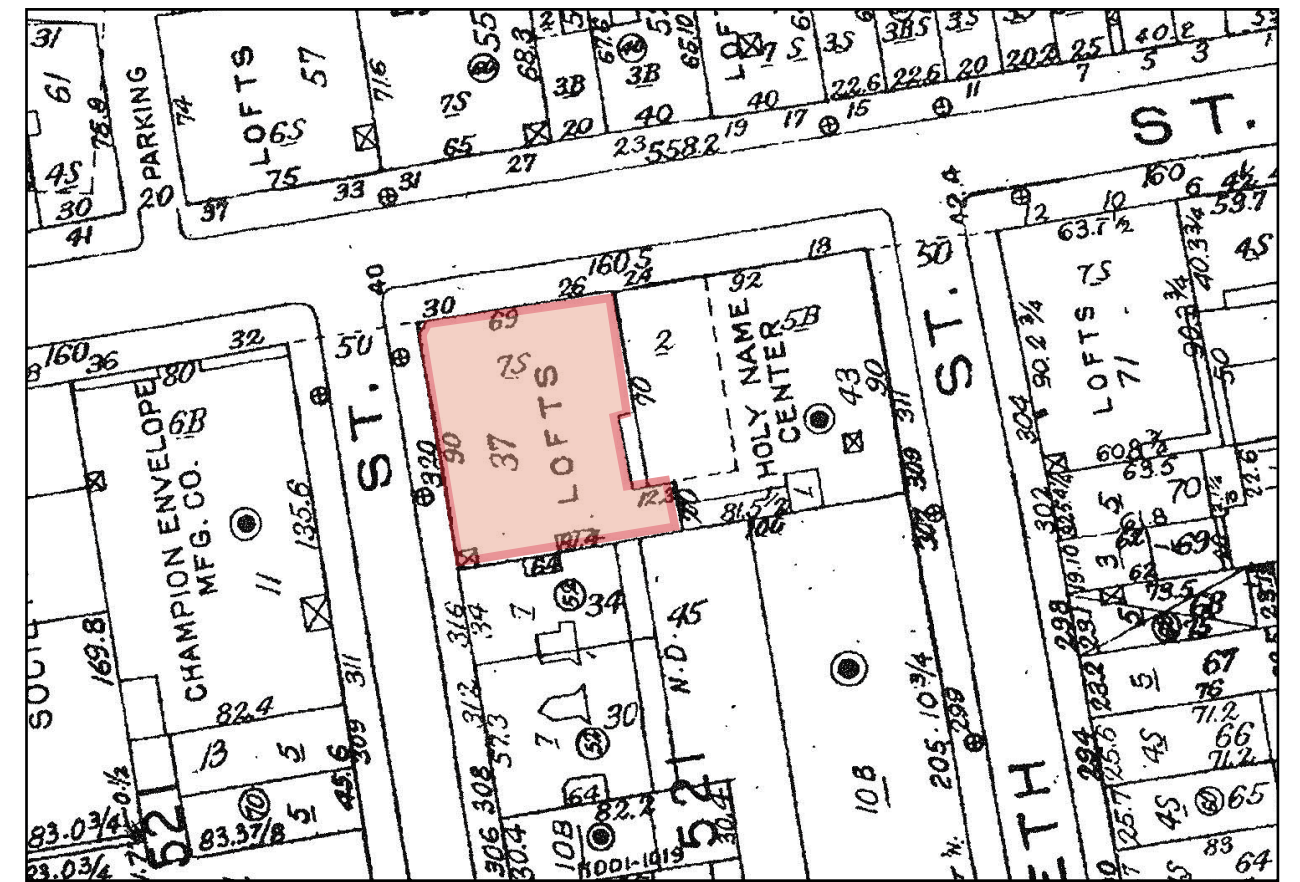

Property Location



Blecker Street Facade, Facing South, 2026



Mott Street, 2026







Bleecker Elevation, facing east



Corner of Bleecker & Mott Street



Mott Street Elevation, facing southeast



Louver Details, Bleeker Street facade



Window Details, Mott Street facade



Blind Windows and Existing Elevator Bulkhead, Mott Street Elevation



Existing Parapet Details, corner of Mott and Bleeker



Northeast corner of the Top of house



From Blecker Street, East Side Elevation



Upper Floor of East Side Elevation



Existing Base Details, Mott Street elevation



Existing Base Details, Mott Street elevation

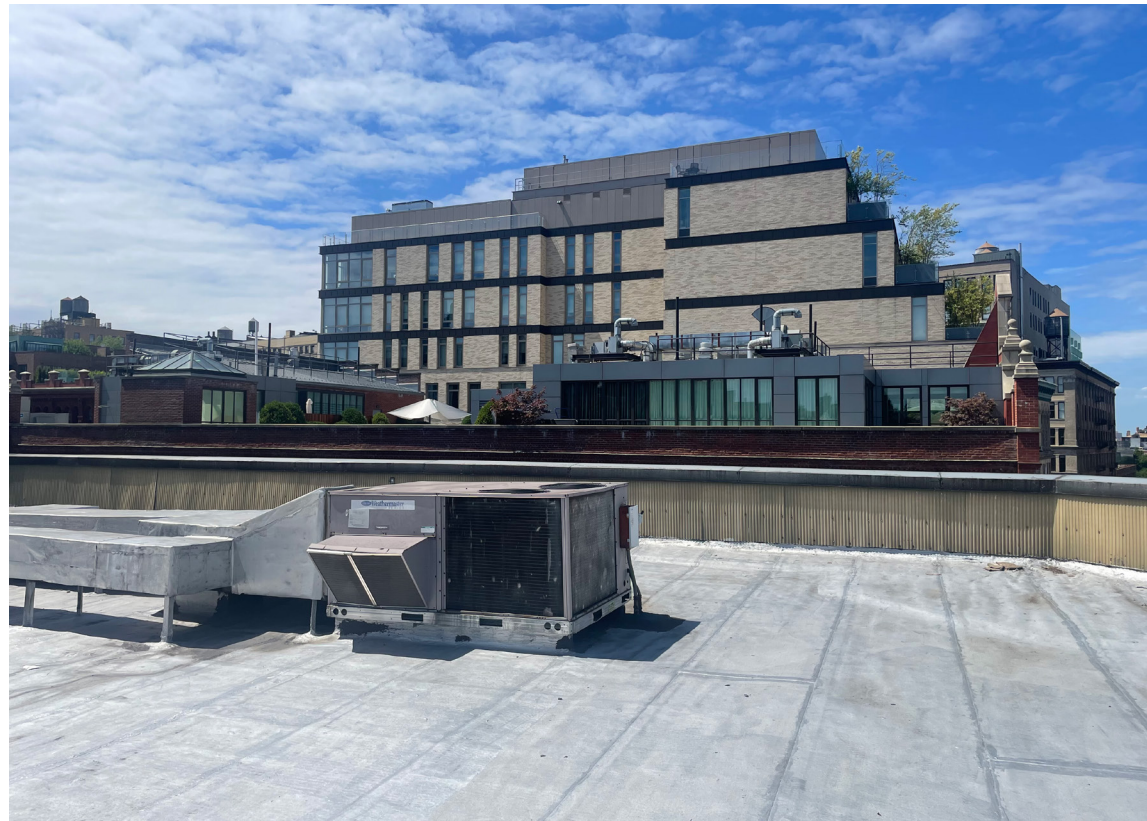

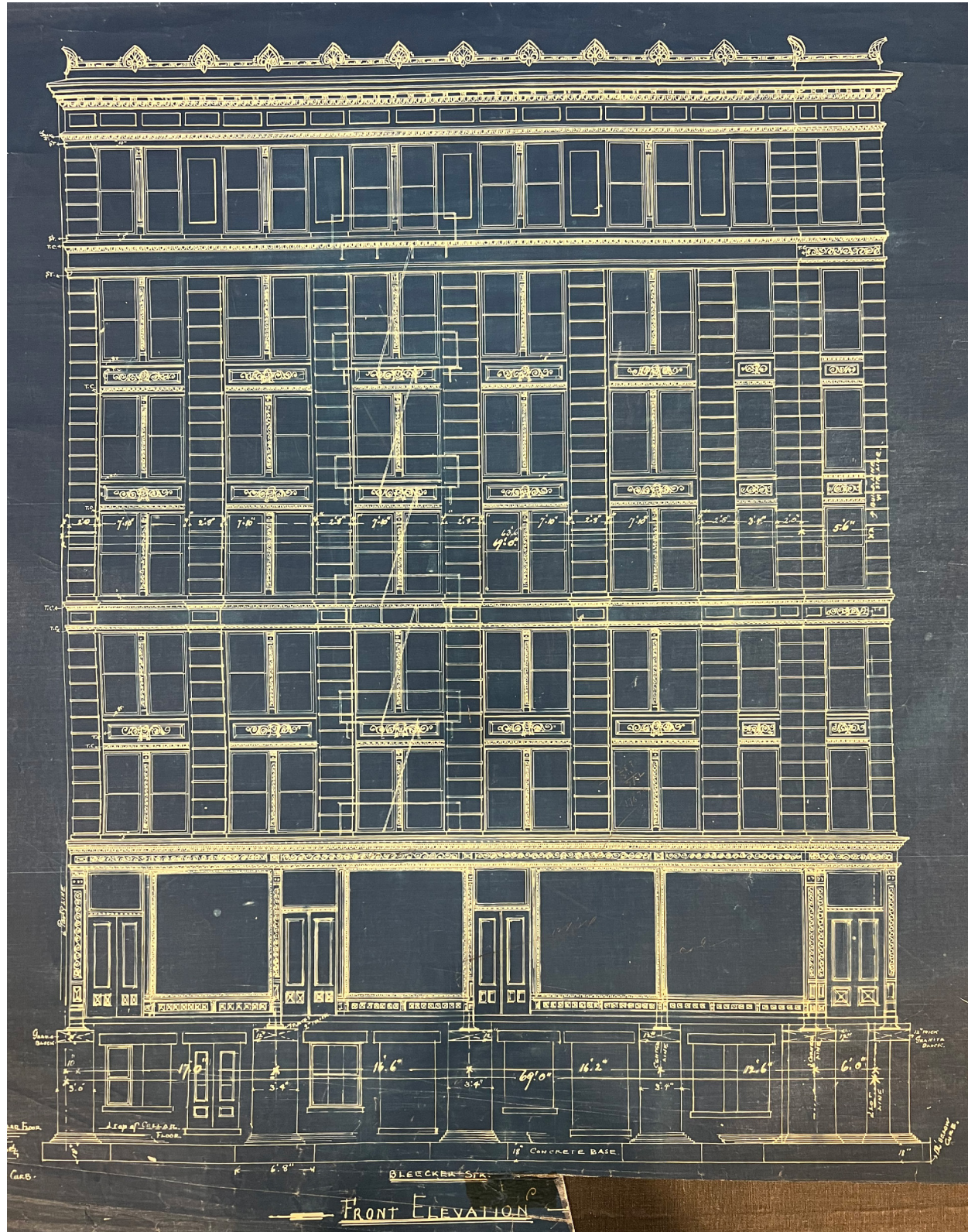

Blecker Street Elevation, 1900



Mott Street Elevation, 1900



1904 (New York Public Library)

1940 Tax Photo (Muni)

1940 Tax Photo (Muni)(Mott Street)

2003 Designation Photo (LPC) (Mott Street)

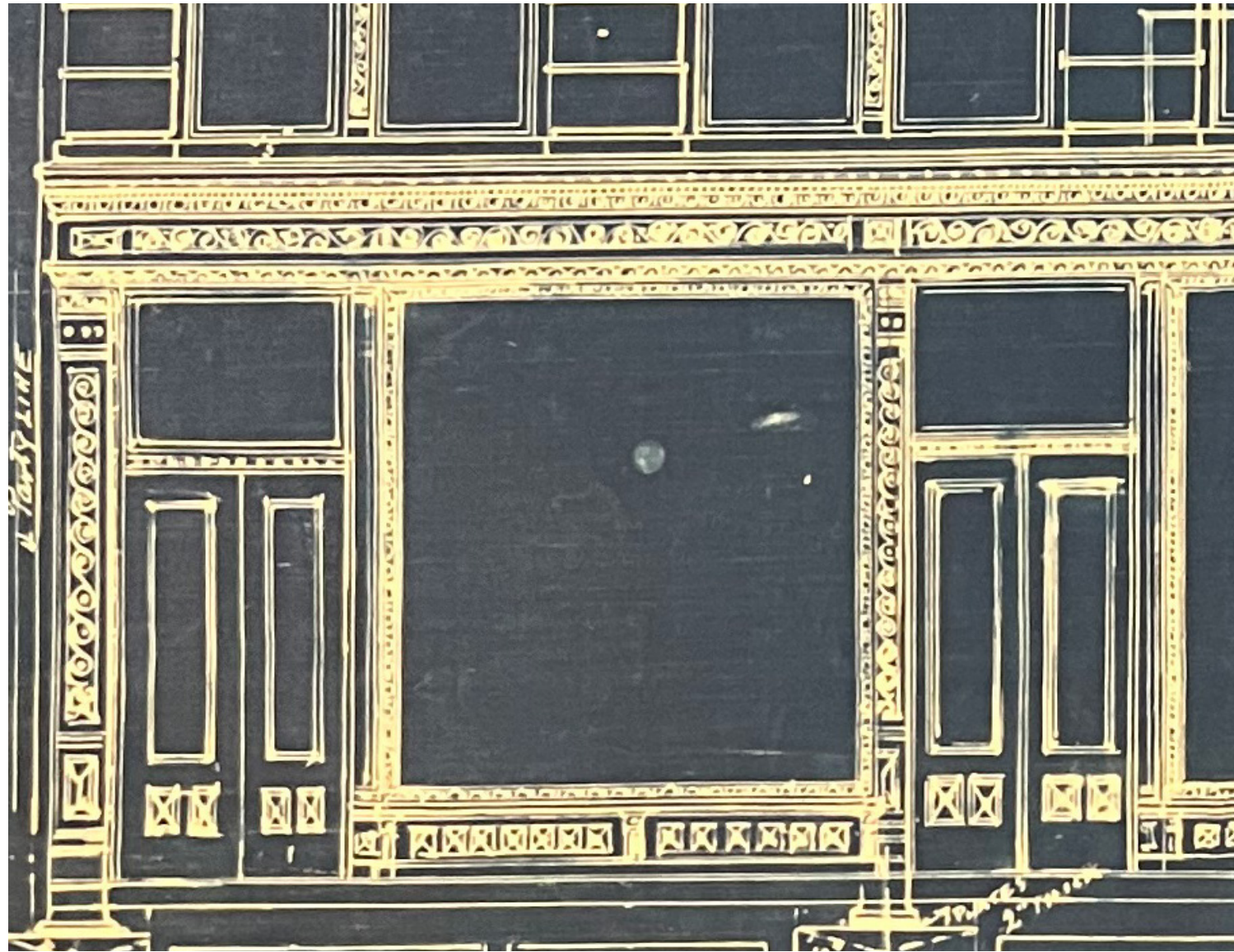

Blecker Street Elevation, 1900



Blecker Street Elevation, 2026

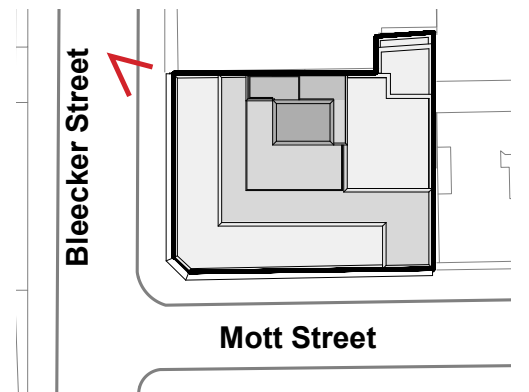



Mott Street Elevation, 1900



Mott Street Elevation, 2026

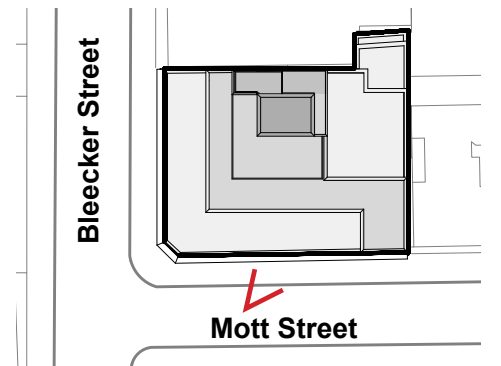



Mott Street Elevation, 1900



Mott Street Elevation, 2026

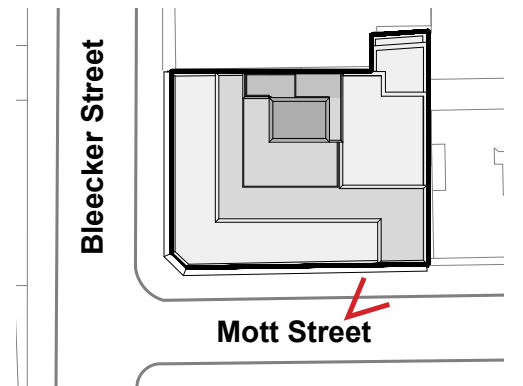

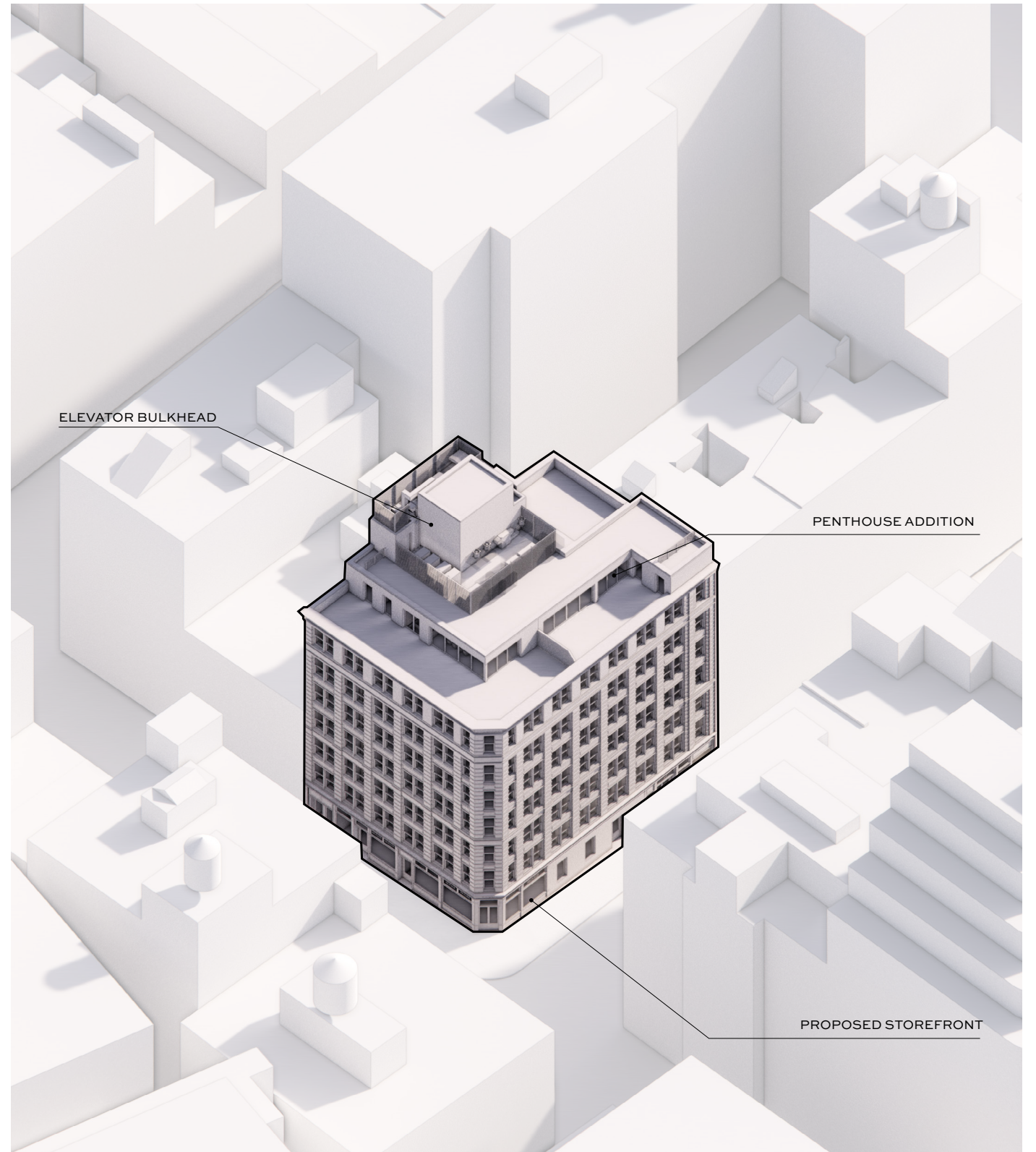
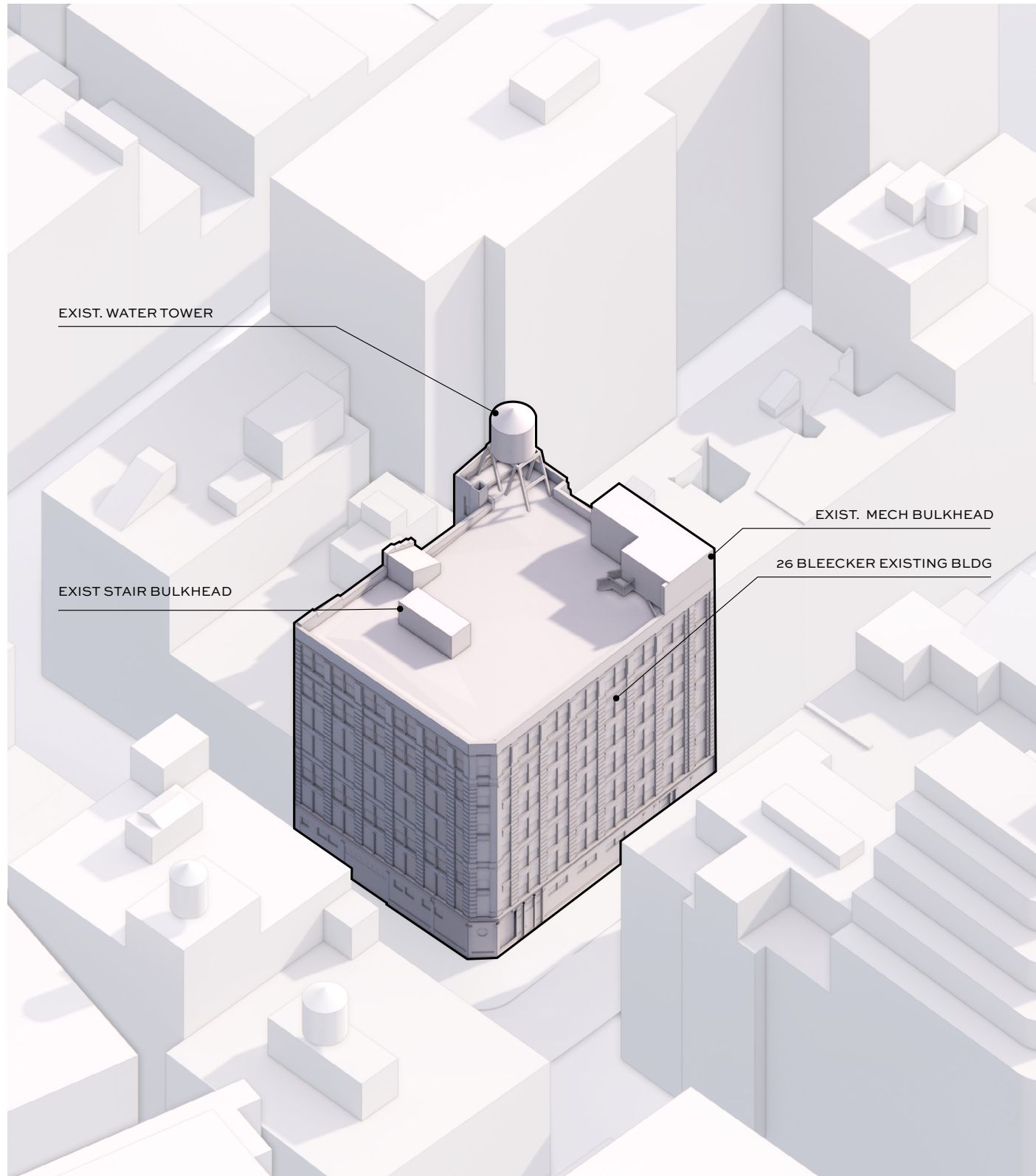



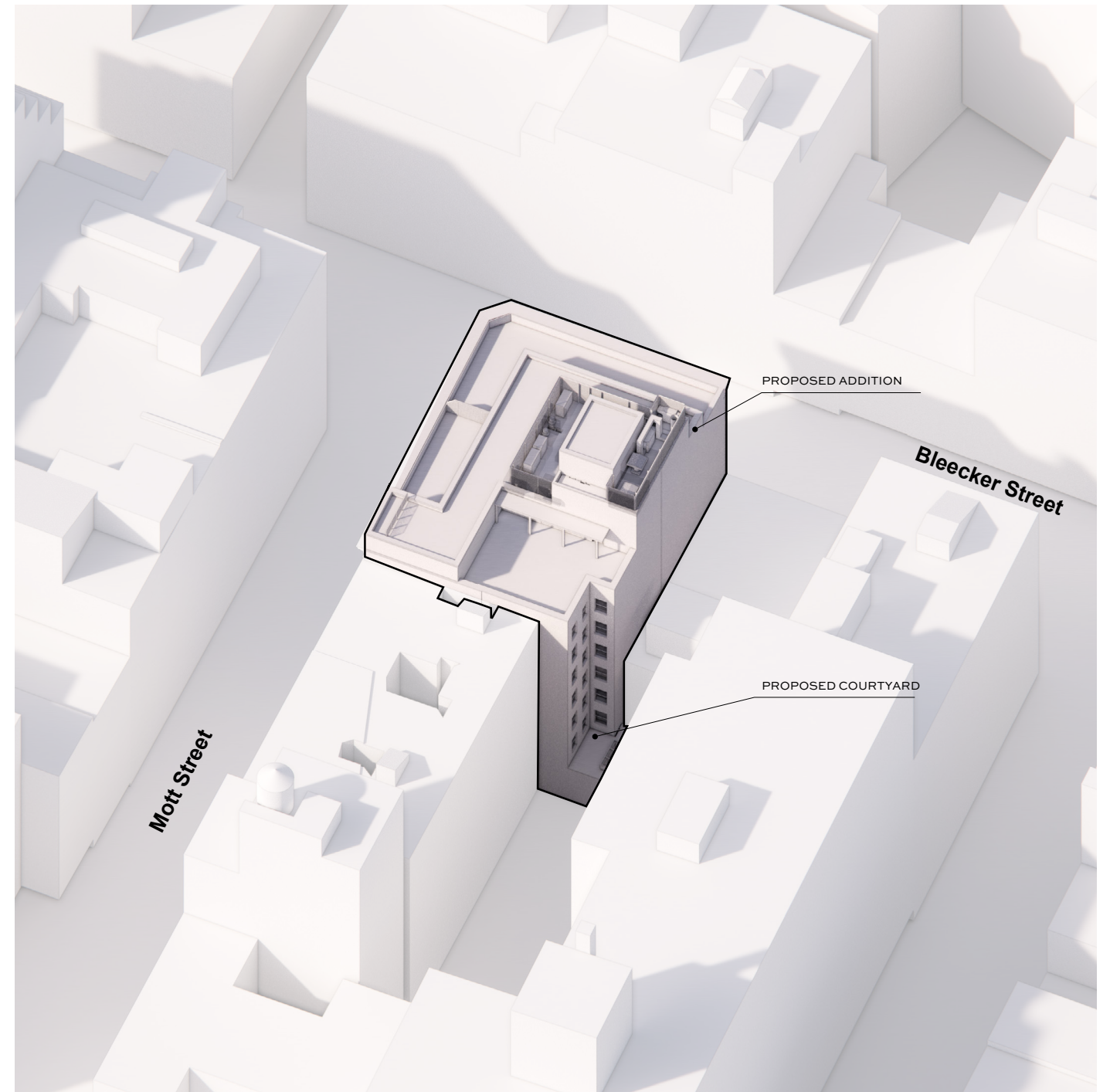
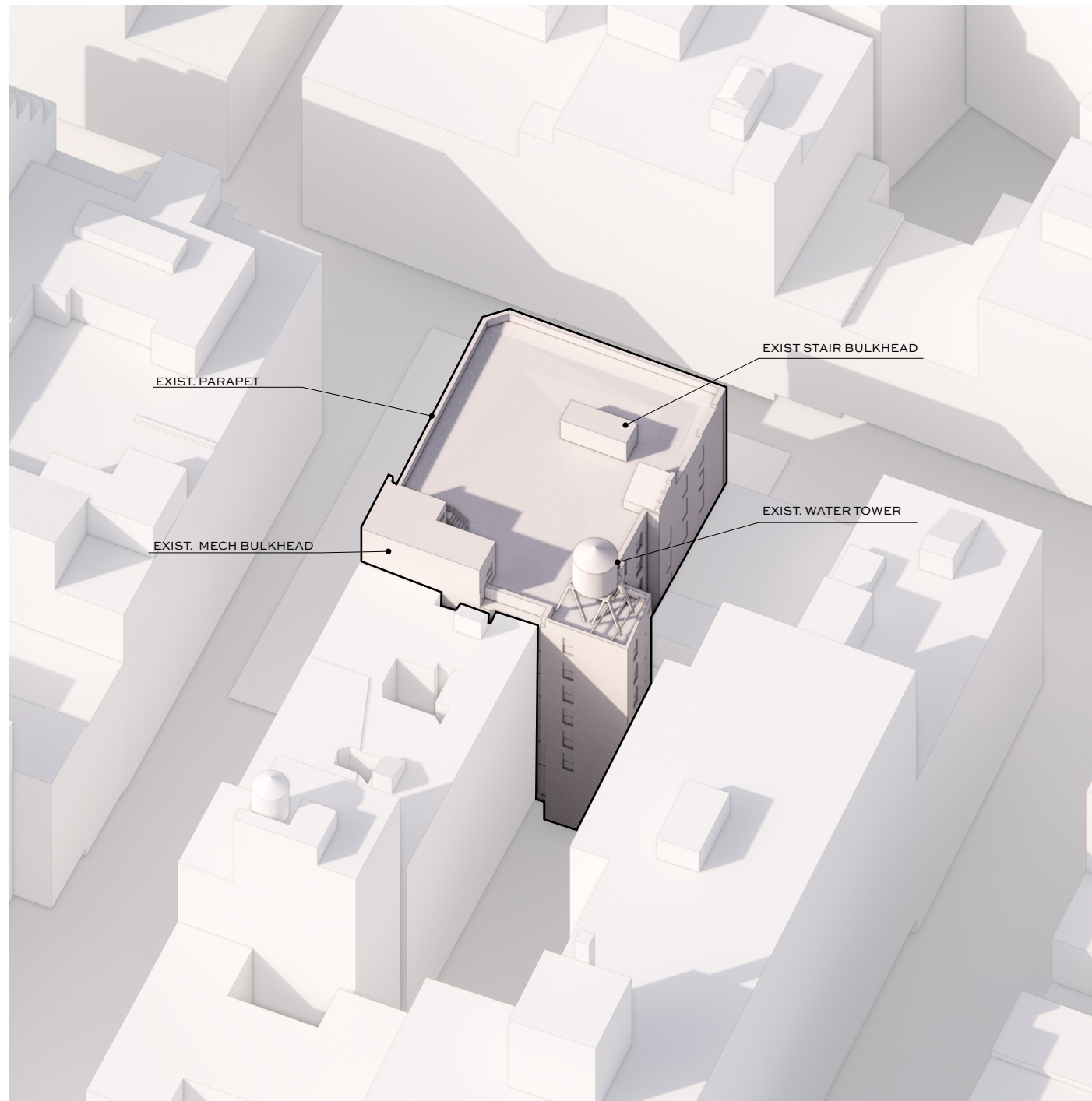



EXISTING



PROPOSED

- New Stair And Elevator Bulkheads
- New One-Story Rooftop Addition
- New Pressed Metal Cornice
- ROOF
85' - 0"
- Facade Uplighting At Brick Piers
- 8TH FLOOR
76' - 2"
- 7TH FLR
64' - 2"
- 6TH FLR
53' - 11 1/2"
- Window Replacement (Throughout)
- 5TH FLR
43' - 9"
- Brick, Terra Cotta And Cast Iron Restoration (Throughout)
- 4TH FLR
33' - 6 1/2"
- 3RD FLR
23' - 4"
- New Exterior Uplighting
- 2ND FLR
13' - 4"
- New Wood Storefront Infill W/Historic Cast Iron Columns
- 1ST FLR
0"



EXISTING



PROPOSED

- Elevator Bulkheads
- New One-Story Rooftop Addition
- New Pressed Metal Cornice

- ROOF 85' - 0"
- Facade Up-lighting At Brick Piers
- 8TH FLOOR 76' - 2"
- Brick, Terra Cotta And Cast Iron Restoration (Throughout)
- 7TH FLR 64' - 2"
- Window Replacement (Throughout)
- 6TH FLR 53' - 11 1/2"
- Restore Glazing To Filled-In Windows
- 5TH FLR 43' - 9"
- Louver
- 4TH FLR 33' - 6 1/2"
- New Exterior Up-lighting
- 3RD FLR 23' - 4"
- New Wood Storefront Infill W/Historic Cast Iron Columns
- 2ND FLR 13' - 4"
- Enlarged Ground Floor Windows
- 1ST FLR 0"



Proposed Bulkhead Cladding
Zinc Flat Panel & Reveal Cladding
Color
Pre-Weathered Zinc Panels

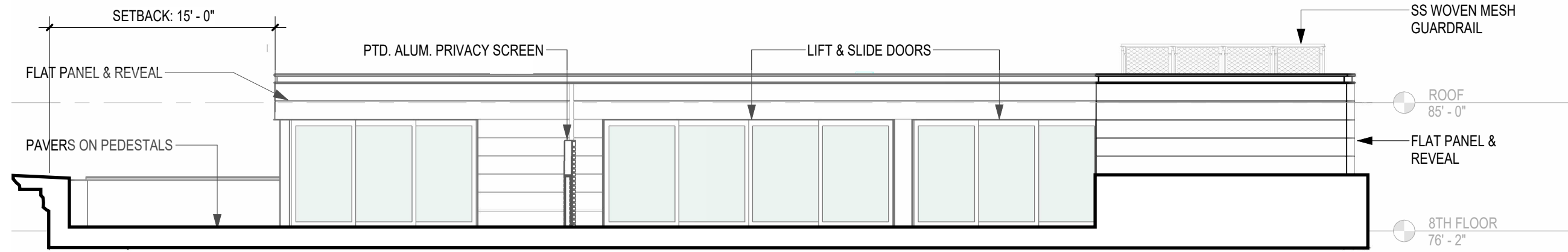

① PH ADDITION - WEST ELEVATION - MOTT ST
1/8" = 1'-0"



Rooftop Mechanical Screen
Color
RAL 9023 Pearl Dark Grey

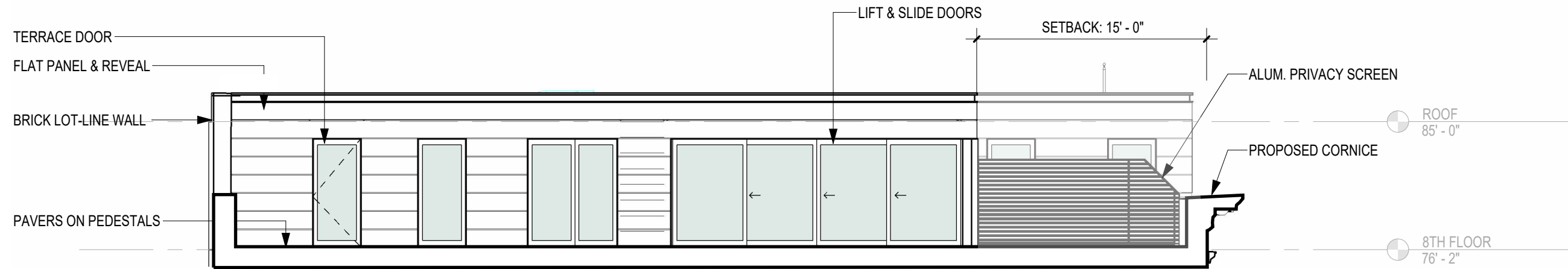

② PH ADDITION - NORTH ELEVATION - BLEECKER ST
1/8" = 1'-0"

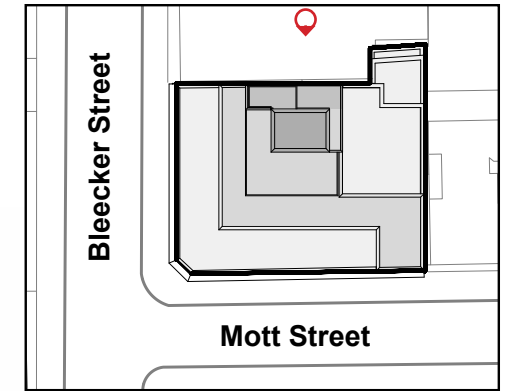

EXISTING

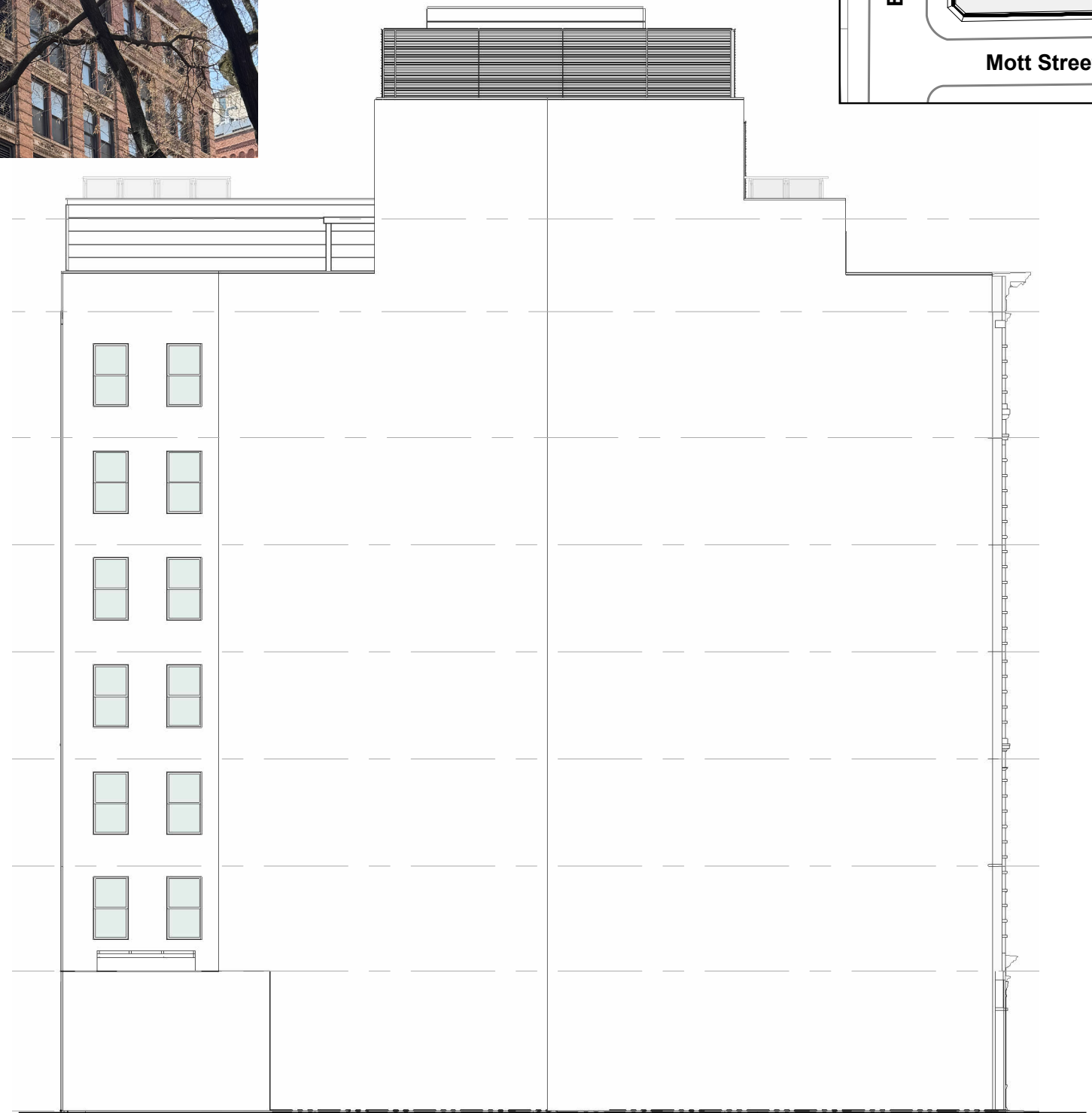

PROPOSED

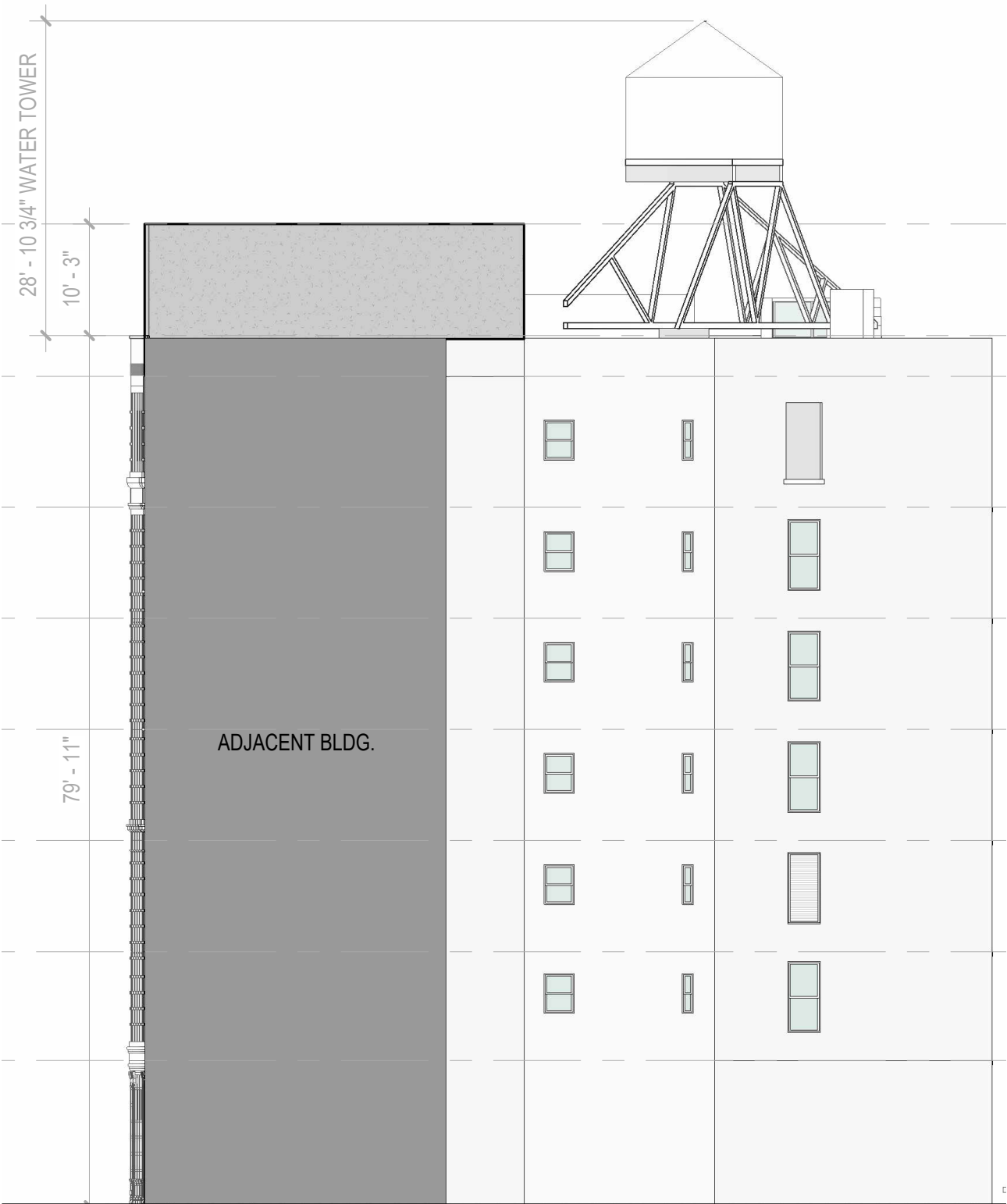

EXISTING

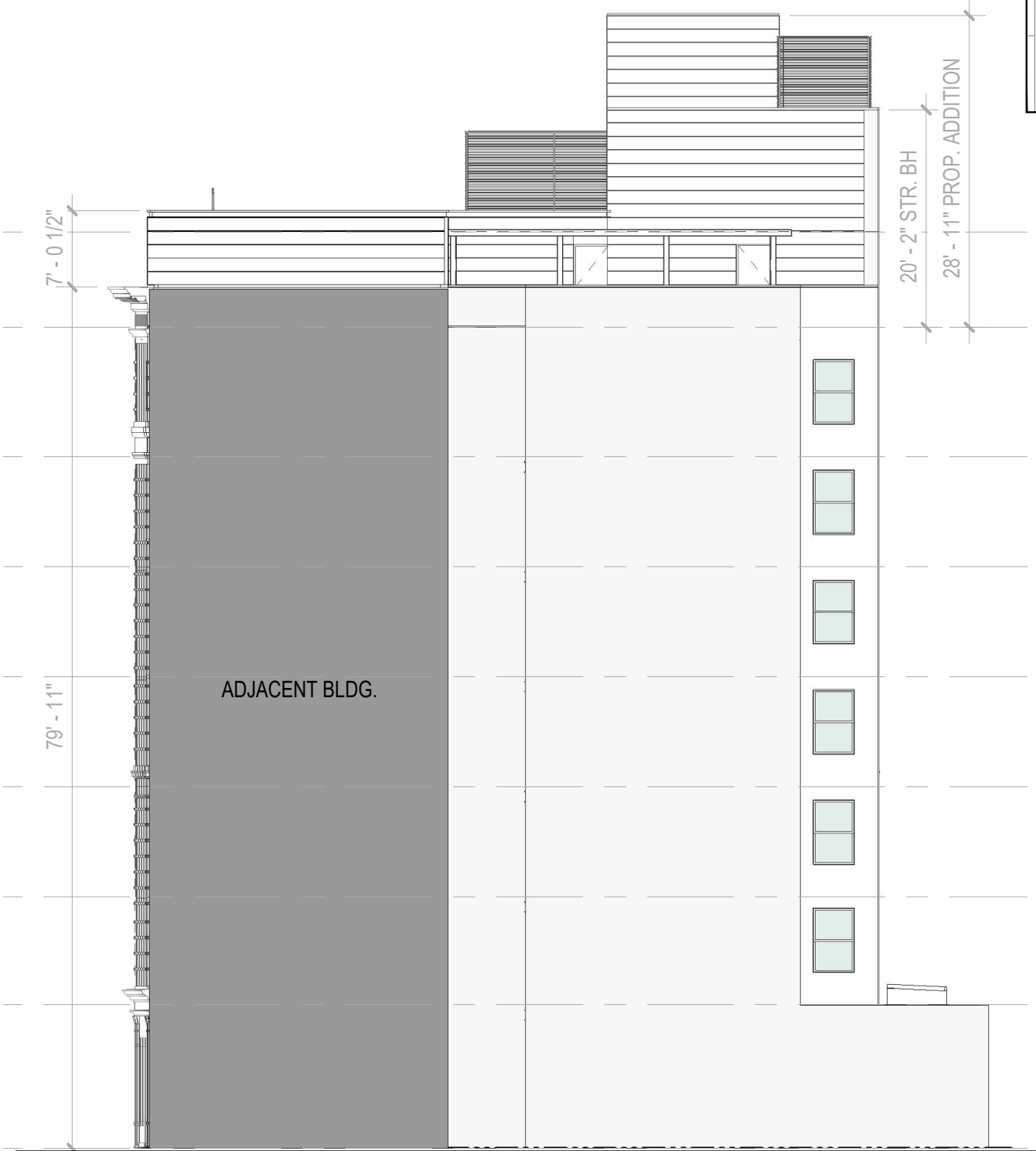

PROPOSED

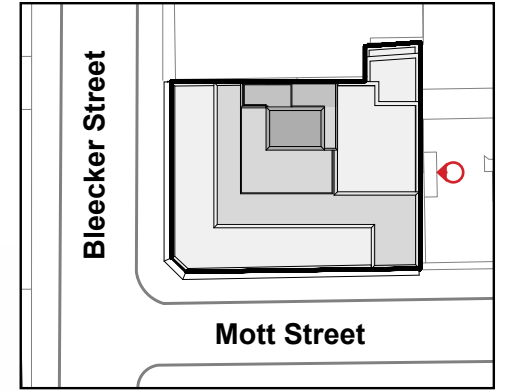

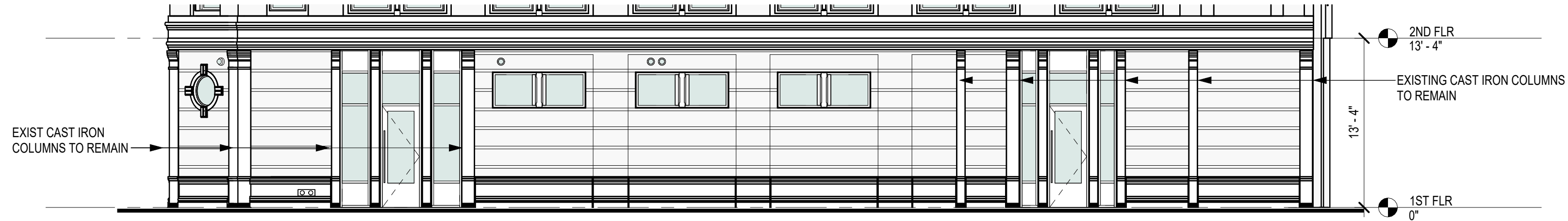

EXISTING MOTT STREET ELEVATION



PROPOSED MOTT STREET ELEVATION

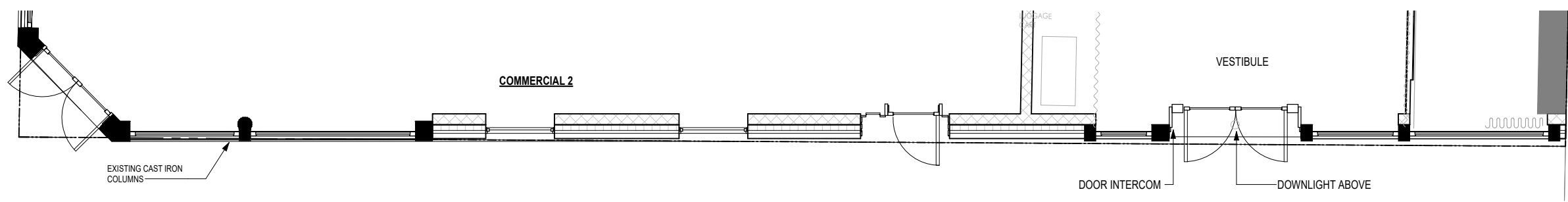

PROPOSED STOREFRONT PLAN

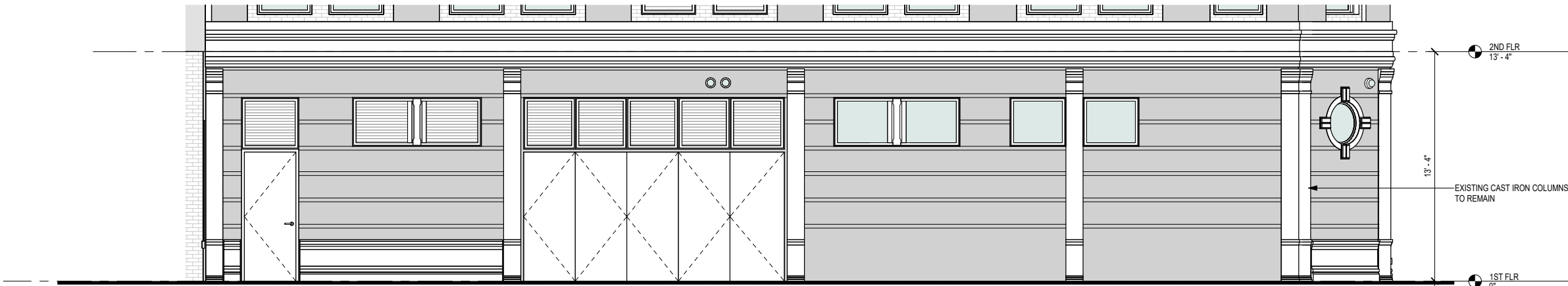

EXISTING BLEECKER STREET ELEVATION

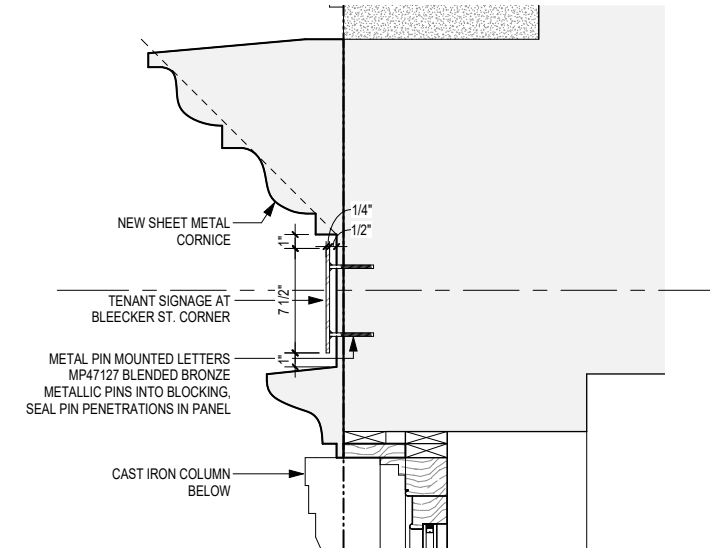

PIN LETTERS AT CORNICE

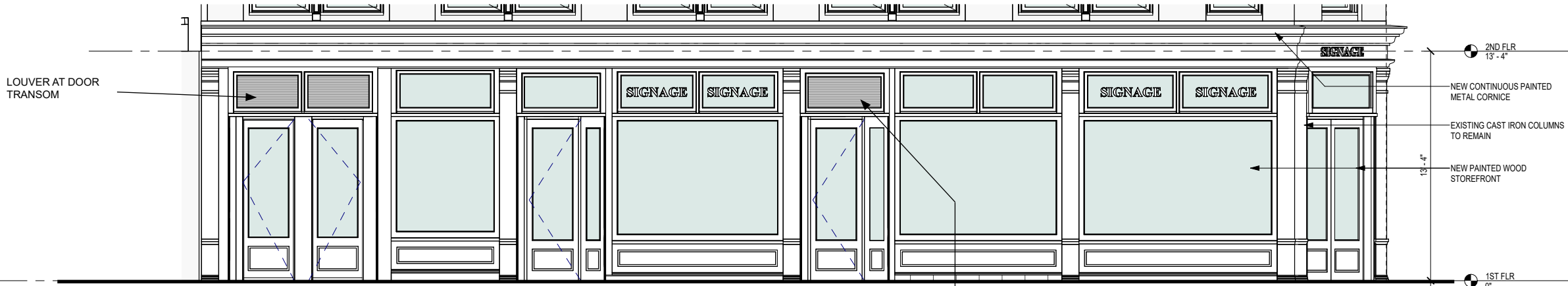

PROPOSED BLEECKER STREET ELEVATION



PIN LETTERS AT CORNICE

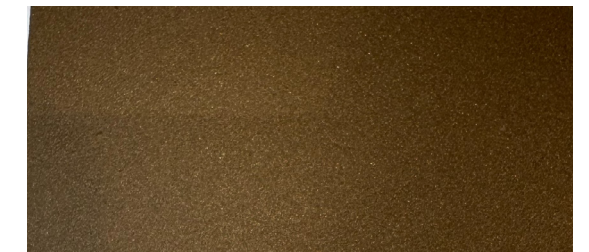

MP47127 BLENDED BRONZE

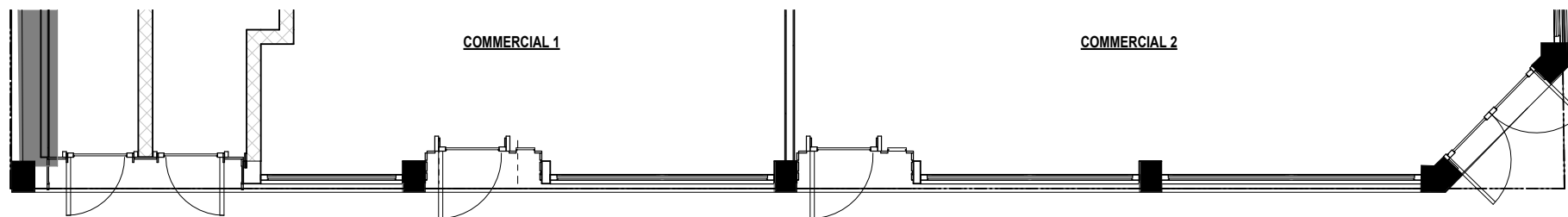

PROPOSED STOREFRONT PLAN



GLASS TRANSOM DECAL SIGNAGE

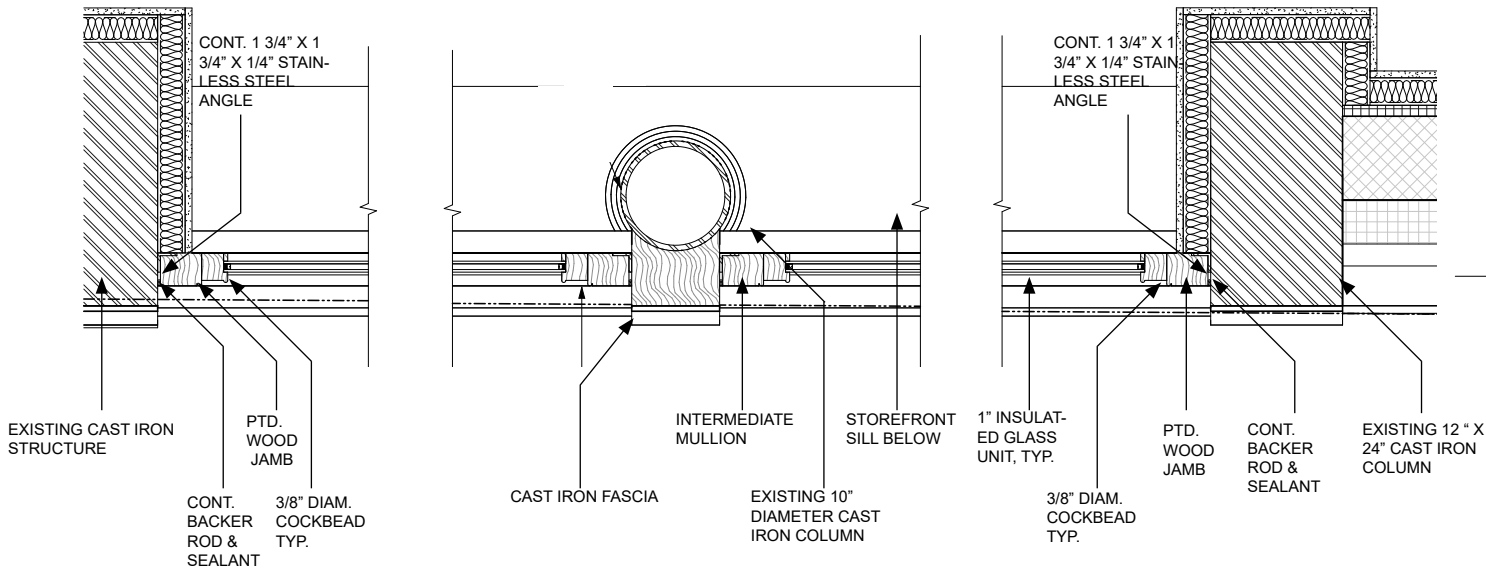

STOREFRONT PLAN DETAIL

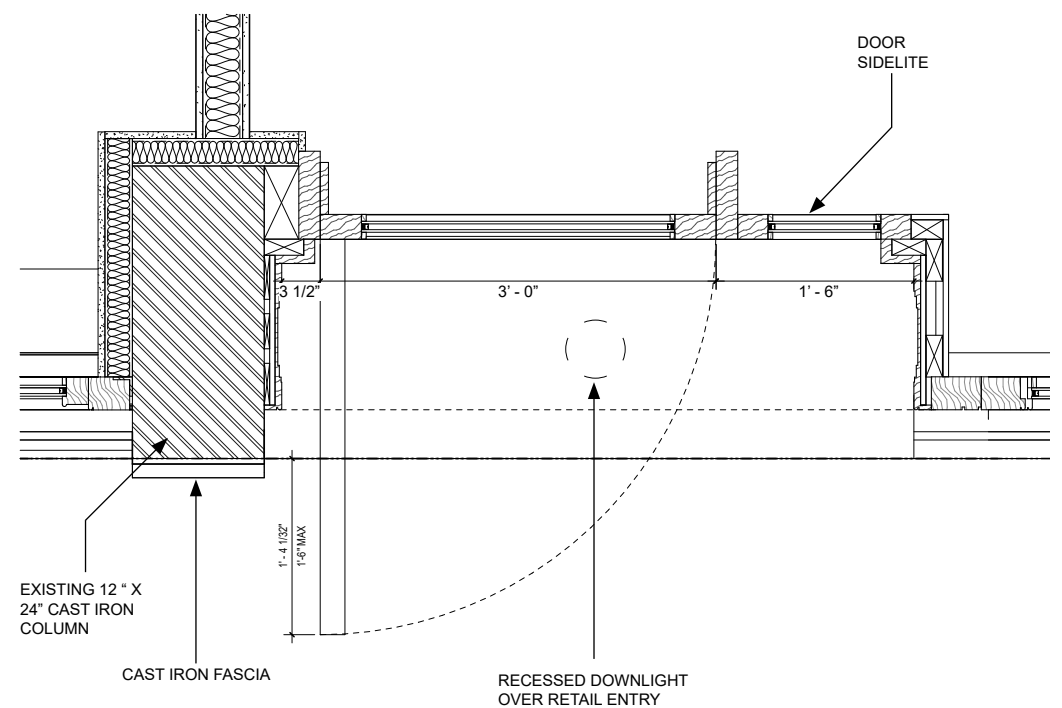

ENTRY PLAN DETAIL

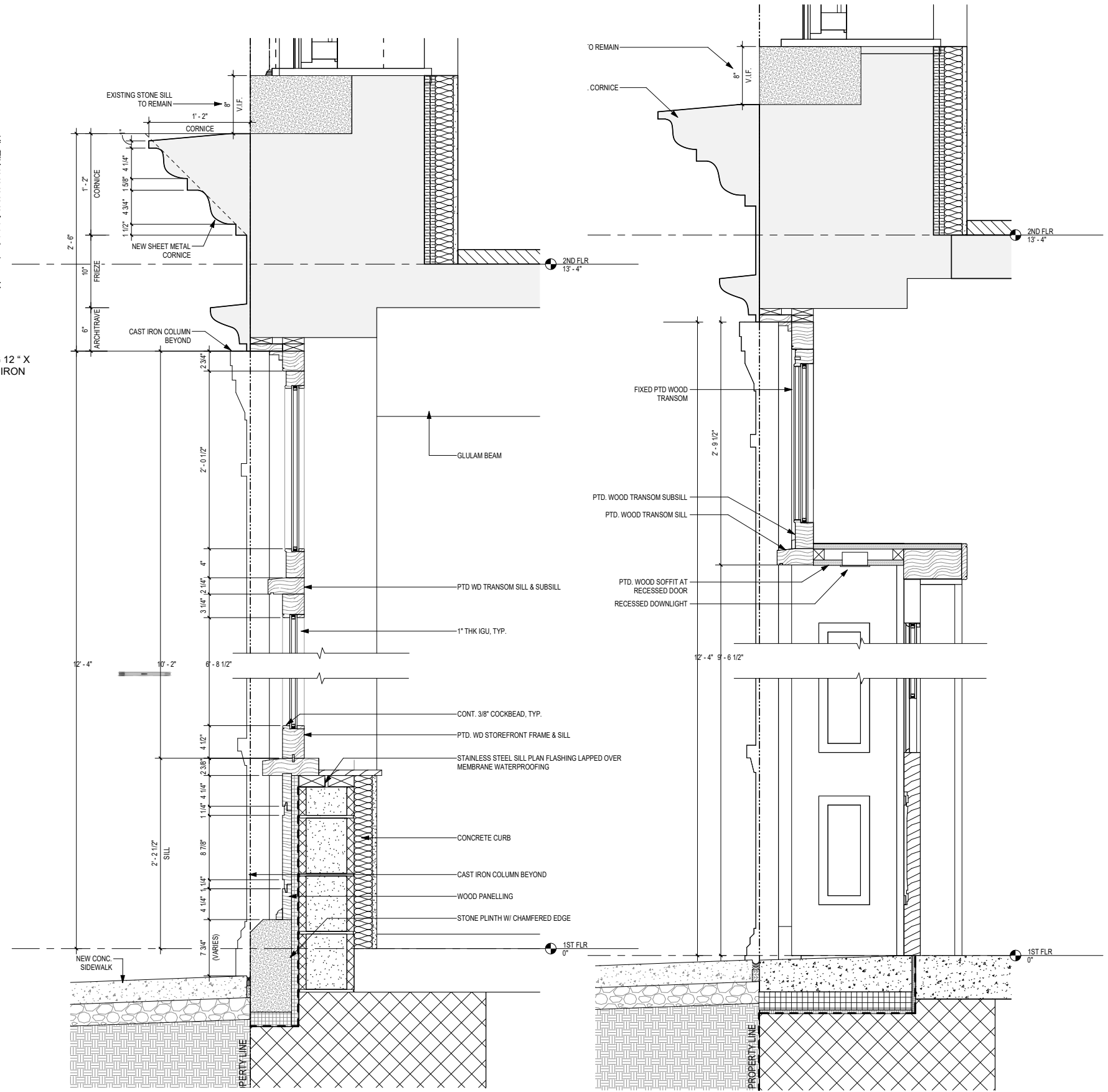

STOREFRONT SECTION AT WINDOW

STOREFRONT SECTION AT DOOR

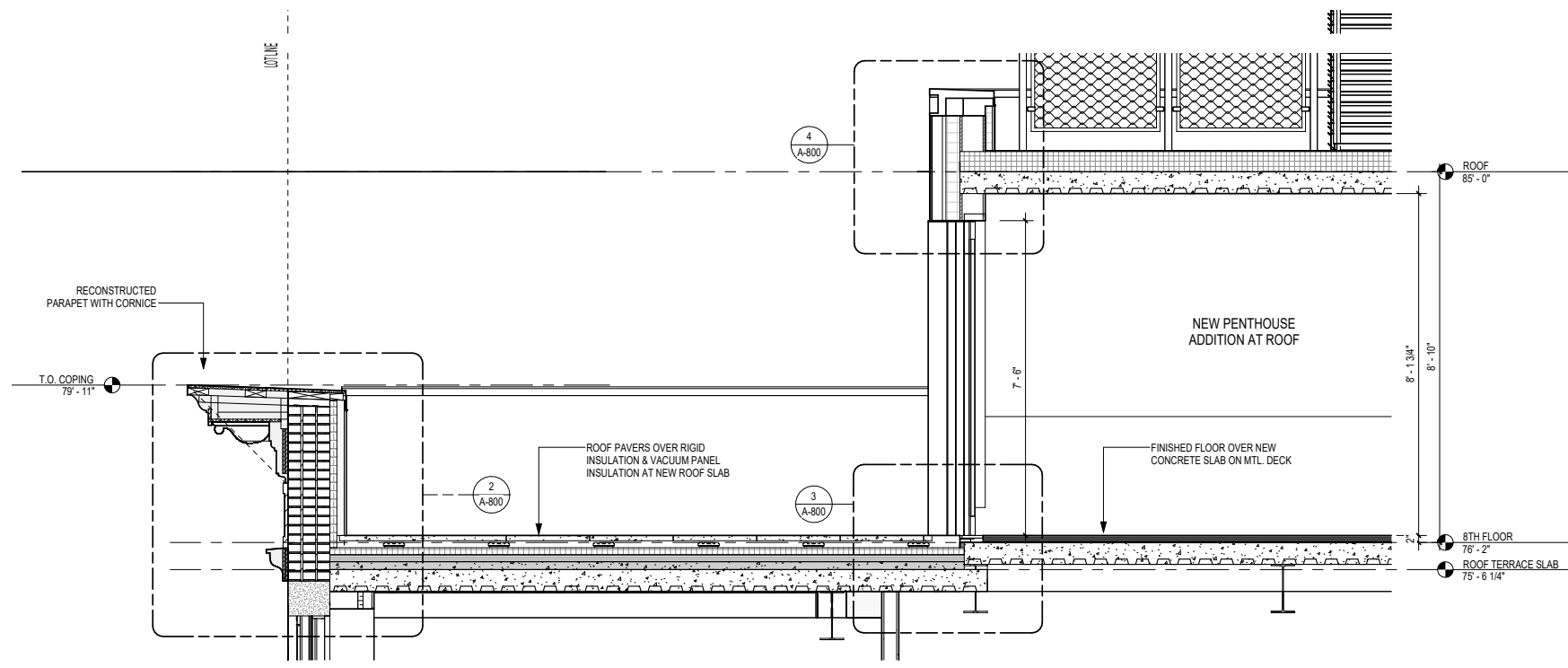

① PENTHOUSE PARAPET SECTION
1/2" = 1'-0"

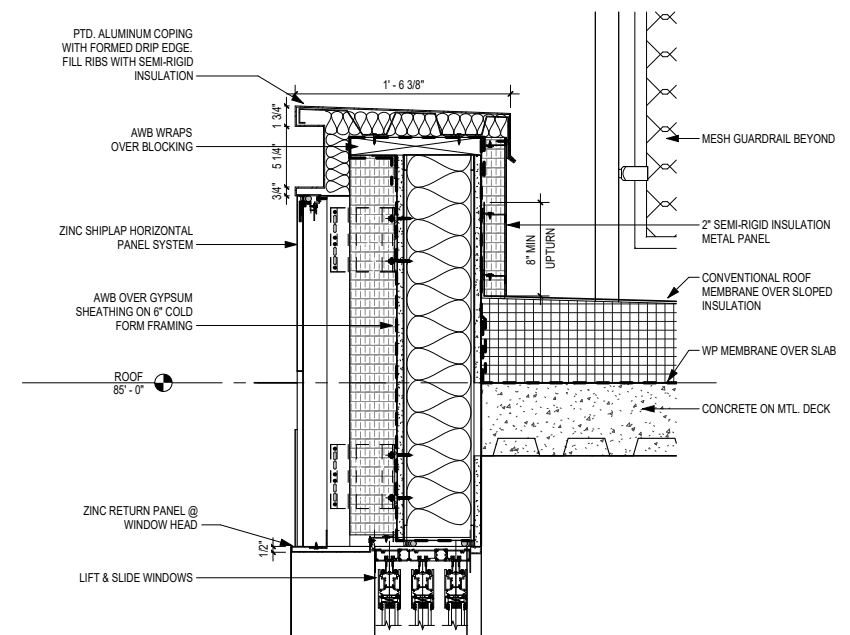

④ PARAPET DETAIL @ ADDITION
1 1/2" = 1'-0"

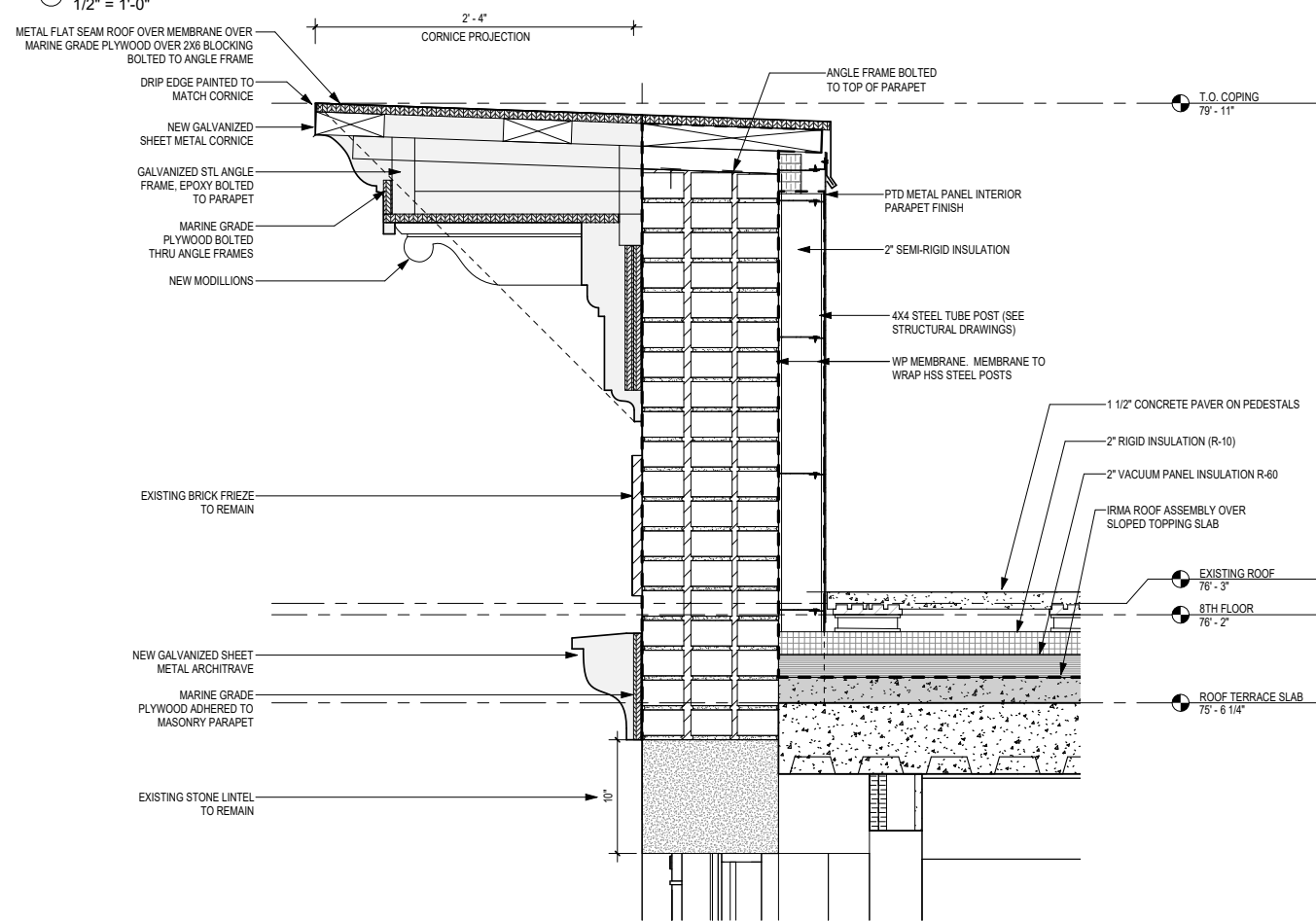

② SECTION DETAIL AT PARAPET CORNICE RECONSTRUCTION
1 1/2" = 1'-0"

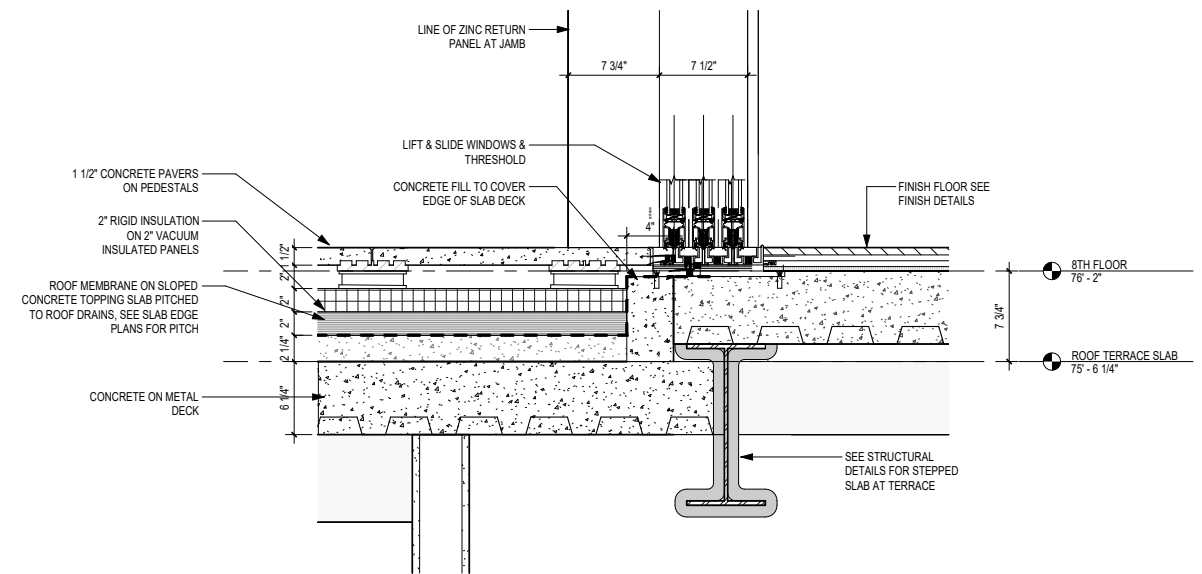

③ DETAIL @ TERRACE THRESHOLD
1 1/2" = 1'-0"

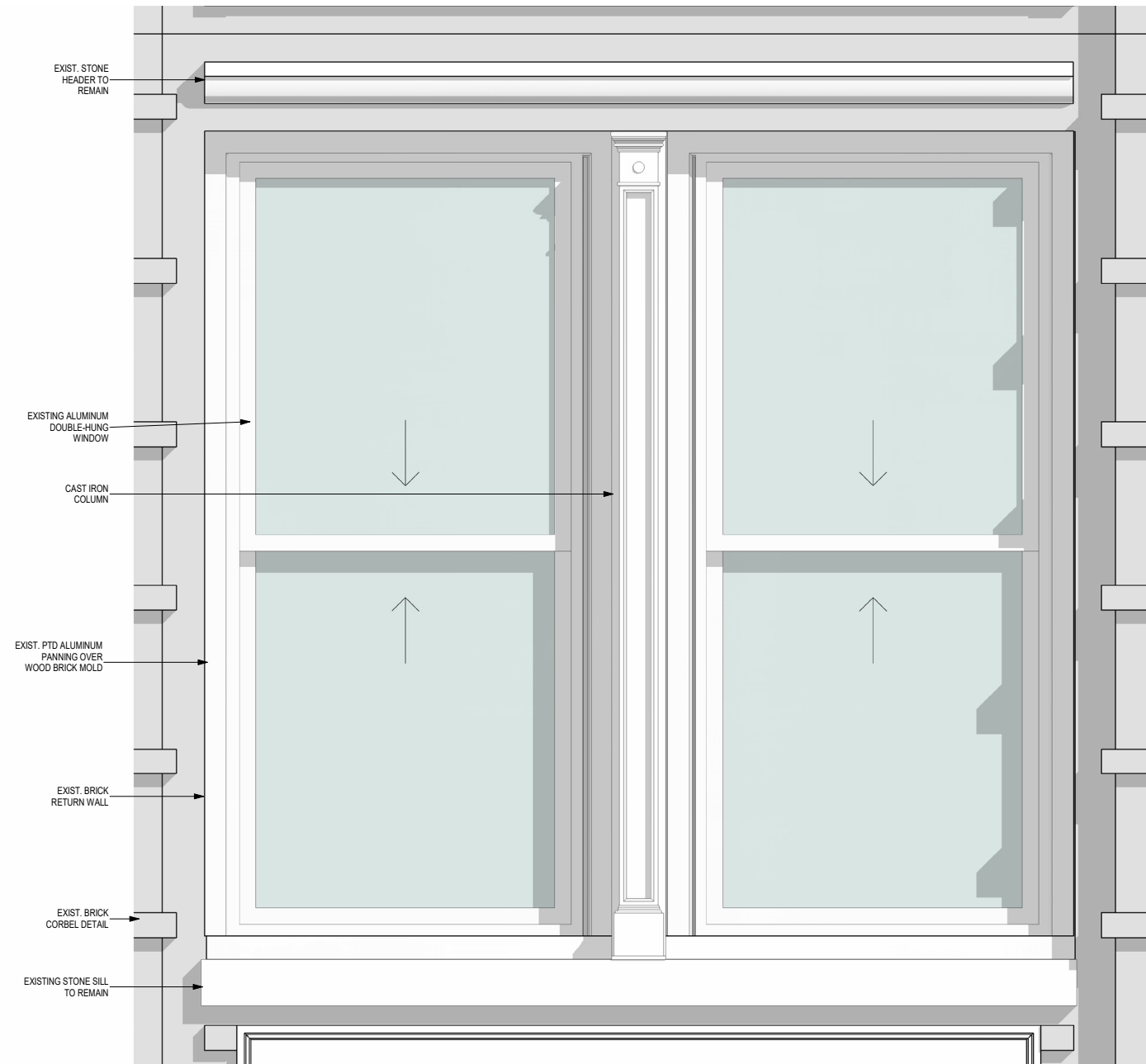
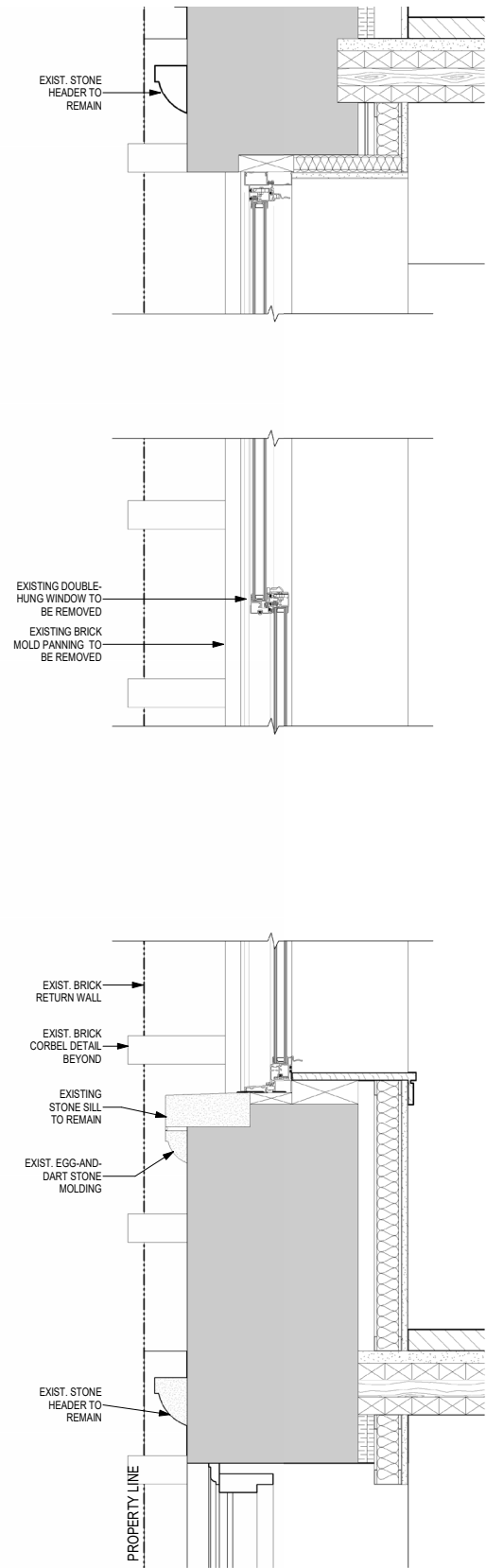

② EXISTING DOUBLE-HUNG WINDOW ELEVATION
1 1/2" = 1'-0"

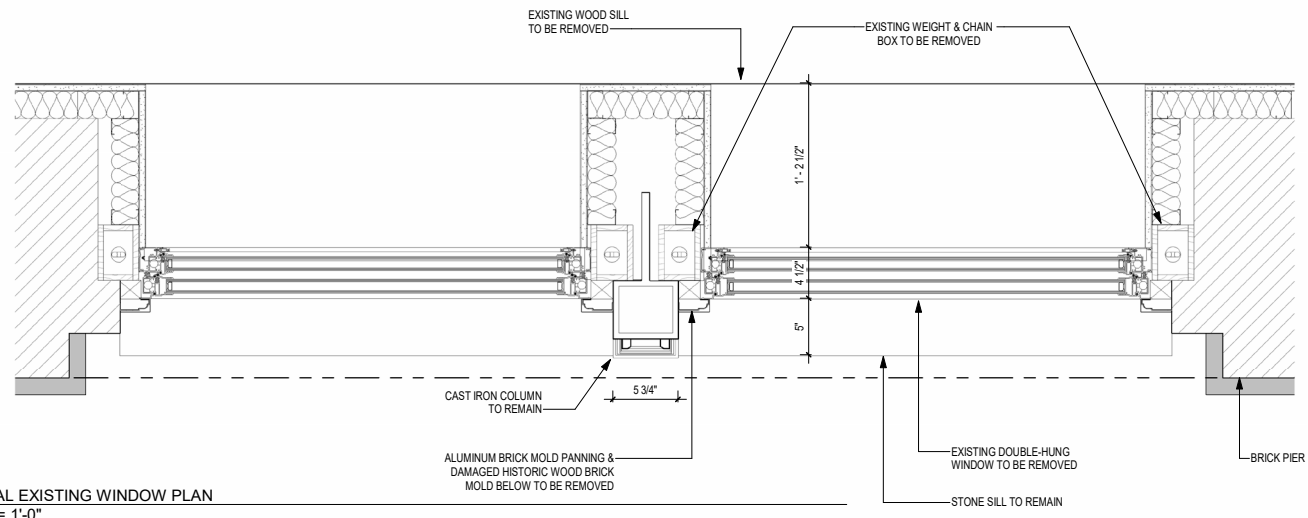

① TYPICAL EXISTING WINDOW PLAN
1 1/2" = 1'-0"

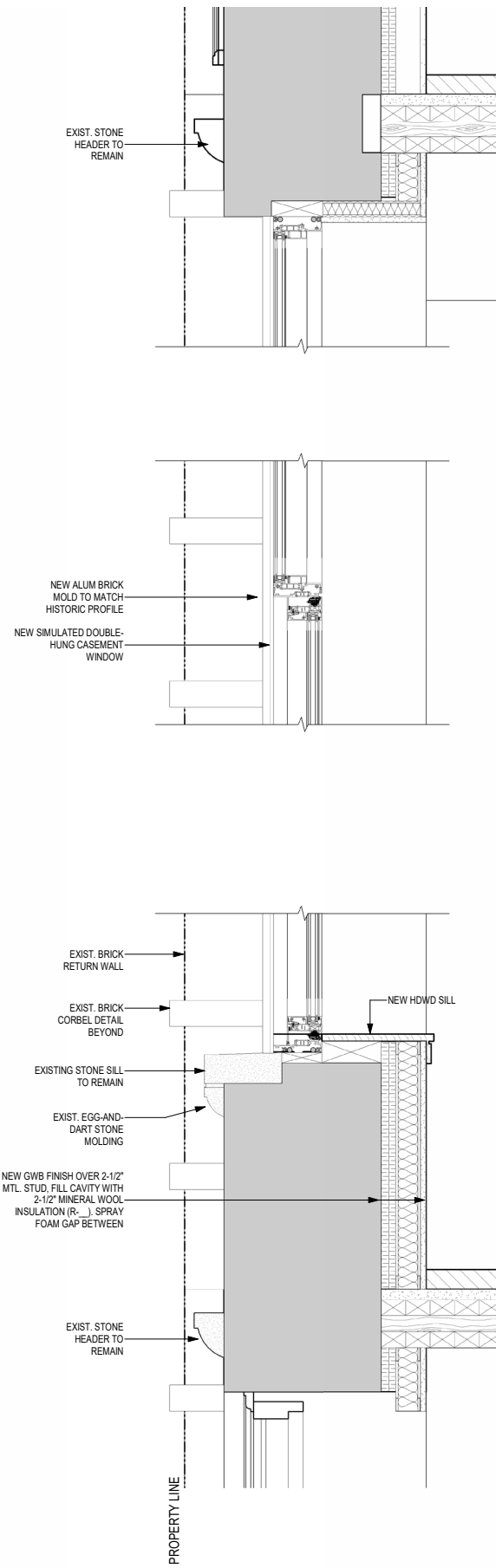

② PROPOSED SIMULATED DOUBLE-HUNG WINDOW
1 1/2" = 1'-0"

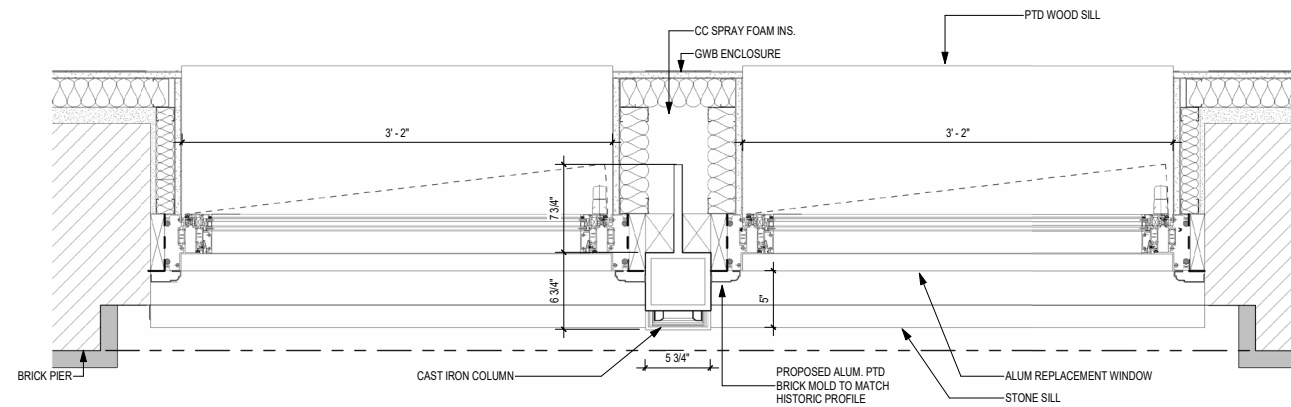

⑦ TYPICAL WINDOW PLAN PROPOSAL
1 1/2" = 1'-0"

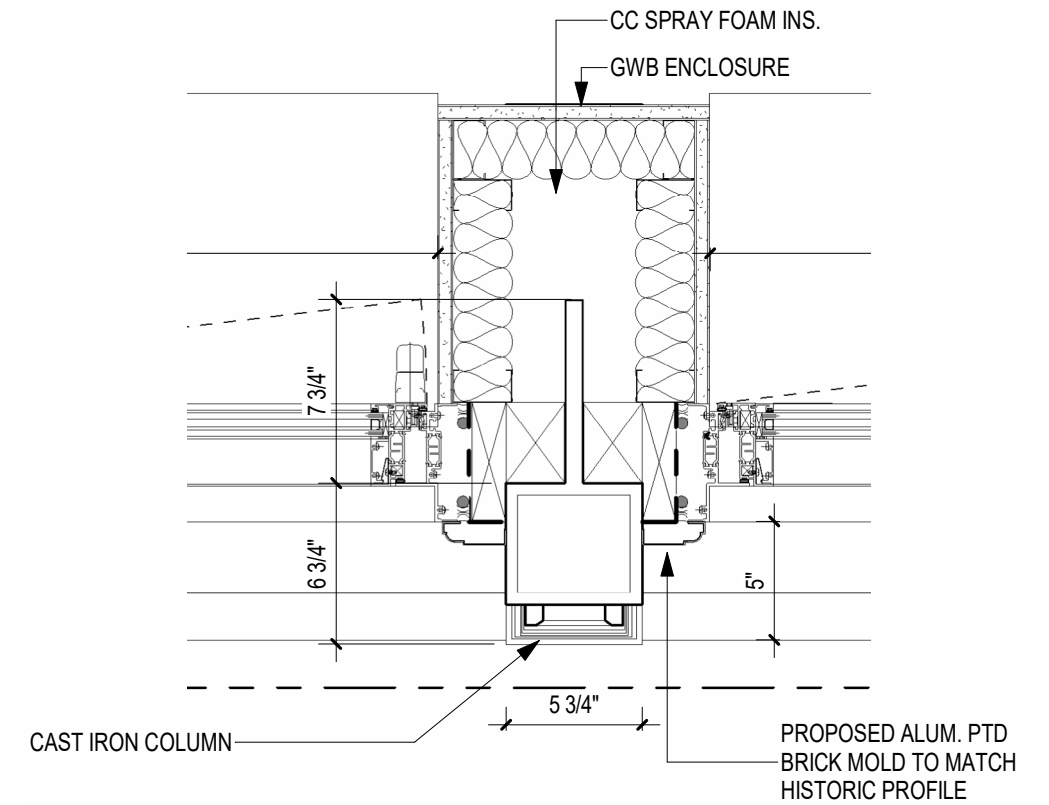

CAST IRON COLUMN AND WINDOW DETAIL



RENDERED VIEW



ENLARGED RENDERED VIEW



ENLARGED MOCK-UP PHOTO

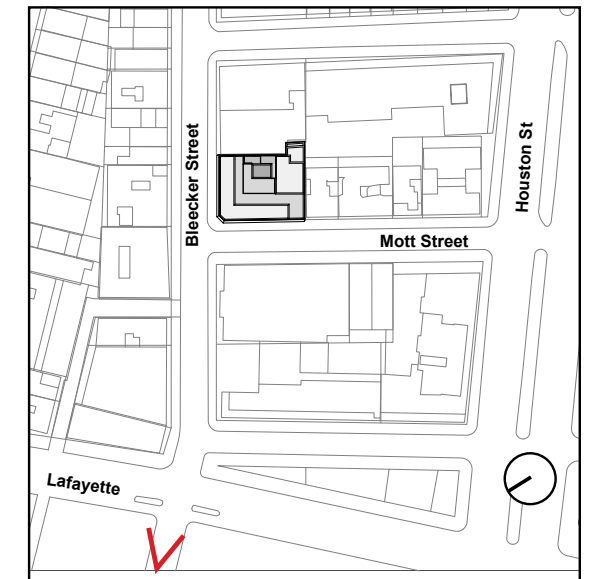



RENDERED VIEW



ENLARGED RENDERED VIEW



ENLARGED MOCK-UP PHOTO

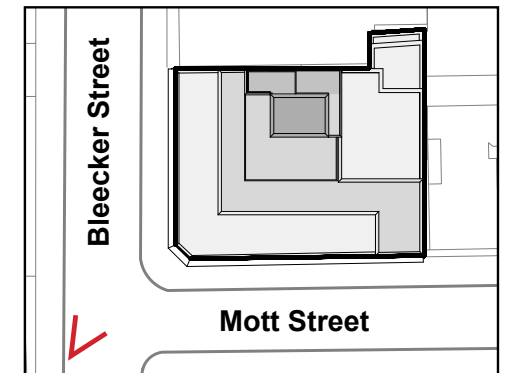



RENDERED VIEW

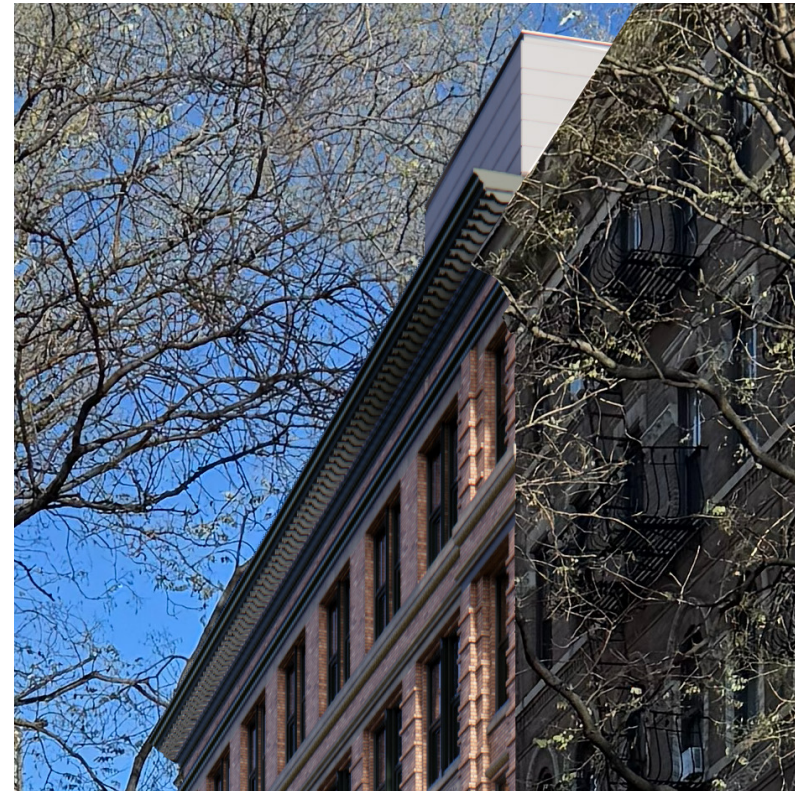

ENLARGED RENDERED VIEW



ENLARGED MOCK-UP PHOTO

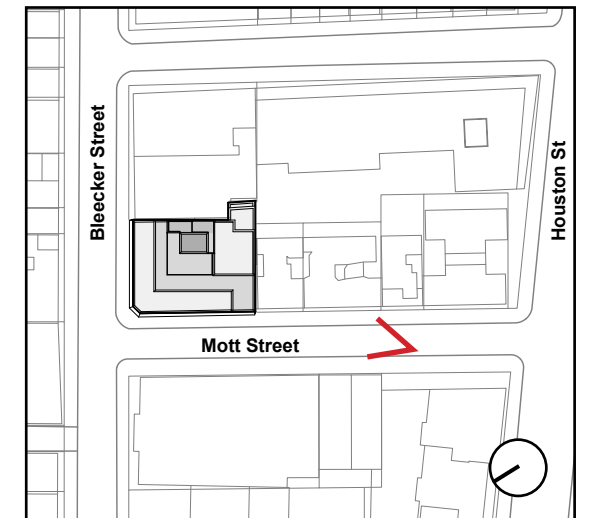



RENDERED VIEW



ENLARGED RENDERED VIEW



ENLARGED MOCK-UP PHOTO

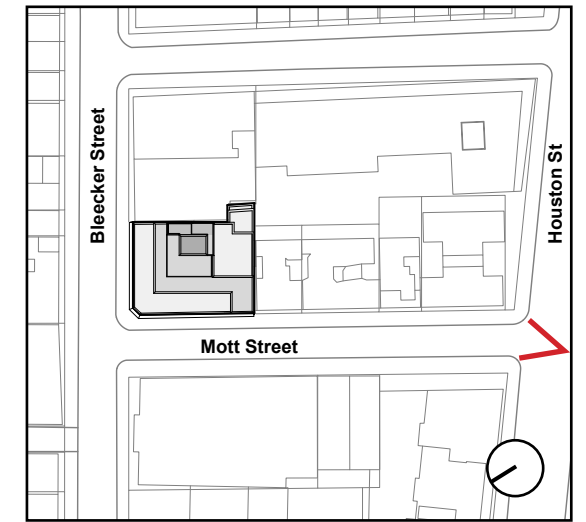



RENDERED VIEW

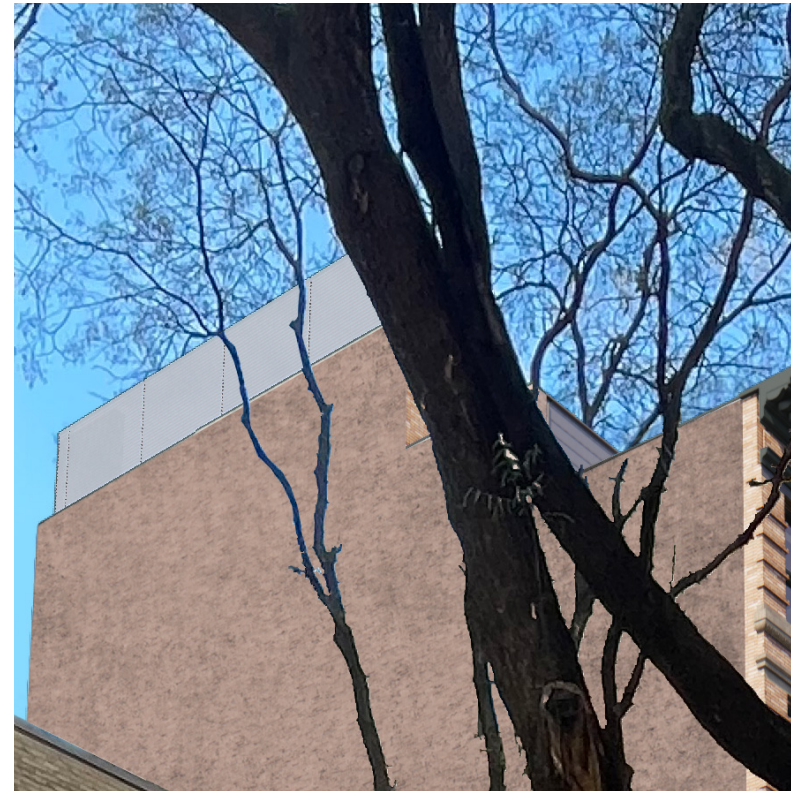

ENLARGED RENDERED VIEW



ENLARGED MOCK-UP PHOTO

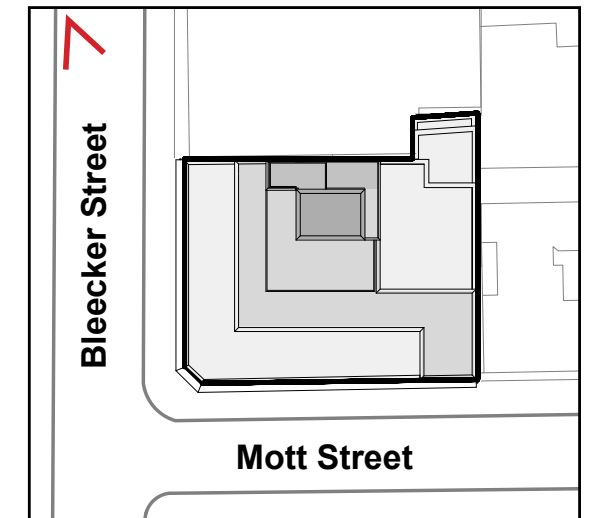



RENDERED VIEW



ENLARGED RENDERED VIEW



ENLARGED MOCK-UP PHOTO

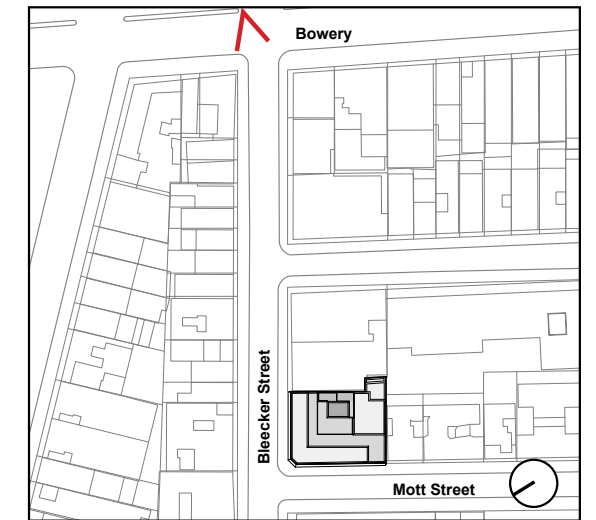

BUILDING MATERIALS

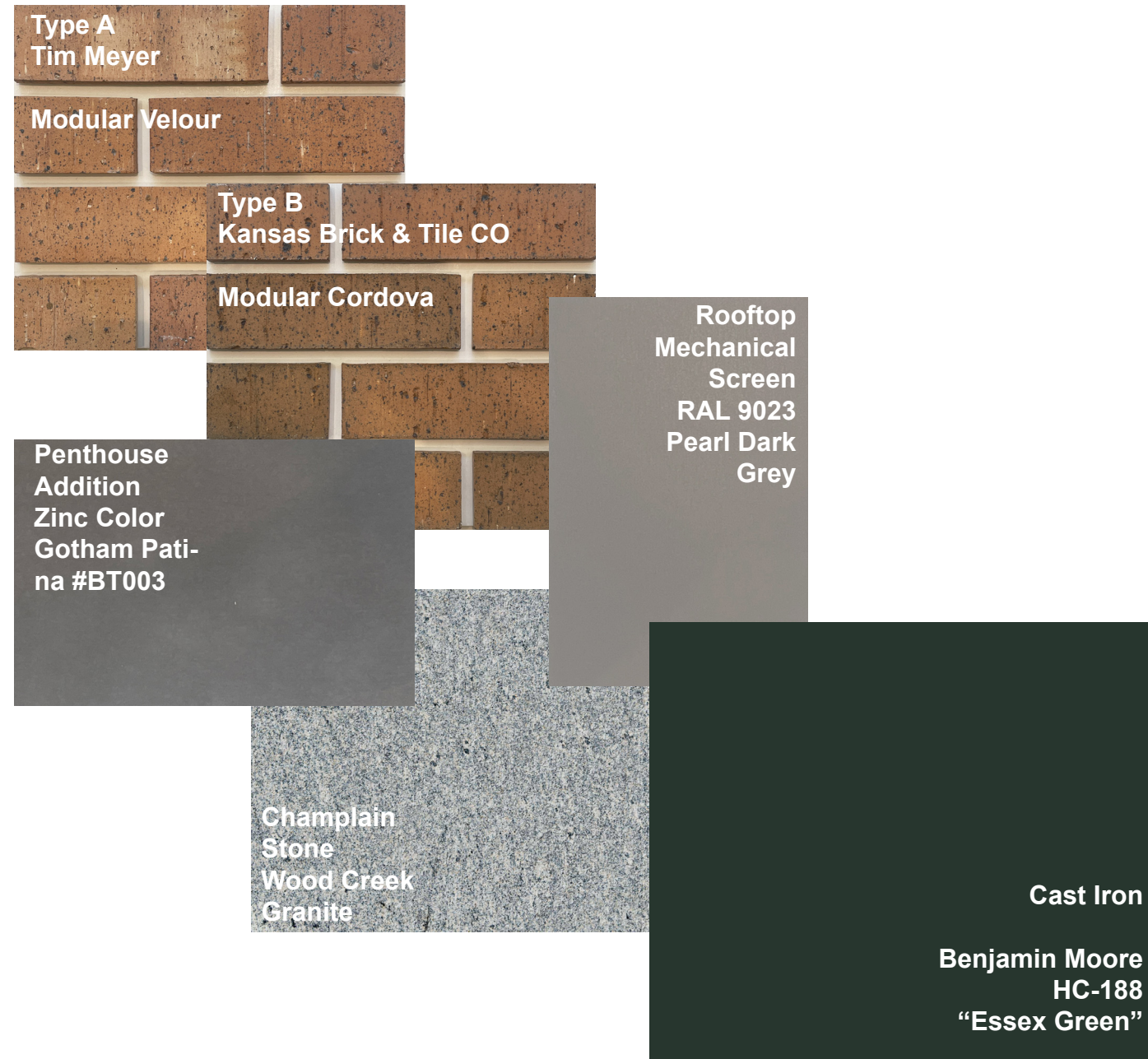



BRICK PIER ELEVATION

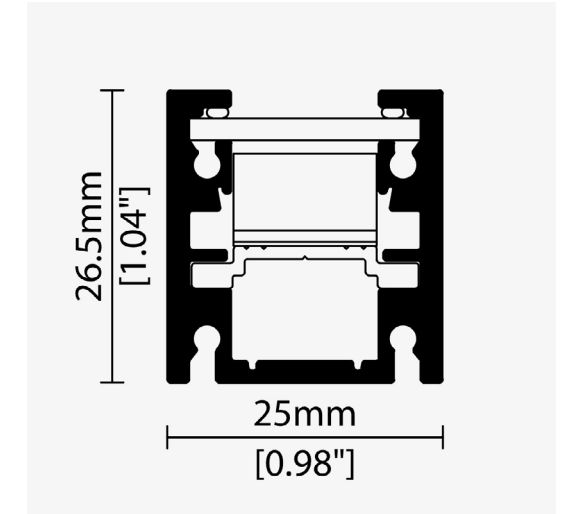
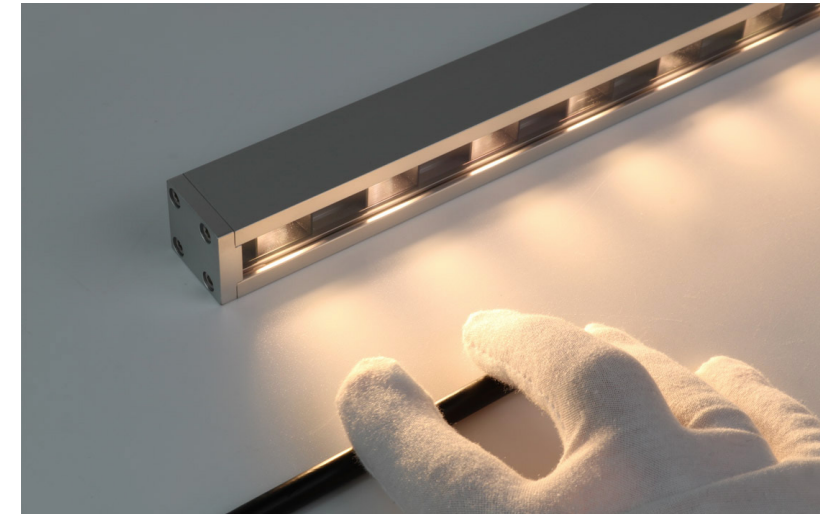

KKDC MOMO POWER GRAZING UPLIGHT MTG DETAIL

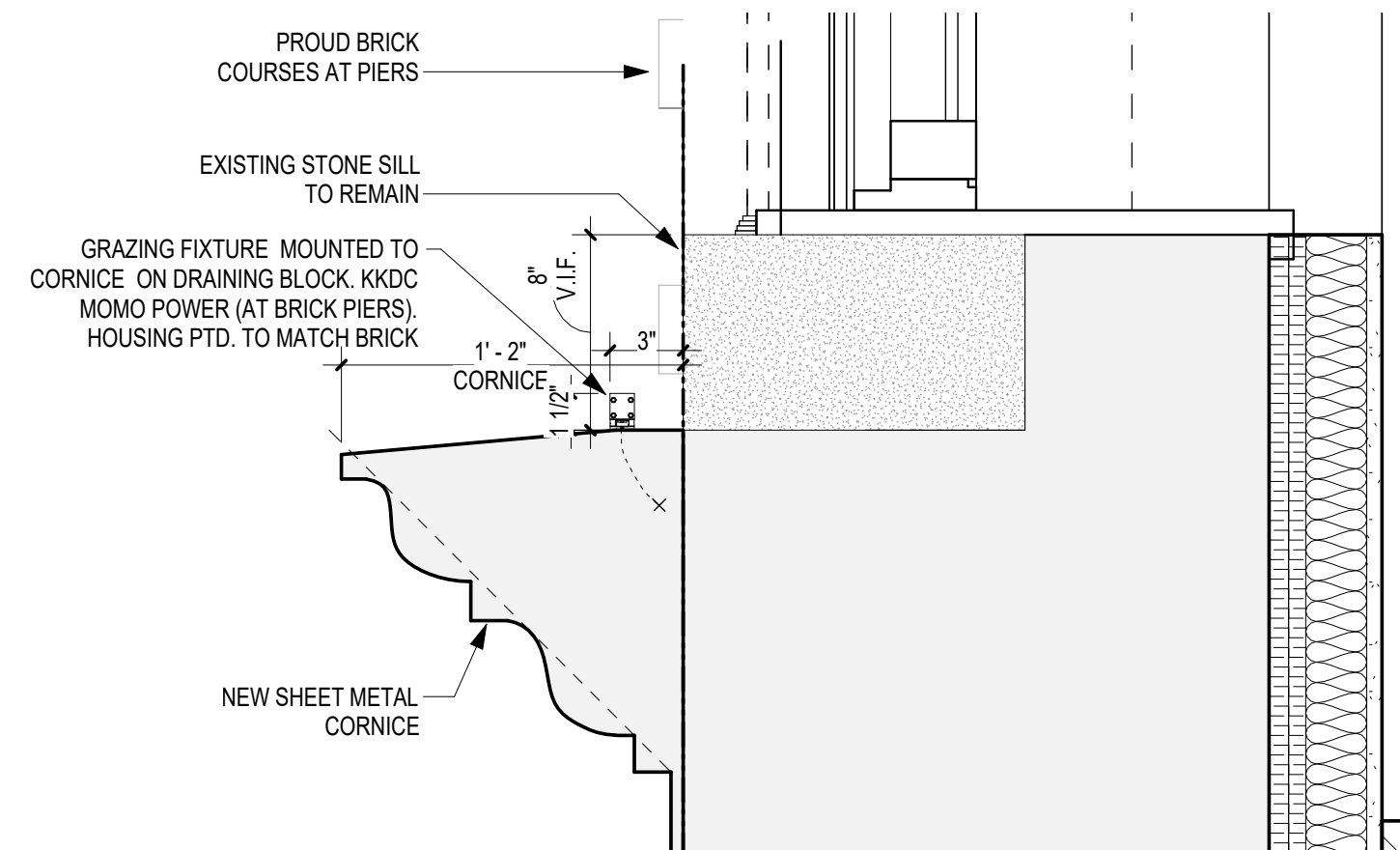

GRAZING LIGHT FIXTURE AT BRICK PIERS

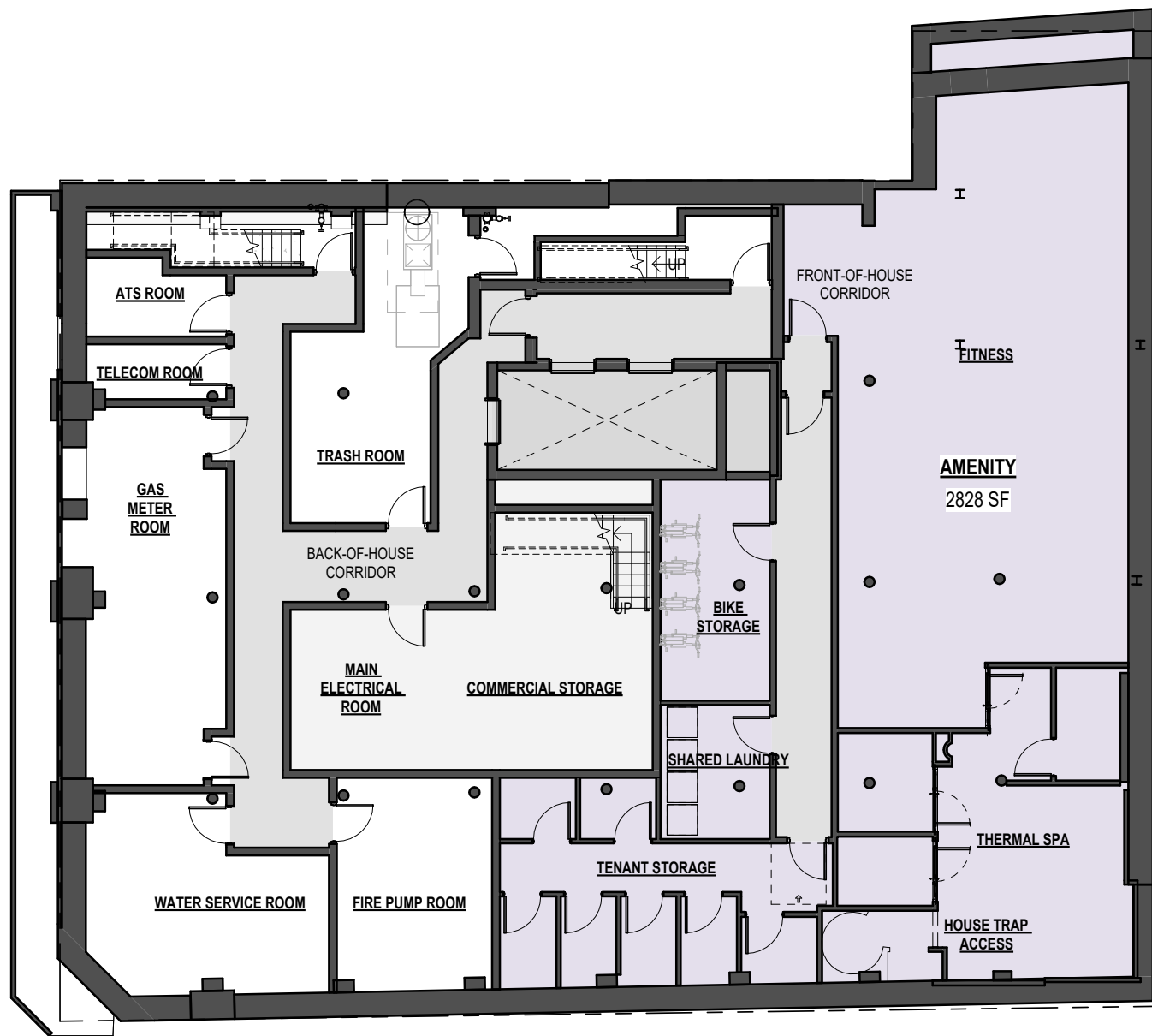

CELLAR

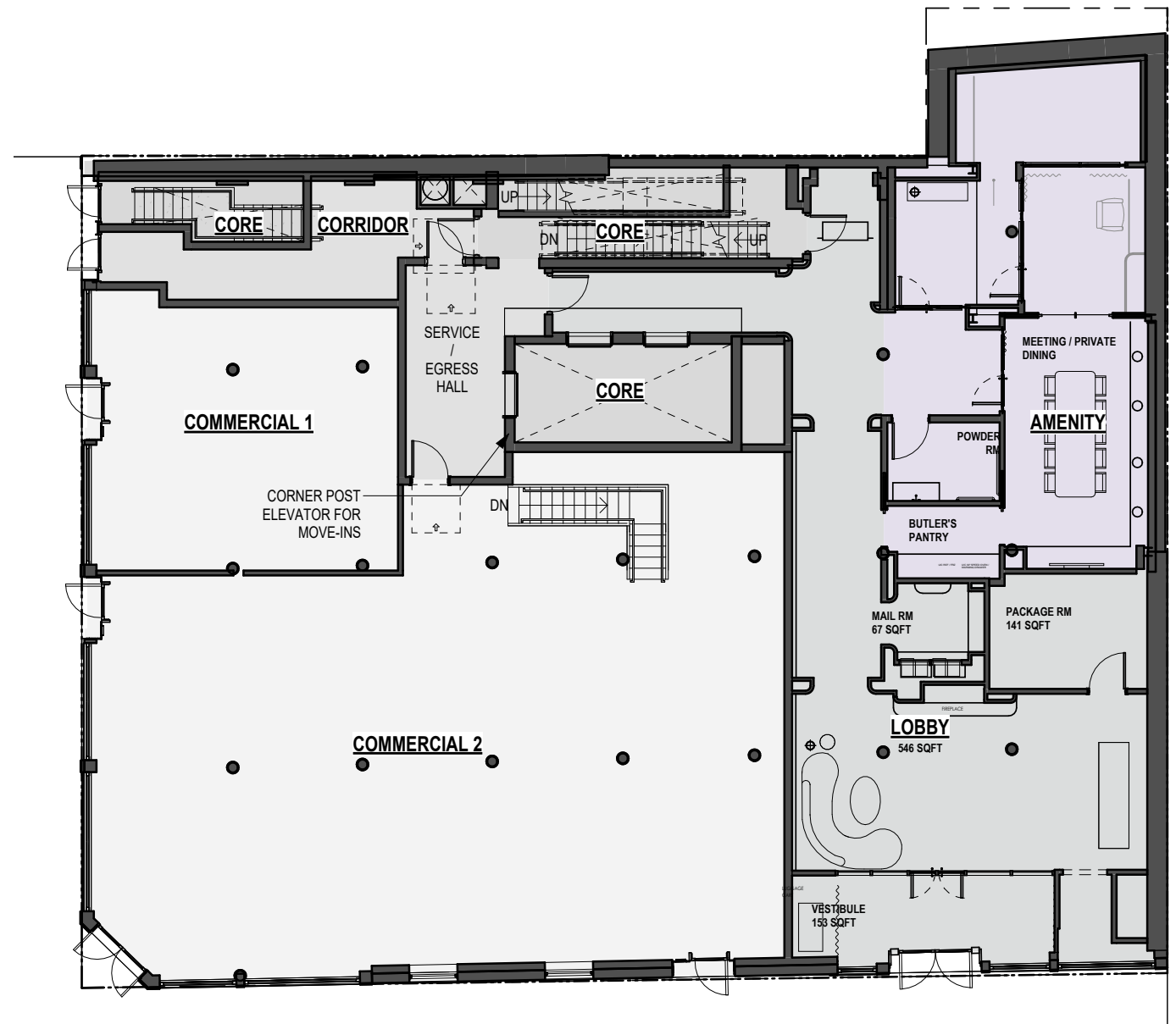

GROUND FLOOR

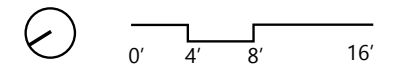

CELLAR & GROUND FLOOR PLANS

26 BLEECKER STREET

June 2, 2026

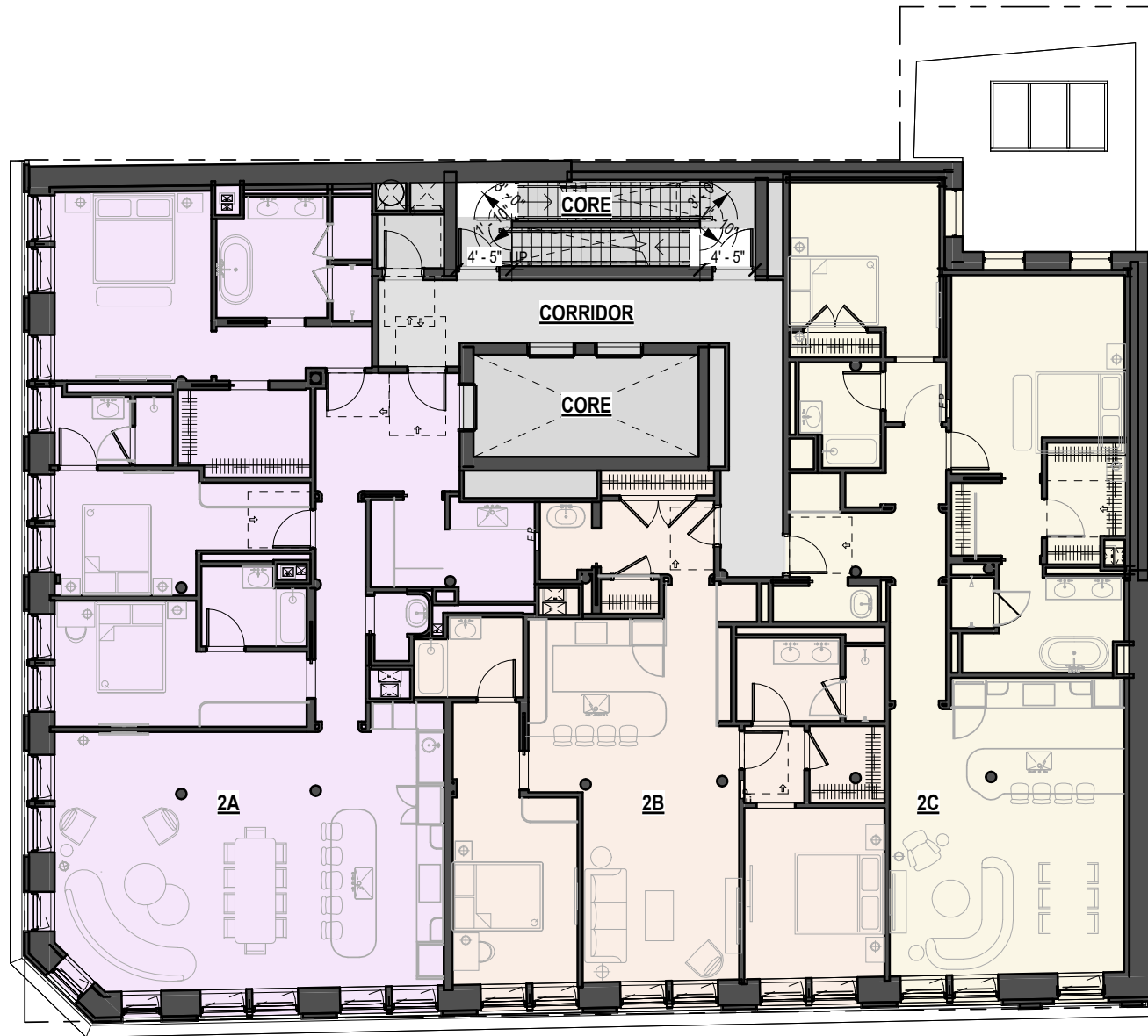

2ND-4TH FLOOR

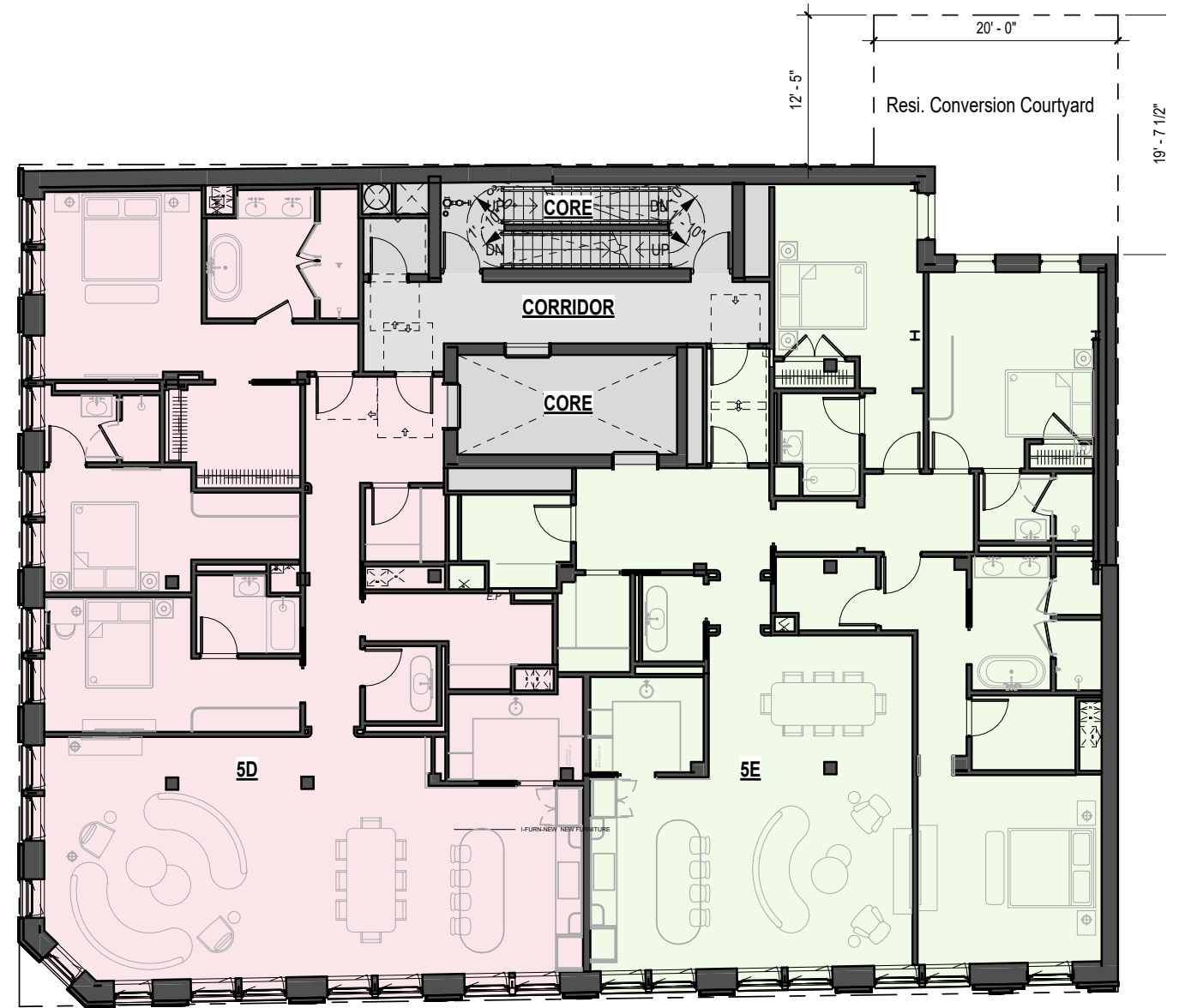

5TH & 6TH FLOOR



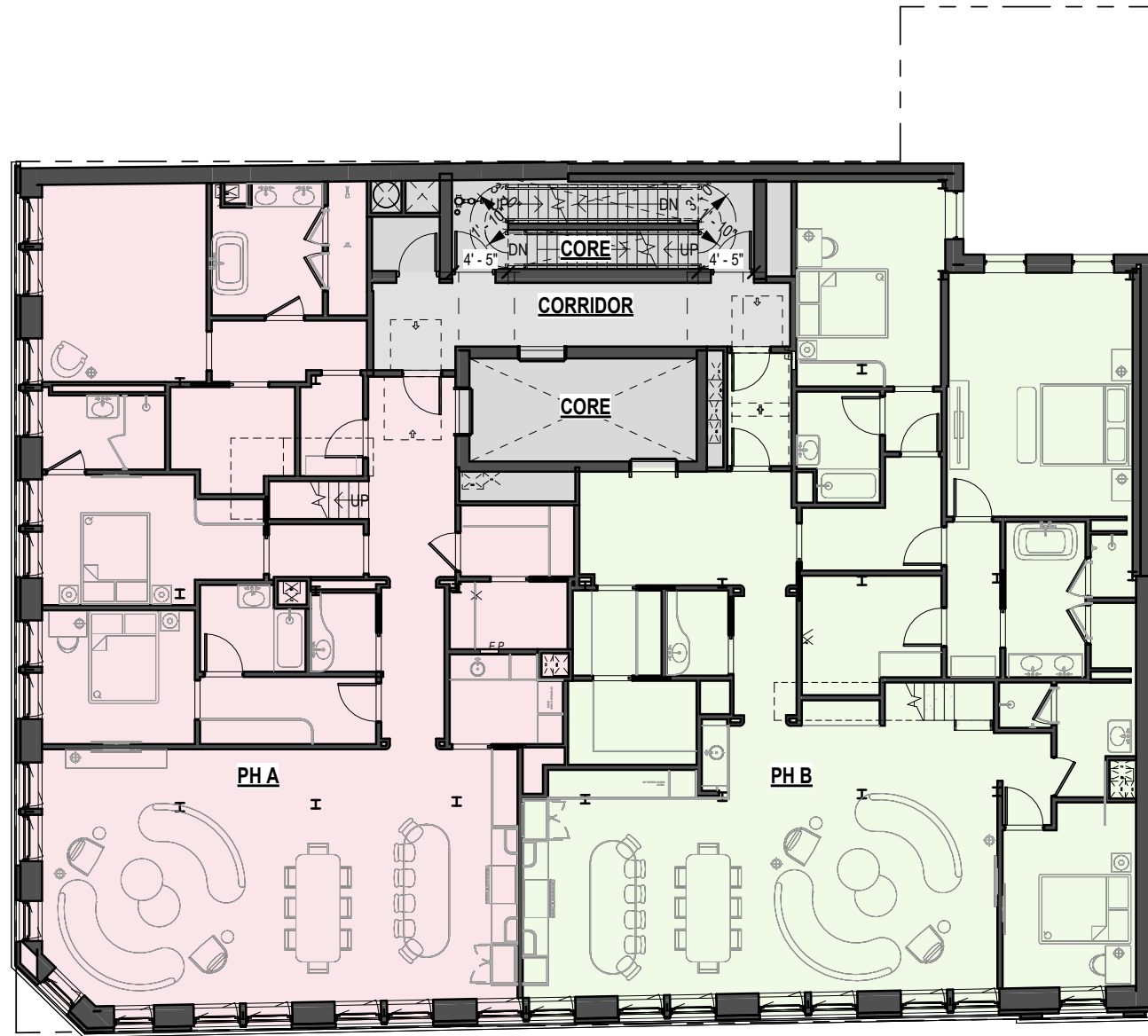

7TH FLOOR

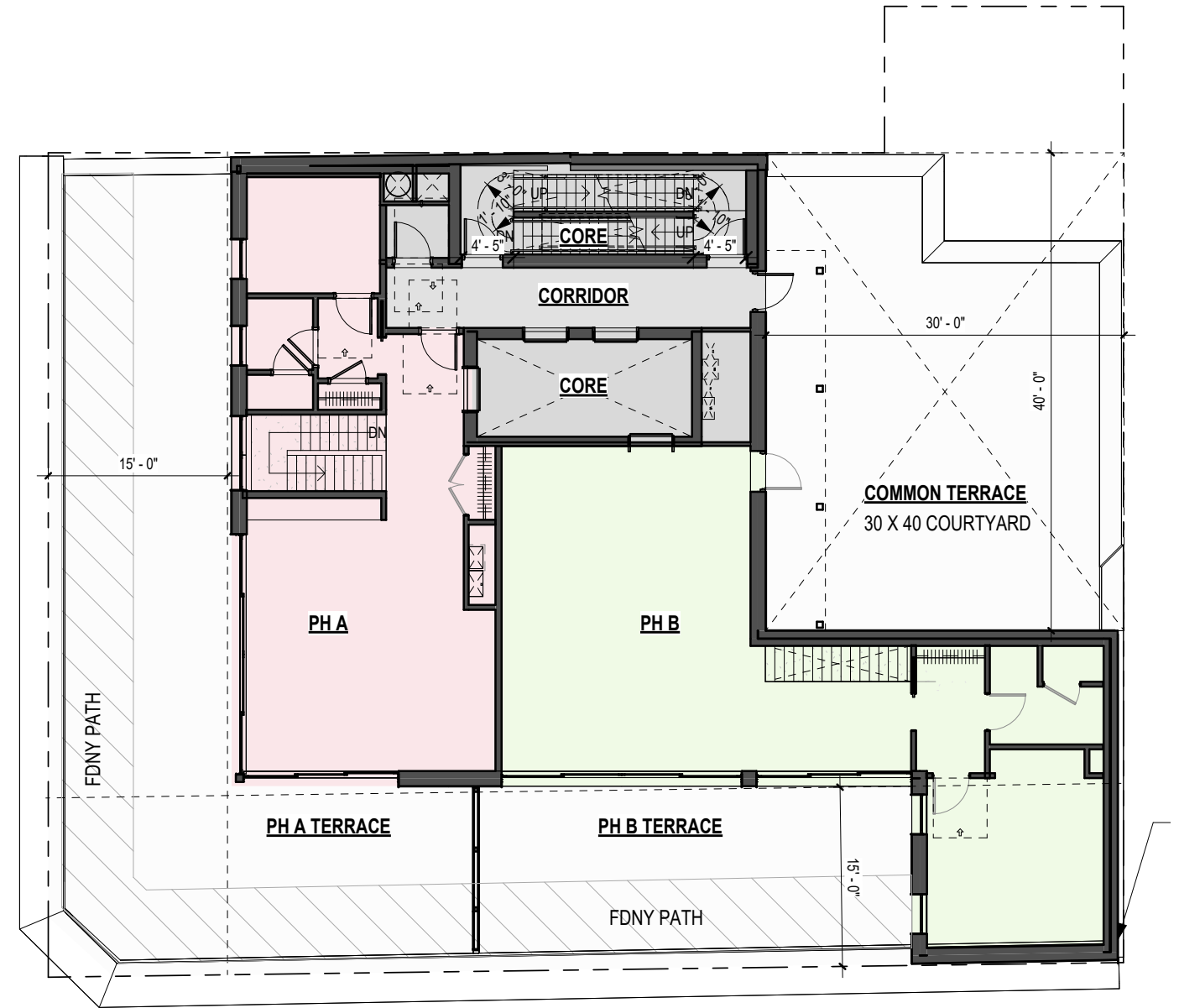

PENTHOUSE

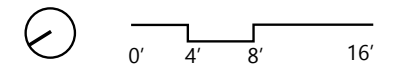

PENTHOUSE FLOOR PLANS

26 BLEECKER STREET

June 2, 2026

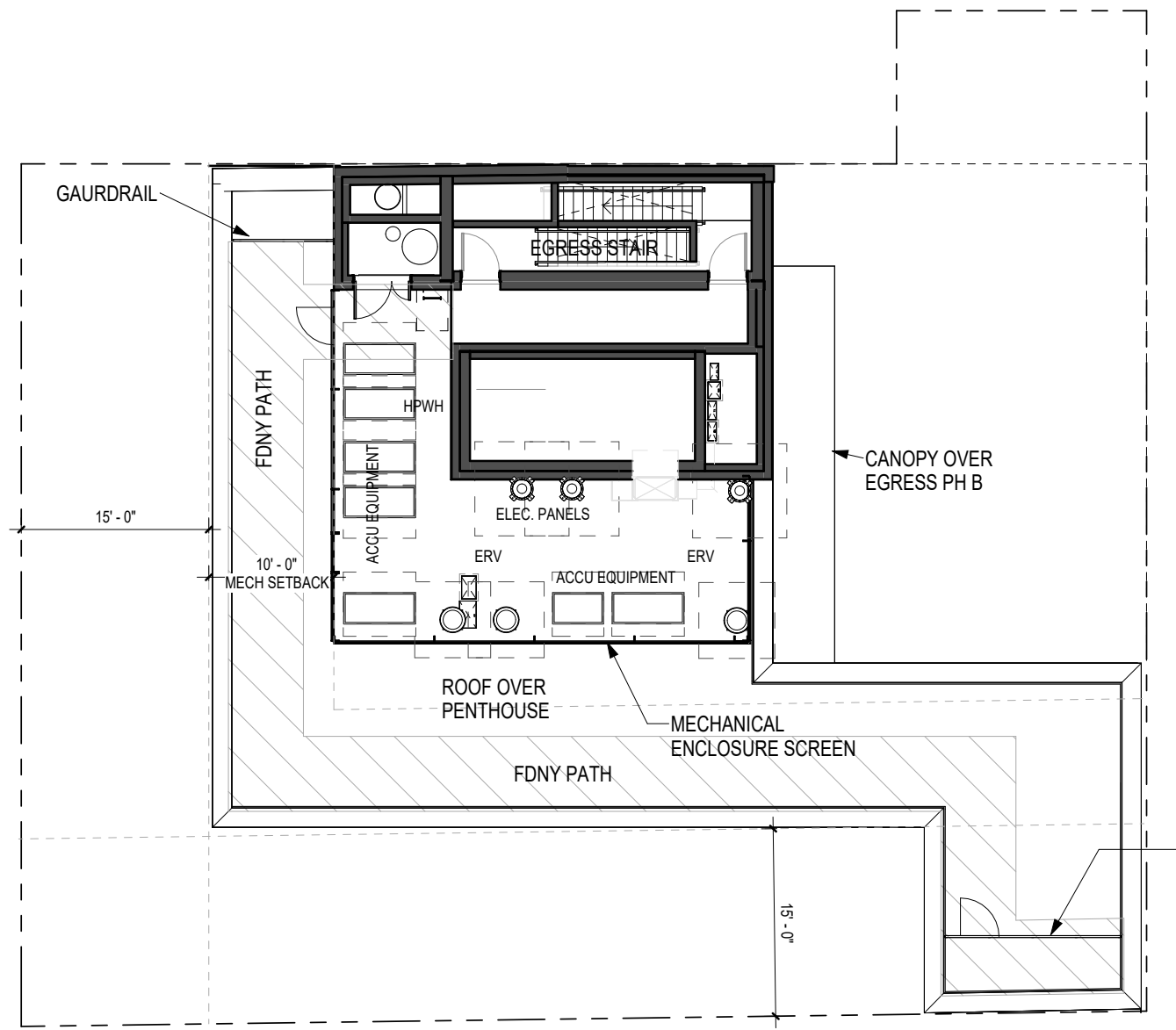

ROOF

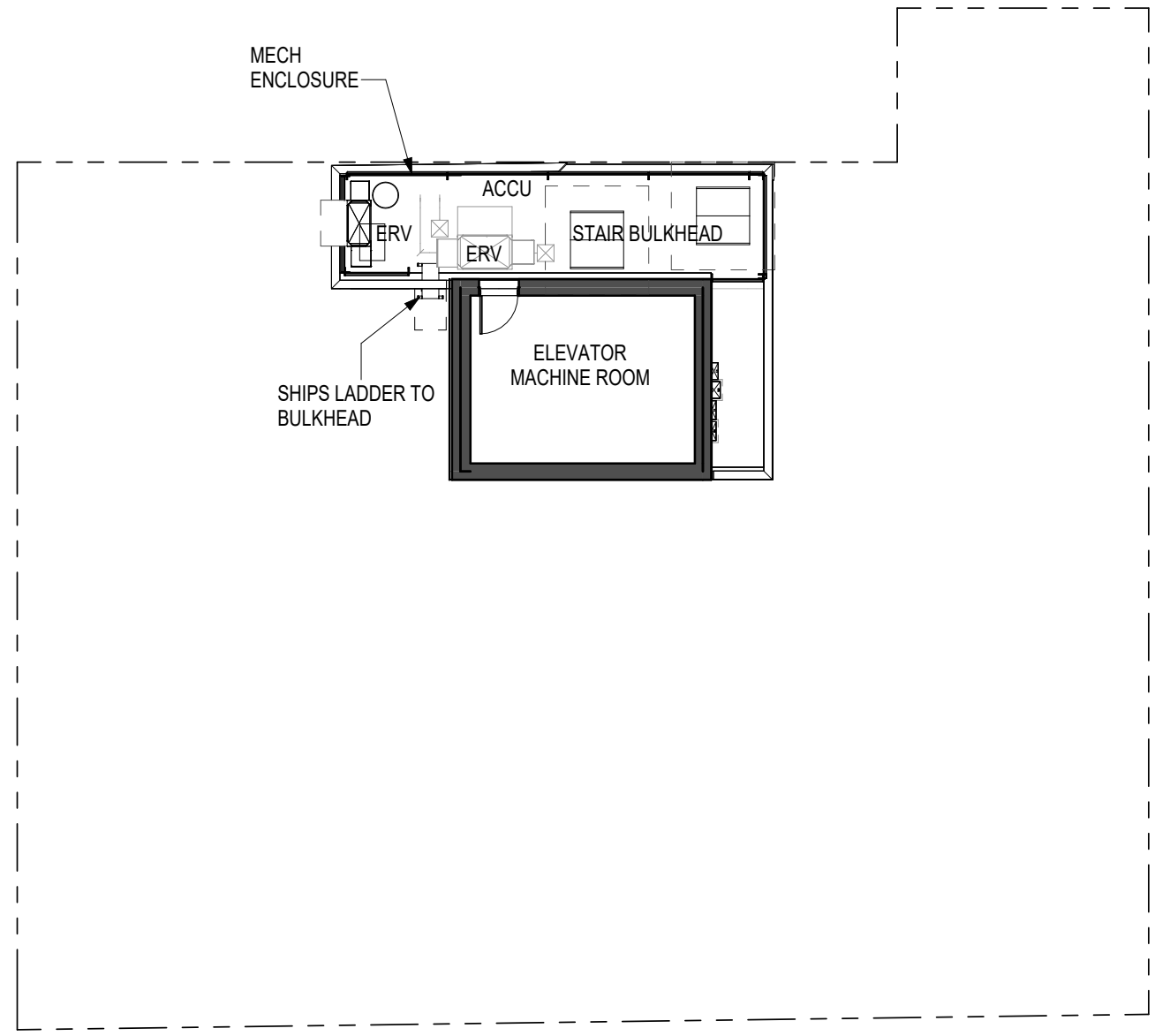

BULKHEAD

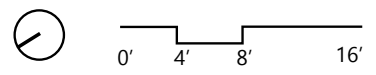

ROOF AND BULKHEAD PLAN

June 2, 2026
Public Hearing

The current proposal is:

Preservation Department – Item 7, LPC-26-10511

26 Bleecker Street – Noho East Historic District Borough of Manhattan

To testify virtually, please join Zoom

Webinar ID: 165 104 6126

Passcode: 717488

By Phone: 646-828-7666 (NY)

833-435-1820 (Toll-free)

833-568-8864 (Toll-free)

Note: If you want to testify virtually on an item, join the Zoom webinar at the agenda's "Be Here by" time (about an hour in advance). When the Chair indicates it's time to testify, "raise your hand" via the Zoom app if you want to speak (*9 on the phone). Those who signed up in advance will be called first.



**NOHO EAST HISTORIC DISTRICT - DESIGNATION REPORT
MAY 11, 2010**

26-30 BLEECKER STREET (Southeast corner of Bleecker Street and Mott Street) aka 318-320 Mott Street
 Borough of Manhattan Tax Map Block 521, lot 37
 Date of construction: 1900-01 (NB 547-1900)
 Architect: Louis F. Heinicke
 Original Owner: Vincent Minnerly
 Type: Store and lofts
 Style: Classical Revival
 Stories: 7
 Structure/material: Steel/brick and terracotta

Features: Bleecker Street. Six bays with one-bay chamfered corner; paired fenestration with historic cast-iron columns; one-story base featuring non-historic, molded terra-cotta bulkhead, historic cast-iron columns, non-historic brick and glass infill; non-historic, metal entryway doors and grilled transoms; non-historic lights and security cameras; upper stories feature historic coursed brick piers, window sills set in a continuous band, terra-cotta window lintels with egg-and-dart decoration, and terra-cotta spandrels with decorative cartouches and flourishes; non-historic, one-over-one metal sash; non-historic flagpoles and banner; non-historic, brick roof parapet. Mott Street. Eight bays; similar to Bleecker Street facade; non-historic, one-over-one metal sash; windows at elevator shaft sealed with non-historic masonry and cement stucco. East elevation. Brick and non-historic cement stucco; lot-line windows with non-historic, one-over-one wood sash. Roof. Non-historic, cement-stucco-covered elevator bulkhead.

History: This Classical Revival-style store-and-loft building was designed by architect Louis F. Heinicke and built in 1900-01 for owner Vincent Minnerly at a time when the area was becoming increasingly commercial in character and many of the older dwellings were being converted to commercial use or replaced with new loft buildings. It replaced four existing buildings. Nothing is known about the architect except that he maintained an office in Manhattan for one year beginning in 1900. The building originally had a one-story corner tower and a roof cornice, which were removed between c.1939 and c.1988, possibly during a major rehabilitation in 1990-91. For much of its history, this building was occupied mainly by clothing manufacturers, furriers, and printers; these industries had a strong presence in the NoHo East area. The building houses several very long-standing tenants, including S.B Shulman Printing (c.1930-55), Tompkins Press (c.1930-80), Century Printing Co. (c.1930-80), Greenwich Envelope Co. (c.1930-80), Salisbury Press (c.1935-50), Blumencranz Bros. Glass Inc. (c.1935-60), the Rennee Footwear Co. (c.1940-60), and the W & M Headwear Co. (c.1965-80). The 1990-91 conversion was performed by Planned Parenthood of New York City, which leased the building in 1989, for use as its headquarters. Its parent organization, Planned Parenthood of America, a non-profit organization devoted to reproductive health care, is the oldest and largest of its kind in the United States, having been founded in 1939 as the Birth Control Federation of America. Among its forerunners was the country's first birth-control clinic, opened in Brooklyn in 1916 by Margaret Sanger (1879-1966). In 1952, she helped form the International Planned Parenthood Federation. The intersection of Bleecker and Mott Streets in front of the Planned Parenthood of New York City offices has been renamed "Margaret Sanger Square" in her honor. This is one of the few buildings in the historic district that remains in commercial use. The building, which is largely intact to its early-twentieth-century appearance, contributes to the mixed-use and diverse architectural character of the NoHo East Historic District.

Significant Alterations:

- 1916 (ALT 3564-1916): A water tank was installed on the roof. Owner: Emma Schalk (181 Broadway).
- c.1939-c.1988: The original one-story corner tower and roof cornice were removed, possibly during a major rehabilitation in 1985-86.
- 1965 (ALT 1749-1965): New masonry and glass storefronts were installed. The building was occupied as a factory. Owner: Javker Realty Corp. (50 Bond Street); lessee: Paramount Apparel, Ltd.; architect: Larry Meltzer (188 Montague Street, Brooklyn).
- 1990-91: Major interior alteration and installation of a new first-story facade.



30% LIGHTER MIX



70% DARKER MIX



RENDERED VIEW



ENLARGED RENDERED VIEW



ENLARGED MOCK-UP PHOTO

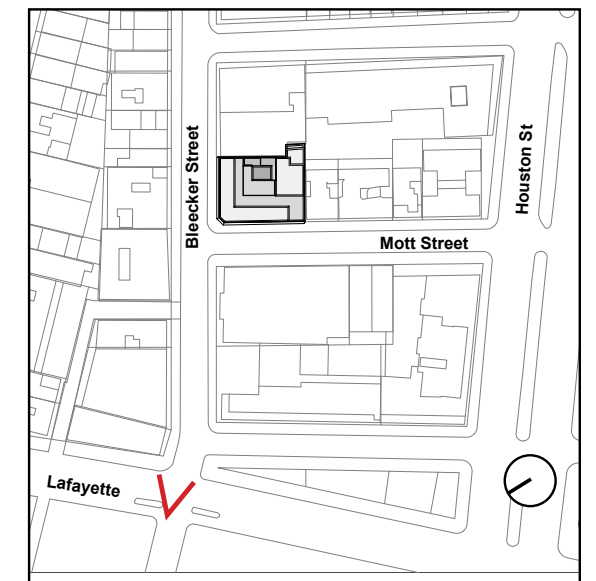



1



2

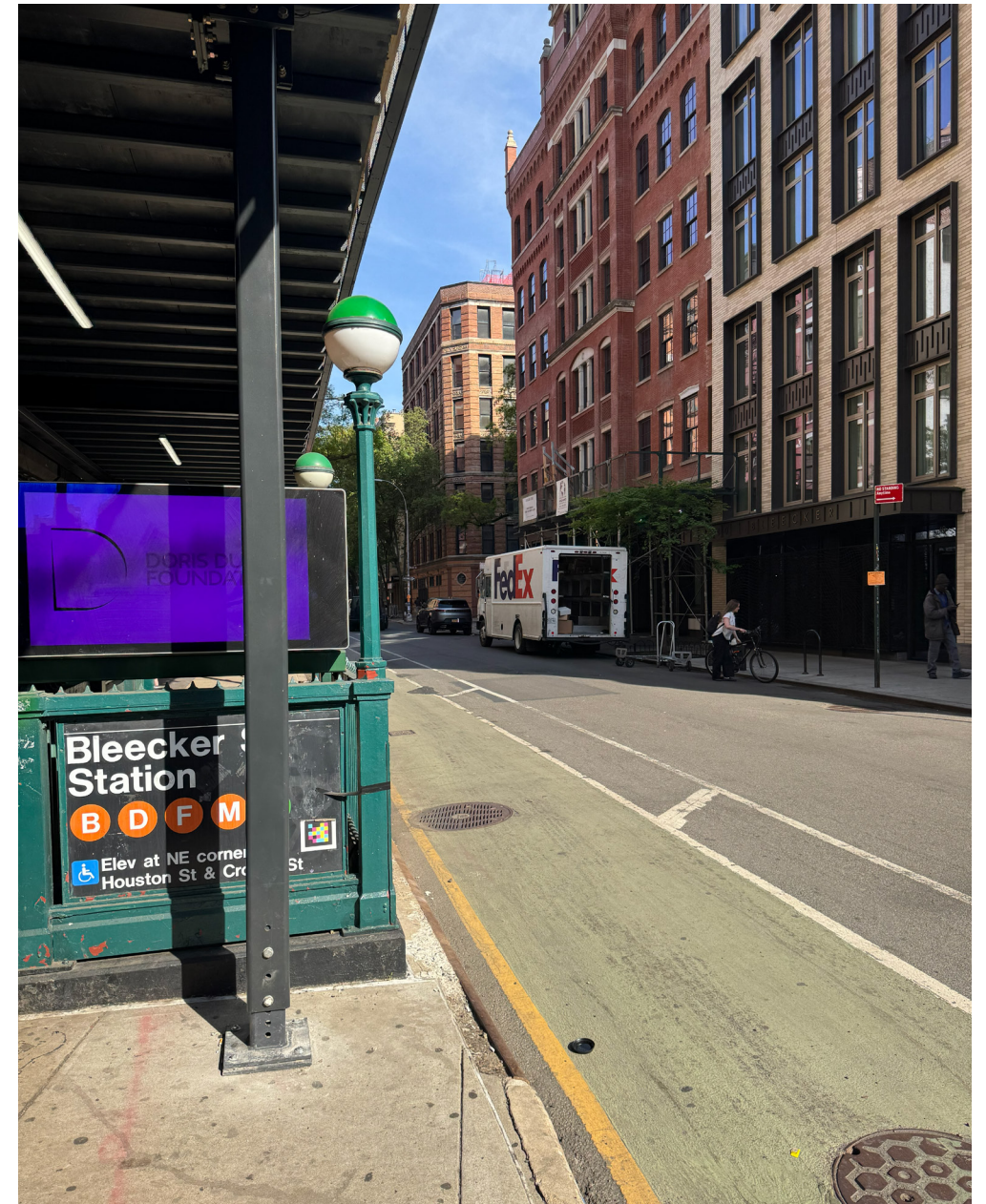

3

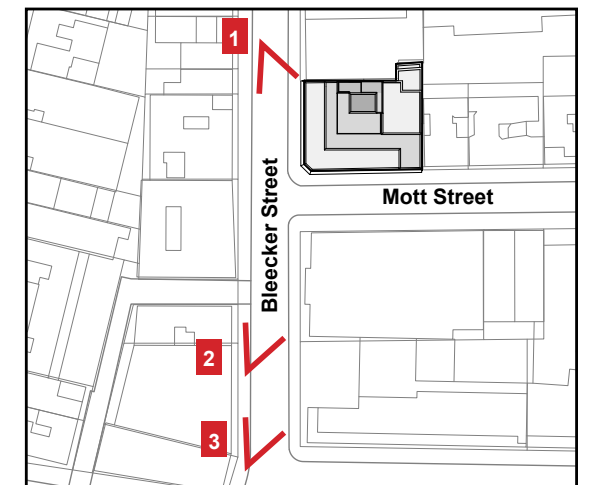



REPLACEMENT WINDOW OPERATION



EXISTING WEIGHT & CHAIN BOXES



WOOD BRICK MOULD BE-
NEATH ALUMINUM MOULD

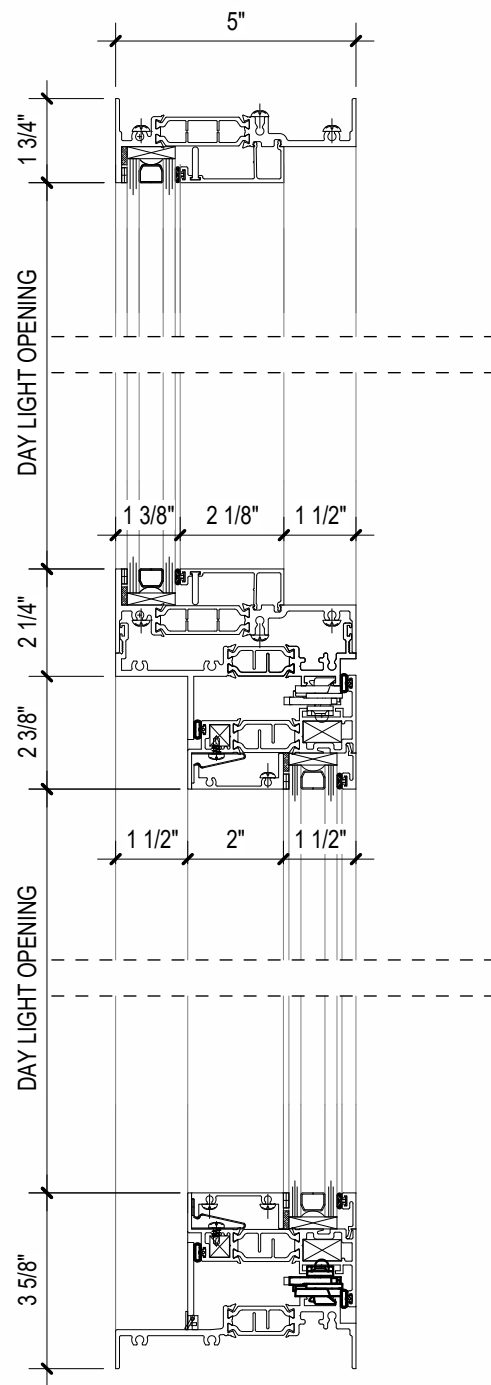

1 Window Section Detail
 3" = 1'-0"

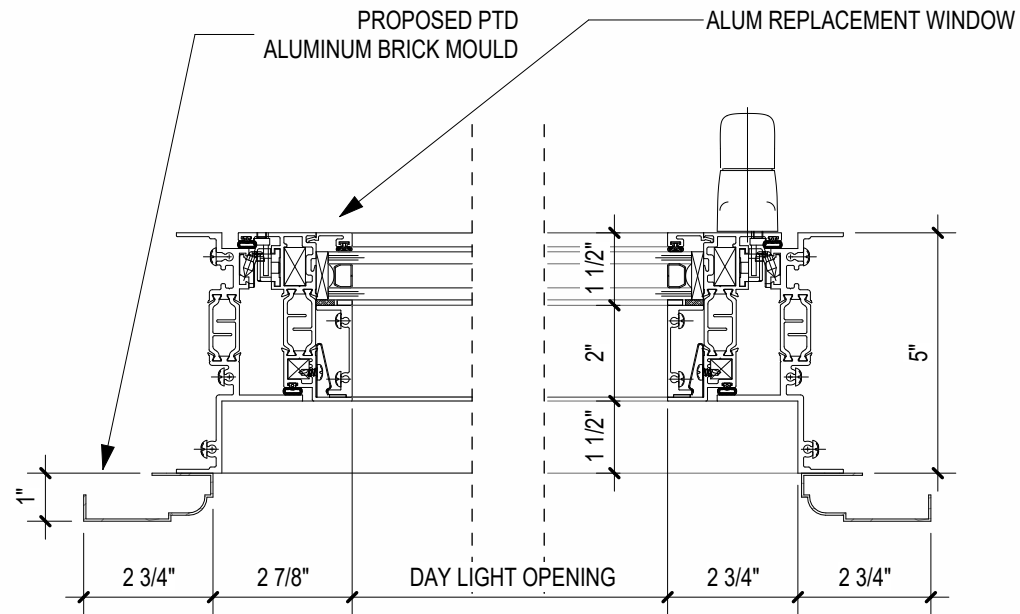

2 Window Plan Detail
 3" = 1'-0"

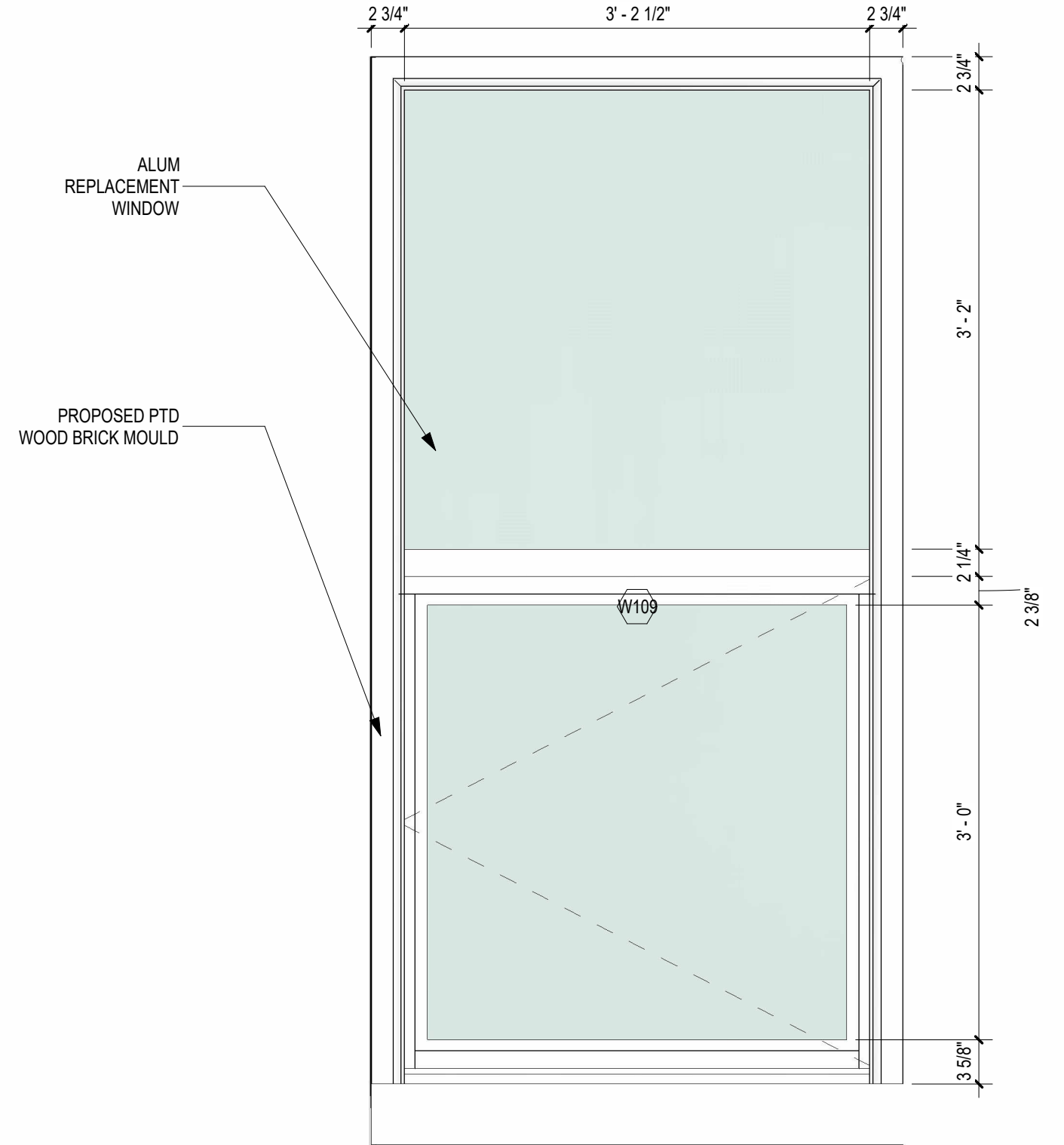

3 PROPOSED DOUBLE-HUNG WINDOW ELEVATION DETAIL
 1" = 1'-0"



SIMULATED DOUBLE-HUNG CASEMENT
ARCHITECTURAL WINDOW 3400 SERIES

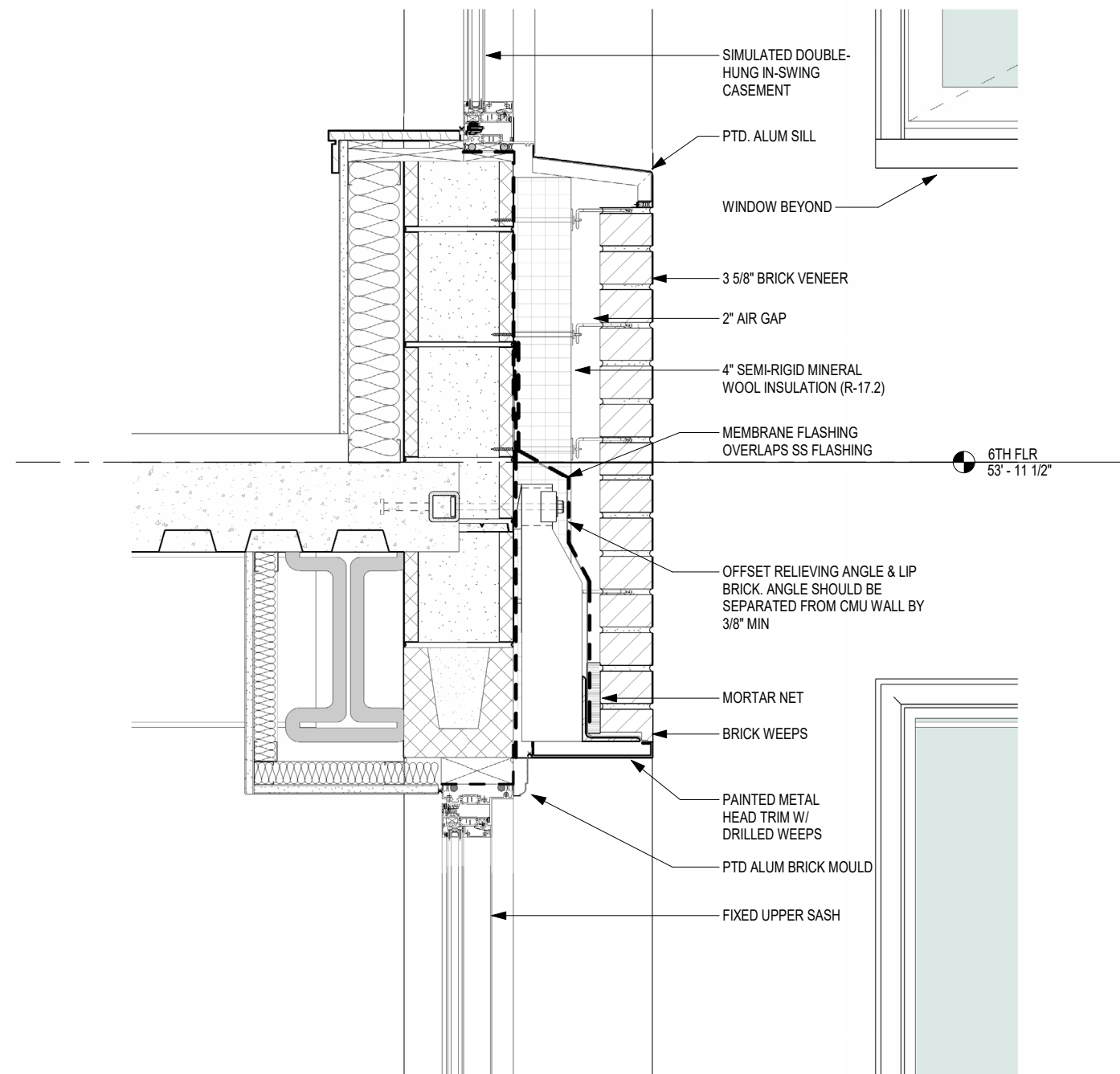

① EAST COURTYARD DETAIL AT WINDOW
 1 1/2" = 1'-0"

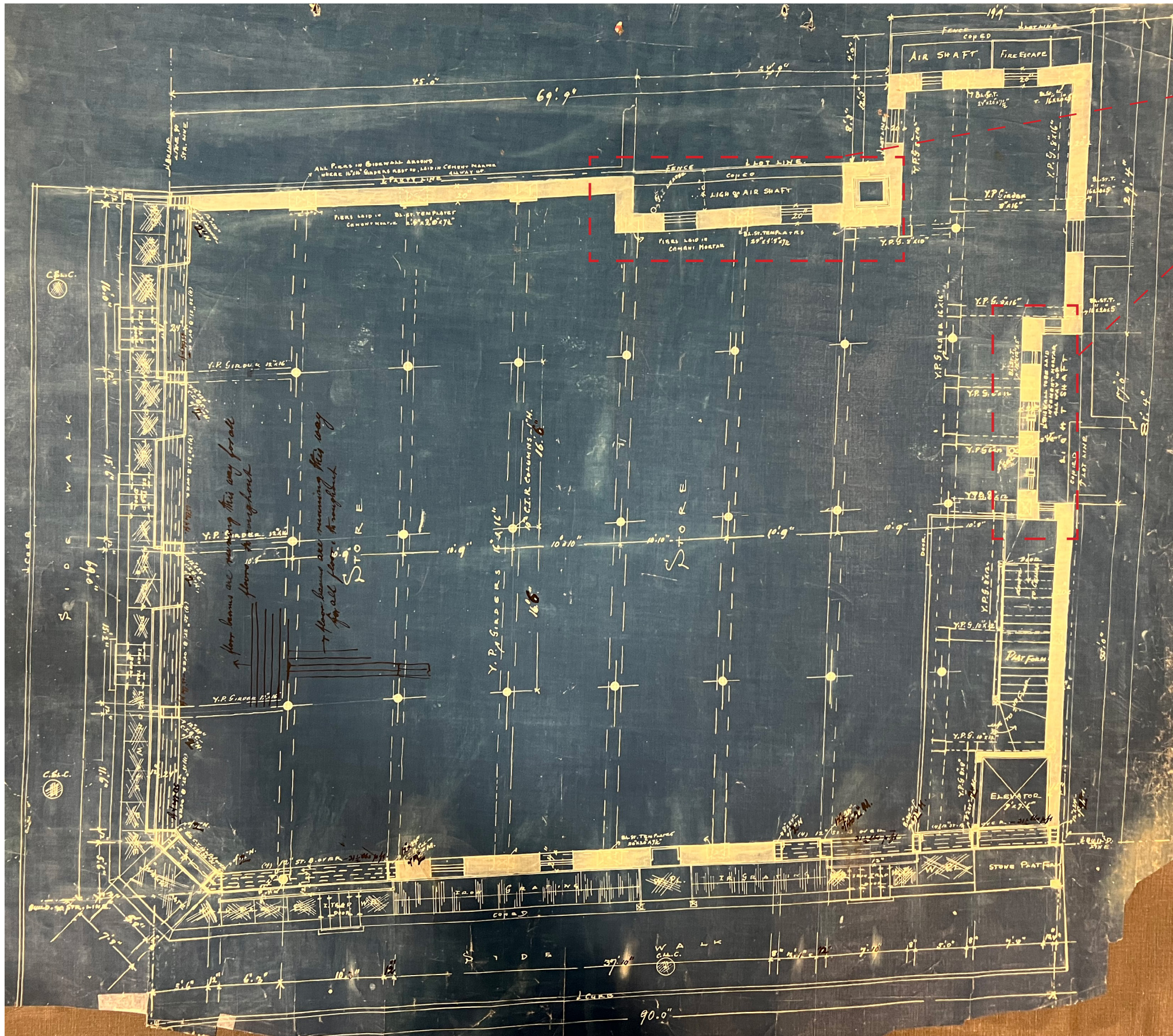

Existing light shafts to be filled in

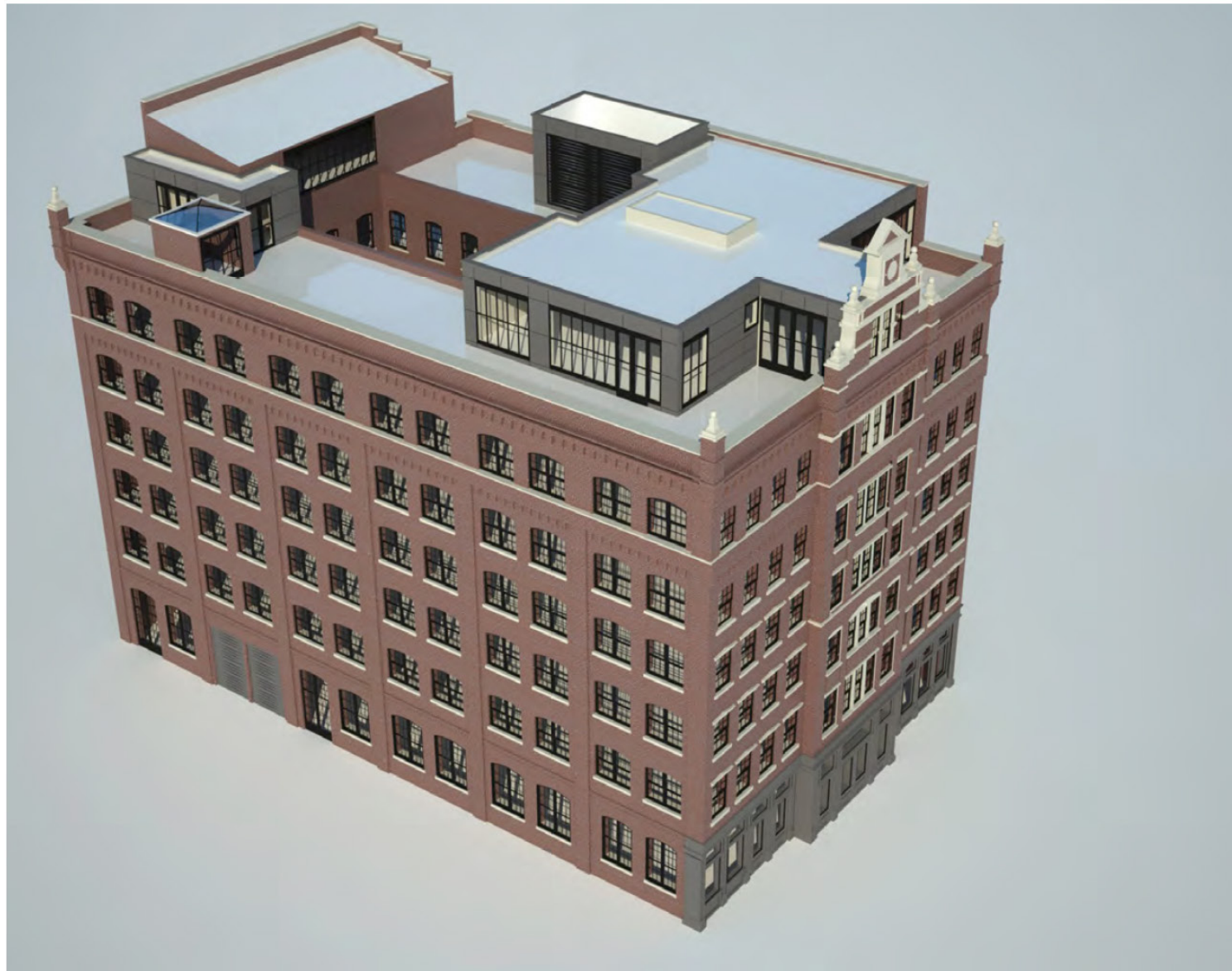

1. AERIAL VIEW FROM NORTHEAST



2. AERIAL VIEW FROM NORTHWEST

36 Bleecker Street, 2012 LPC Approval (Morris Adjmi)



EXISTING BUILDING ELEVATION



PROPOSED BUILDING ELEVATION



PROPOSED BUILDING RENDERING

03.14.2019 | SHEET NAME: ELEVATIONS | PROJECT NAME: 11 BOND STREET | MARIN ARCHITECTS

03.14.2019 | SHEET NAME: PERSPECTIVE | PROJECT NAME: 11 BOND STREET | MARIN ARCHITECTS

11 Bond Street , NoHo Historic District , 2016 and 2019 LPC Approvals (Marin Architects)

June 2, 2026
Public Hearing

The current proposal is:

Preservation Department – Item 7, LPC-26-10511

26 Bleecker Street – Noho East Historic District Borough of Manhattan

To testify virtually, please join Zoom

Webinar ID: 165 104 6126

Passcode: 717488

By Phone: 646-828-7666 (NY)

833-435-1820 (Toll-free)

833-568-8864 (Toll-free)

Note: If you want to testify virtually on an item, join the Zoom webinar at the agenda's "Be Here by" time (about an hour in advance). When the Chair indicates it's time to testify, "raise your hand" via the Zoom app if you want to speak (*9 on the phone). Those who signed up in advance will be called first.