

June 2, 2026
Public Hearing

The current proposal is:

Preservation Department – Item 4, LPC-26-06032

19 Cranberry Street – Brooklyn Heights Historic District Borough of Brooklyn

To testify virtually, please join Zoom

Webinar ID: 165 104 6126

Passcode: 717488

By Phone: 646-828-7666 (NY)

833-435-1820 (Toll-free)

833-568-8864 (Toll-free)

Note: If you want to testify virtually on an item, join the Zoom webinar at the agenda's "Be Here by" time (about an hour in advance). When the Chair indicates it's time to testify, "raise your hand" via the Zoom app if you want to speak (*9 on the phone). Those who signed up in advance will be called first.



19 Cranberry Street

LPC Public Hearing
Docket # LPC-26-06032

06.02.26

Colberg.

SCOPE OF WORK, STREET VIEWS, & SITE PLAN

1st Floor: Remove existing bricked in window opening and replace with (2) new double hung windows to match existing.



- 19 Cranberry St**
- Block 214
 - Lot 22
 - Built 1834
 - 4 stories plus cellar
 - Brooklyn Heights Historic District
 - Zoning District R6

Site Plan



Cranberry Street



Cranberry & Willow - Corner View



Rear Facade

HISTORIC PHOTOS



1928 Photo



1940 Photo



Current Photo

RENDERING OF PROPOSED UPDATES

New Parlor Floor Window



Proposed Design



Current Photo

HISTORIC HOMES IN BROOKLYN HEIGHTS

Precedent Studies of Mixed Open and Infilled Side Facade Openings

Hicks Street & Orange Street



Willow Street & Clark Street



Hicks Street & State Street



Hicks Street & Pierrepont Street



The neighborhood supports a mix of open and infilled side facades.

HISTORIC HOMES IN BROOKLYN HEIGHTS

Precedent Studies of Mixed Open and Infilled Side Facade Openings

Hicks Street & Middagh Street



Columbia Heights & Orange Street



Willow Street & Cranberry Street



The neighborhood supports a mix of open and infilled side facades.

HISTORIC HOMES IN BROOKLYN HEIGHTS

Precedent Studies of Mixed Open and Infilled Side Facade Openings

Orange Street & Willow Street



Orange Street & Willow Street



The neighborhood supports a mix of open and infilled side facades.

PROPOSED ELEVATIONS

East Facade (Side)

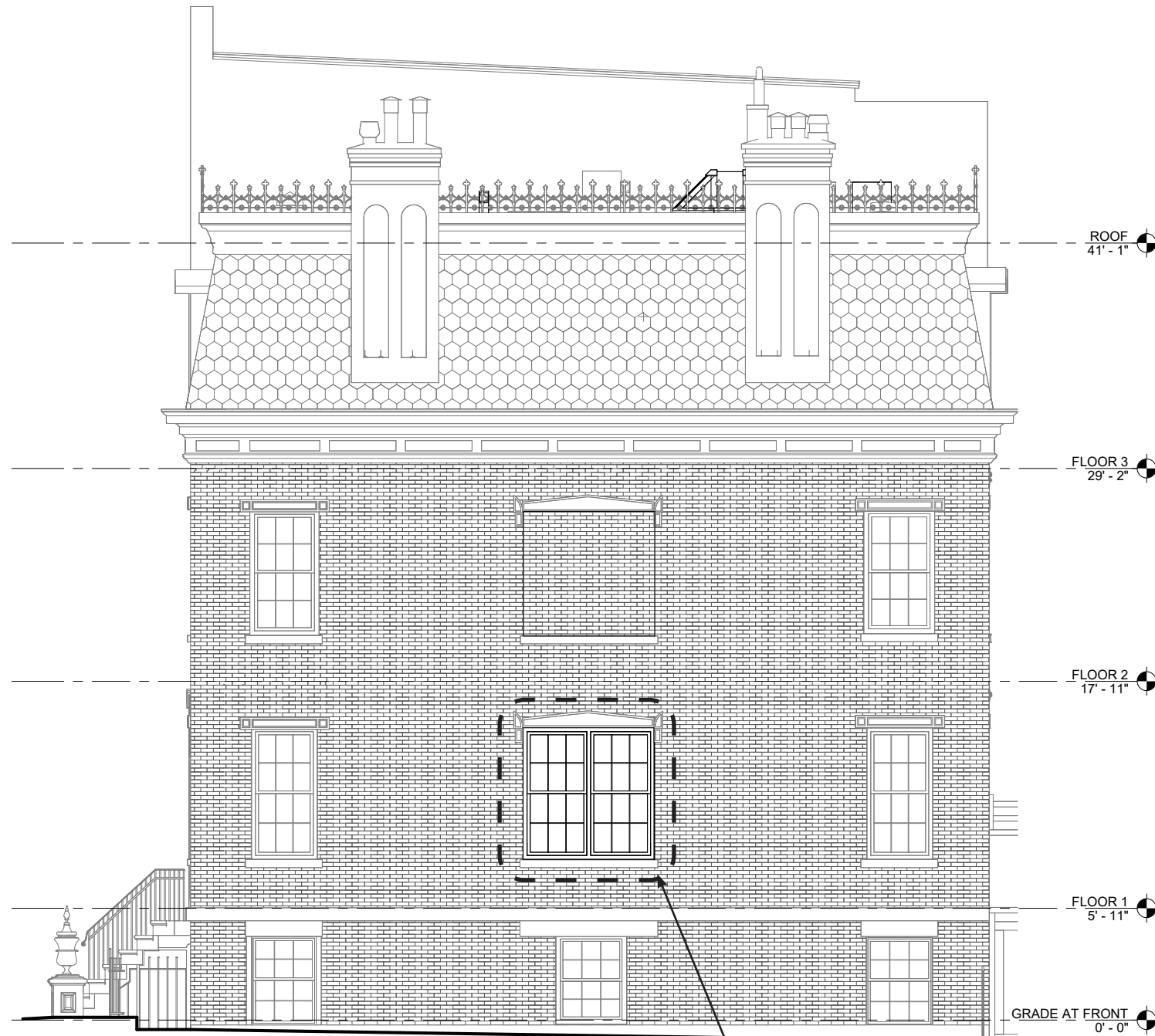

(2) new insulated double hung windows by Marvin to match existing, 6 lites over 6 lites. Enlarged elevation on Page 9.

East Elevation - Proposed

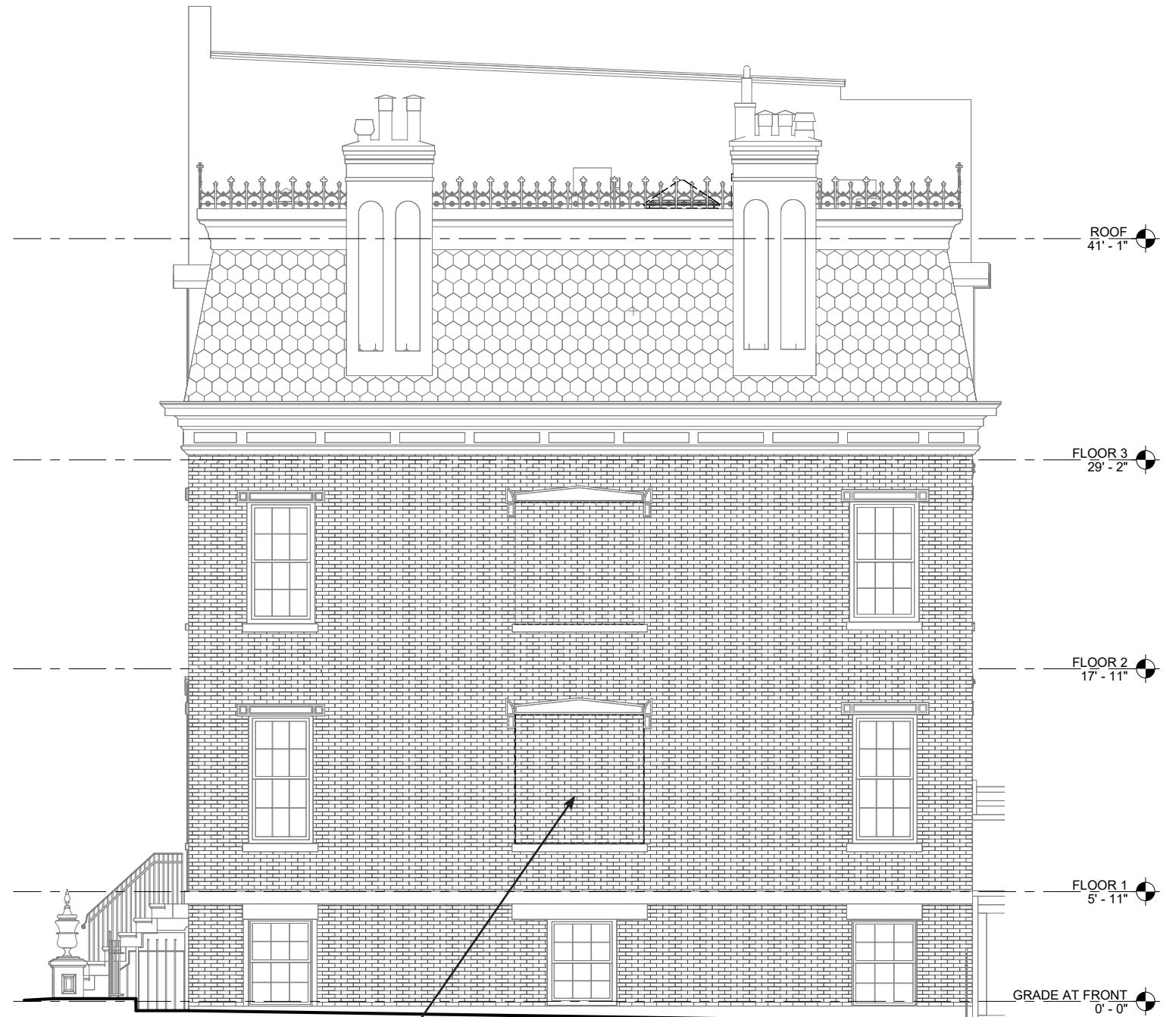

Remove existing brick infill wall at window opening. Stone lintel and sill to remain.

East Elevation - Demolition

PROPOSED WINDOWS

Enlarged Elevation

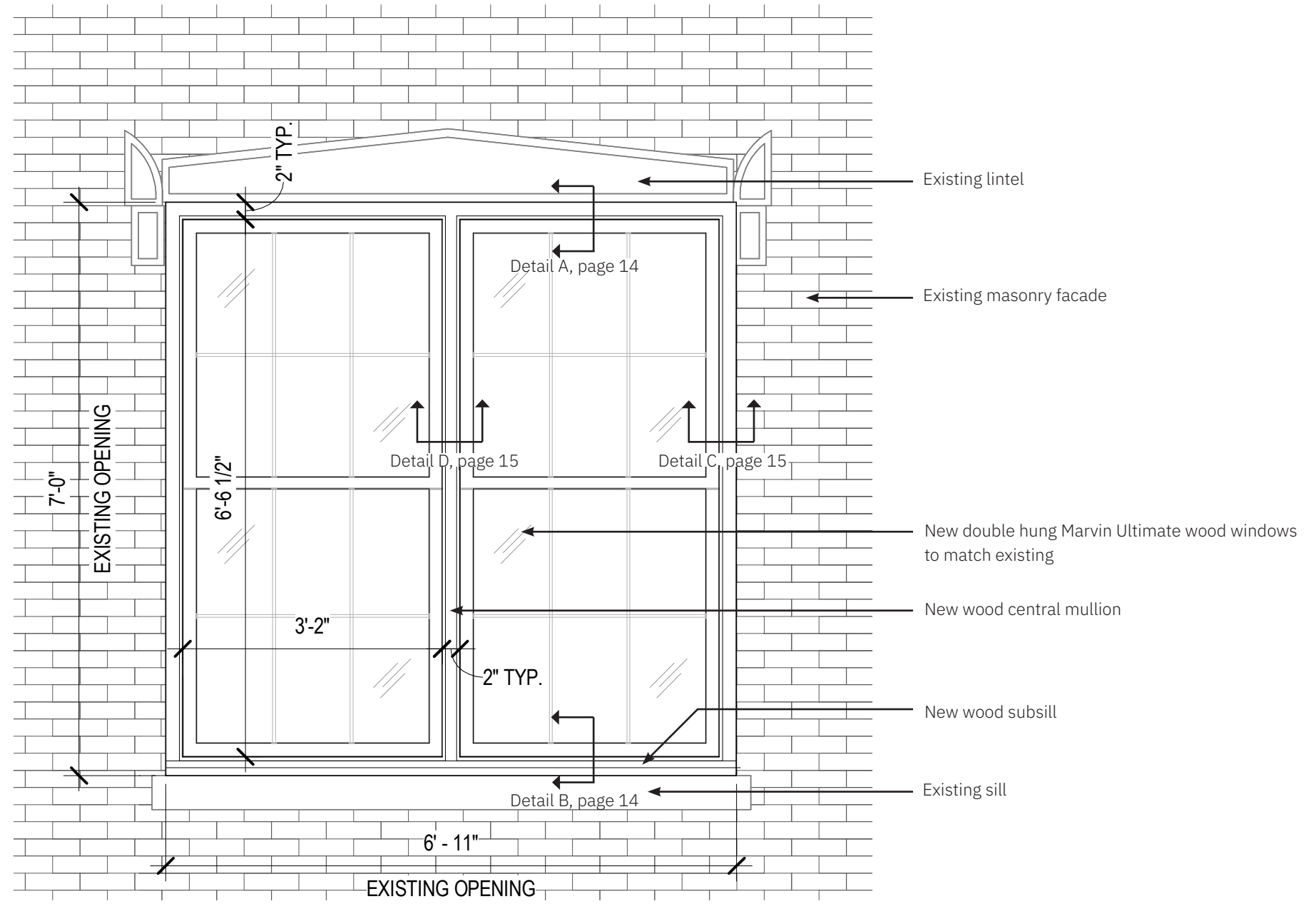

WILLOW STREET FACADE CONDITIONS

Analysis of Existing Windows and Bricked In Openings



Willow Street Facade

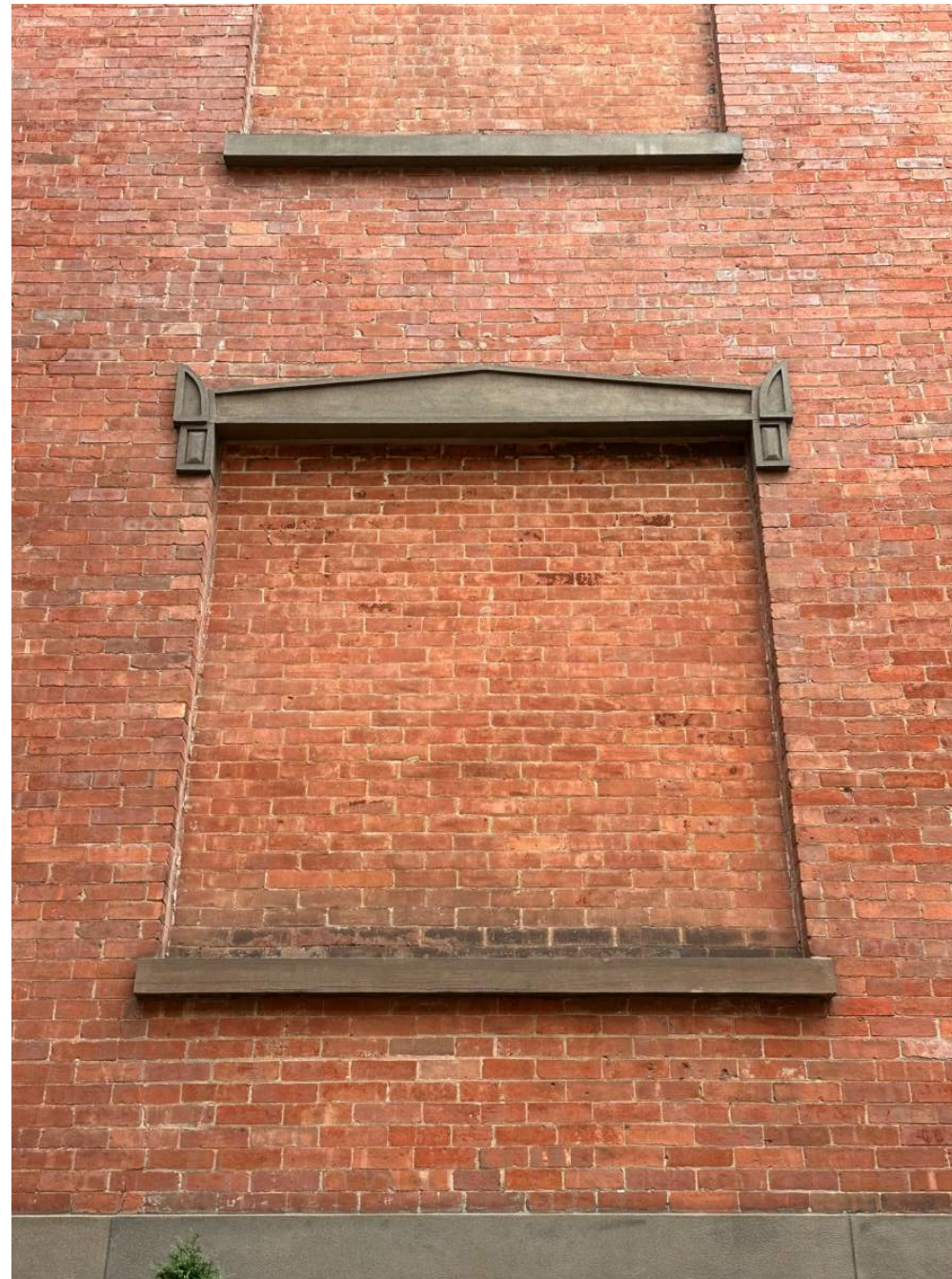

Existing Bricked in Opening



Exterior facade brick appears to have more chipping at edges than window infill brick, giving an appearance of more age. Additionally, there is more color variation in the facade brick than the infill brick, which is more homogenous in color.

Mortar joints at window infill brick are tooled flush as opposed to raked joints at facade brick, indicating that it was constructed at a time after the house was built.

Existing Stone Lintel Detail



Stone lintel and sill indicate intent for window at opening.

Existing Stone Sill Detail

PROPOSED PLANS

Exterior Scope - 1st Floor / Parlor Floor

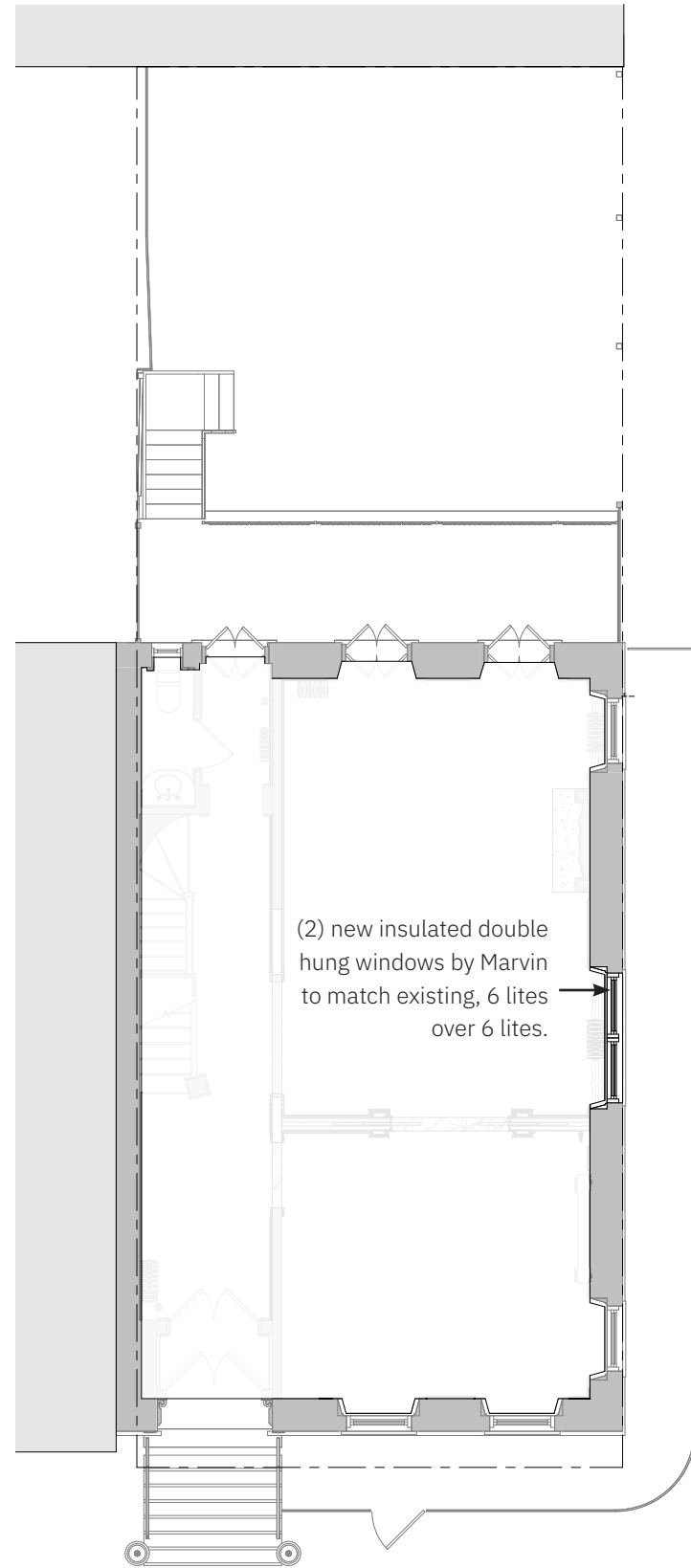

Proposed Plan

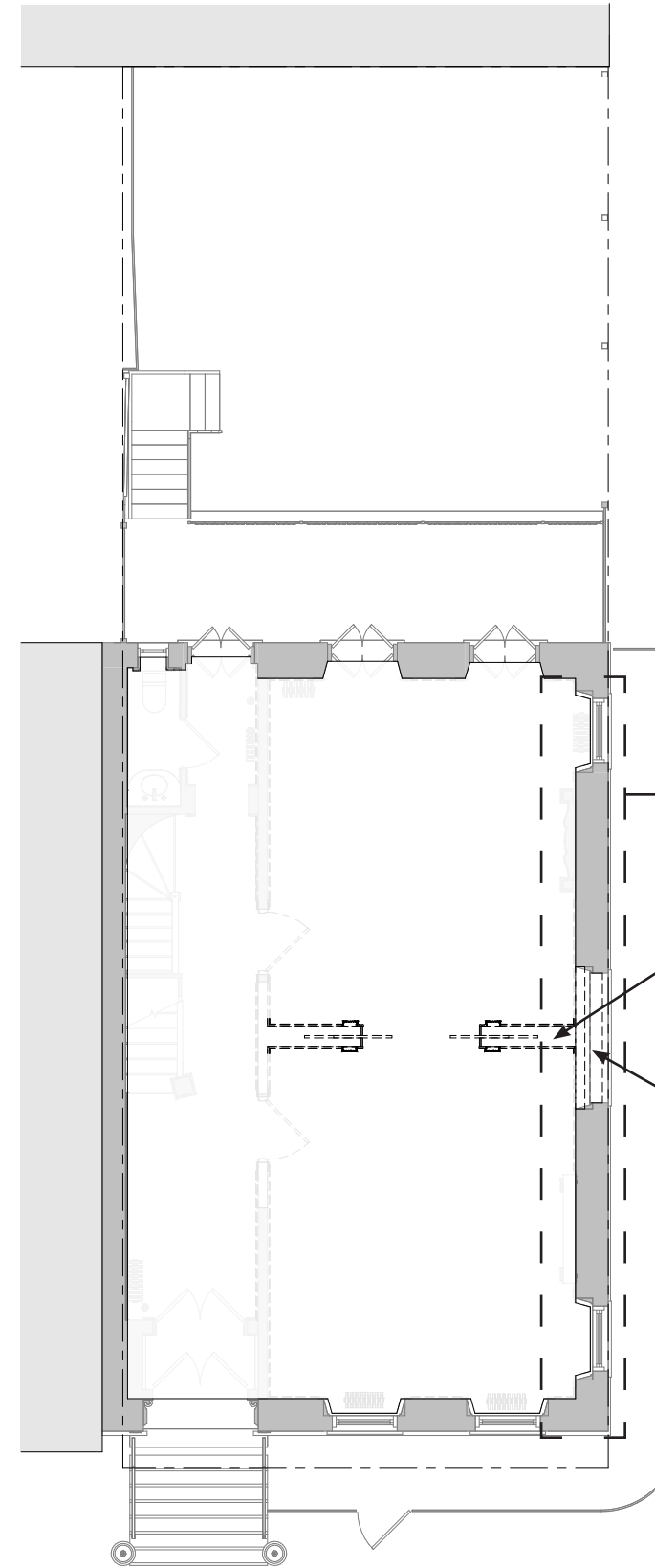

Demolition Plan

EXISTING WINDOWS AT WILLOW ST

Photos



Existing Typical Window:
Marvin Ultimate Wood Double Hung Magnum



Existing Typical Window Details

PROPOSED WINDOWS

Custom Details - Marvin Ultimate Wood Double Hung Magnum

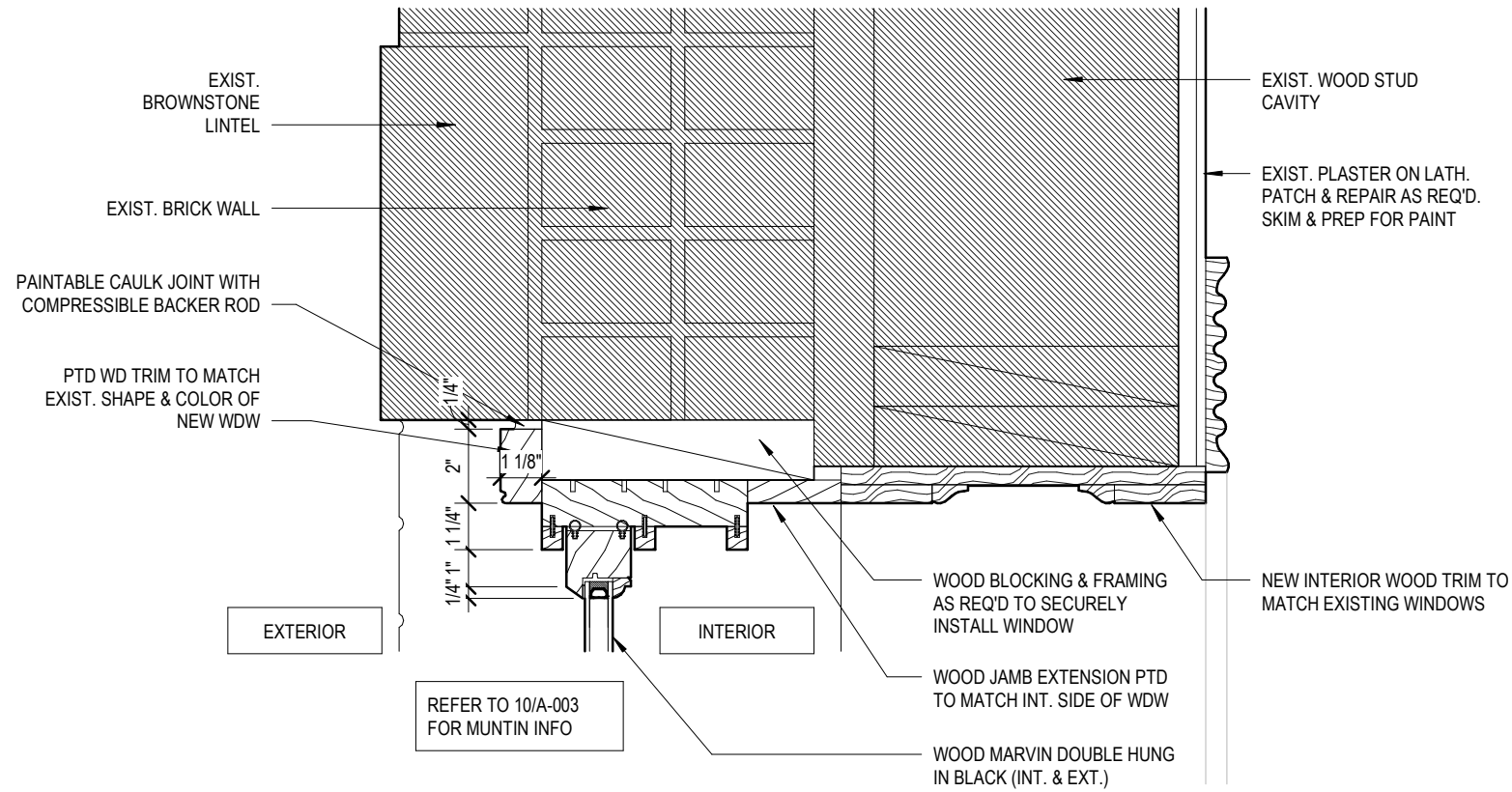

Detail "A" at Window Head

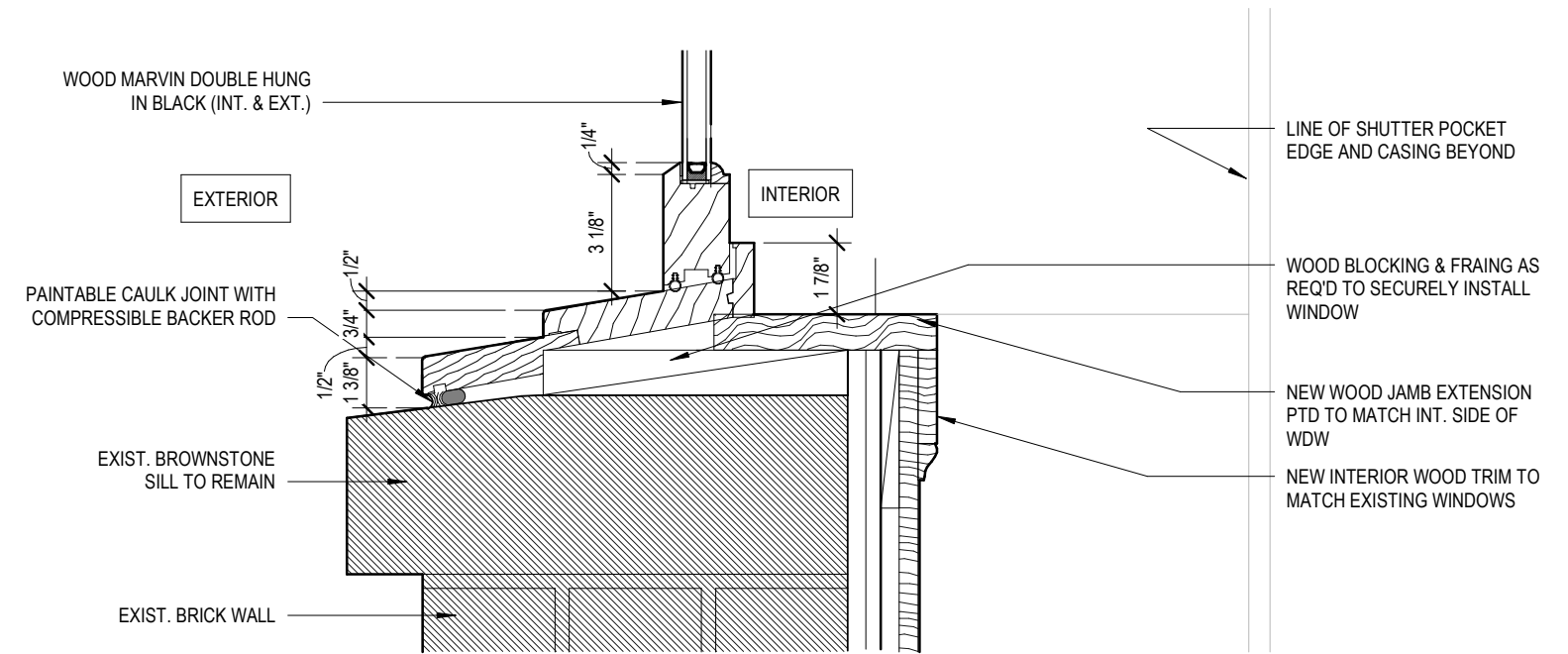

Detail "B" at Window Sill

PROPOSED WINDOWS

Custom Details - Marvin Ultimate Wood Double Hung Magnum

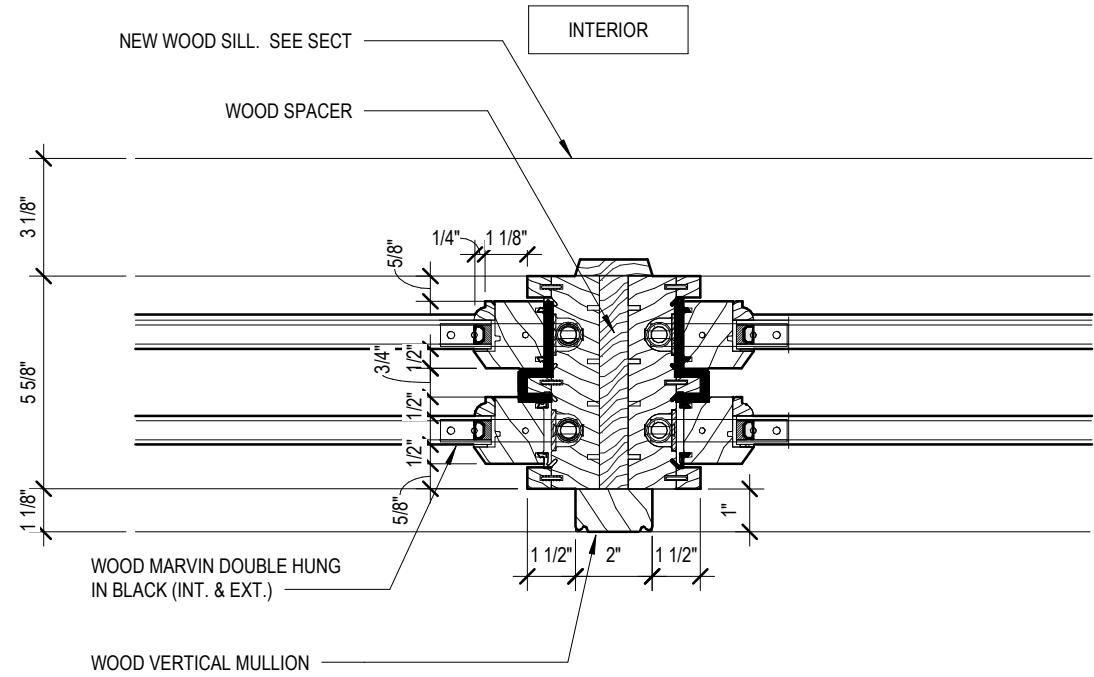

Detail "D" at Vertical Window Mullion

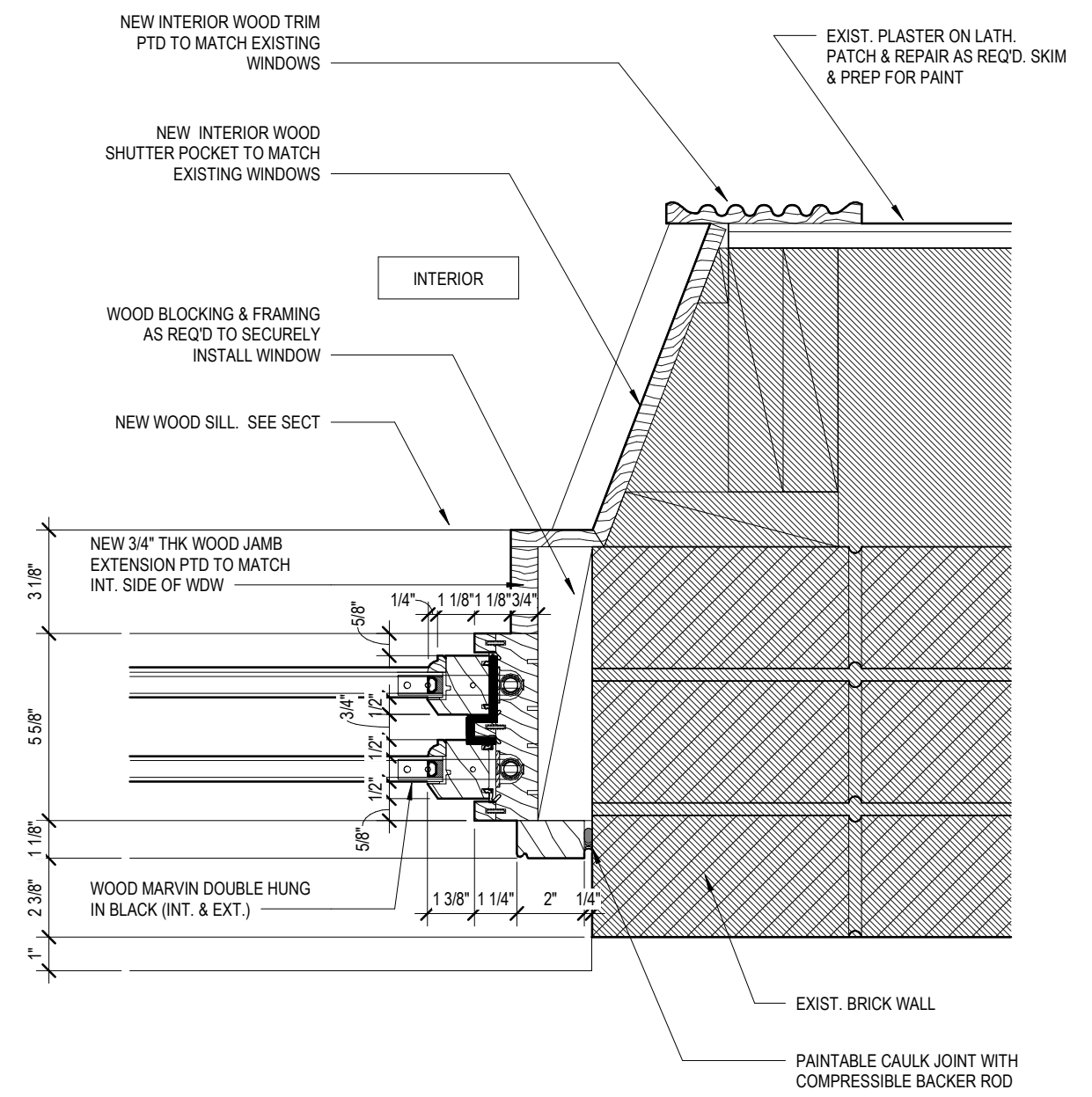

Detail "C" at Window Jamb

PROPOSED DESIGN - EXTERIOR

Axonometric



1st Floor: (2) New Marvin Ultimate Wood Double Hung Magnum Windows, to match existing windows

June 2, 2026
Public Hearing

The current proposal is:

Preservation Department – Item 4, LPC-26-06032

19 Cranberry Street – Brooklyn Heights Historic District Borough of Brooklyn

To testify virtually, please join Zoom

Webinar ID: 165 104 6126

Passcode: 717488

By Phone: 646-828-7666 (NY)

833-435-1820 (Toll-free)

833-568-8864 (Toll-free)

Note: If you want to testify virtually on an item, join the Zoom webinar at the agenda's "Be Here by" time (about an hour in advance). When the Chair indicates it's time to testify, "raise your hand" via the Zoom app if you want to speak (*9 on the phone). Those who signed up in advance will be called first.