

May 19, 2026  
Public Hearing

The current proposal is:

Preservation Department – Item 4, LPC-26-09561

## **39 Bethune Street – Greenwich Village Historic District Borough of Manhattan**

**To testify virtually, please join Zoom**

**Webinar ID:** 165 215 8714

**Passcode:** 958652

By Phone: 646-828-7666 (NY)

833-435-1820 (Toll-free)

833-568-8864 (Toll-free)

**Note:** If you want to testify virtually on an item, join the Zoom webinar at the agenda's "Be Here by" time (about an hour in advance). When the Chair indicates it's time to testify, "raise your hand" via the Zoom app if you want to speak (\*9 on the phone). Those who signed up in advance will be called first.

# 39 Bethune Street New York, NY 10014



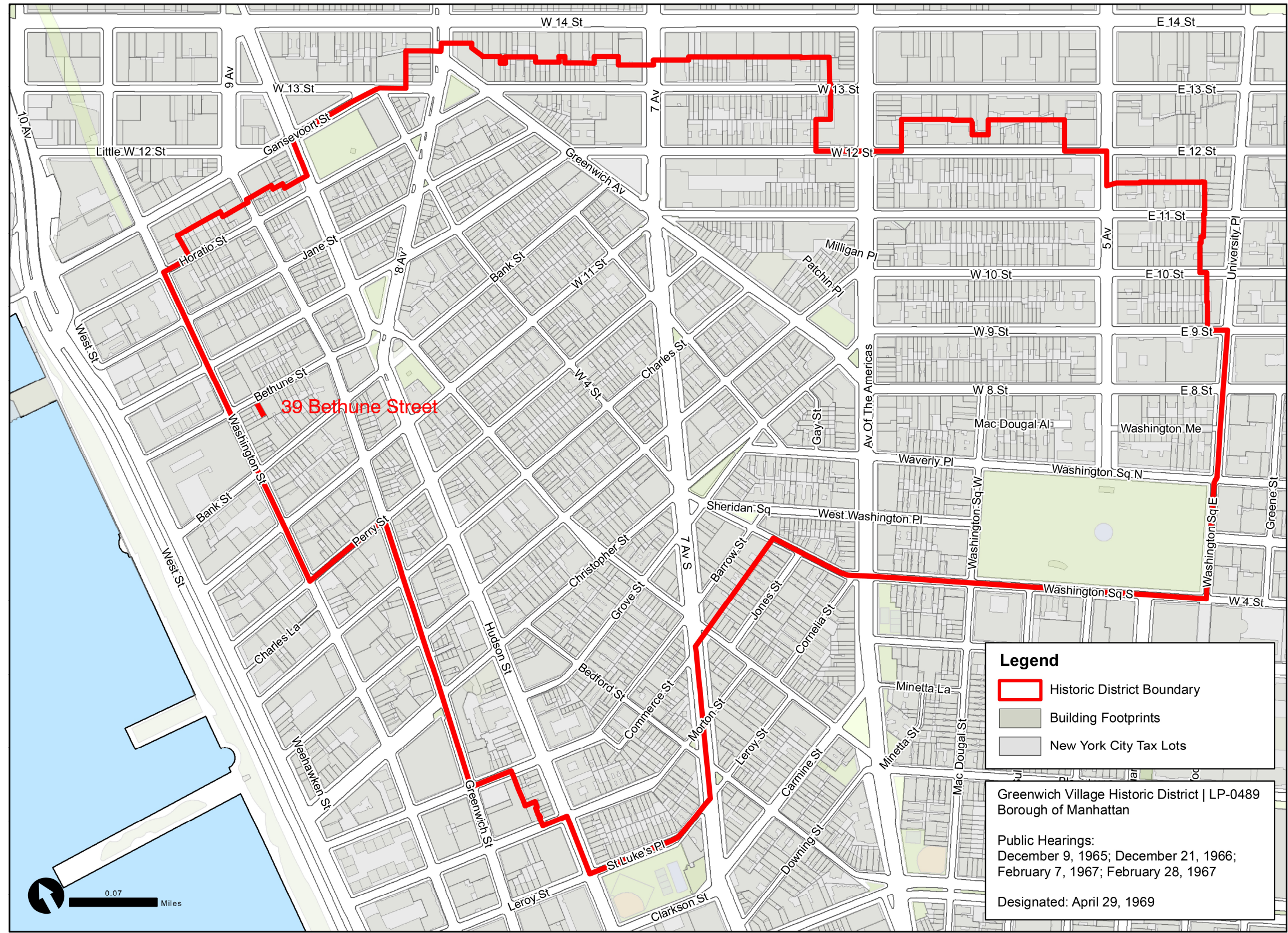

Graphic Source: Map PLUTO, Edition 18v1, Author: New York City Landmarks Preservation Commission, LCR Date: 2.20.2019



1940 Tax Photo

Charles H. Henkels, AIA  
Architects

39 Bethune Street  
Greenwich Village Historic District



39 Bethune as Pickwick Papers (undated)

Historic Photos



Bethune Street South Side, From and Including Washington Street, NYPL 709/C1

Charles H. Henkels, AIA  
Architects

39 Bethune Street  
Greenwich Village Historic District



41 Bethune Street Tax Photo 1940

Historic Photos



Photo 1: 39 Bethune Street Street Facade



Photo 2: Bethune Street Street View Looking East



Photo 3: Bethune Street Street View Looking West



Photo 4: From 35 Bethune Street Looking Southwest towards Washington Street



Photo 5: From 35 Bethune Street Looking West Towards Washington Street



Photo 6: 39 Bethune Street Existing Greenhouse at Terrace Looking North



Photo 7: 39 Bethune Street Existing Greenhouse



Photo 8: 39 Bethune Street Existing Terrace Looking Southwest



Photo 9: 39 Bethune Street Existing Terrace Looking East



Photo 9: West side of Washington Street looking east over Lichtenstein Foundation one story building. No visibility from Washington Street. West red brick wall of 35 Bethune Street is visible.

Charles H. Henkels, AIA  
Architects

39 Bethune Street  
Greenwich Village Historic District

Existing Conditions Photos

7.1

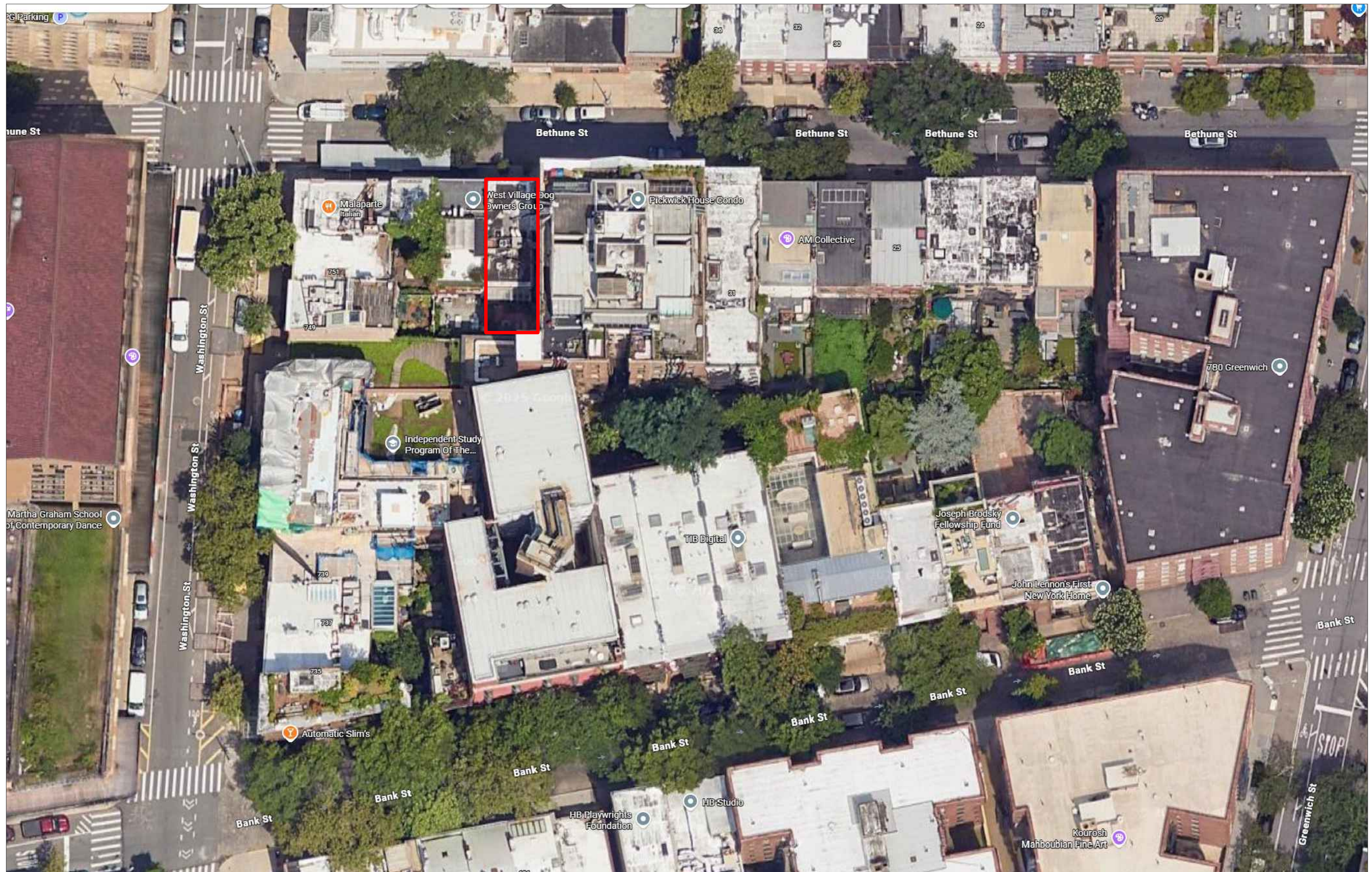

Source: Google Maps

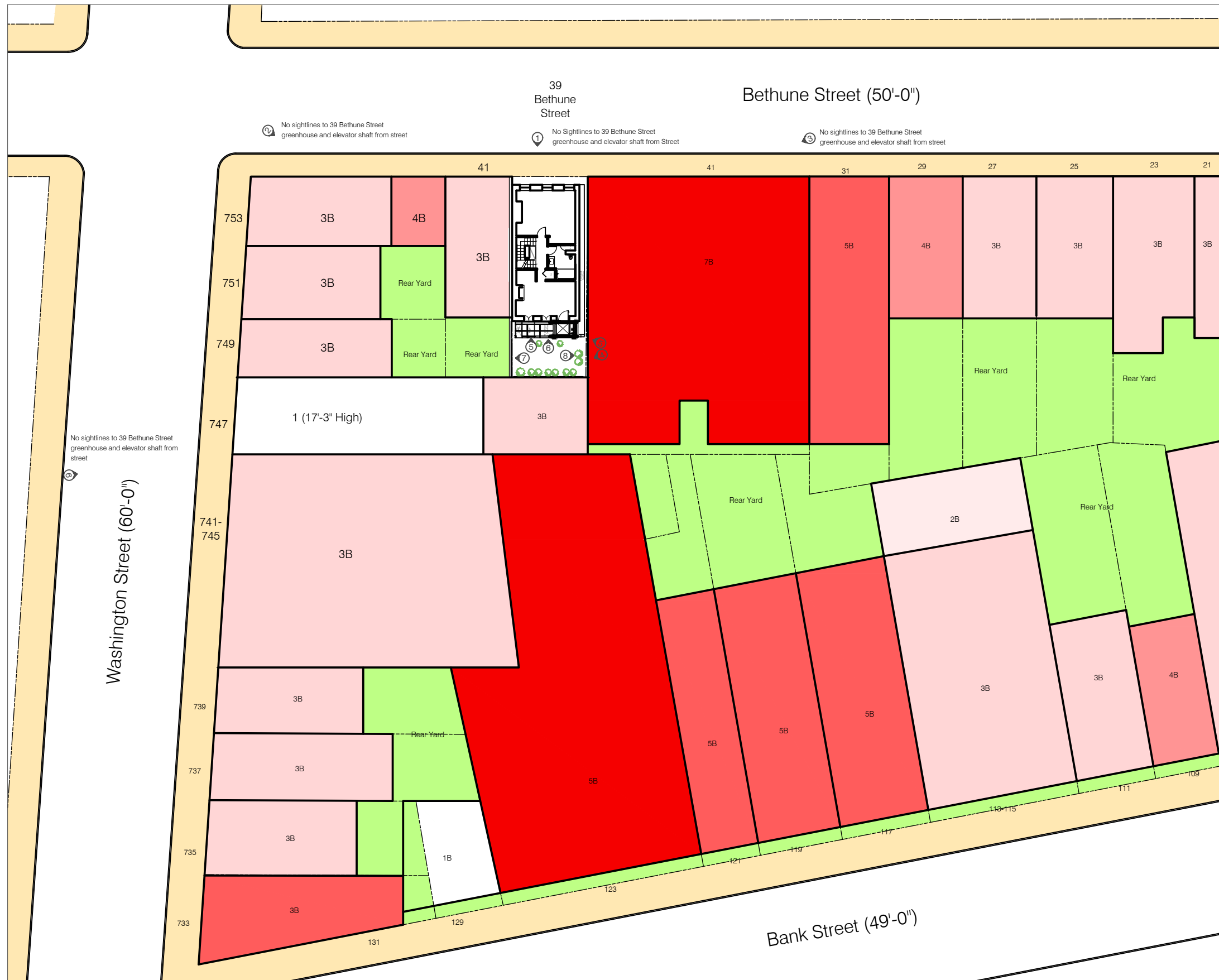

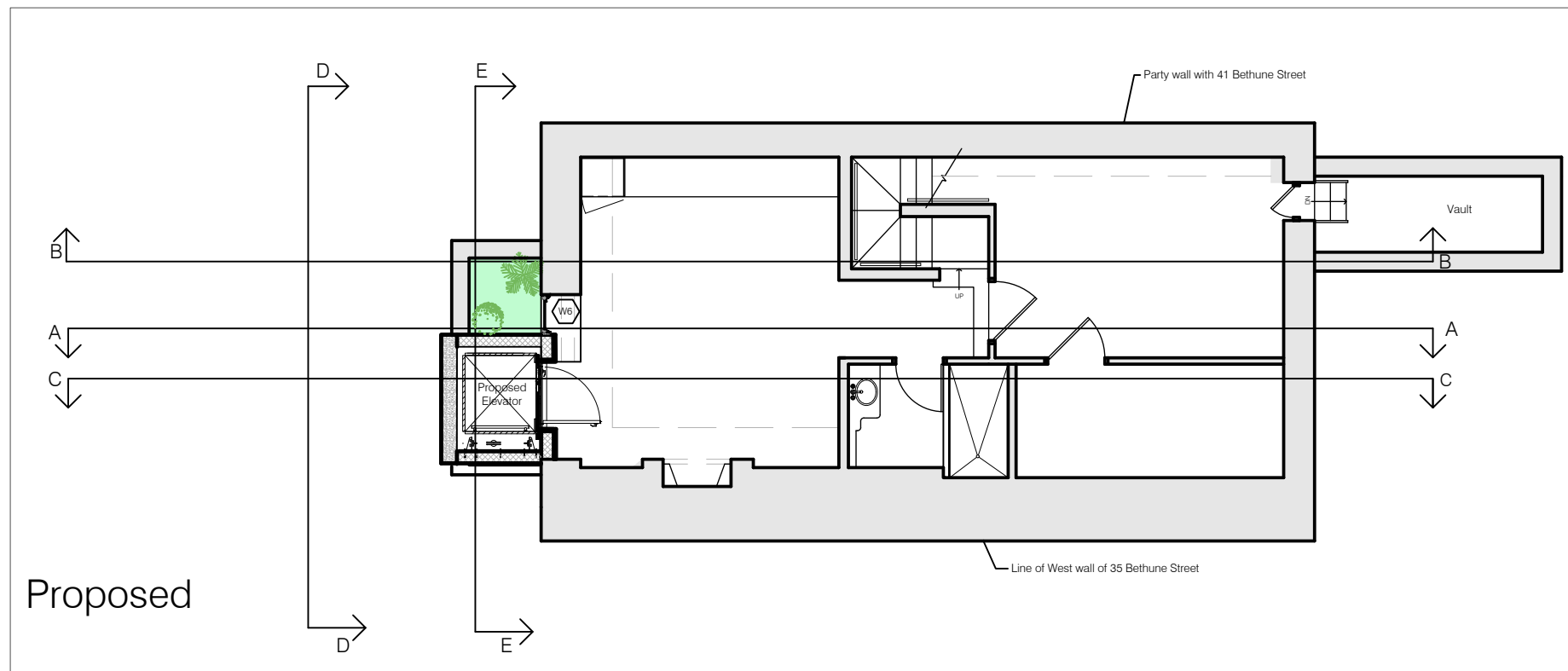
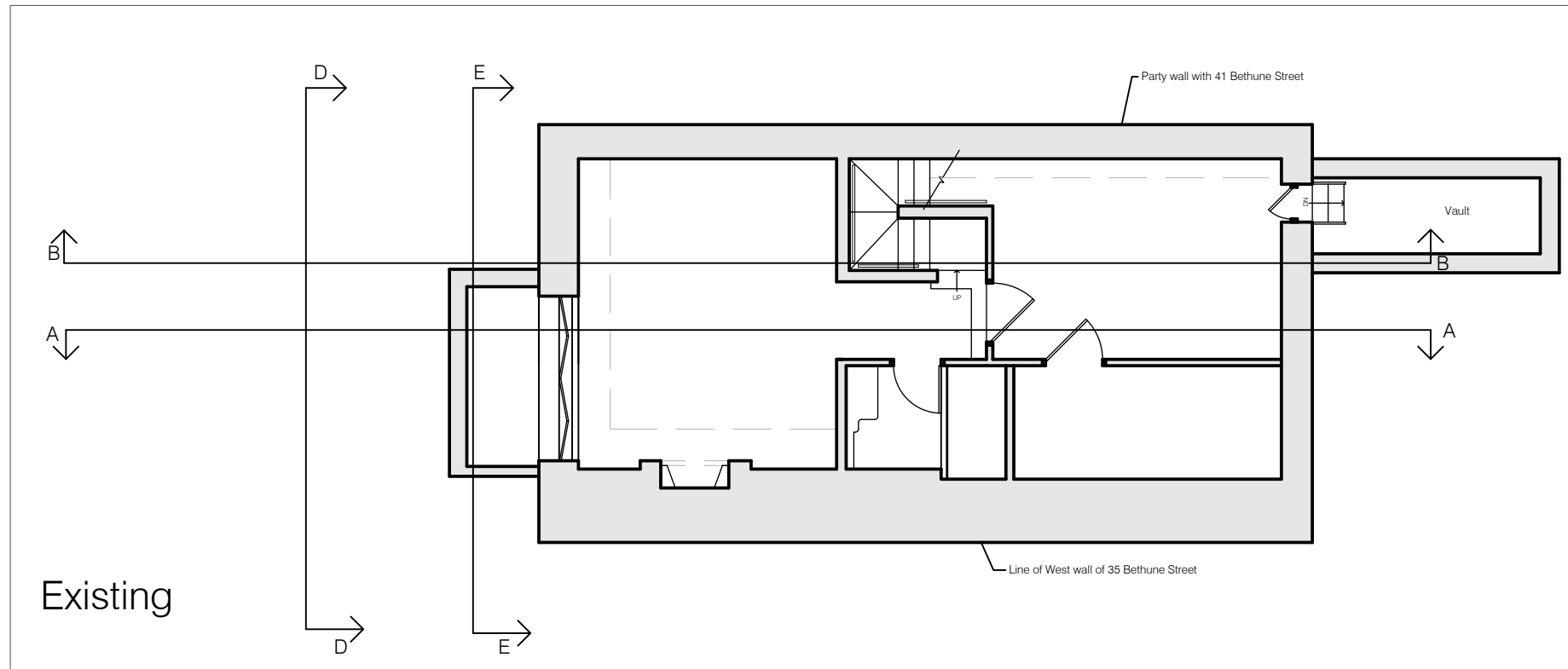

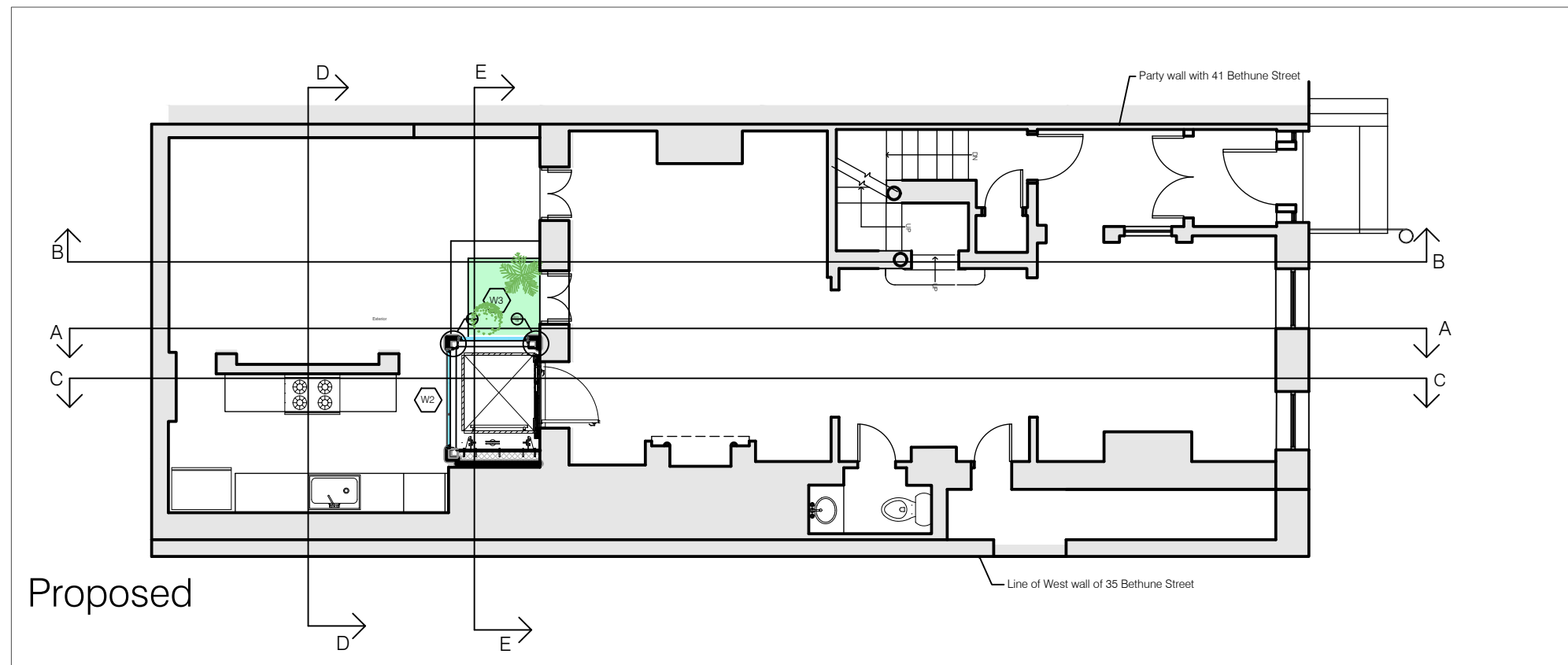
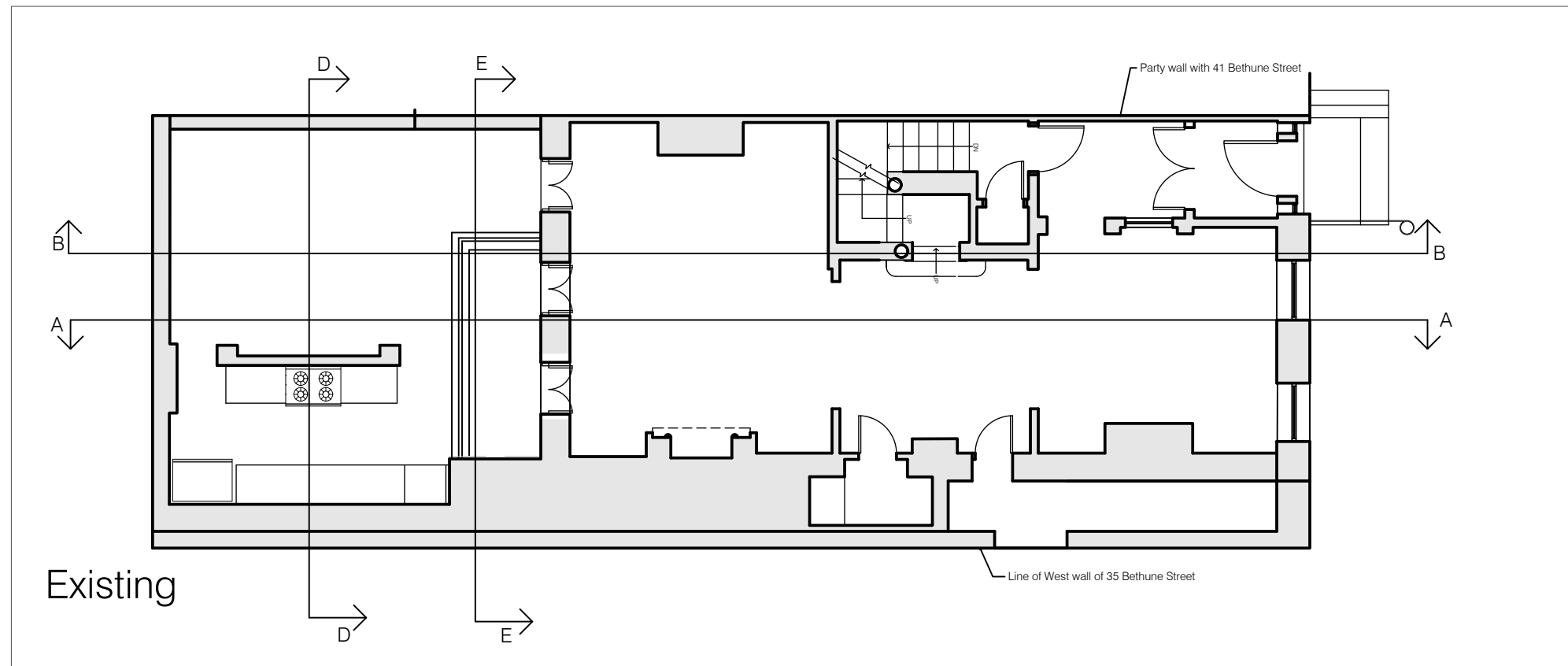

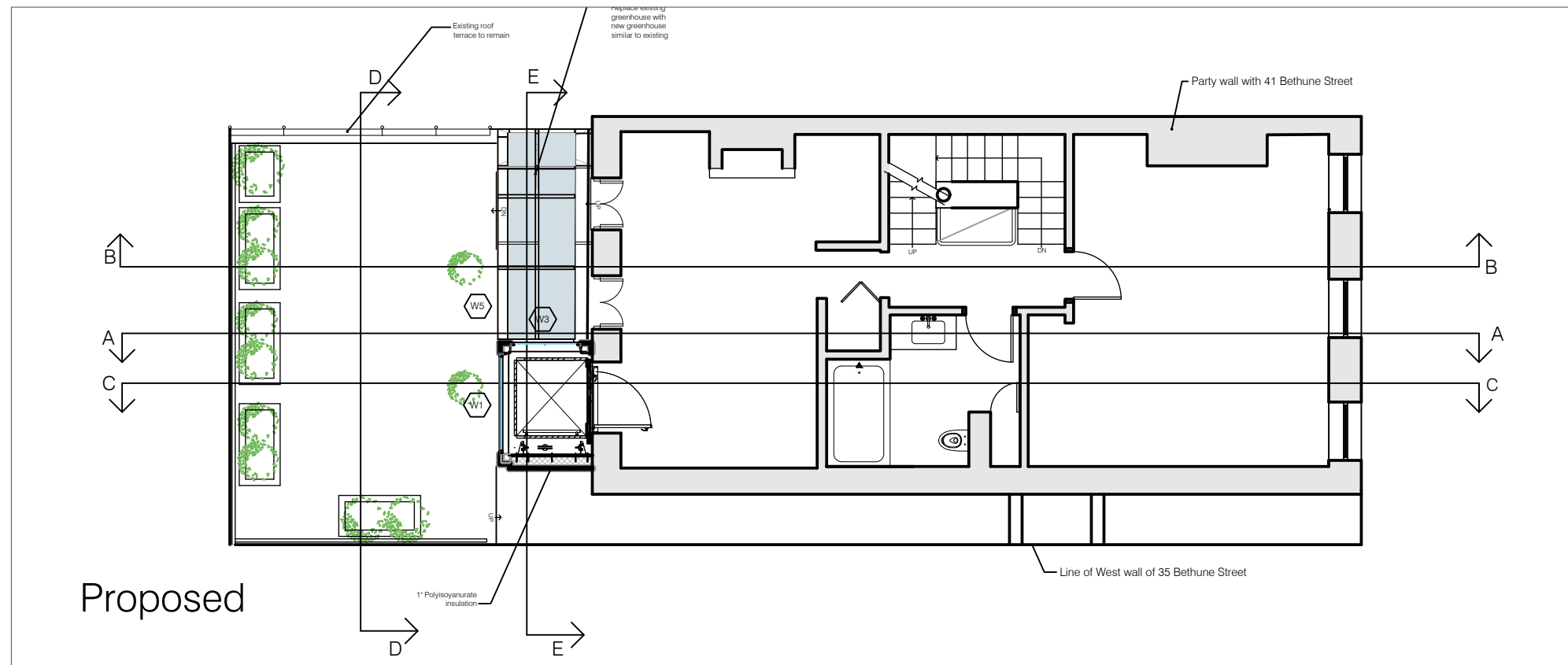
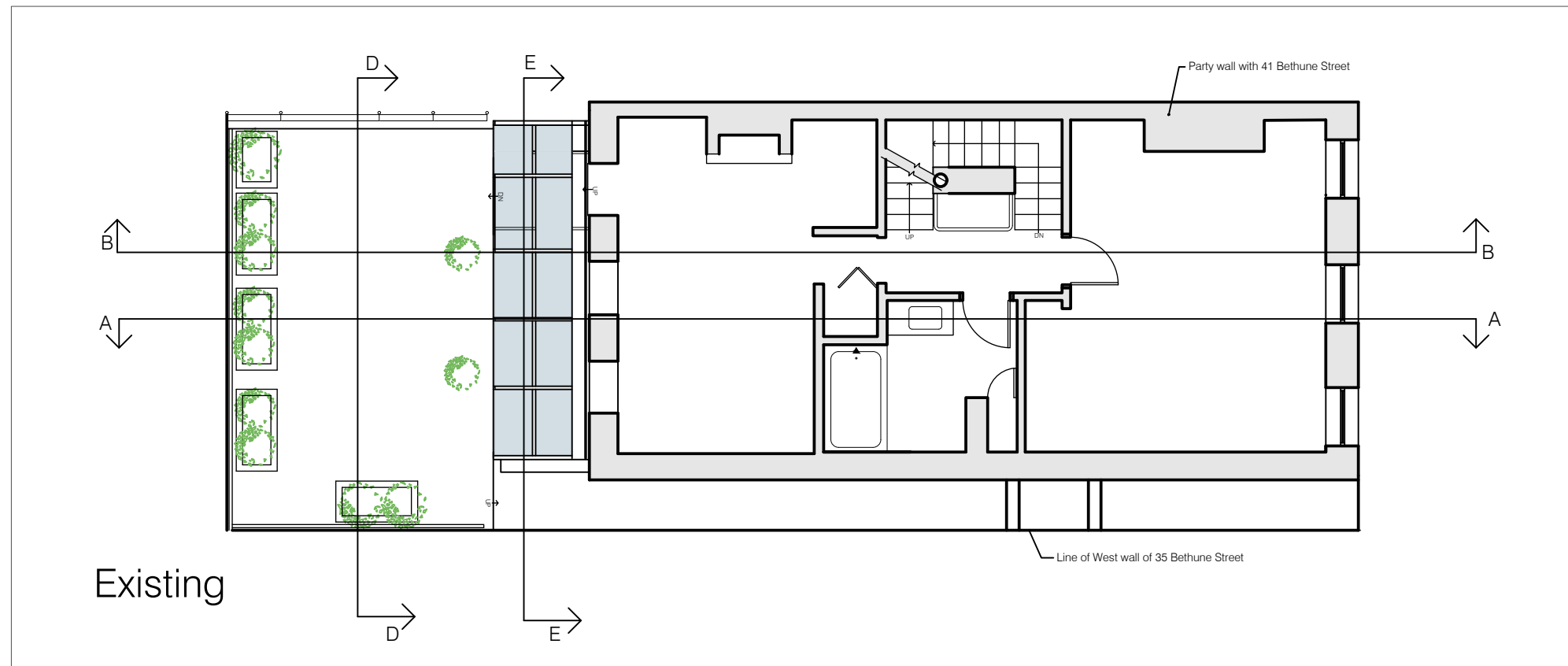

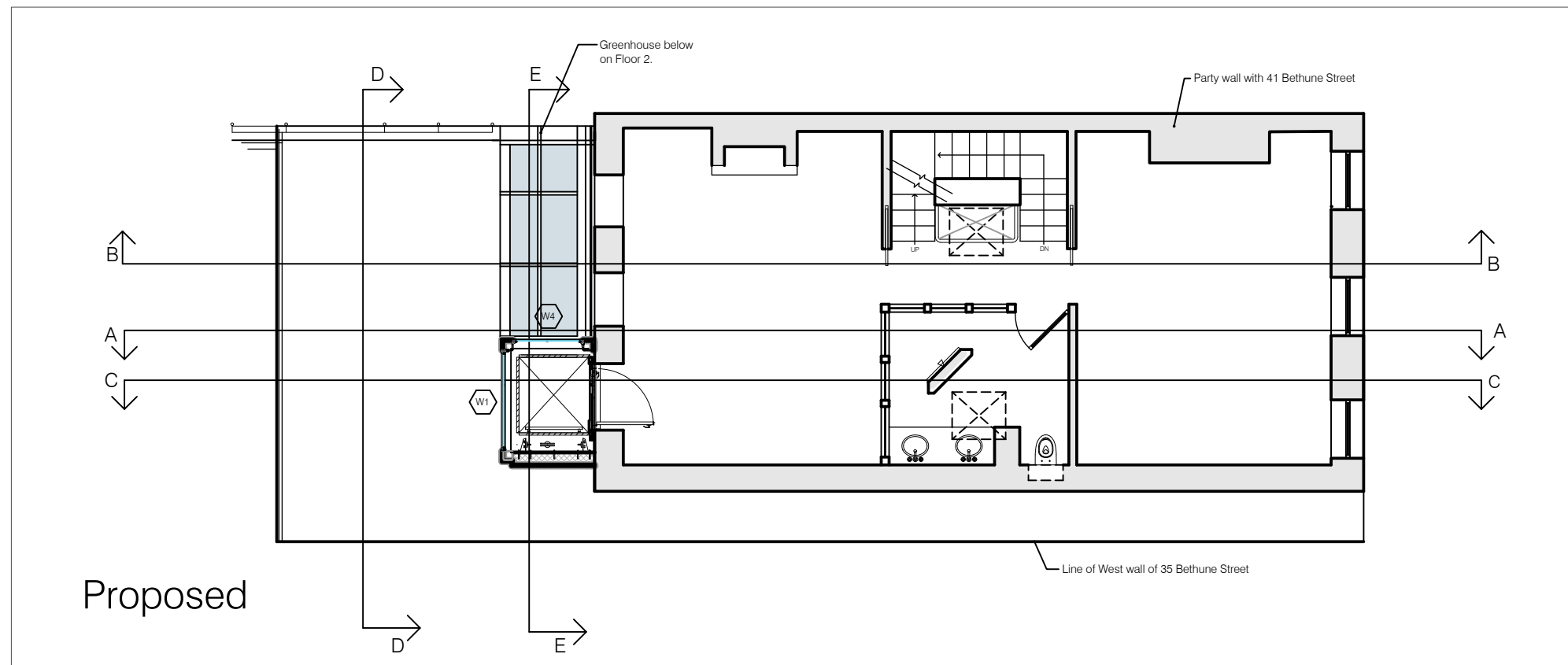
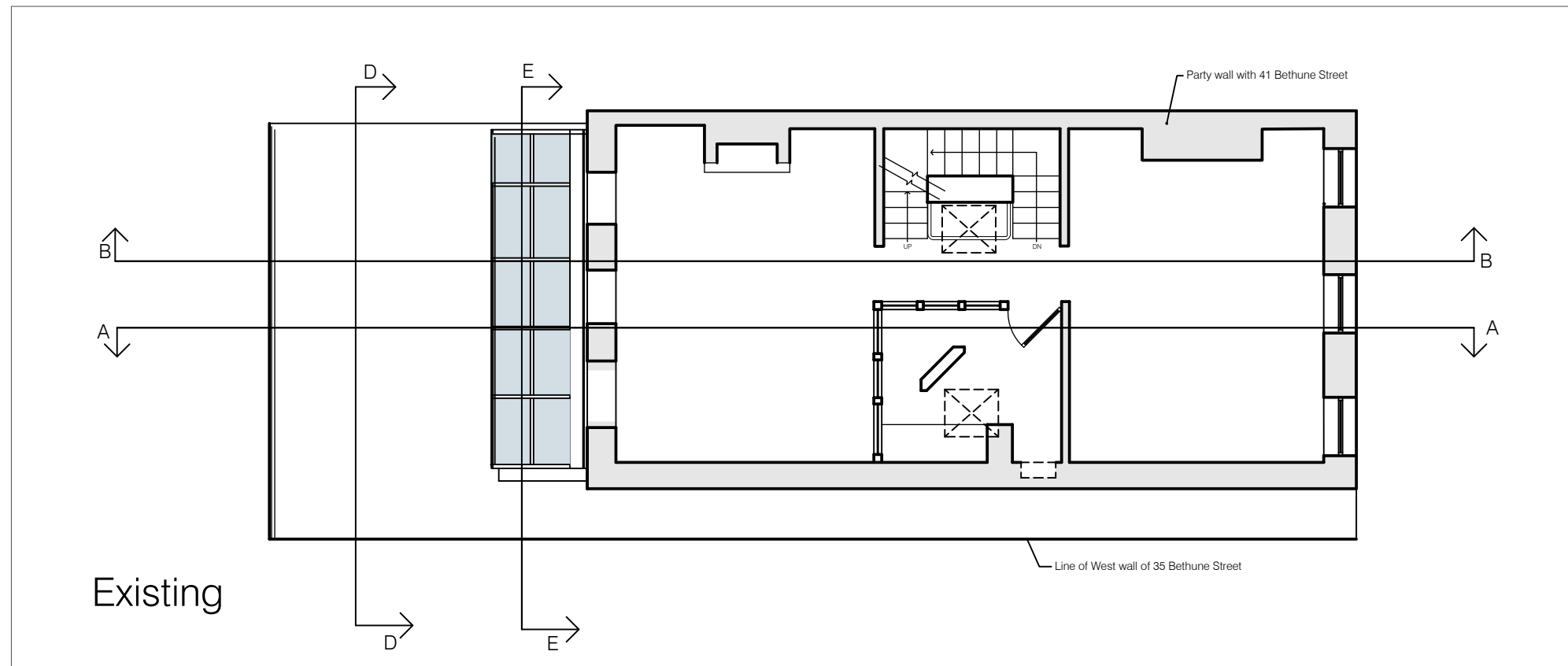

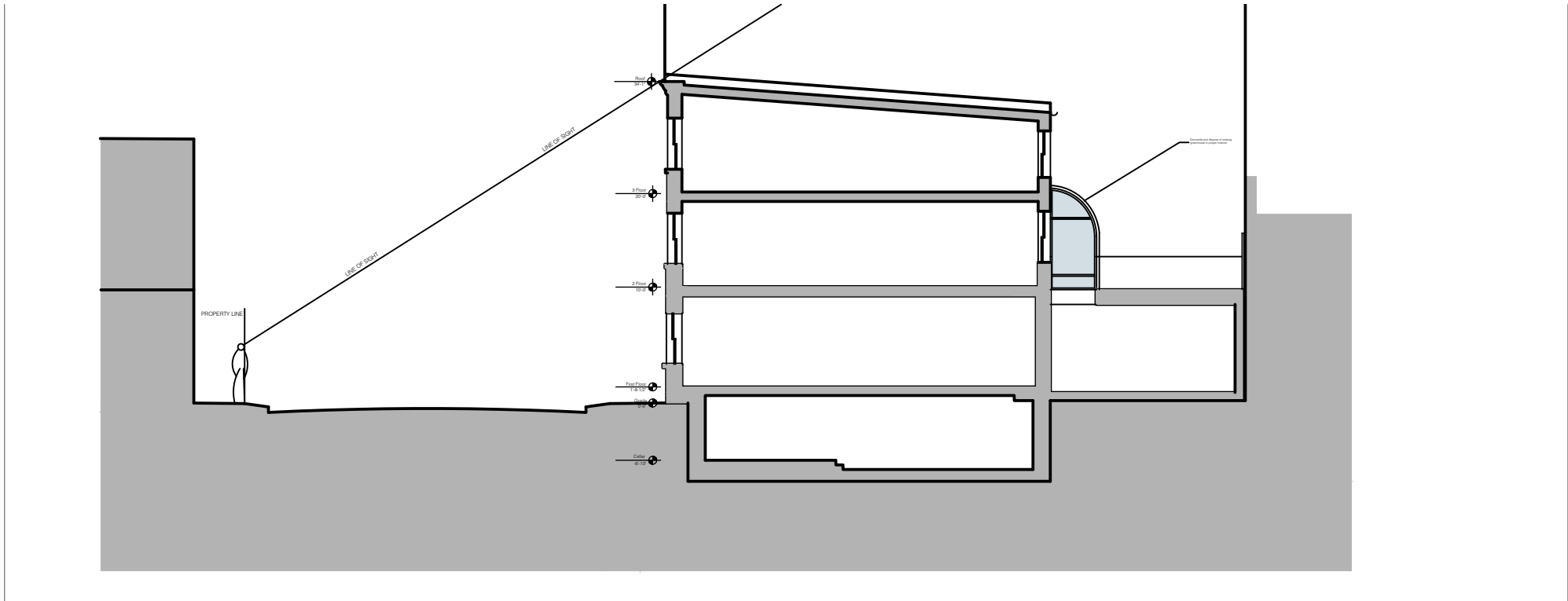

Existing

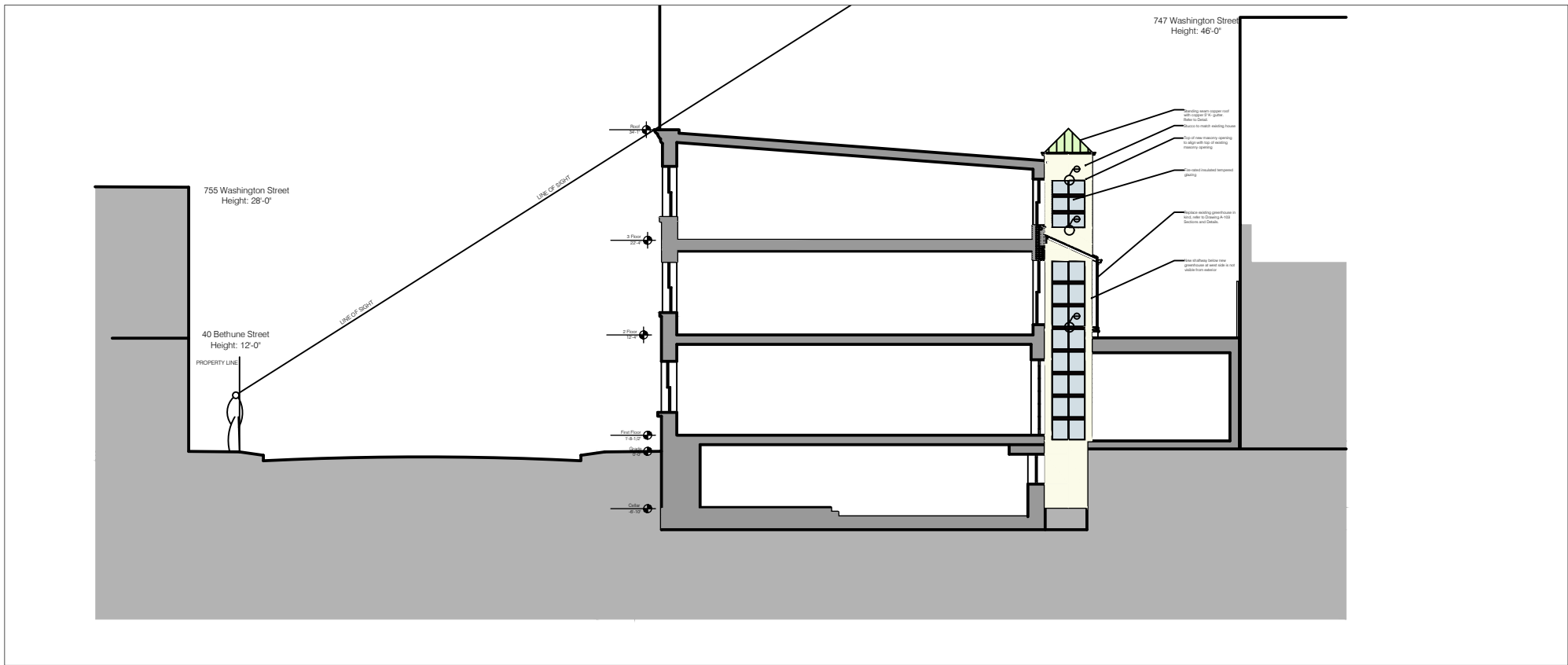

Proposed

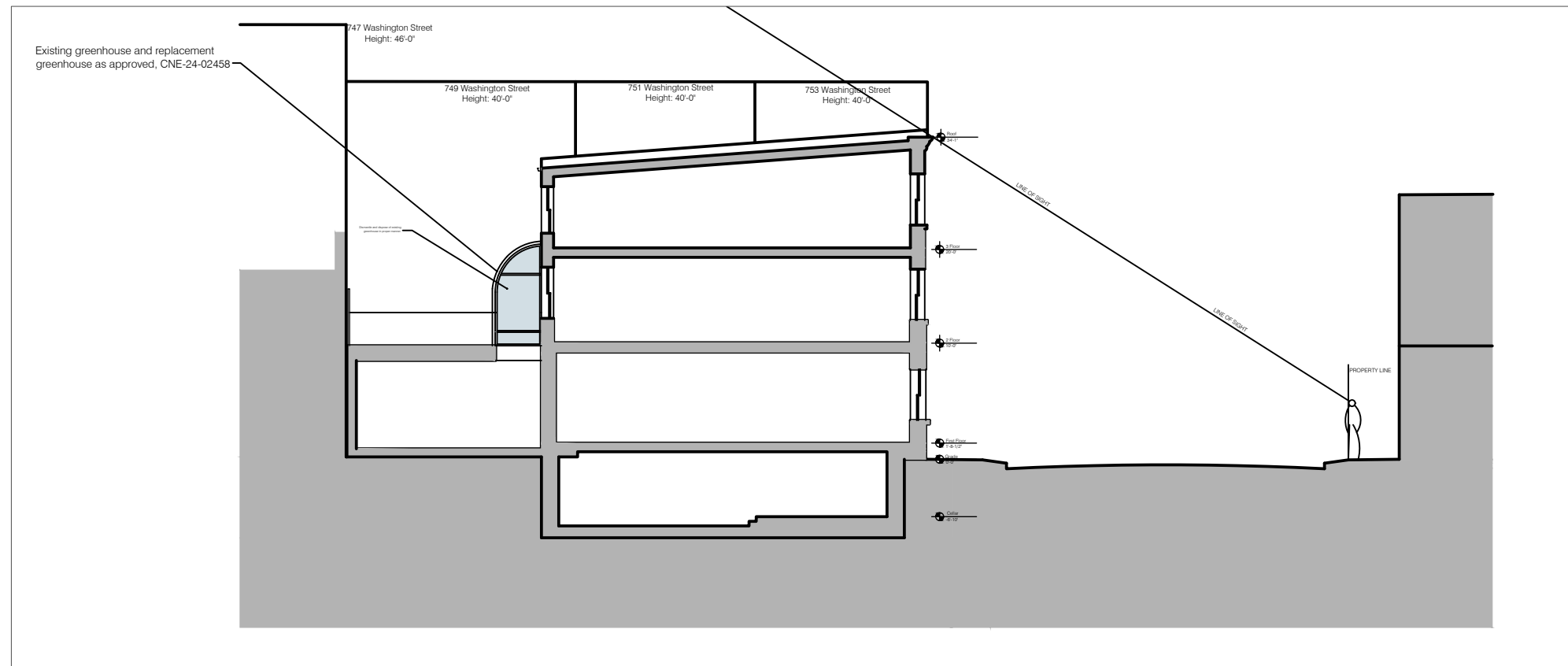

Existing

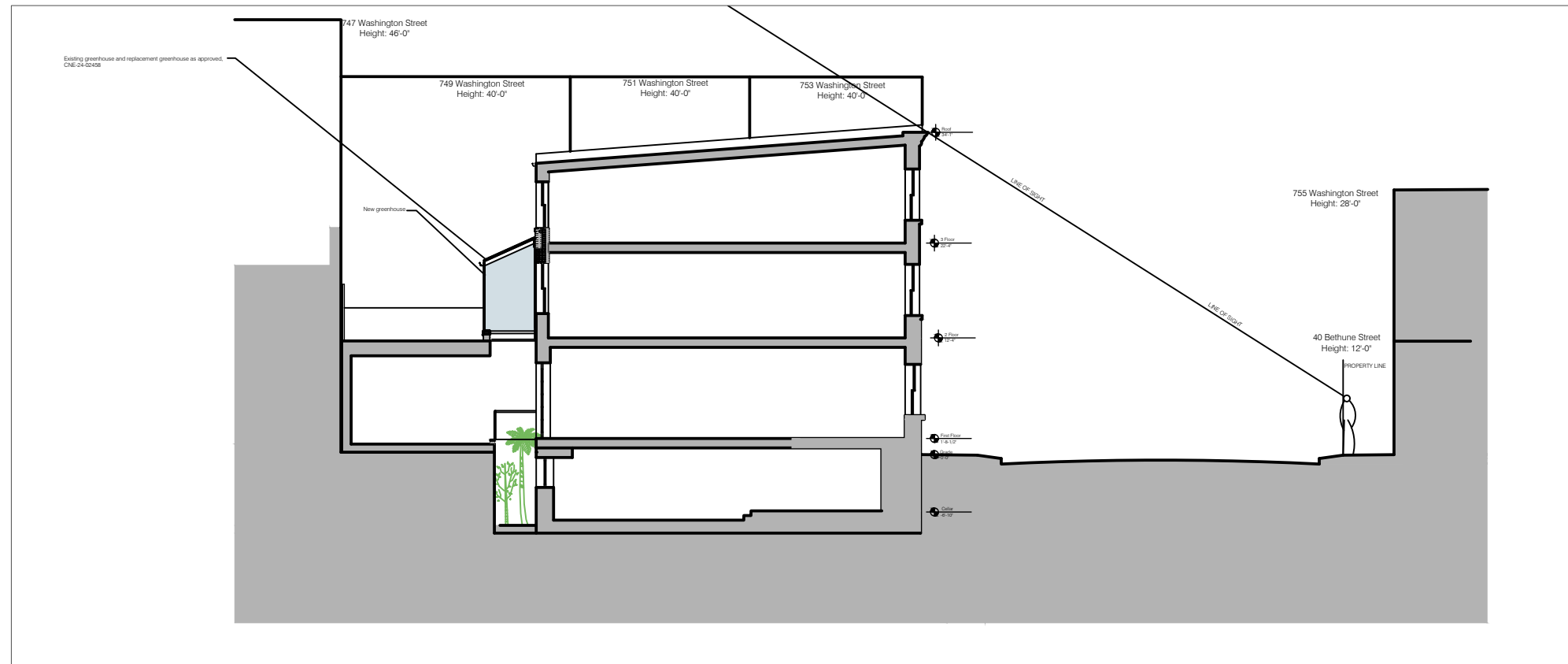

Proposed

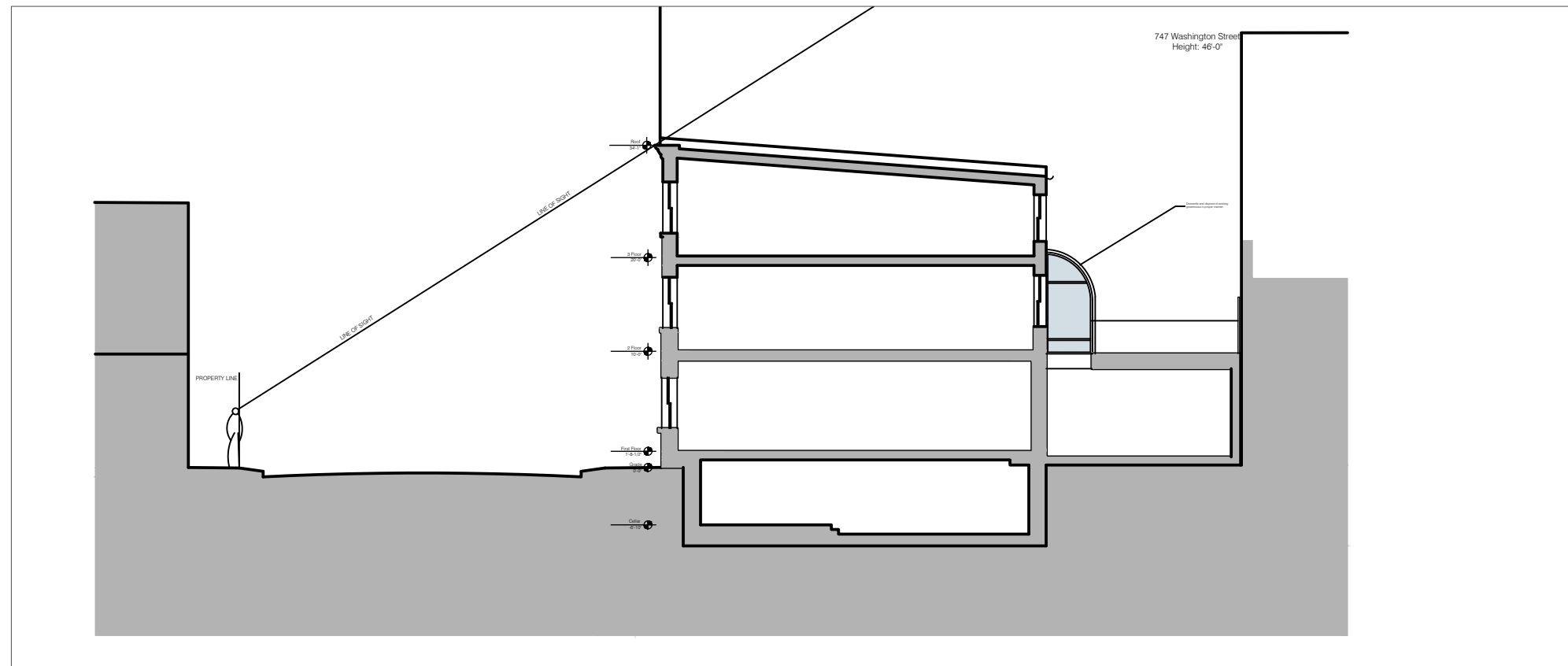

Existing

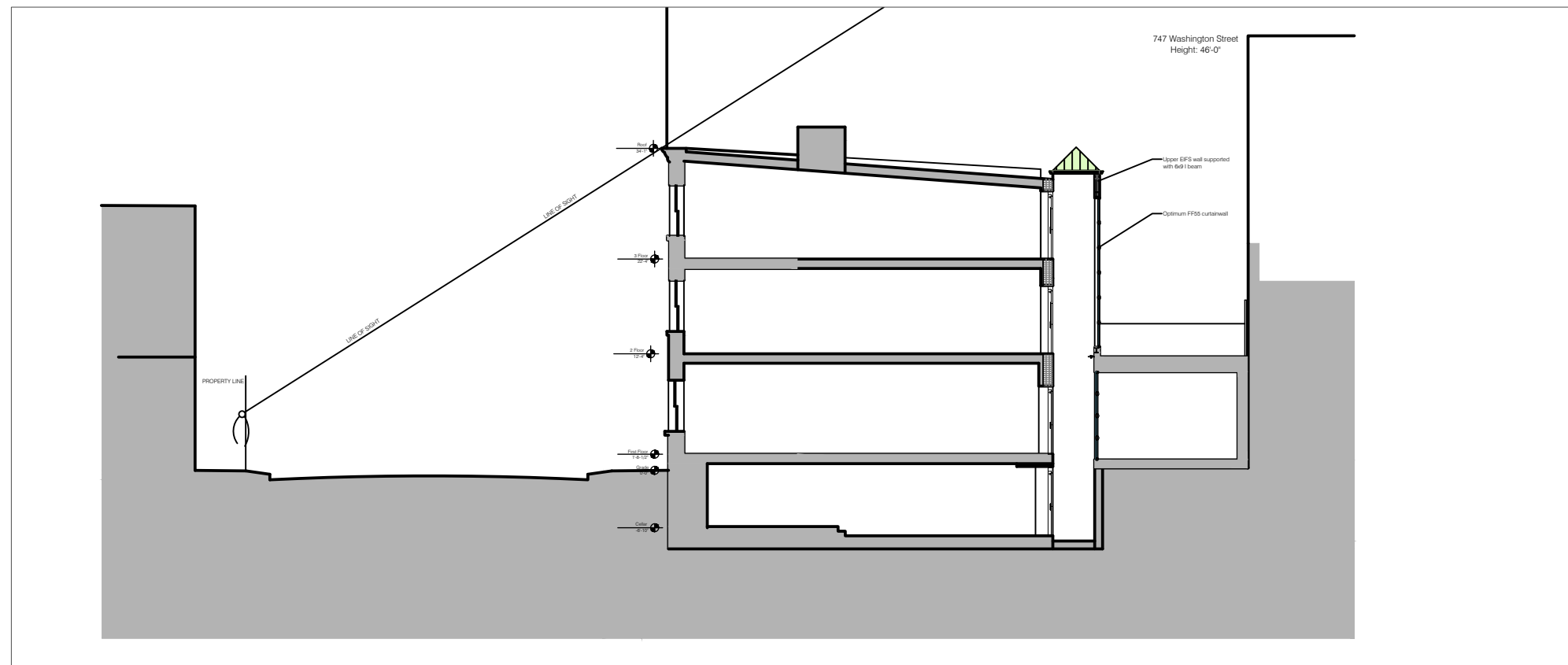

Proposed

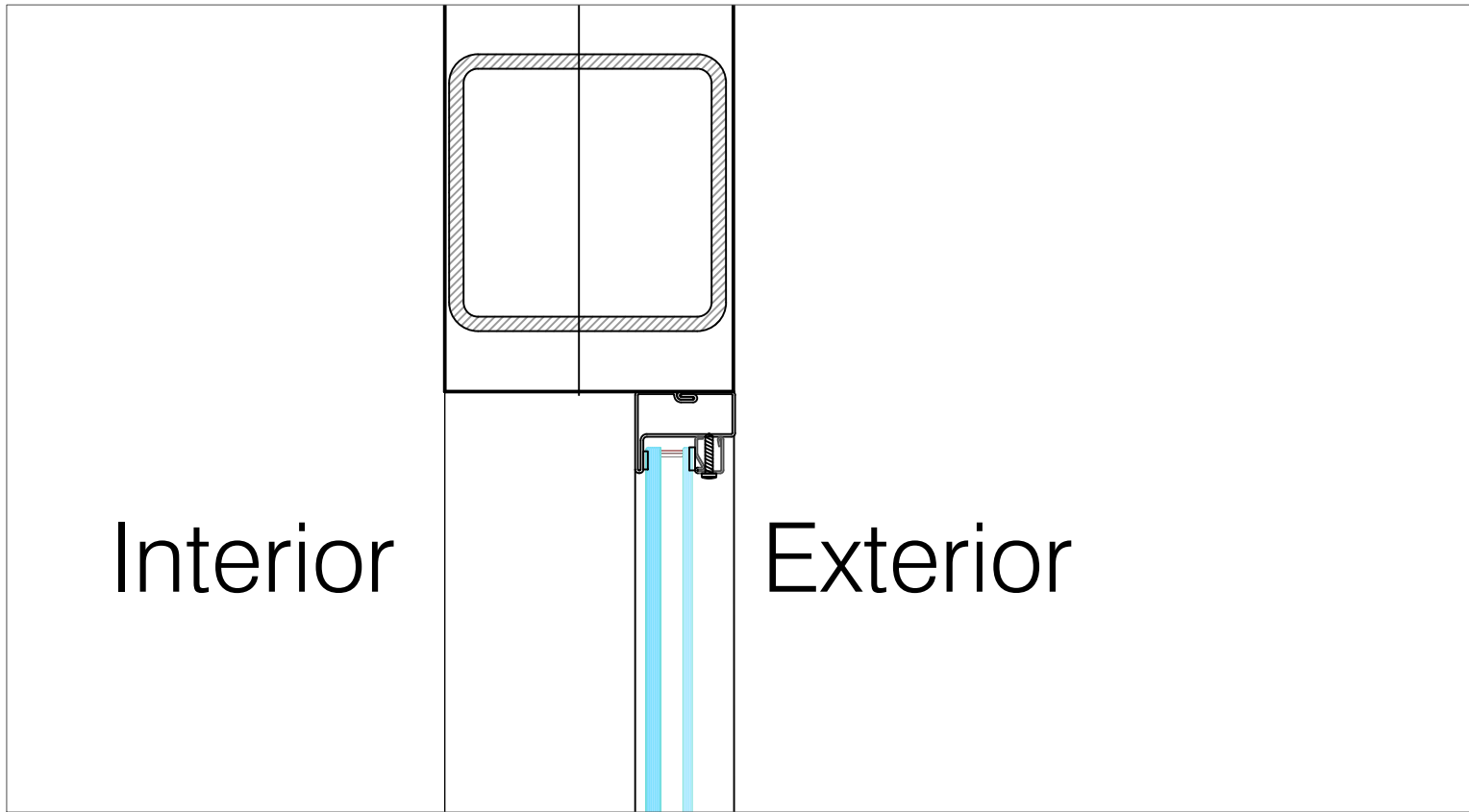

1  
A-17 Glazing Section at Head

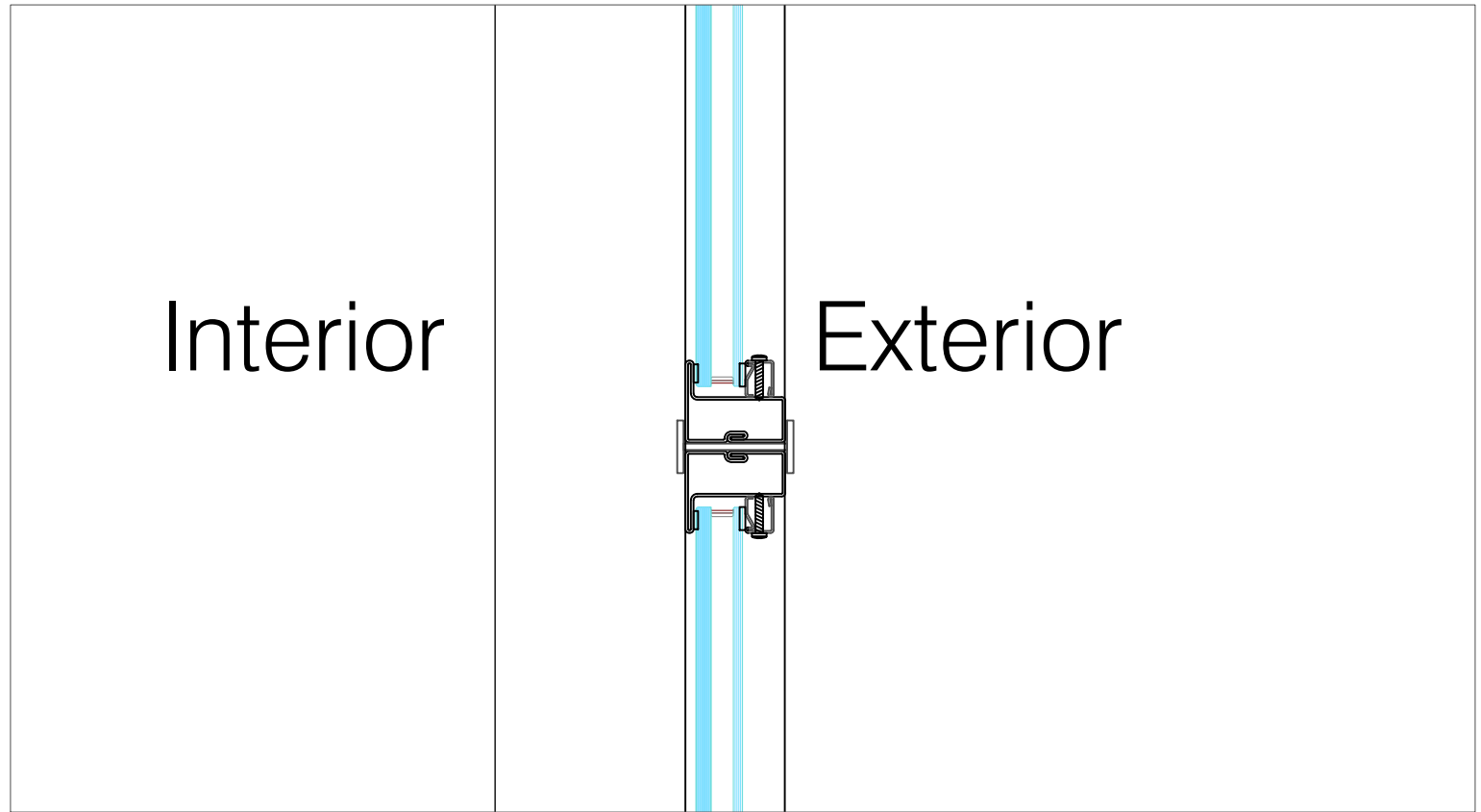

3  
A-17 Glazing Section at Mullion

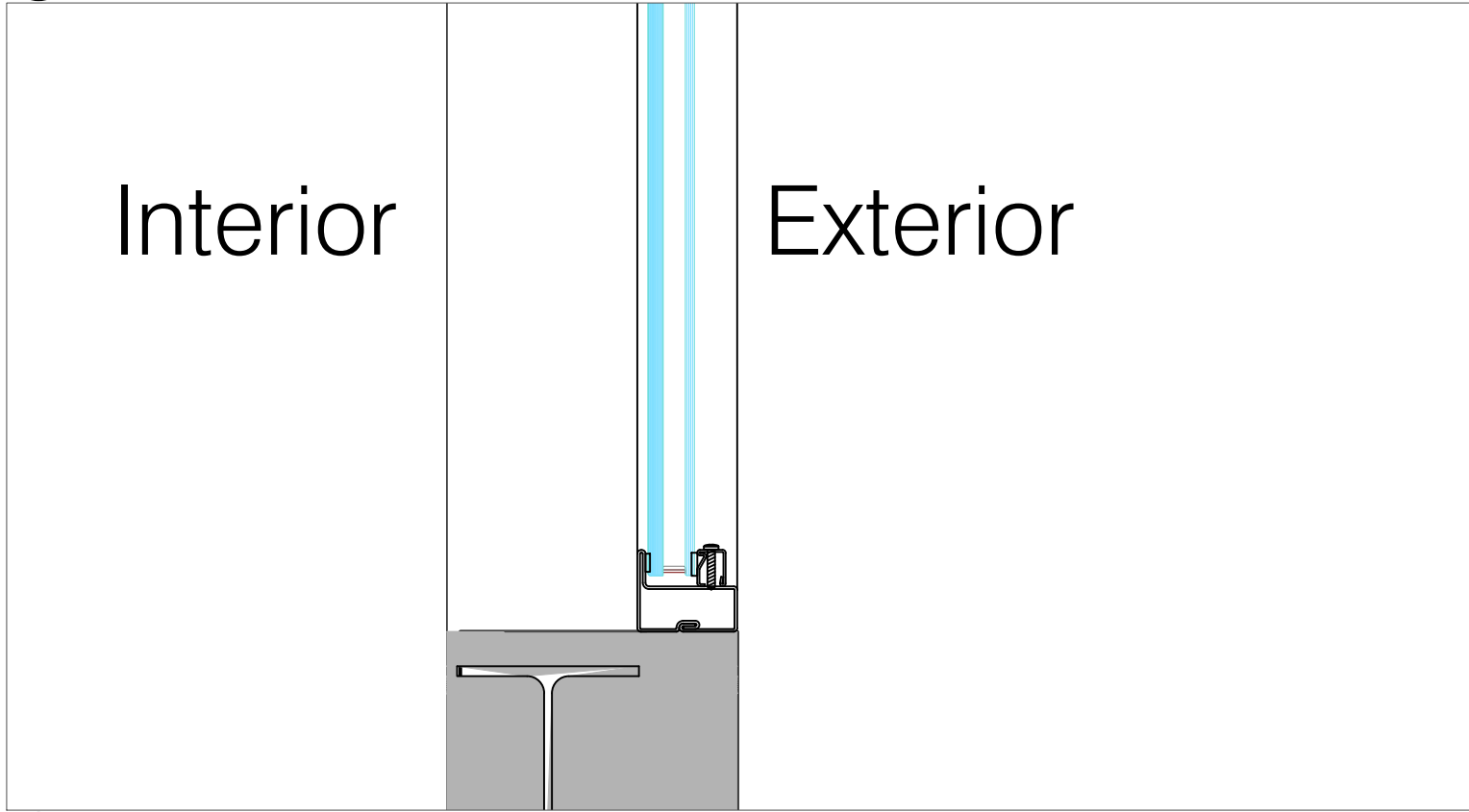

2  
A-17 Glazing Section at Sill

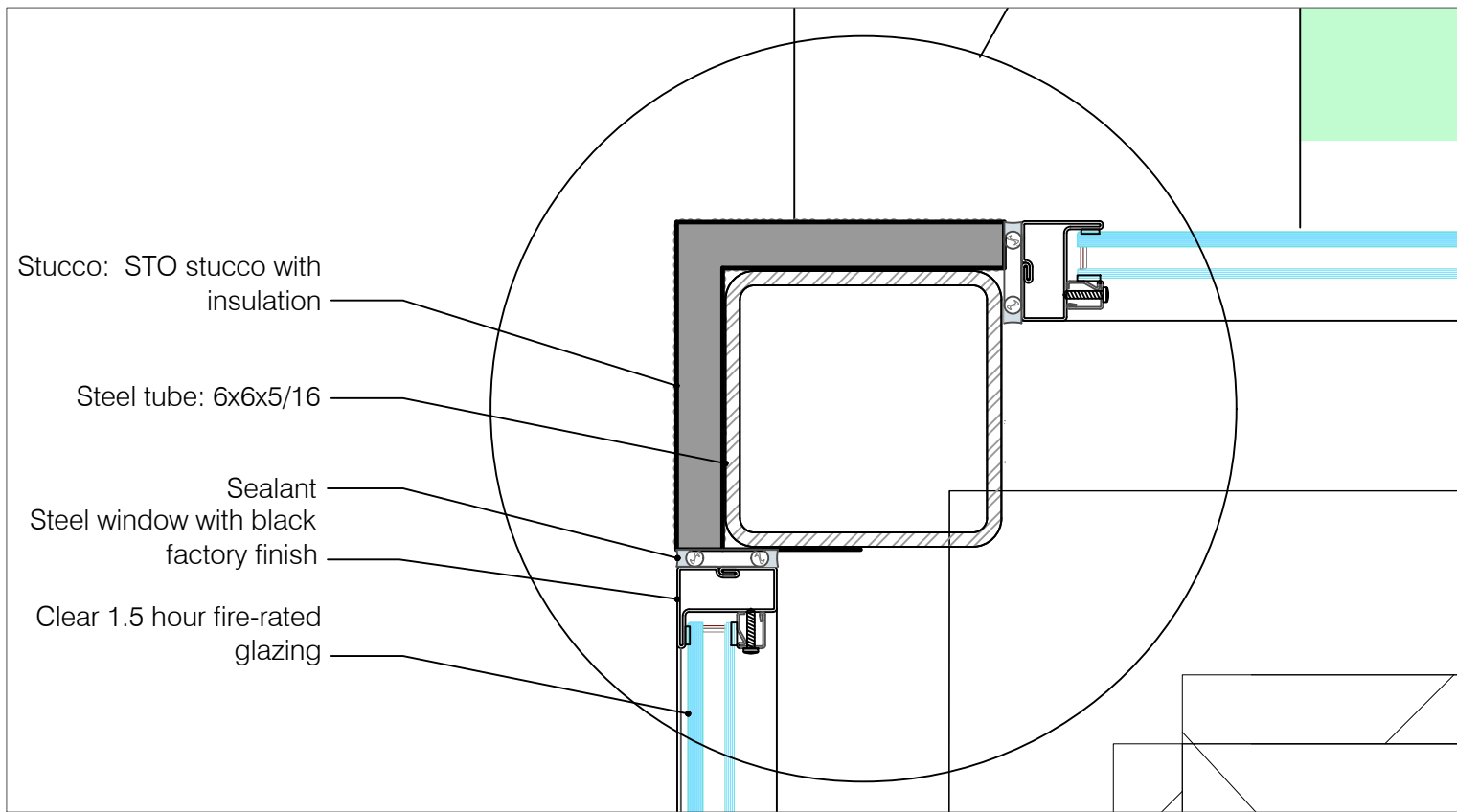

- Stucco: STO stucco with insulation
- Steel tube: 6x6x5/16
- Sealant
- Steel window with black factory finish
- Clear 1.5 hour fire-rated glazing

1  
A-18 Glazing Section at Steel Tube

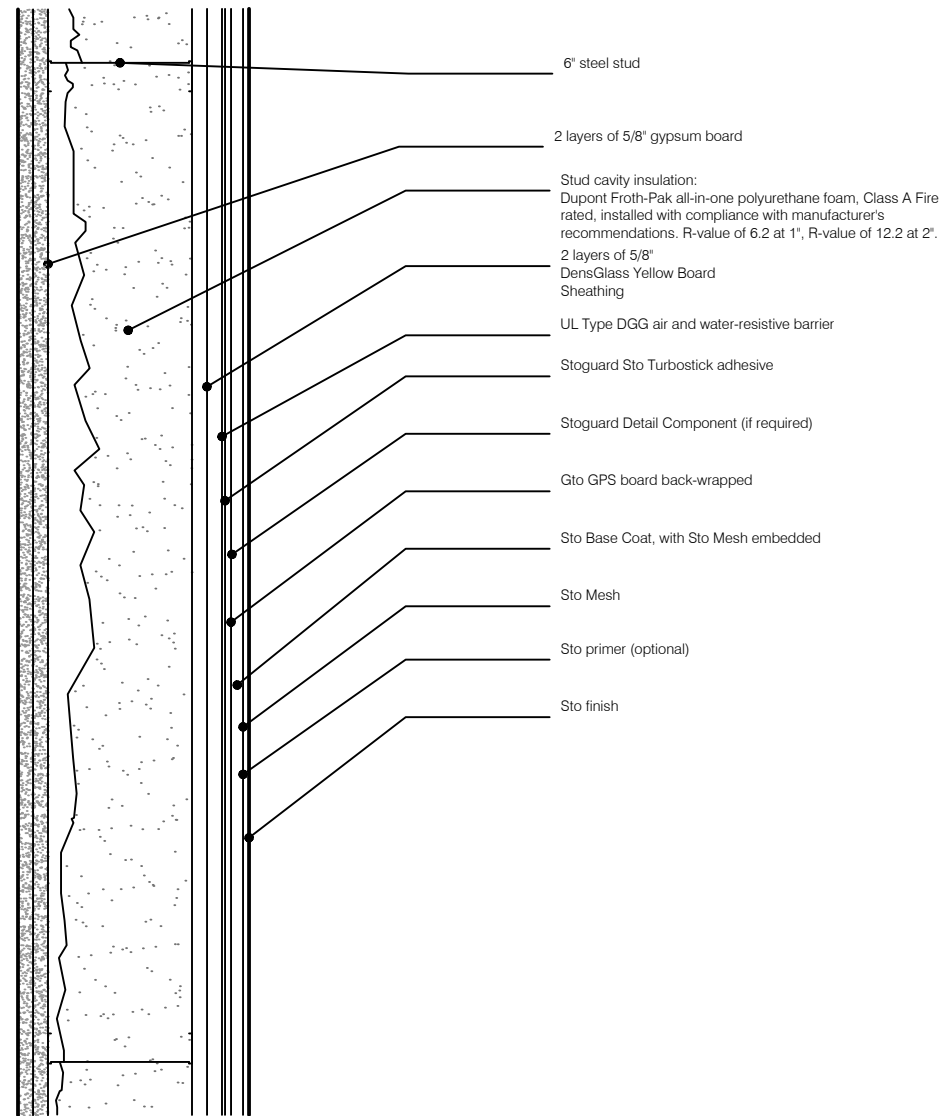

UPPER WALL

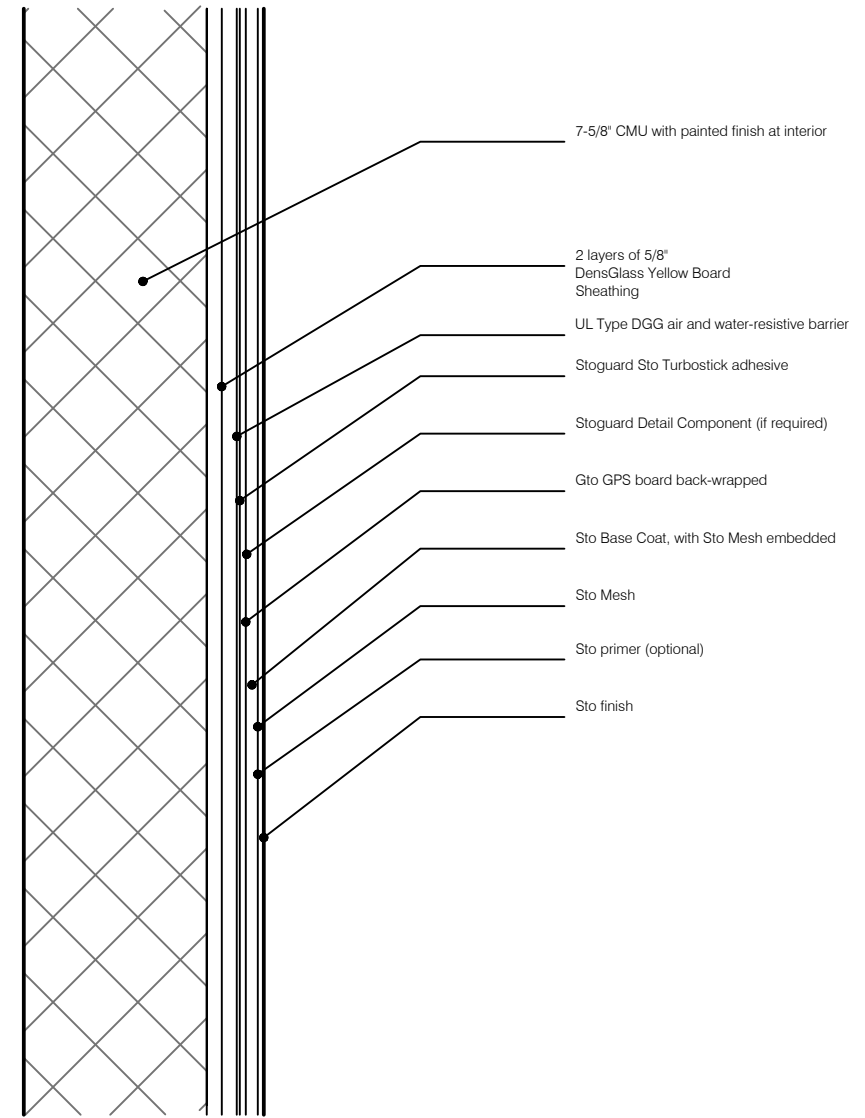

LOWER WALL

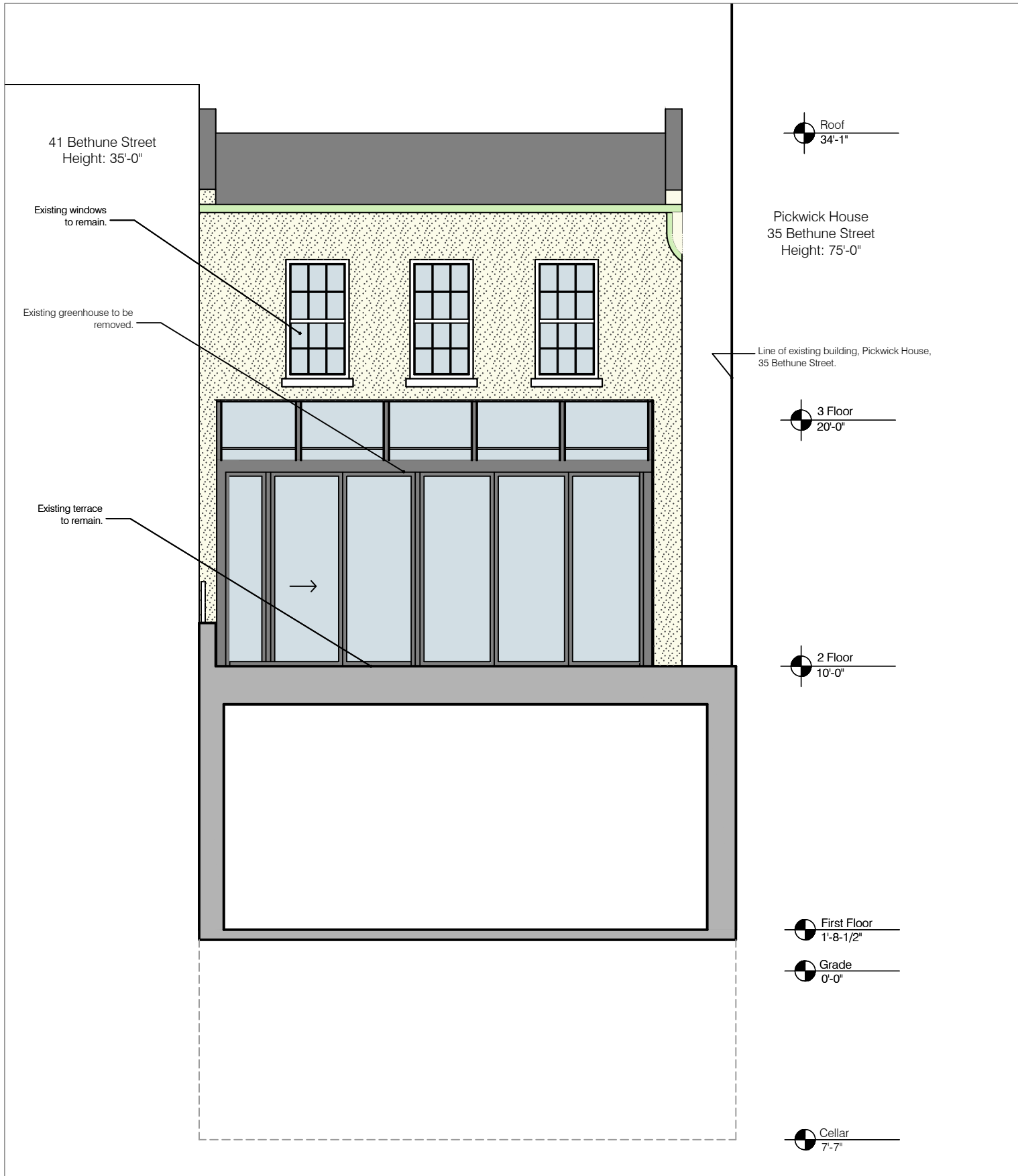

Existing



Proposed

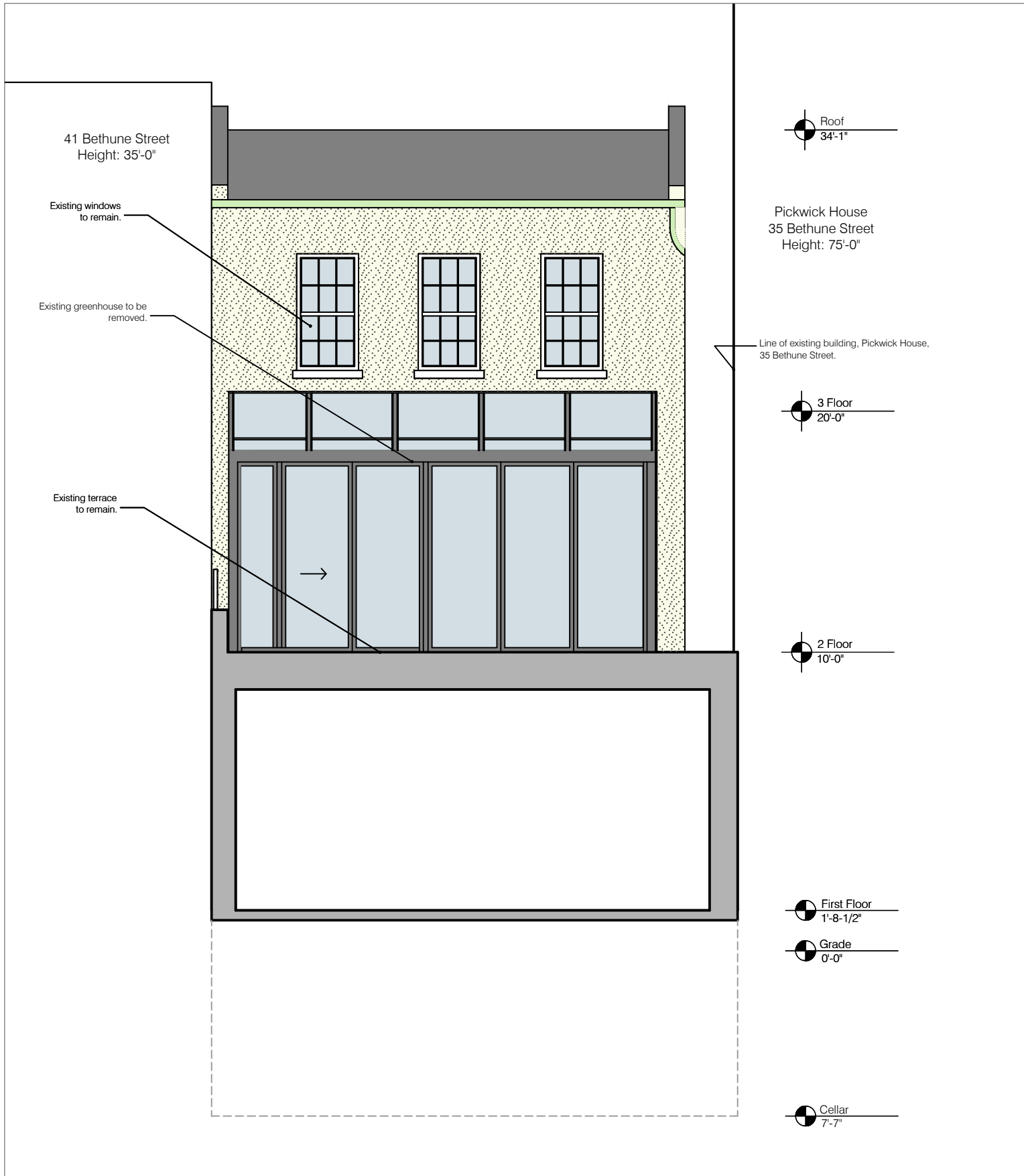

Existing

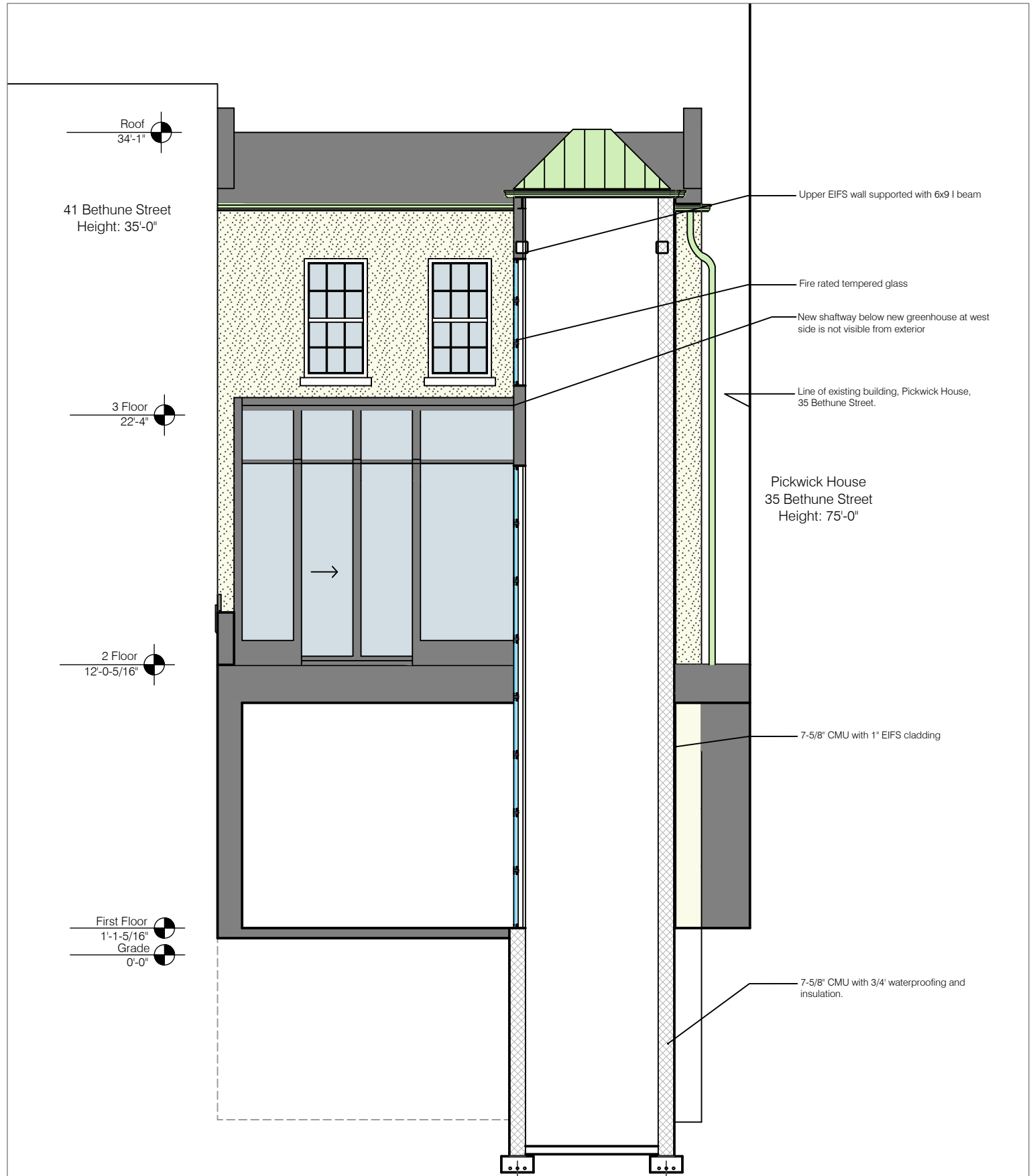

Proposed

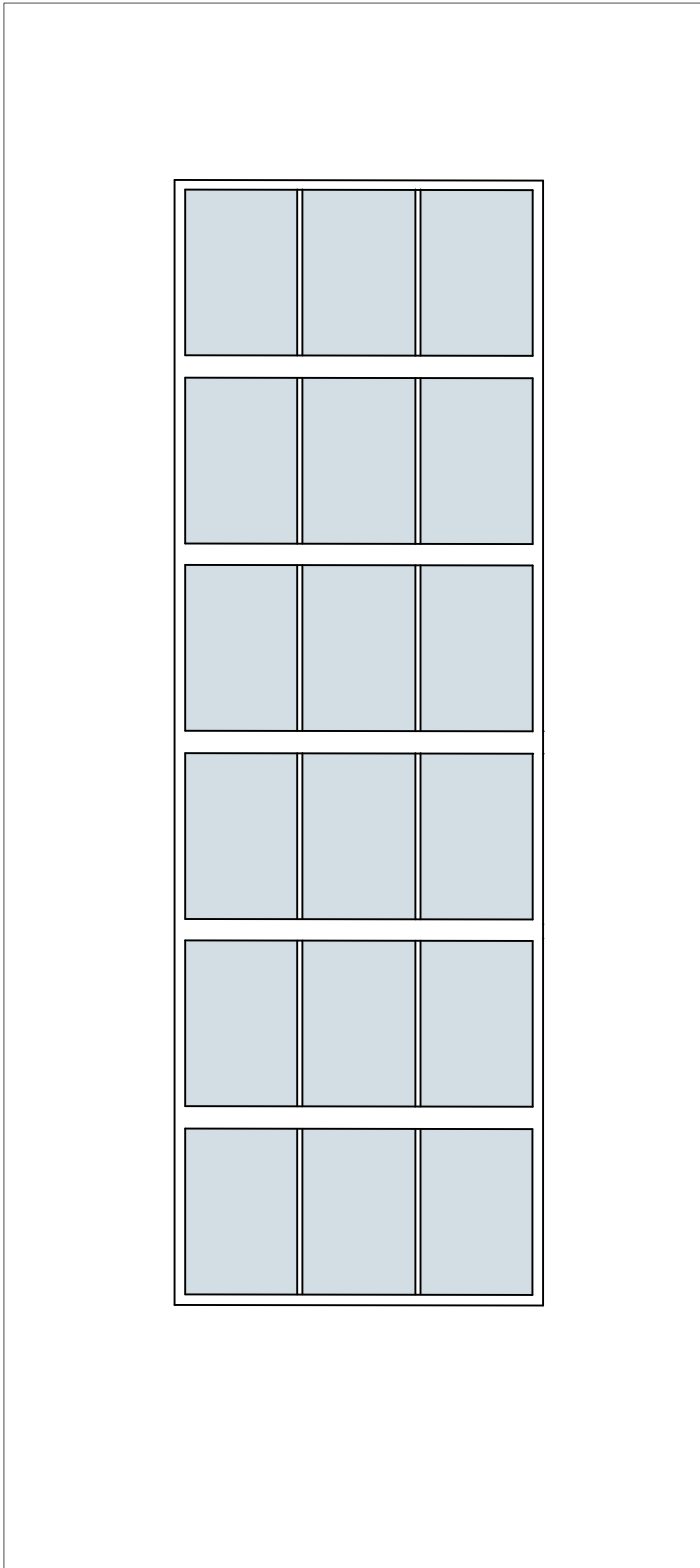

Elevation

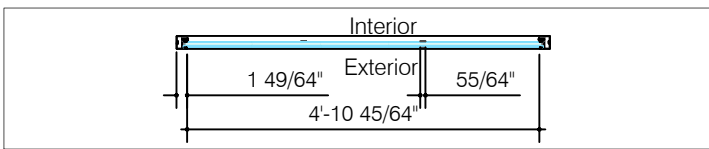

Plan

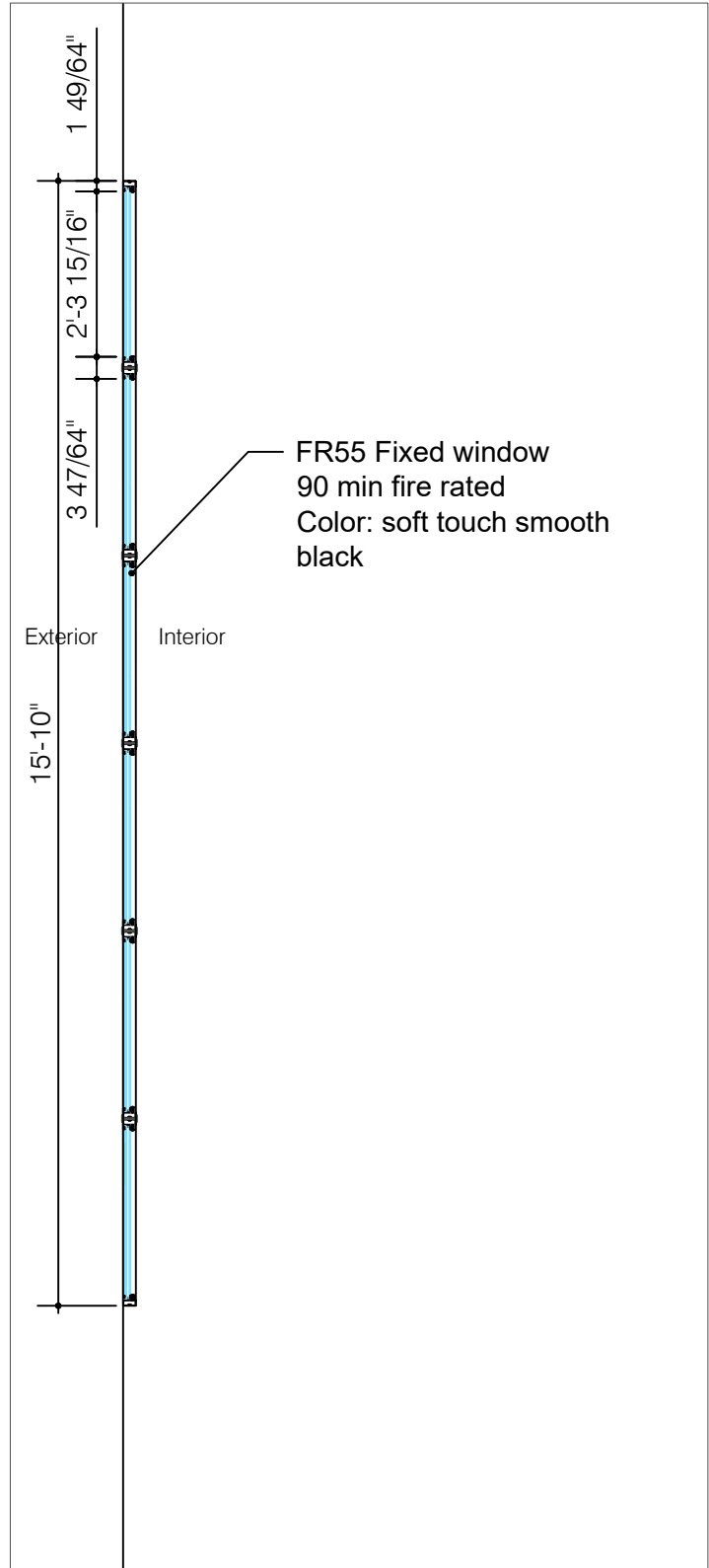

Section

Upper South Window 1

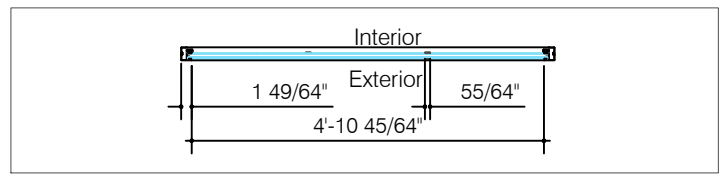
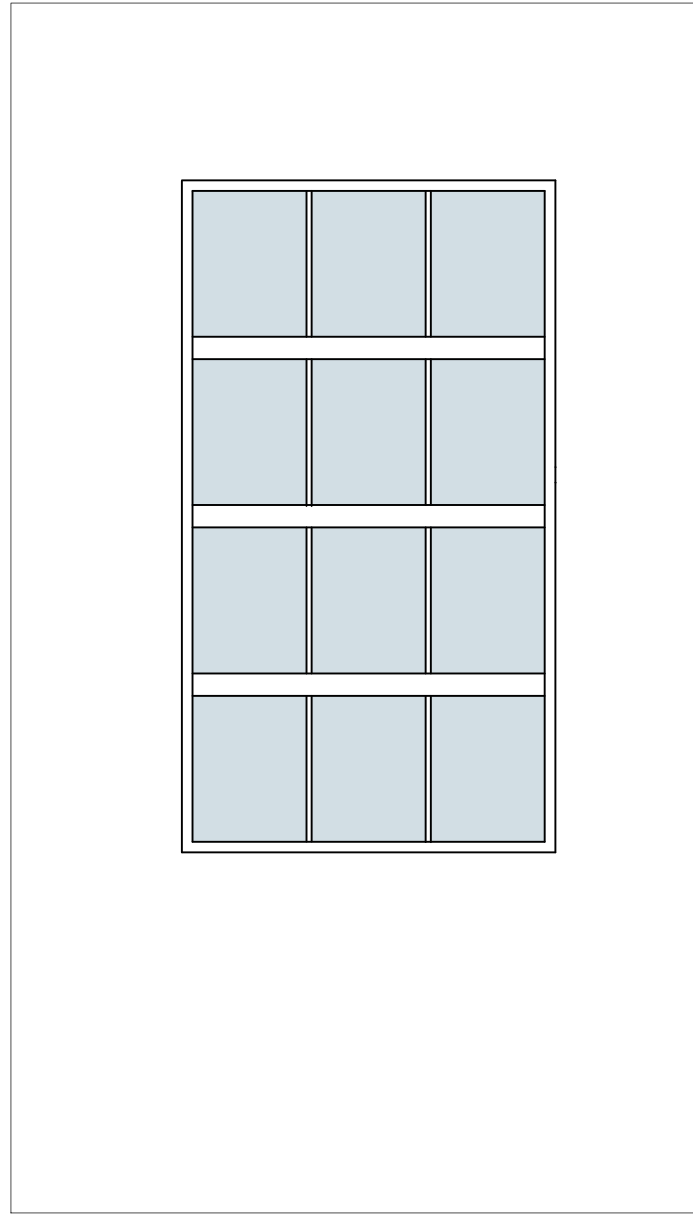

Plan

Glazing Details Windows 1 & 2

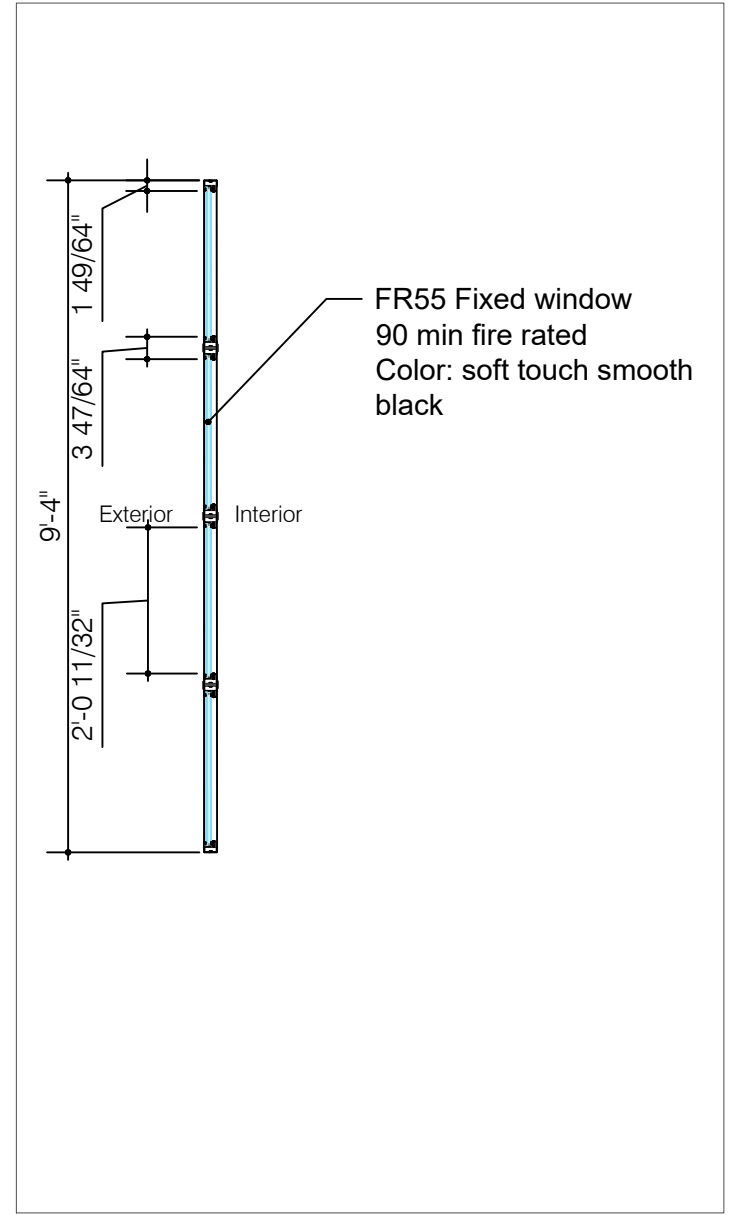

Lower South Window 2

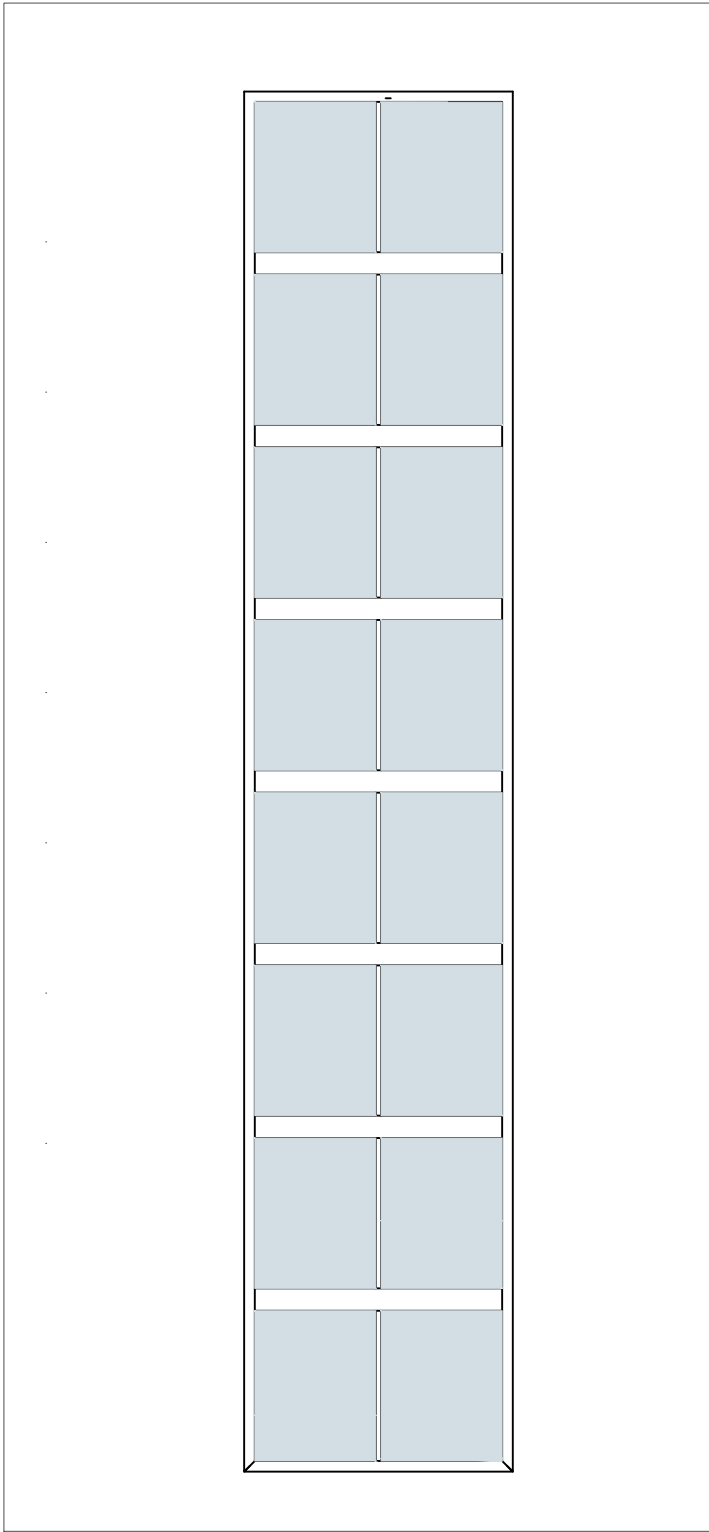

Elevation

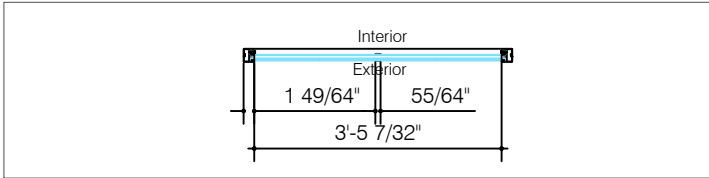

Plan

Charles H. Henkels, AIA  
Architects

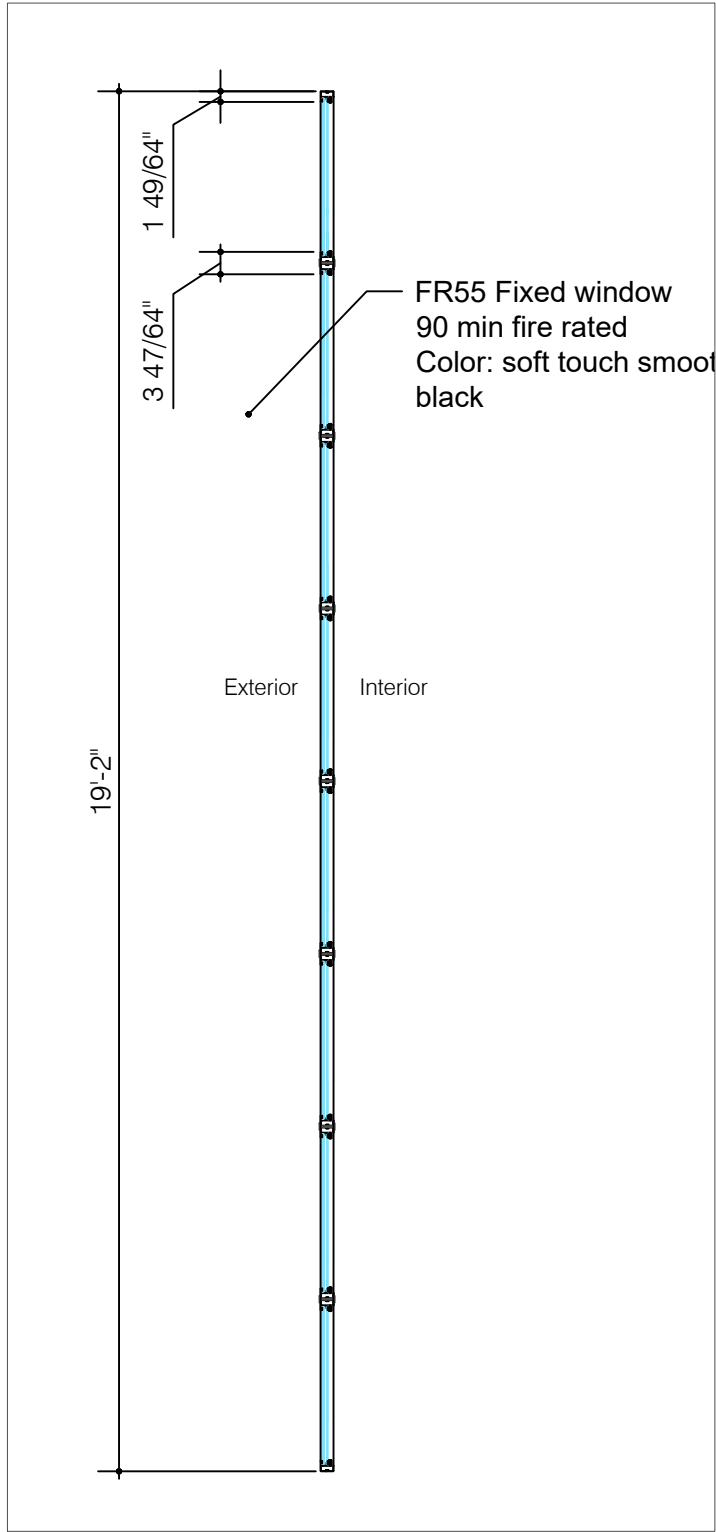

Section

Upper West Window 3

39 Bethune Street  
Greenwich Village Historic District

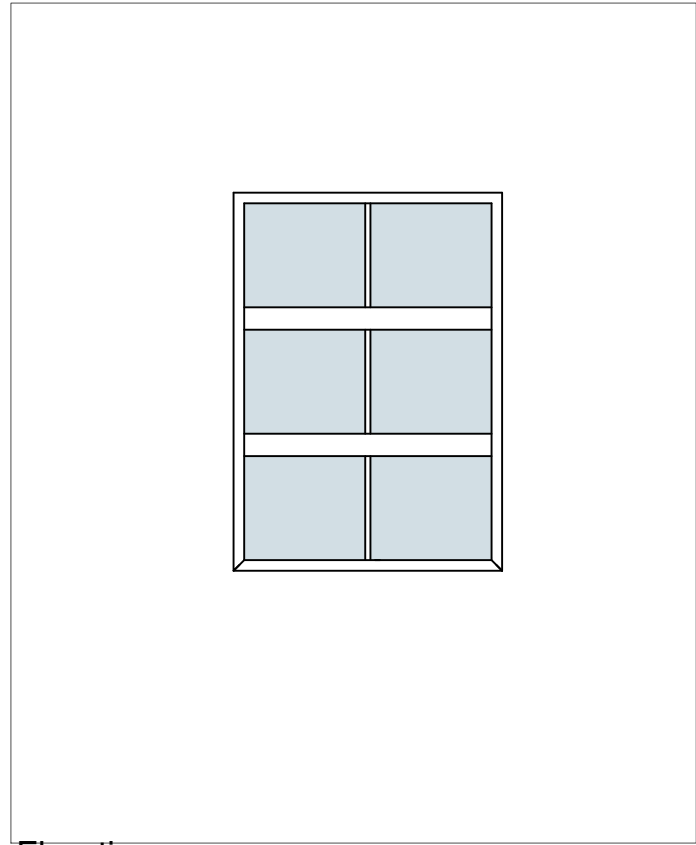

Elevation

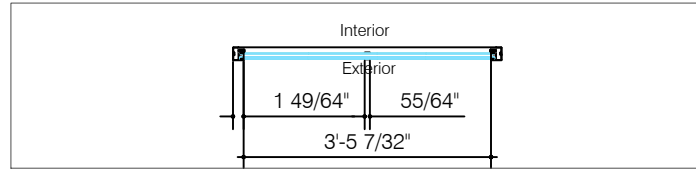

Plan

Glazing Details Windows 3 & 4

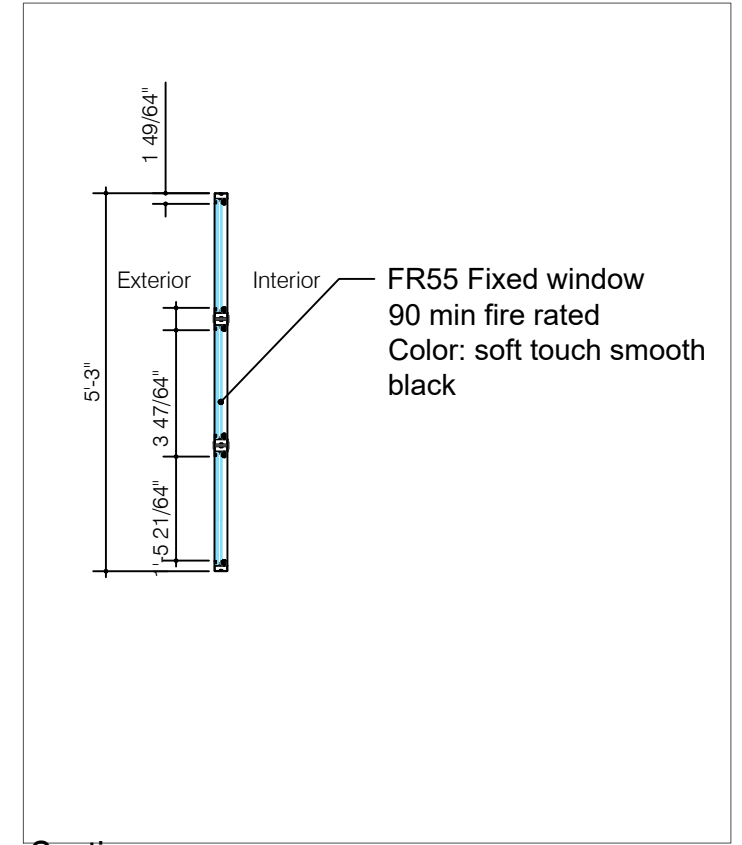

Section

Lower West Window 4



May 19, 2026  
Public Hearing

The current proposal is:

Preservation Department – Item 4, LPC-26-09561

## **39 Bethune Street – Greenwich Village Historic District Borough of Manhattan**

**To testify virtually, please join Zoom**

**Webinar ID:** 165 215 8714

**Passcode:** 958652

By Phone: 646-828-7666 (NY)

833-435-1820 (Toll-free)

833-568-8864 (Toll-free)

**Note:** If you want to testify virtually on an item, join the Zoom webinar at the agenda's "Be Here by" time (about an hour in advance). When the Chair indicates it's time to testify, "raise your hand" via the Zoom app if you want to speak (\*9 on the phone). Those who signed up in advance will be called first.