

May 5, 2026
Public Meeting

The current proposal is:

Preservation Department – Item 2, LPC-26-06719

**61 West 90th Street – Upper West Side/Central Park West
Historic District
Borough of Manhattan**

To testify virtually, please join Zoom

Webinar ID: 161 198 1457

Passcode: 180173

By Phone: 646-828-7666 (NY)

833-435-1820 (Toll-free)

833-568-8864 (Toll-free)

Note: If you want to testify virtually on an item, join the Zoom webinar at the agenda's "Be Here by" time (about an hour in advance). When the Chair indicates it's time to testify, "raise your hand" via the Zoom app if you want to speak (*9 on the phone). Those who signed up in advance will be called first.

61 WEST 90TH STREET
NEW YORK, NY 10024

AREAWAY

LANDMARKS PRESERVATION COMMISSION
PUBLIC HEARING
05.05.2026

Upper West Side/Central Park West Historic District | LP-1647

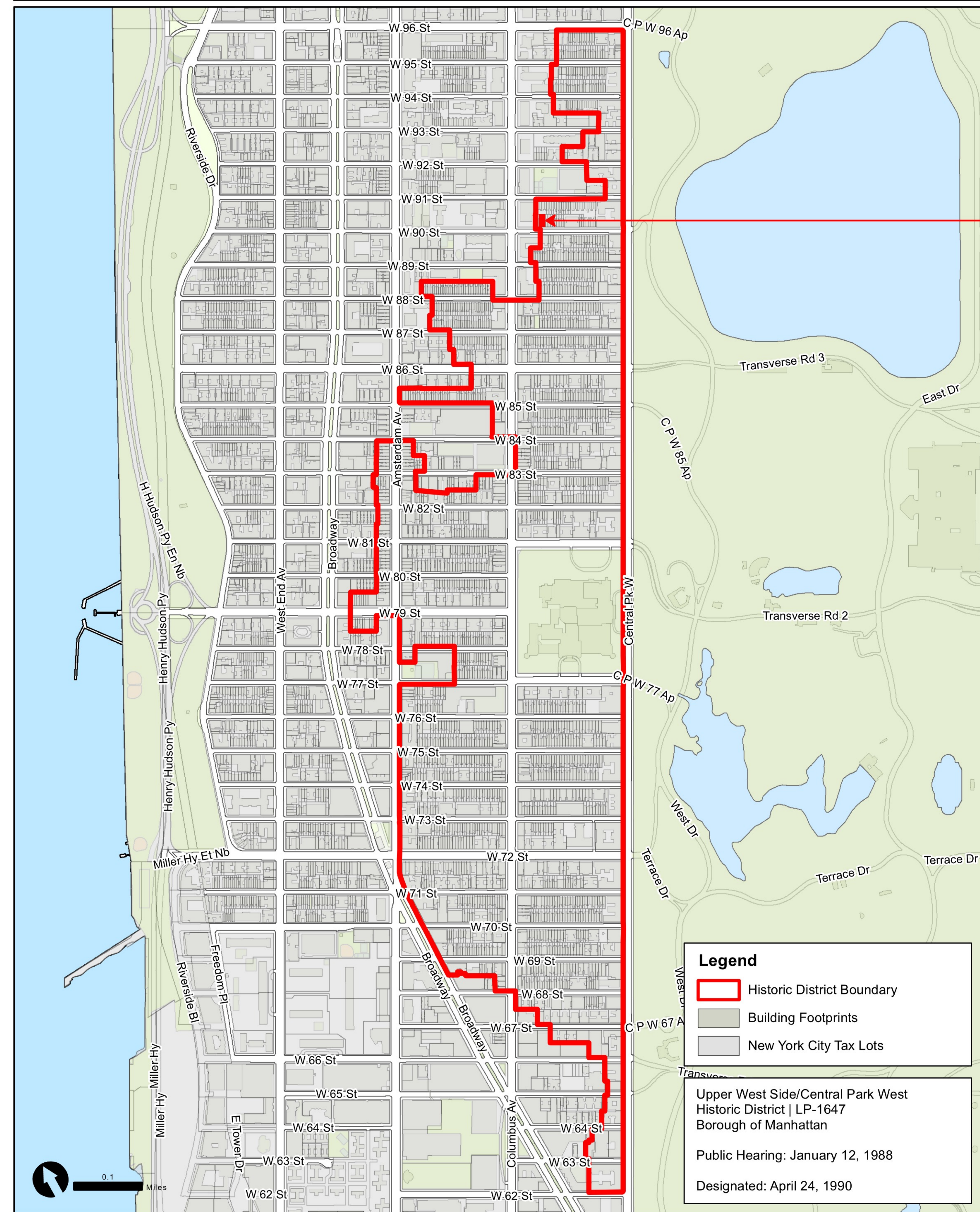

61 W 90TH ST

Legend

- Historic District Boundary
- Building Footprints
- New York City Tax Lots

Upper West Side/Central Park West
 Historic District | LP-1647
 Borough of Manhattan
 Public Hearing: January 12, 1988
 Designated: April 24, 1990

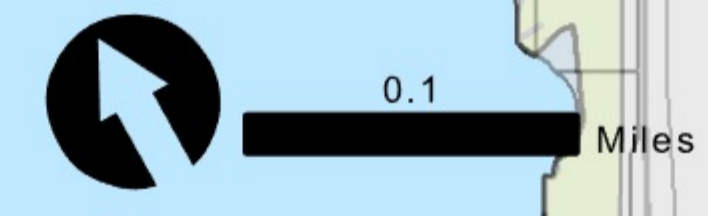

Graphic Source: Map PLUTO, Edition 18v1, Author: New York City Landmarks Preservation Commission, LCR Date: 3.28.2019



61 W 90TH ST



TAX PHOTO - 1940
SOURCE: MUNICIPAL ARCHIVES



61 W 90TH ST



DESIGNATION PHOTO - 1990
SOURCE: UWS HISTORIC DISTRICT DESIGNATION REPORT



PROPOSED AREA OF WORK



CURRENT CONDITION - 2026

BASEMENT ENTRY // SCOPE OF WORK

**EXISTING CONDITION****PROPOSED SCOPE OF WORK**

- CREATE NEW BROWNSTONE STUCCO PIERS
- CREATE NEW BASEMENT ENTRY GATE FROM EXISTING IRONWORK
- RESURFACE BROWNSTONE NEWEL POSTS
- REUSE/RECONFIGURE EXISTING RAILING INTO NEW SIDE RAILS

63 W 90TH



61 W 90TH



59 W 90TH



57 W 90TH



NEIGHBORING CONTEXT

- BUILDINGS ARE ENTERED AT BASEMENT LEVEL
- STOOPS WERE LONG AGO REMOVED
- FRONT YARDS ARE DEFINED WITH LOW BROWNSTONE WALLS AND ORNAMENTAL RAILINGS



PORTION OF EXISTING CHEEK WALLS TO BE REMOVED



ALL SURFACES ARE STUCCO
(NO ORIGINAL BROWNSTONE)



PROPOSED NEWEL RESURFACING



EXSITING NEWEL AND SIDEWALK GATE. GATE TO REMAIN.

63 W 90TH



57 W 90TH



55 W 90TH



NEIGHBORING RETAINING WALLS AND ORNAMENTAL RAILING RETURNS

ORNAMENTAL RAILING ELEMENTS TO BE REUSED

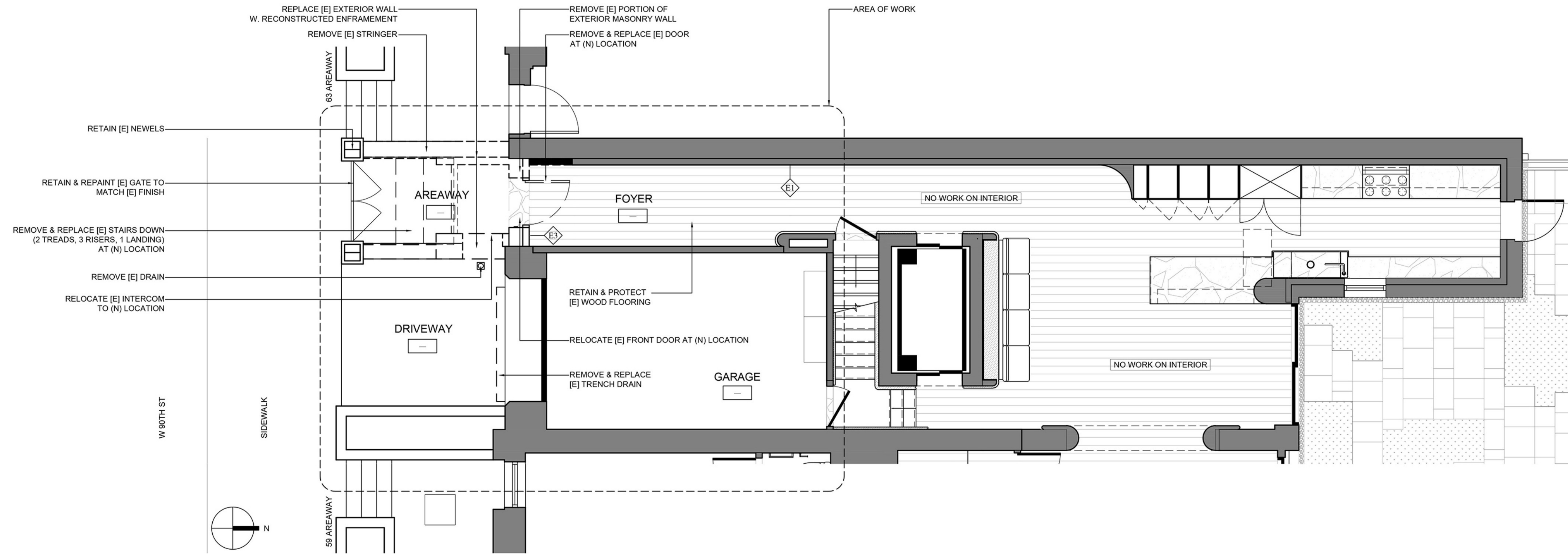

SCOPE OF REMOVAL // BASEMENT LEVEL

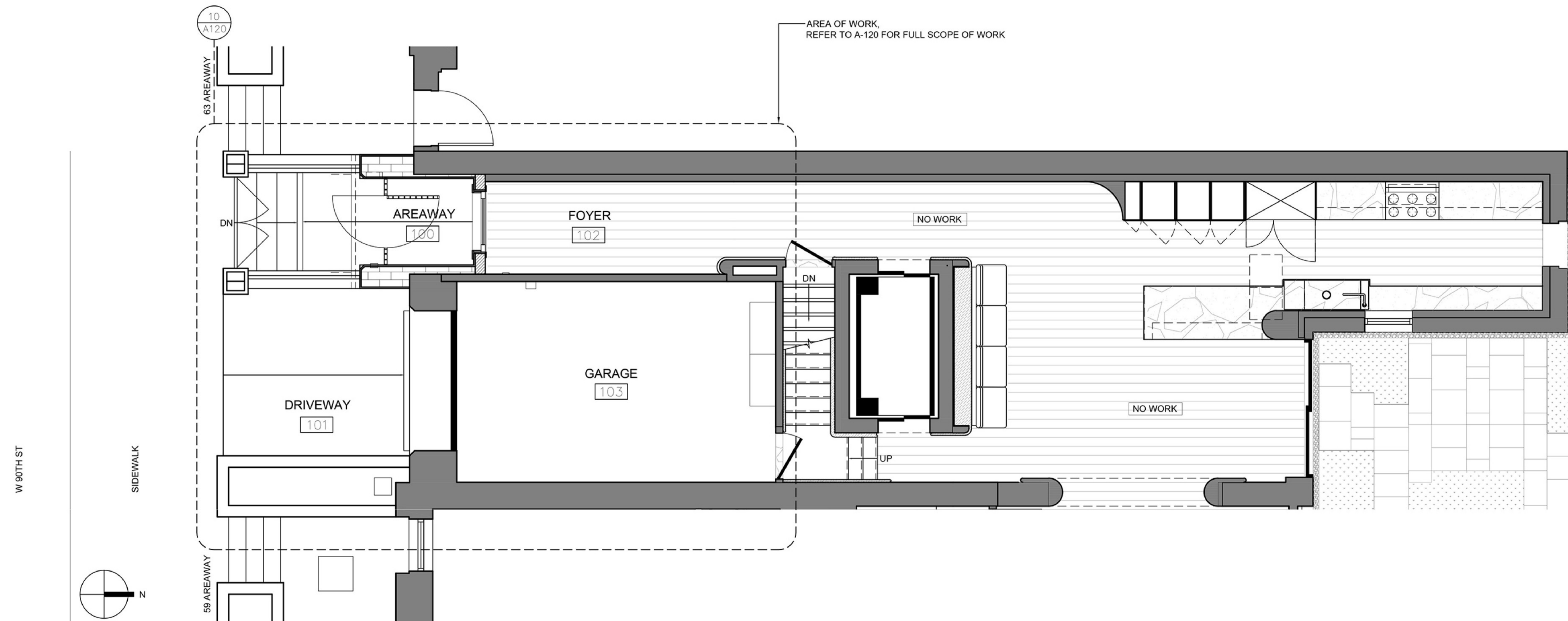

PROPOSED WORK // BASEMENT LEVEL

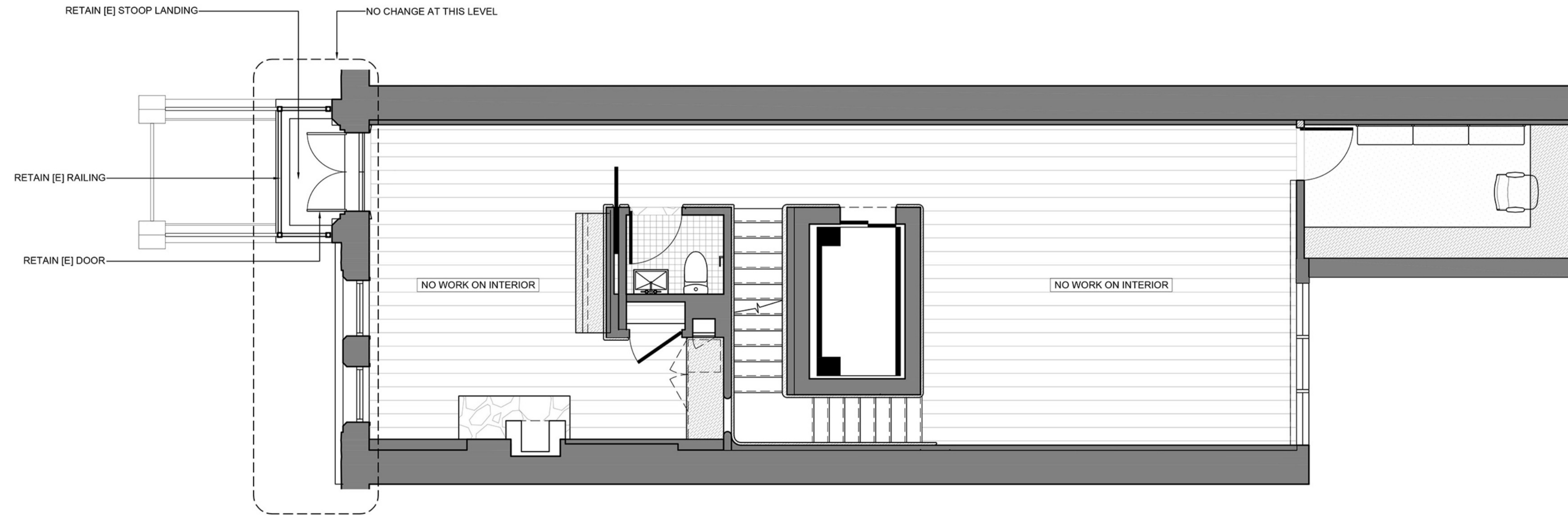

SCOPE OF REMOVAL // FIRST FLOOR LEVEL

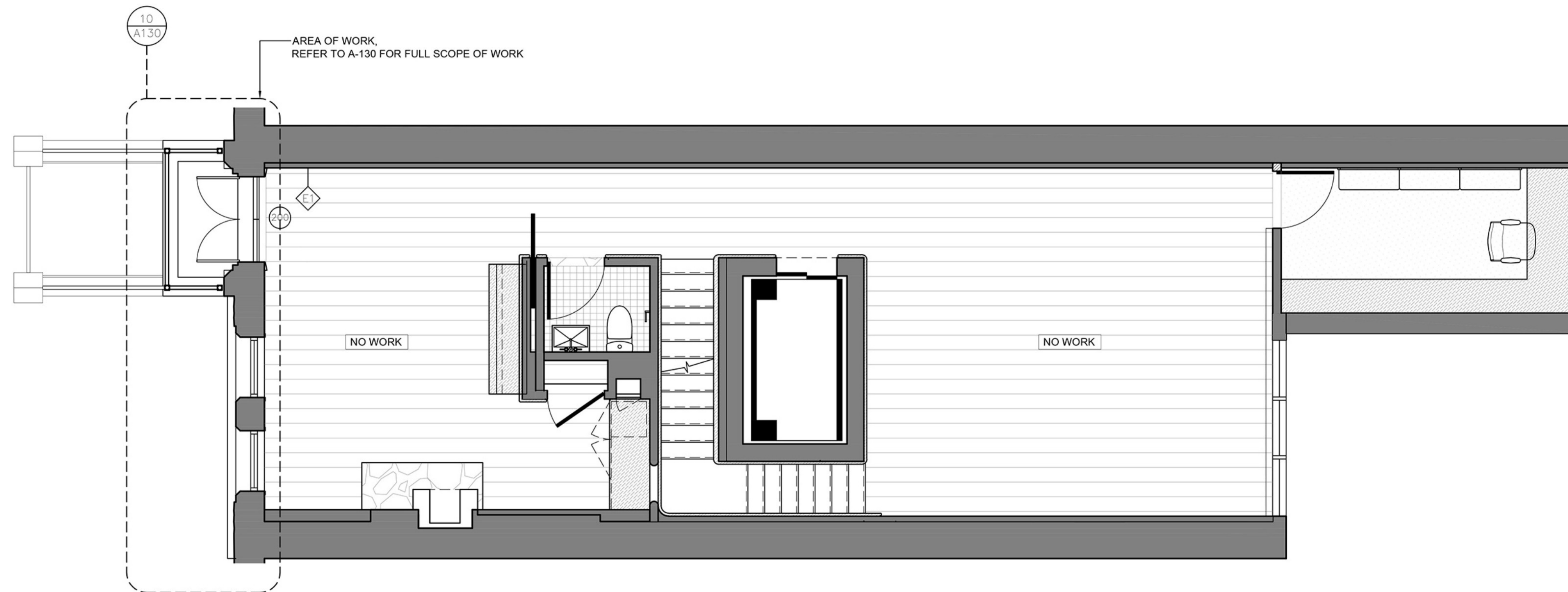

PROPOSED WORK // FIRST FLOOR LEVEL



STREET ELEVATION // EXISTING



STREET ELEVATION // PROPOSED



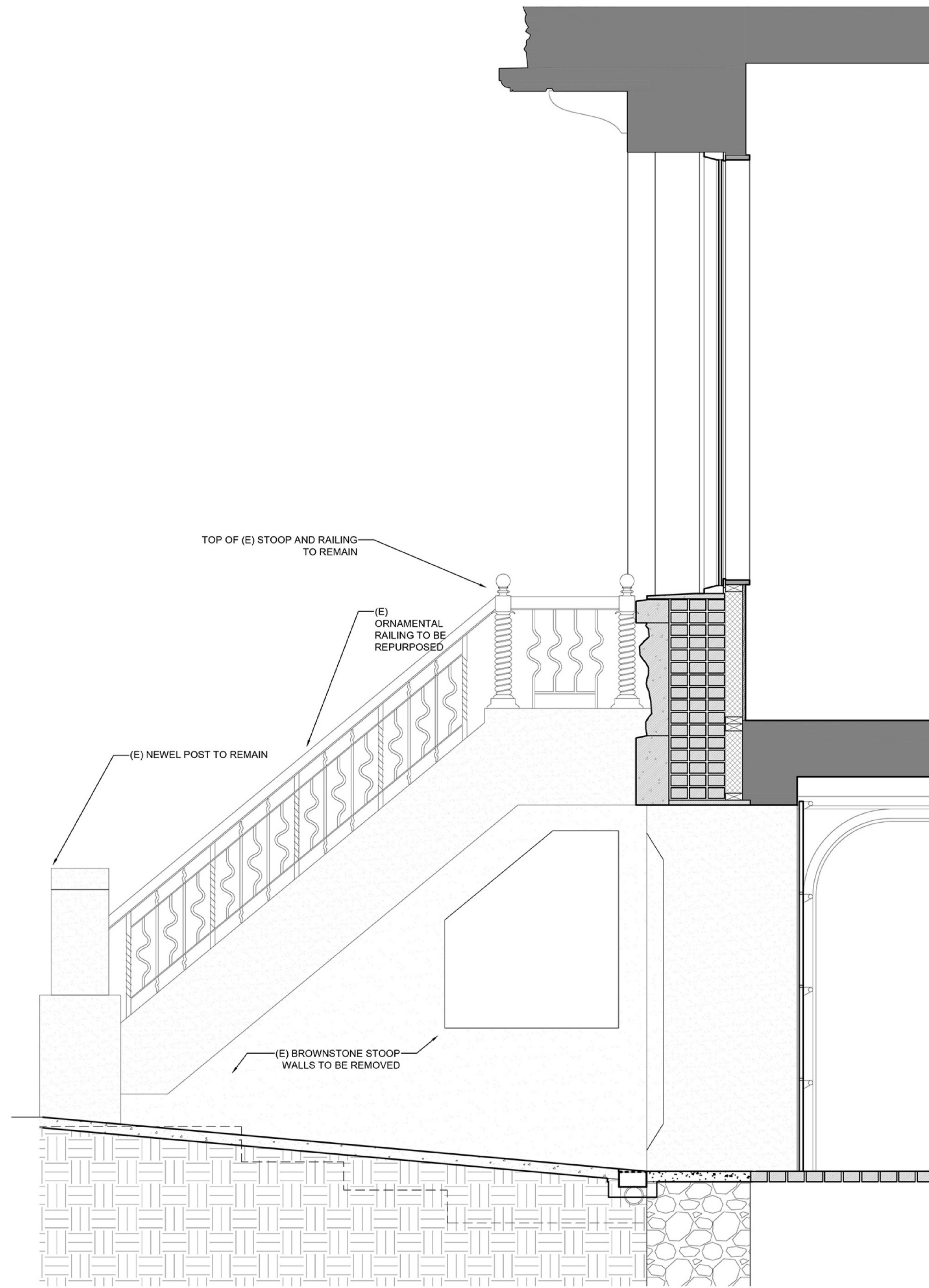

EXISTING CONDITION

DETAIL SECTIONS // @GARAGE

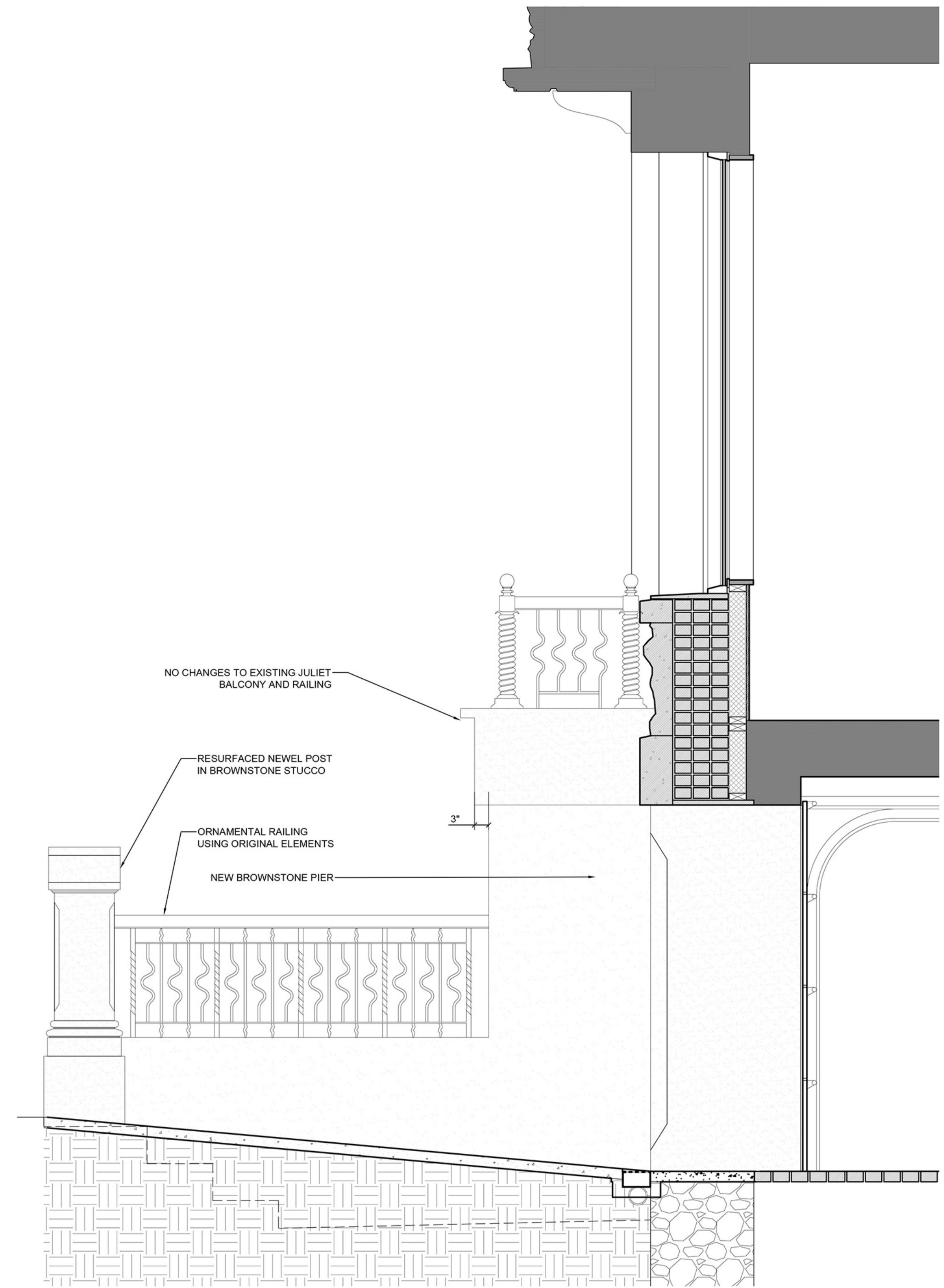

PROPOSED ALTERATION

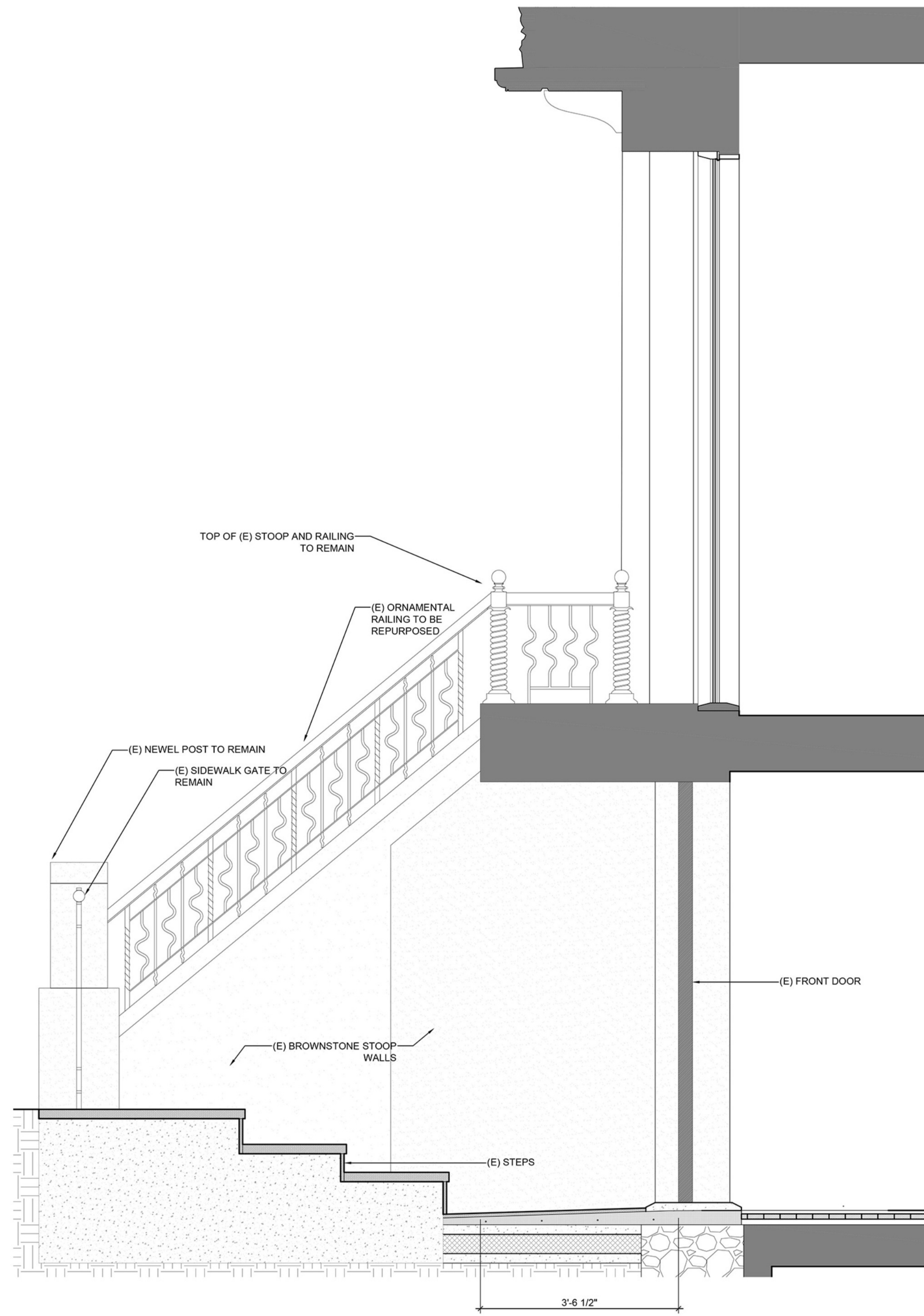

EXISTING CONDITION
DETAIL SECTIONS // @AREAWAY

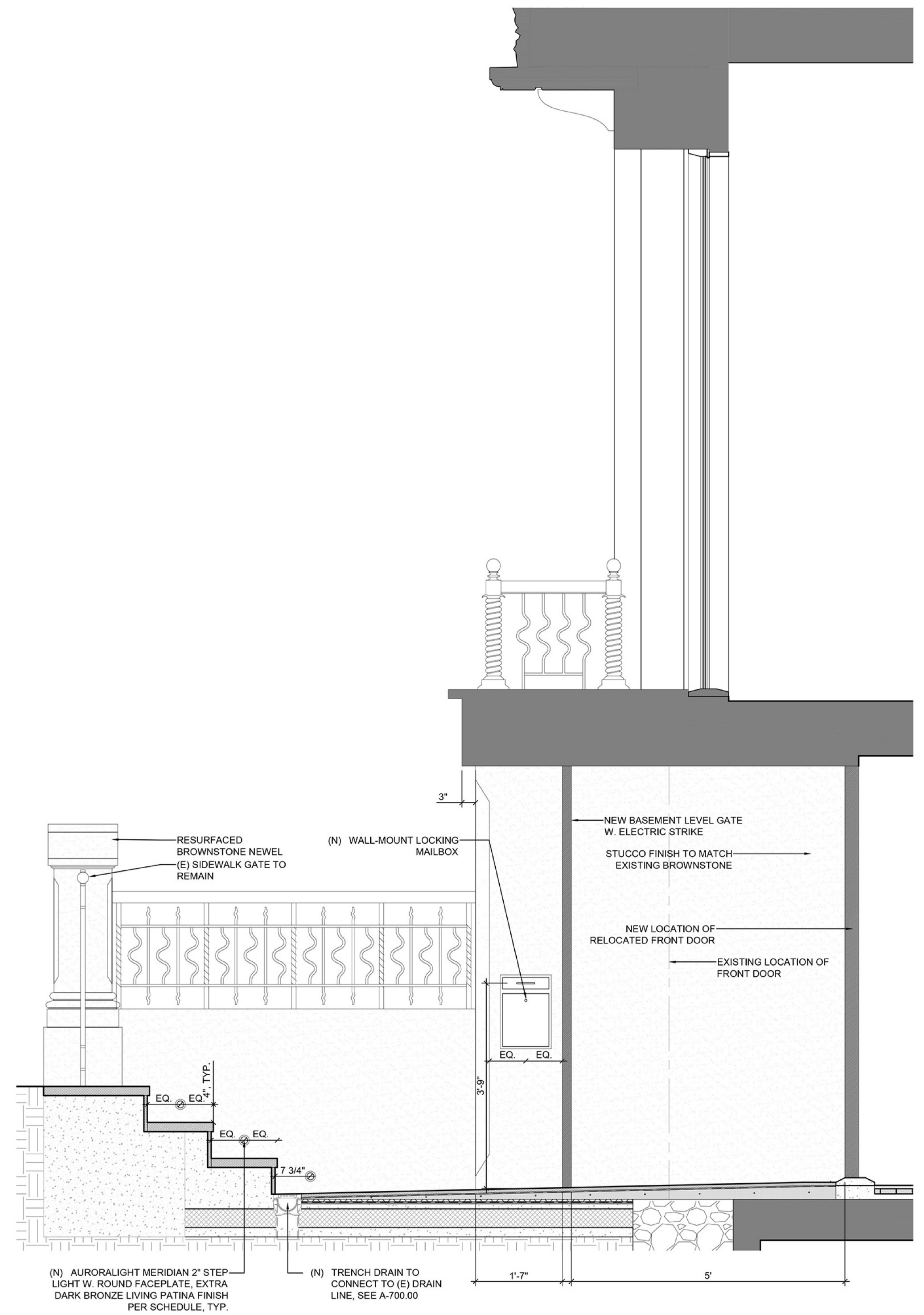

PROPOSED ALTERATION

May 5, 2026
Public Meeting

The current proposal is:

Preservation Department – Item 2, LPC-26-06719

**61 West 90th Street – Upper West Side/Central Park West
Historic District
Borough of Manhattan**

To testify virtually, please join Zoom

Webinar ID: 161 198 1457

Passcode: 180173

By Phone: 646-828-7666 (NY)

833-435-1820 (Toll-free)

833-568-8864 (Toll-free)

Note: If you want to testify virtually on an item, join the Zoom webinar at the agenda's "Be Here by" time (about an hour in advance). When the Chair indicates it's time to testify, "raise your hand" via the Zoom app if you want to speak (*9 on the phone). Those who signed up in advance will be called first.

61 WEST 90TH STREET
NEW YORK, NY 10024

AREAWAY (APPENDIX)

LANDMARKS PRESERVATION COMMISSION
PUBLIC HEARING
05.05.2026

LEGEND



RAILING REMNANTS
 PREVIOUSLY REMOVED STOOP STAIR
 NEWEL REMNANTS
 INADEQUATE AREAWAY DRAINAGE CAUSING WATER INFILTRATION
 SPALLING CONCRETE TOPPING SLAB

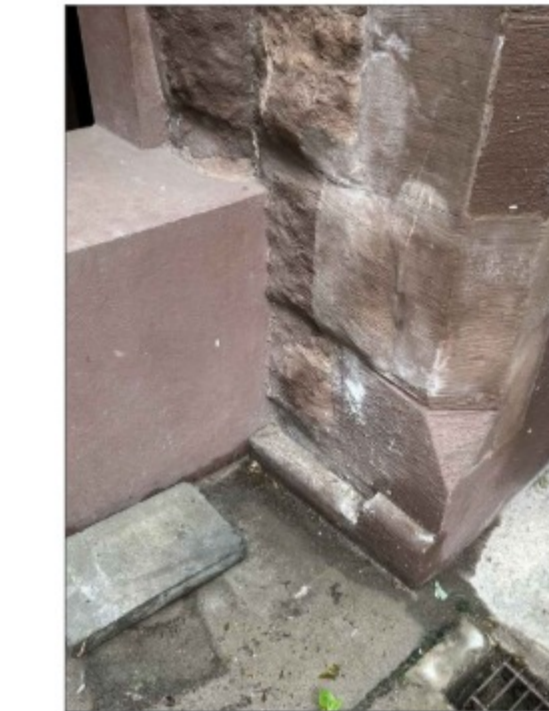

DAMAGED PARTS THROUGHOUT THE FACADE MKCA RECORDS 30

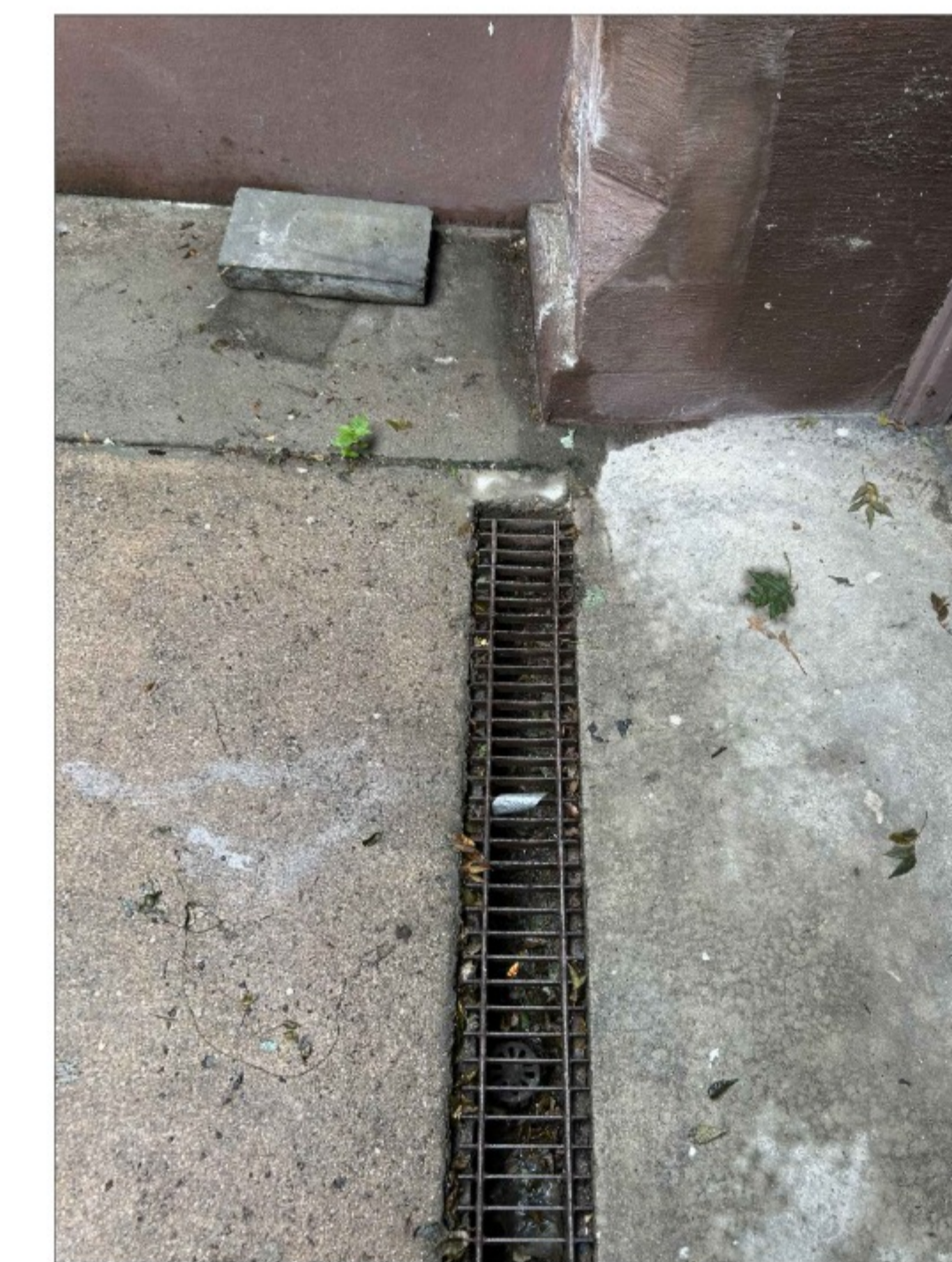

DRAINAGE CONDITION @ DRIVEWAY MKCA RECORDS 20



CURRENT WATER ISSUES @ AREAWAY MKCA RECORDS 10

CURRENT CONDITION PHOTO - 2025 MKCA RECORDS 40

SCOPE OF WORK AT AREAWAY & DRIVEWAY - SUMMARY

THE PROPOSED SCOPE OF WORK ADDRESSES THREE EXISTING CONDITIONS:
 1. WORK TO ADDRESS DRAINAGE AND WATERPROOFING AT THE GROUND PLANE: AREAWAY AND DRIVEWAY DRAINS DAMAGE, NEW TRENCH DRAIN CONNECTED TO EXISTING STORM LINE, NEW RECONFIGURED STEPS, REPAVING THE AREAWAY AND STAIRS FROM THE SIDEWALK AS WELL AS THE DRIVEWAY, SEE 10-20/LPC-103;
 2. BRINGING DESIGN RESOLUTION TO NONSENSICAL AND A-HISTORICAL PREVIOUS WORK THAT PARTIALLY DEMOLISHED THE ORIGINAL STOOP, THROUGH THE REPURPOSING OF EXISTING METALWORK, NEWELS AND ORIGINAL DETAILS, RELOCATION OF THE EXISTING ENTRY DOOR, AND NEW BROWNSTONE ENFRAMEMENT WITH REPURPOSED METALWORK AT NEW GATE, SEE 40/LPC-103;
 3. NECESSARY REPAIRS TO EXISTING ELEMENTS: DAMAGED PAVEMENT, BAD STUCCO CONDITION, GARAGE DOOR REFINISHING, EXISTING NEWELS AND GATE MAINTENANCE, SEE 30/LPC-103 & LPC-104

03/24/2026 ISSUED FOR LPC SUBMISSION
 01/02/2026 ISSUED FOR LPC SUBMISSION

Number	Date	Description	Issued to
CONTRACTOR			
TBD			
-			
-			

ARCHITECT
// MKCA //
 MICHAEL K. CHEN ARCHITECTURE, PLLC
 1239 BROADWAY, SUITE 600
 NEW YORK, NY 10001
 (212) 732-0060
 eastcoast@mkca.com

PROJECT
90TH STREET AREAWAY
 61 West 90th St, New York, NY 10024

**FRONT FACADE
 SCOPE OF WORK**

SEAL AND SIGNATURE DATE: 03/24/2026
 PROJECT NO: 25_61 W 90TH ST
 DWG NO:

LPC-103.00

SHEET:
 7 OF 30

LEGEND



EXISTING CONCRETE RETAINING WALL & RAILING RETURN @ 63 W 90TH ST
MKCA RECORDS 50



EXISTING CONCRETE RETAINING WALL & RAILING RETURN @ 57 W 90TH ST
MKCA RECORDS 40



EXISTING CONCRETE RETAINING WALL & RAILING RETURN @ 55 W 90TH ST
MKCA RECORDS 30

AREAWAY AND DRIVEWAY PAVEMENT SLABS TO BE REMOVED, BOTH TO BE REPLACED WITH BLUE STONE PAVING. NEW STEPS TO BE FINISHED TO MATCH STUCCO, AS IN THE AREAWAY OF THE NEIGHBORING 55 W 90TH ST



EXISTING STUCCO STEPS & BLUE STONE PAVING @ 55 W 90TH ST
MKCA RECORDS 20



EXISTING CONCRETE STEPS & PAVEMENT @ 61 W 90TH ST
MKCA RECORDS 10



03/24/2026 ISSUED FOR LPC SUBMISSION

Number	Date	Description	Issued to
CONTRACTOR			
TBD			
-			
-			

ARCHITECT
// MKCA //
 MICHAEL K. CHEN ARCHITECTURE, PLLC
 1239 BROADWAY, SUITE 600
 NEW YORK, NY 10001
 (212) 732-0060
 eastcoast@mkca.com

PROJECT
90TH STREET AREAWAY
 61 West 90th St, New York, NY 10024

**FRONT FACADE
 PAVING & RETAINING WALLS**

SEAL AND SIGNATURE DATE: 03/24/2026
 PROJECT NO: 25_61 W 90TH ST
 DWG NO:

LPC-108.00

SHEET:
 12 OF 30

© 2026 MICHAEL K CHEN ARCHITECTURE, PLLC

LEGEND



CRACKS & DECOLORATION ON FACADE STUCCO SURFACES
MKCA RECORDS 40

CRACKS IN PAVEMENT
MKCA RECORDS 30



CRACKS & DISCOLORATION ON NEWELS
MKCA RECORDS 20

CRACKS IN STEPS AND THRESHOLD
MKCA RECORDS 10

03/24/2026 ISSUED FOR LPC SUBMISSION
01/02/2026 ISSUED FOR LPC SUBMISSION

Number	Date	Description	Issued to
CONTRACTOR			
TBD			
-			
-			

ARCHITECT
// MKCA //
MICHAEL K. CHEN ARCHITECTURE, PLLC
1239 BROADWAY, SUITE 600
NEW YORK, NY 10001
(212) 732-0060
eastcoast@mkca.com

PROJECT
90TH STREET AREAWAY
61 West 90th St, New York, NY 10024

**FRONT FACADE
CURRENT CONDITIONS**

SEAL AND SIGNATURE DATE: 03/24/2026
PROJECT NO: 25_61 W 90TH ST
DWG NO:

LPC-109.00

SHEET:
13 OF 30

© 2026 MICHAEL K CHEN ARCHITECTURE, PLLC

LEGEND



GARAGE LIGHTS AT TIME OF DESIGNATION



EXISTING AREAWAY LIGHT

(N) MERIDIAN 2" STEP LIGHTS, ROUND FACEPLATE, EXTRA DARK BRONZE LIVING PATINA, AT 3 (N) STEP LOCATIONS

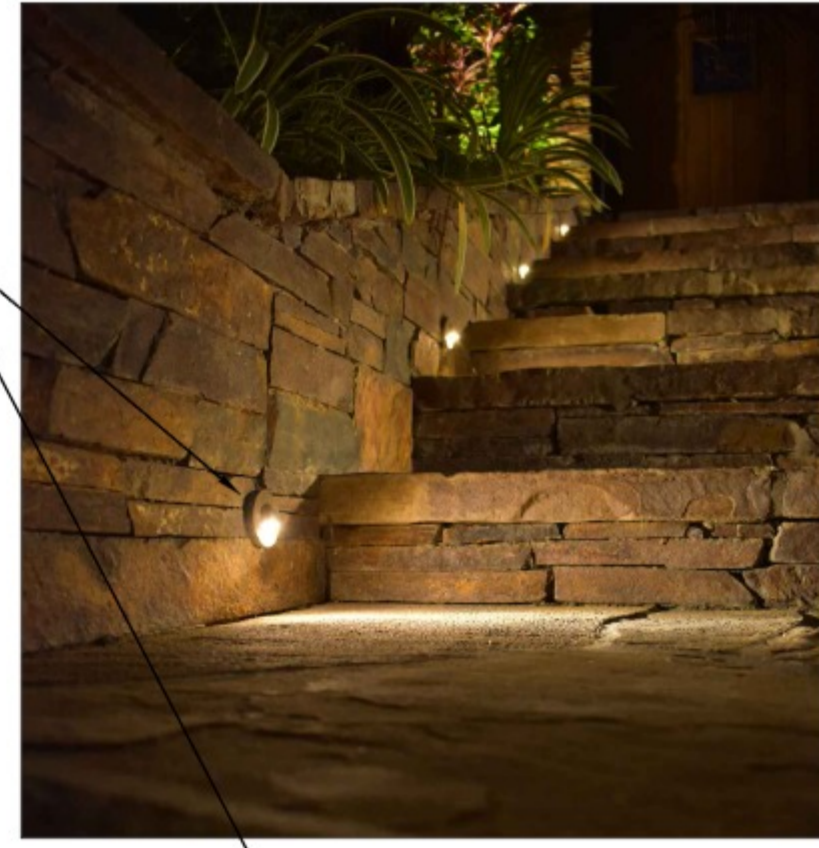

(N) SISTEMALUX ROUND ZIP COMFORT DOWNLIGHT, TO REPLACE (E) EXTERIOR AREAWAY DECORATIVE FIXTURE

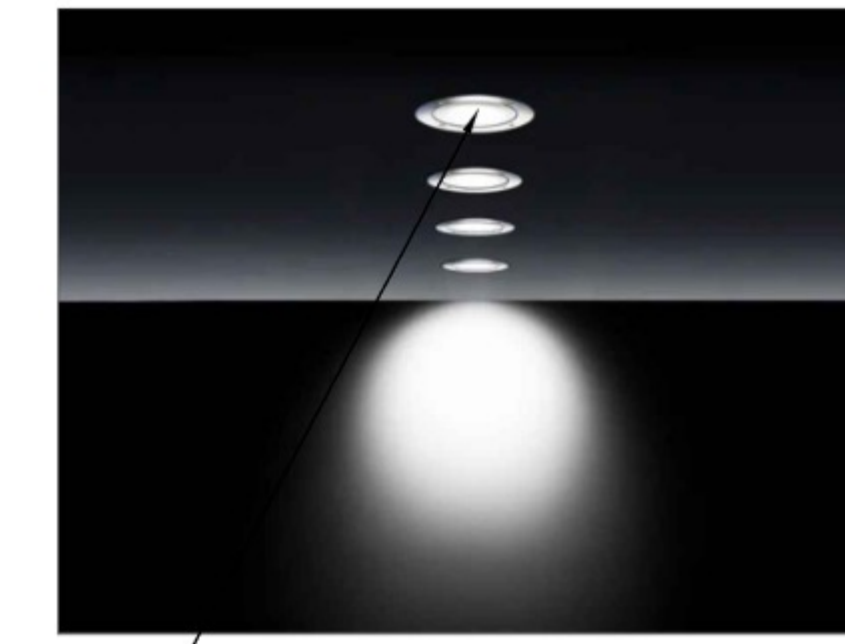

PROPOSED AREAWAY LIGHT FIXTURES 30

(N) URBAN ELECTRIC ARCADE EXTERIOR SCONCES, TO REPLACE 3 (E) EXTERIOR GARAGE LIGHT FIXTURES, BLACKENED COPPER FINISH

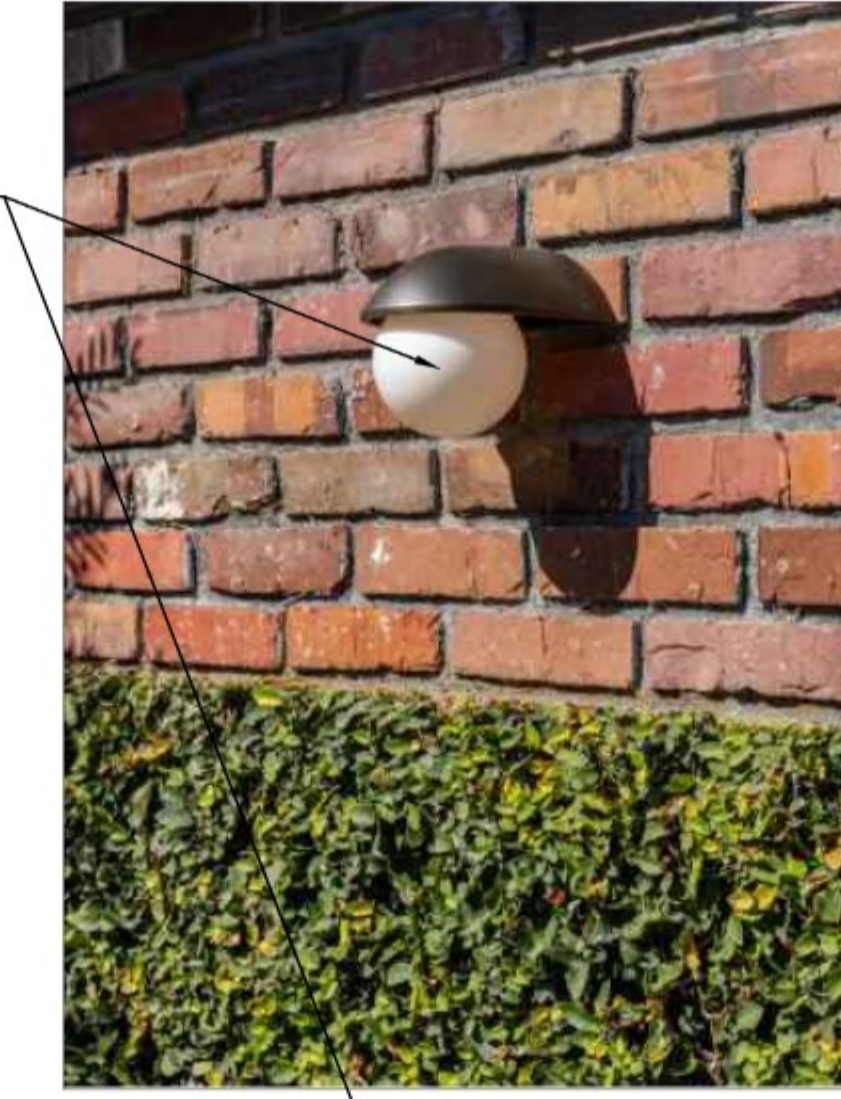

PROPOSED GARAGE LIGHT FIXTURES 20

(E) AREAWAY DECORATIVE LIGHT FIXTURE TO BE REPLACED WITH (N) RECESSED FIXTURE, SEE 30/LPC-111

(E) GARAGE LIGHTS TO BE REPLACED WITH (N) DECORATIVE LIGHT FIXTURES, SEE 20/LPC-111



EXISTING GARAGE LIGHTS



EXISTING LIGHT FIXTURES MKCA RECORDS 10

03/24/2026 ISSUED FOR LPC SUBMISSION

Number	Date	Description	Issued to
CONTRACTOR			
TBD			
-			
-			

CONTRACTOR
TBD

ARCHITECT
// MKCA //
MICHAEL K. CHEN ARCHITECTURE, PLLC
1239 BROADWAY, SUITE 600
NEW YORK, NY 10001
(212) 732-0060
eastcoast@mkca.com

PROJECT
90TH STREET AREAWAY
61 West 90th St, New York, NY 10024

FRONT FACADE
EXTERIOR LIGHTING

SEAL AND SIGNATURE _____ DATE: 03/24/2026
PROJECT NO: 25_61 W 90TH ST
DWG NO: _____

LPC-111.00

SHEET:
15 OF 30

© 2026 MICHAEL K CHEN ARCHITECTURE, PLLC

LEGEND

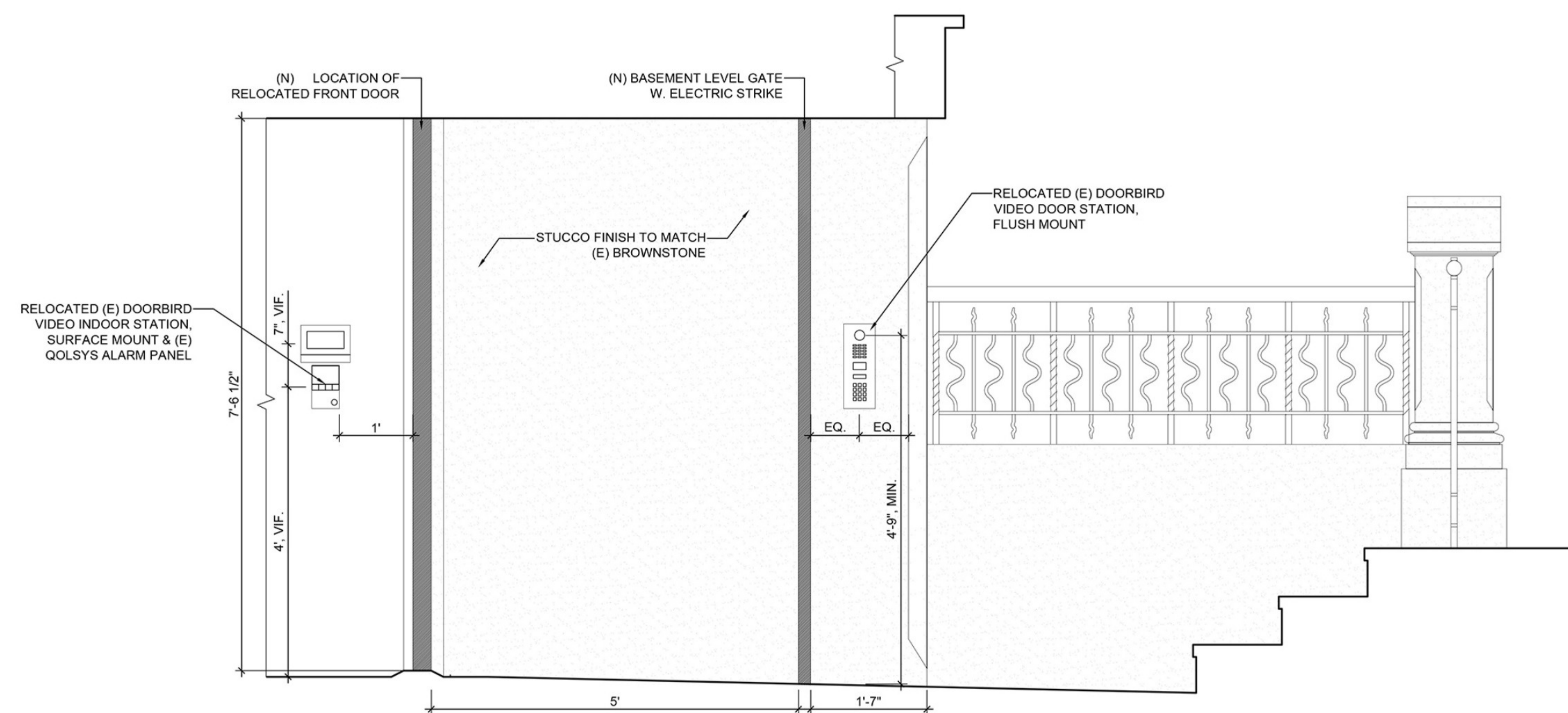

ENLARGED AREAWAY ELEVATION/SECTION - EAST
1/2"=1'-0" 20

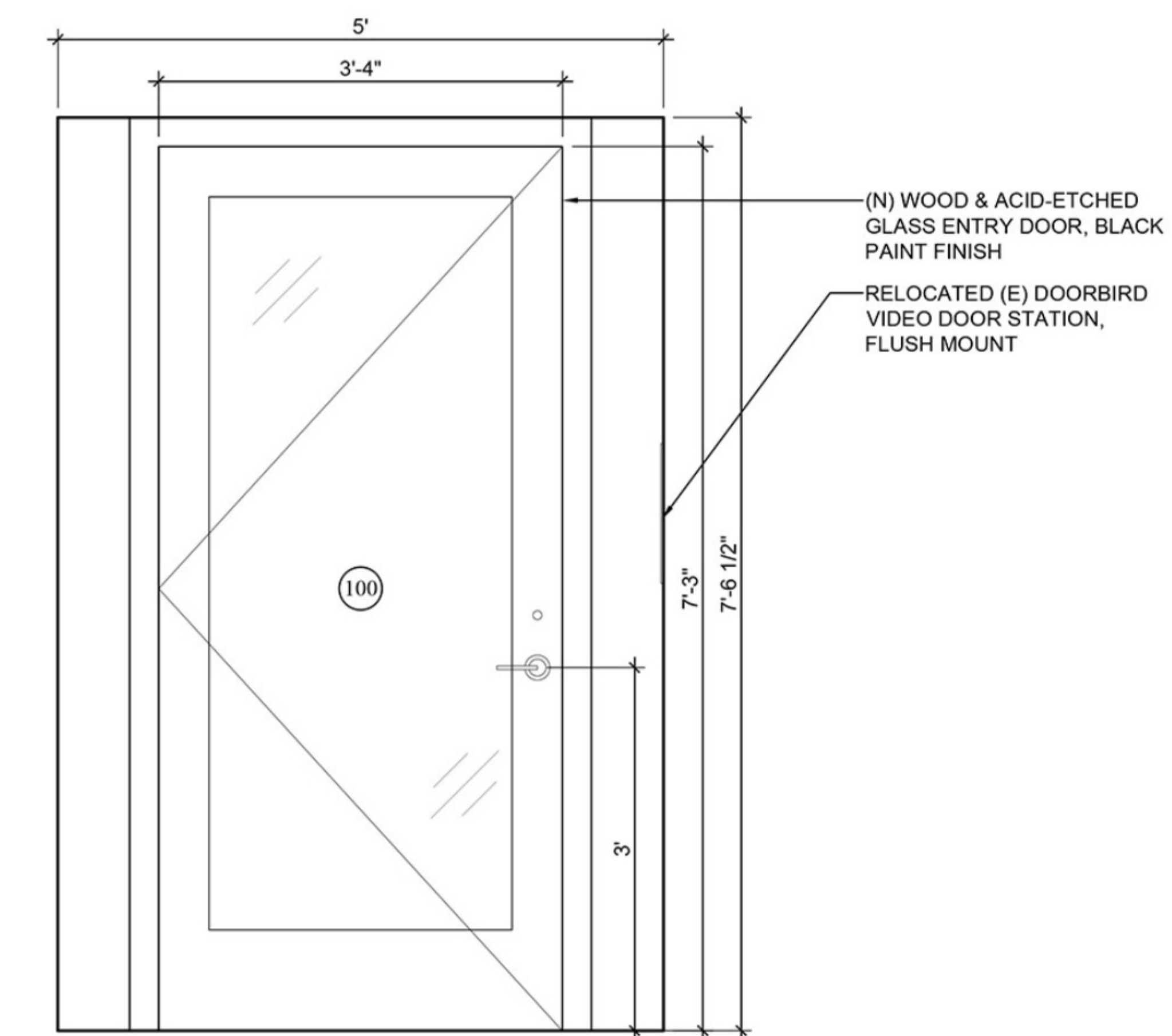

ENLARGED AREAWAY ELEVATION - ENTRY DOOR
1/2"=1'-0" 10

Number	Date	Description	Issued to
03/24/2026	03/24/2026	ISSUED FOR LPC SUBMISSION	
01/02/2026	01/02/2026	ISSUED FOR LPC SUBMISSION	

Number	Date	Description	Issued to
CONTRACTOR			
TBD			
-			
-			

ARCHITECT
// MKCA //
 MICHAEL K. CHEN ARCHITECTURE, PLLC
 1239 BROADWAY, SUITE 600
 NEW YORK, NY 10001
 (212) 732-0060
 eastcoast@mkca.com

PROJECT
90TH STREET AREAWAY
 61 West 90th St, New York, NY 10024

EXTERIOR VESTIBULE ELEVATIONS

SEAL AND SIGNATURE	DATE:	03/24/2026
	PROJECT NO.:	25_61 W 90TH ST
	DWG NO.:	

A220.00

SHEET:
23 OF 30

LEGEND

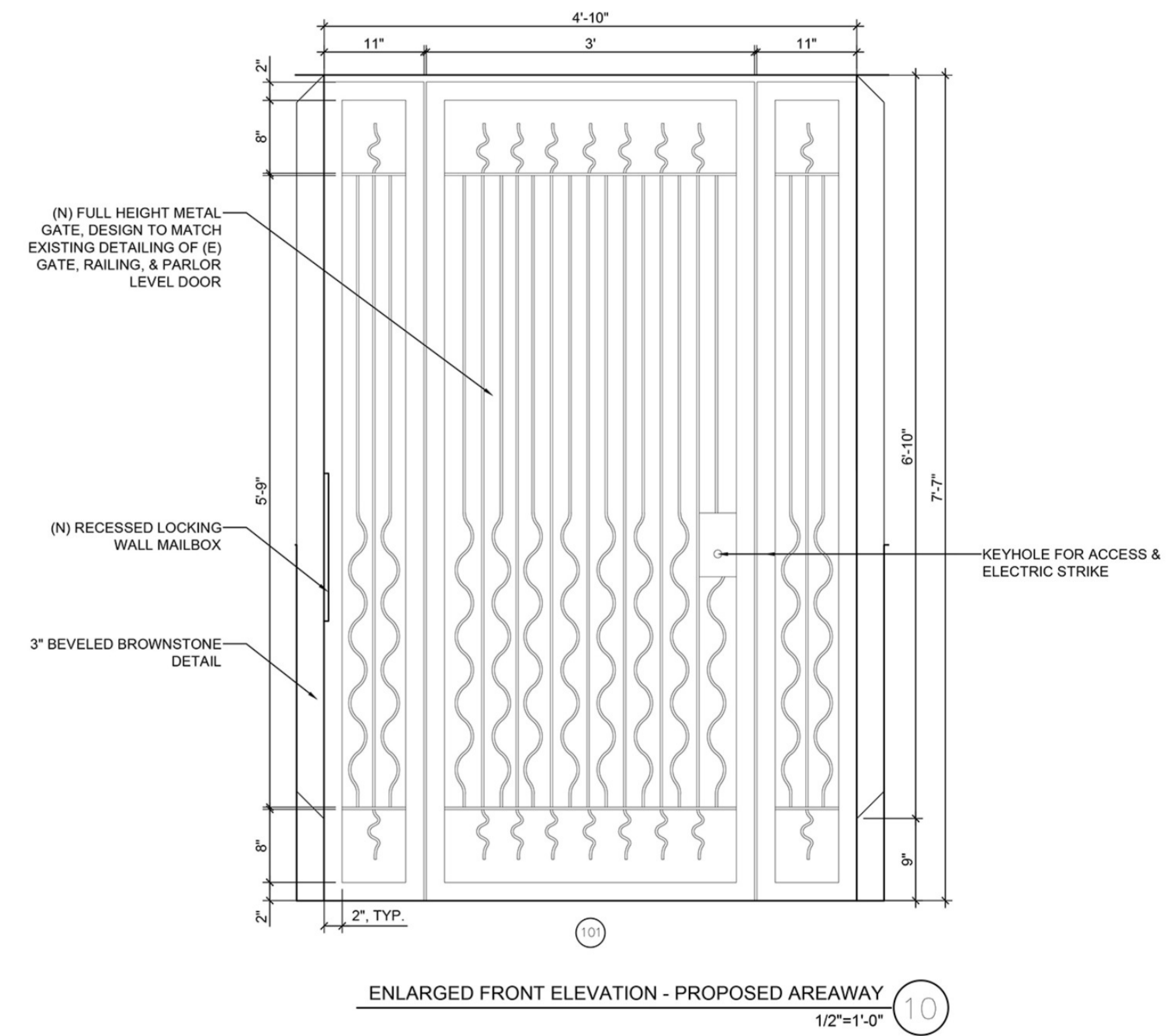

03/24/2026	ISSUED FOR LPC SUBMISSION
01/02/2026	ISSUED FOR LPC SUBMISSION

Number	Date	Description	Issued to
CONTRACTOR			
TBD			
-			
-			

ARCHITECT
// MKCA //
 MICHAEL K. CHEN ARCHITECTURE, PLLC
 1239 BROADWAY, SUITE 600
 NEW YORK, NY 10001
 (212) 732-0060
 eastcoast@mkca.com

PROJECT
90TH STREET AREAWAY
 61 West 90th St, New York, NY 10024

DOOR SCHEDULE & CASING DETAILS

SEAL AND SIGNATURE	DATE: 03/24/2026
	PROJECT NO. 25_61 W 90TH ST
	DWG NO:

A310.00

SHEET:
25 OF 30

LEGEND

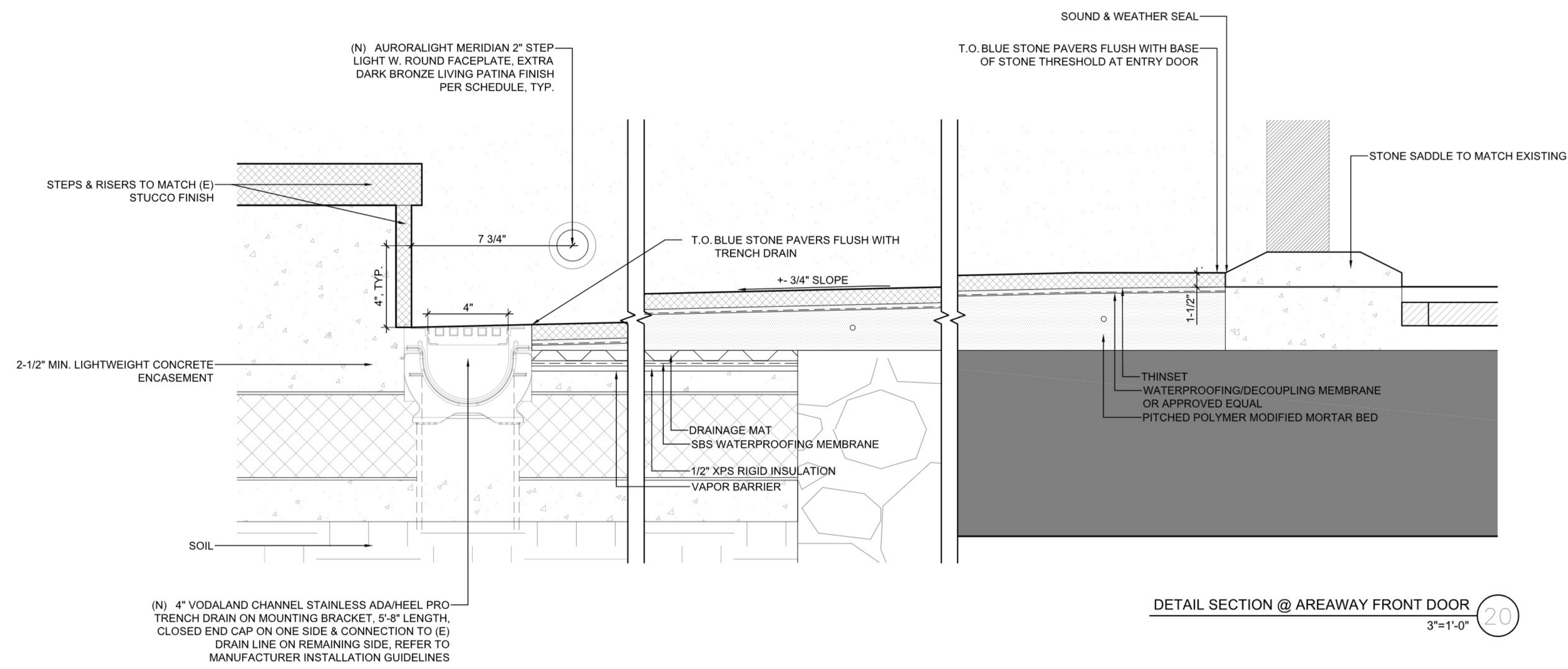

DETAIL SECTION @ AREAWAY FRONT DOOR
3"=1'-0" 20

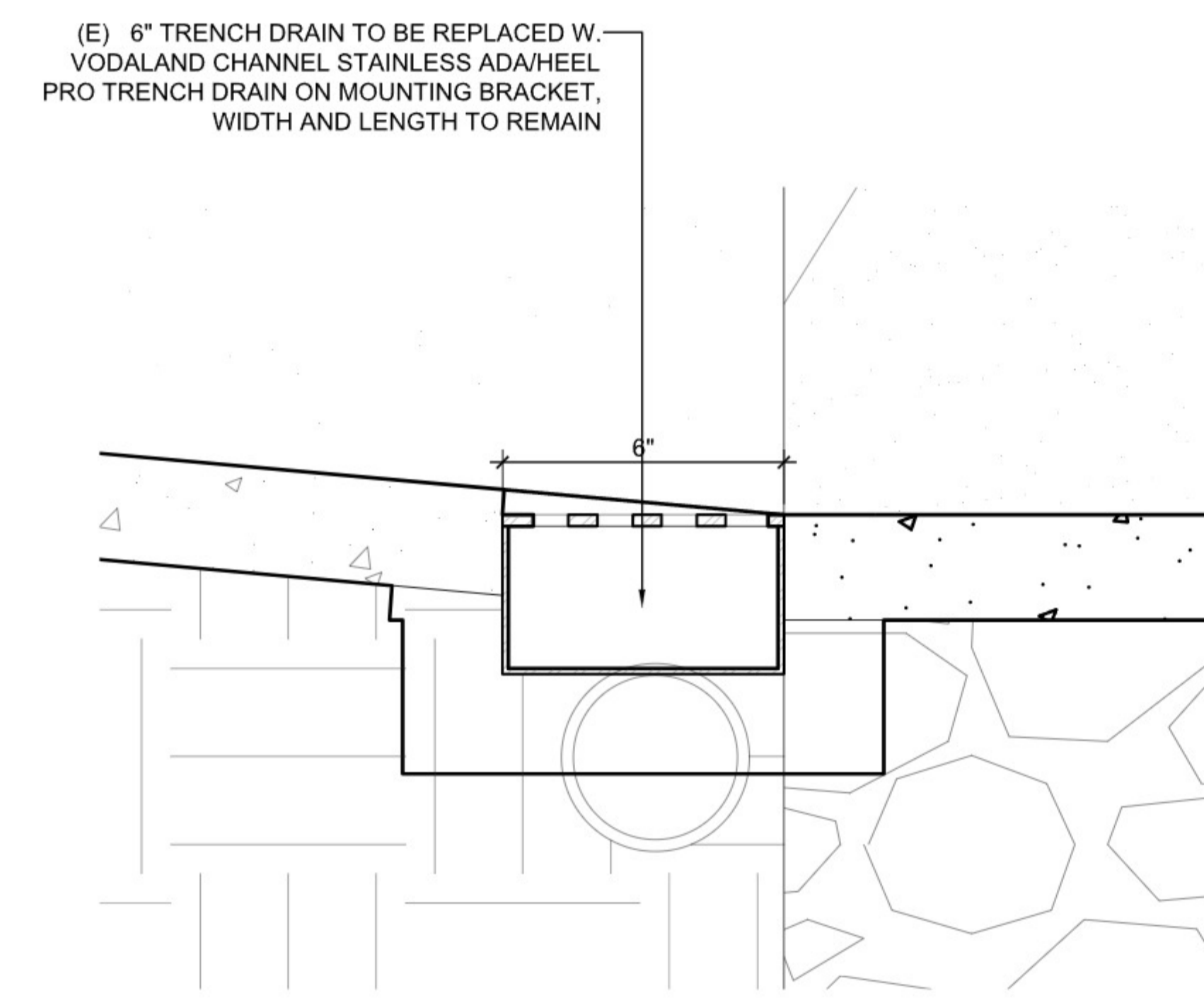

DETAIL SECTION @ GARAGE DOOR
3"=1'-0" 10

03/24/2026 ISSUED FOR LPC SUBMISSION
01/02/2026 ISSUED FOR LPC SUBMISSION

Number	Date	Description	Issued to
CONTRACTOR			
TBD			
-			
-			

ARCHITECT
// MKCA //
MICHAEL K. CHEN ARCHITECTURE, PLLC
1239 BROADWAY, SUITE 600
NEW YORK, NY 10001
(212) 732-0060
eastcoast@mkca.com

PROJECT
90TH STREET AREAWAY
61 West 90th St, New York, NY 10024

DRAINAGE DETAILS

SEAL AND SIGNATURE DATE: 03/24/2026
PROJECT NO: 25_61 W 90TH ST
DWG NO:

A700.00

SHEET:
28 OF 30

© 2026 MICHAEL K CHEN ARCHITECTURE, PLLC

LEGEND

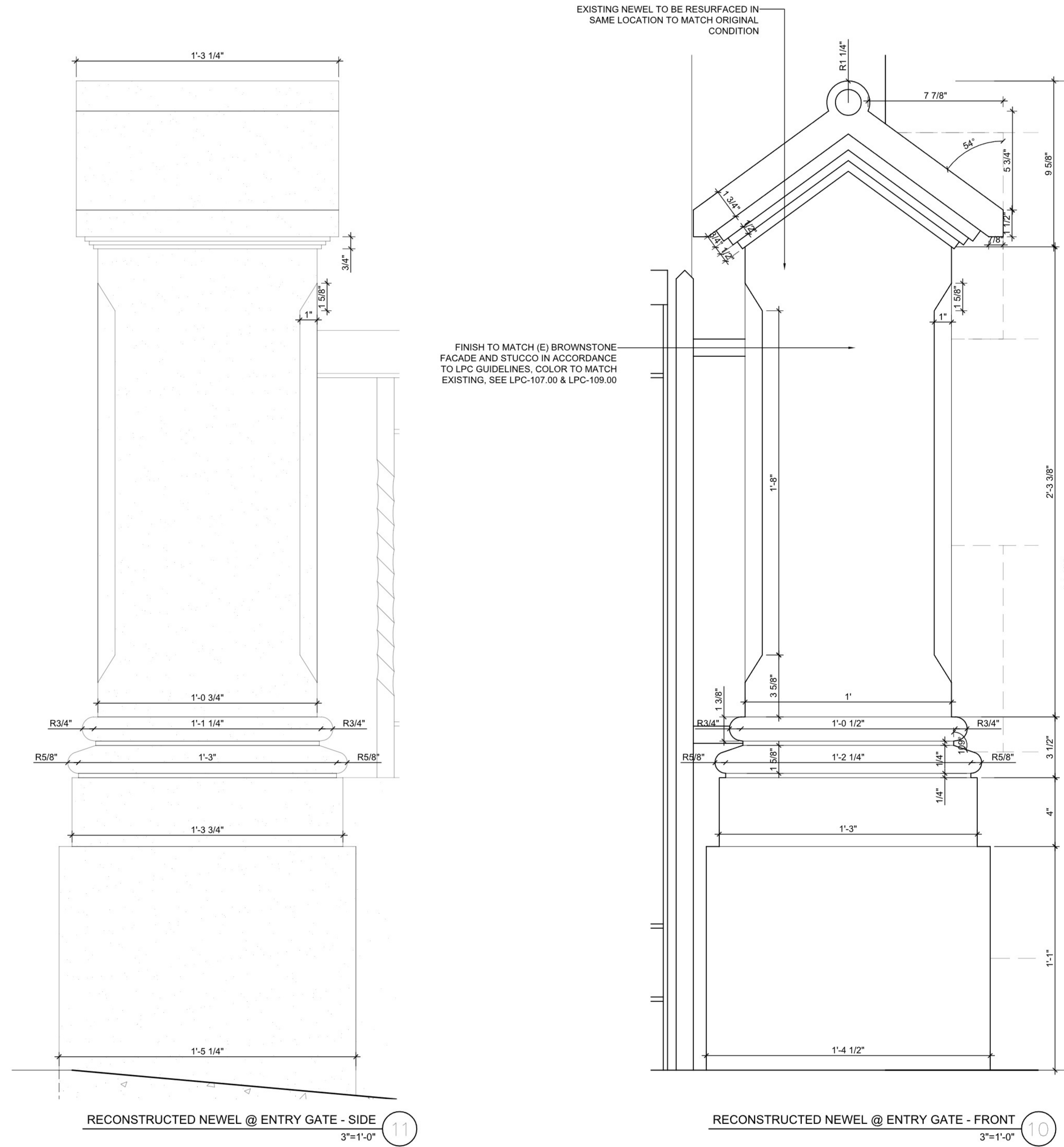

03/24/2026 ISSUED FOR LPC SUBMISSION
01/02/2026 ISSUED FOR LPC SUBMISSION

Number	Date	Description	Issued to

CONTRACTOR
TBD

ARCHITECT
// MKCA //
MICHAEL K. CHEN ARCHITECTURE, PLLC
1239 BROADWAY, SUITE 600
NEW YORK, NY 10001
(212) 732-0060
eastcoast@mkca.com

PROJECT
90TH STREET AREAWAY
61 West 90th St, New York, NY 10024

FRONT FACADE STONE & TRIM DETAILS

SEAL AND SIGNATURE DATE: 03/24/2026
PROJECT NO: 25_61 W 90TH ST
DWG NO:

A710.00

SHEET:
29 OF 30

LEGEND

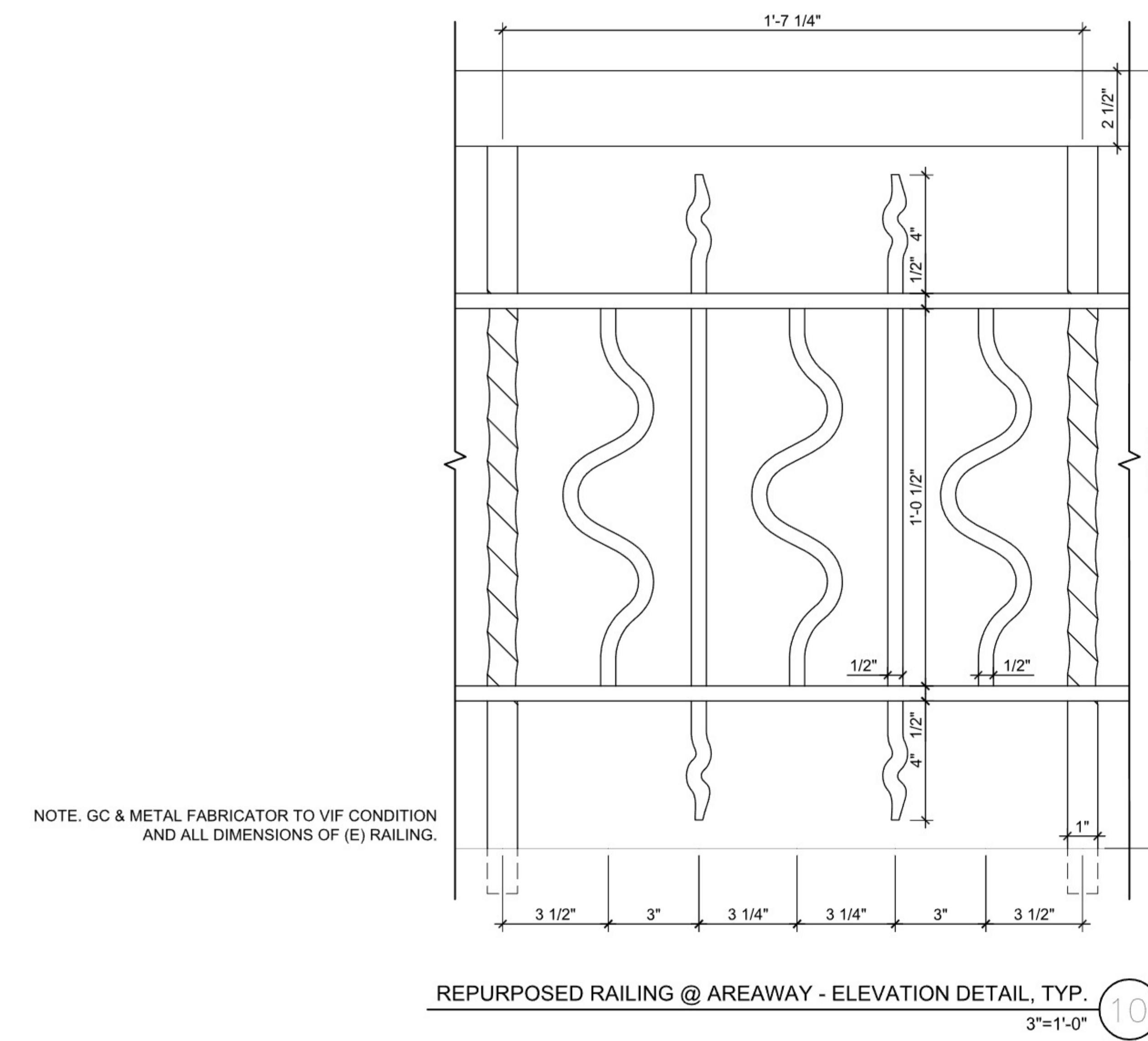
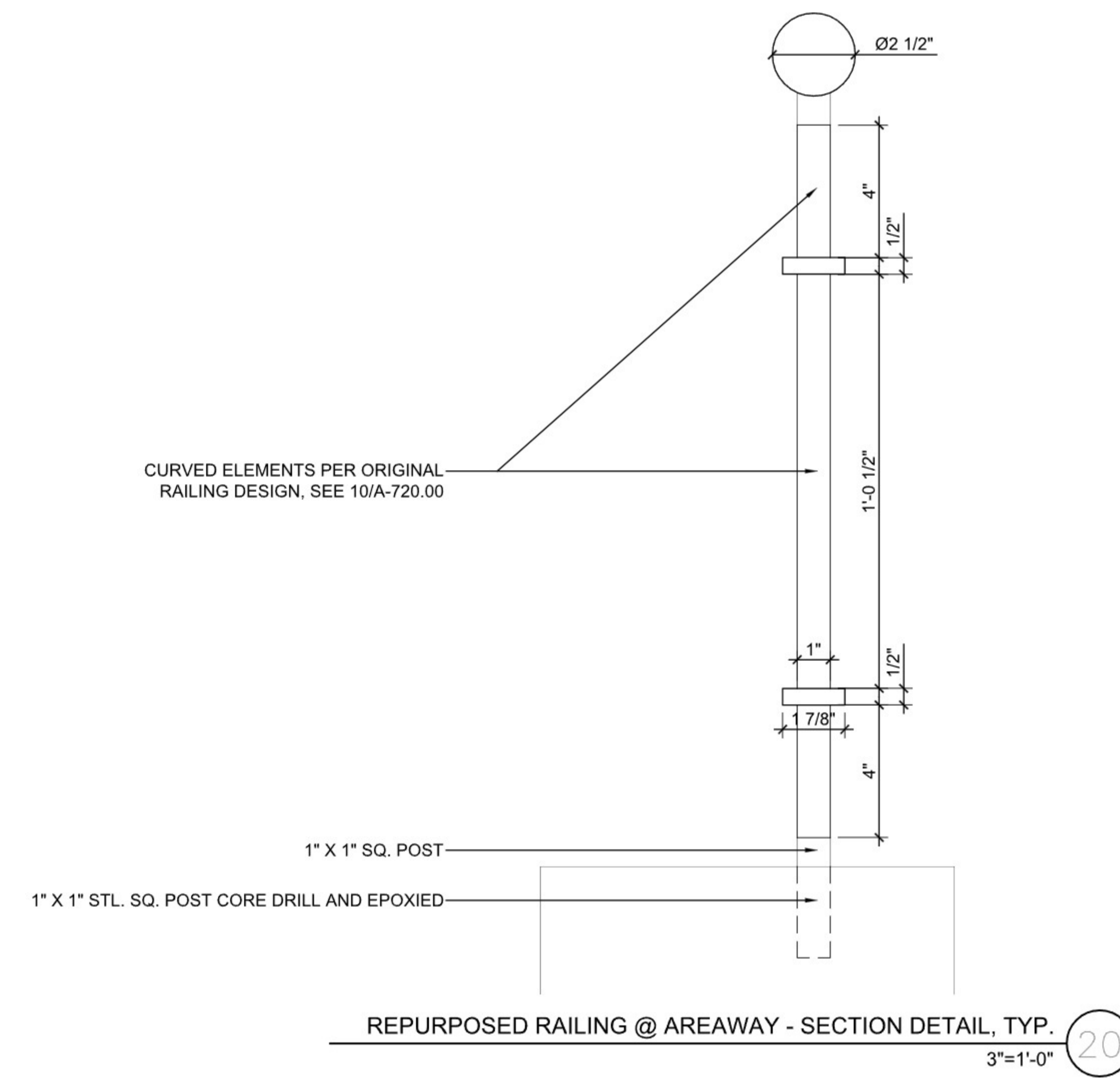

Number	Date	Description	Issued to
03/24/2026	01/02/2026	ISSUED FOR LPC SUBMISSION	ISSUED FOR LPC SUBMISSION

CONTRACTOR
TBD

ARCHITECT
// MKCA //
MICHAEL K. CHEN ARCHITECTURE, PLLC
1239 BROADWAY, SUITE 600
NEW YORK, NY 10001
(212) 732-0060
eastcoast@mkca.com

PROJECT
90TH STREET AREAWAY
61 West 90th St, New York, NY 10024

**FRONT FACADE
METALWORK DETAILS**

SEAL AND SIGNATURE DATE: 03/24/2026
PROJECT NO: 25_61 W 90TH ST
DWG NO:

A720.00

SHEET:
30 OF 30

© 2026 MICHAEL K CHEN ARCHITECTURE, PLLC

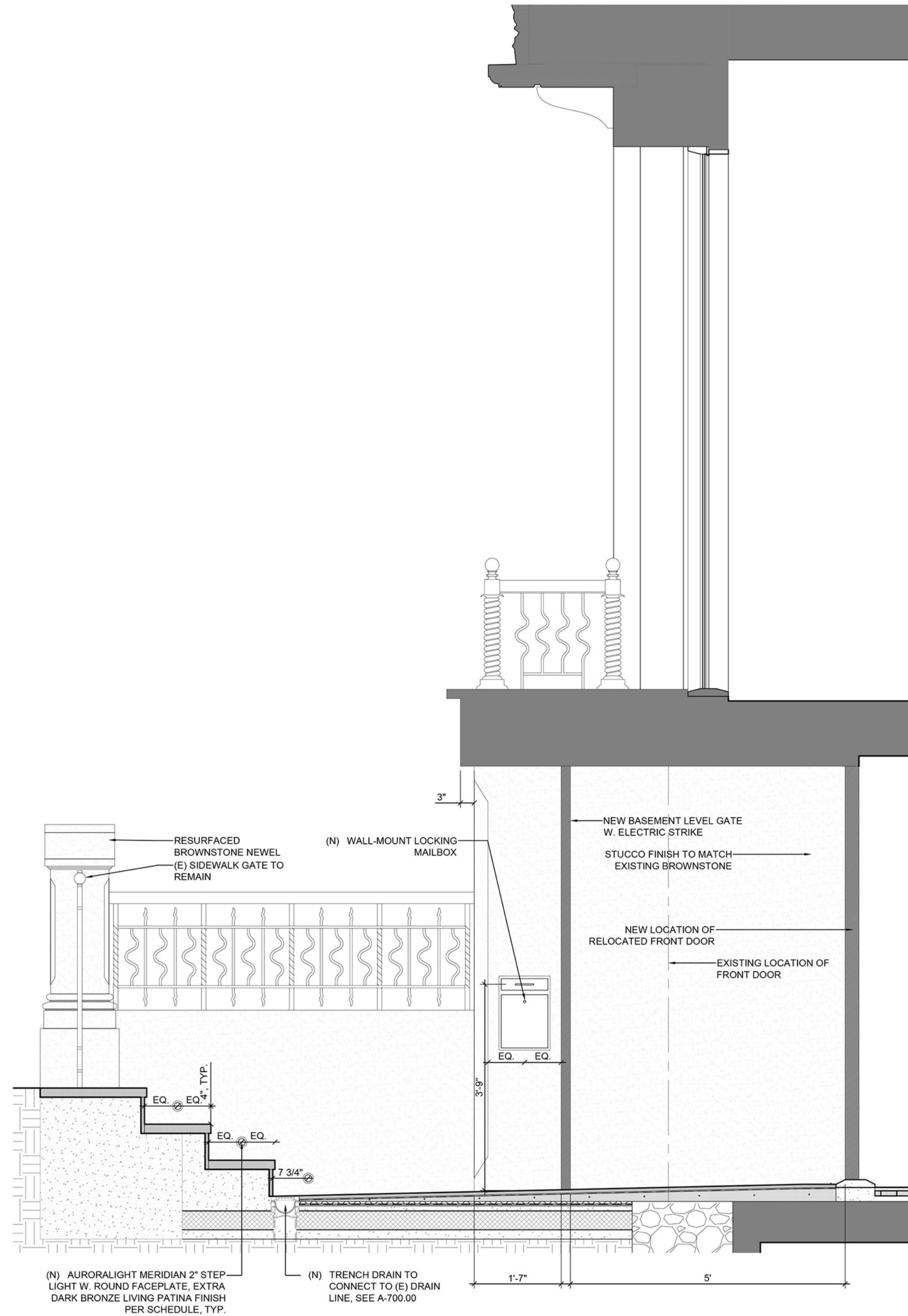

PROPOSED MAILBOX

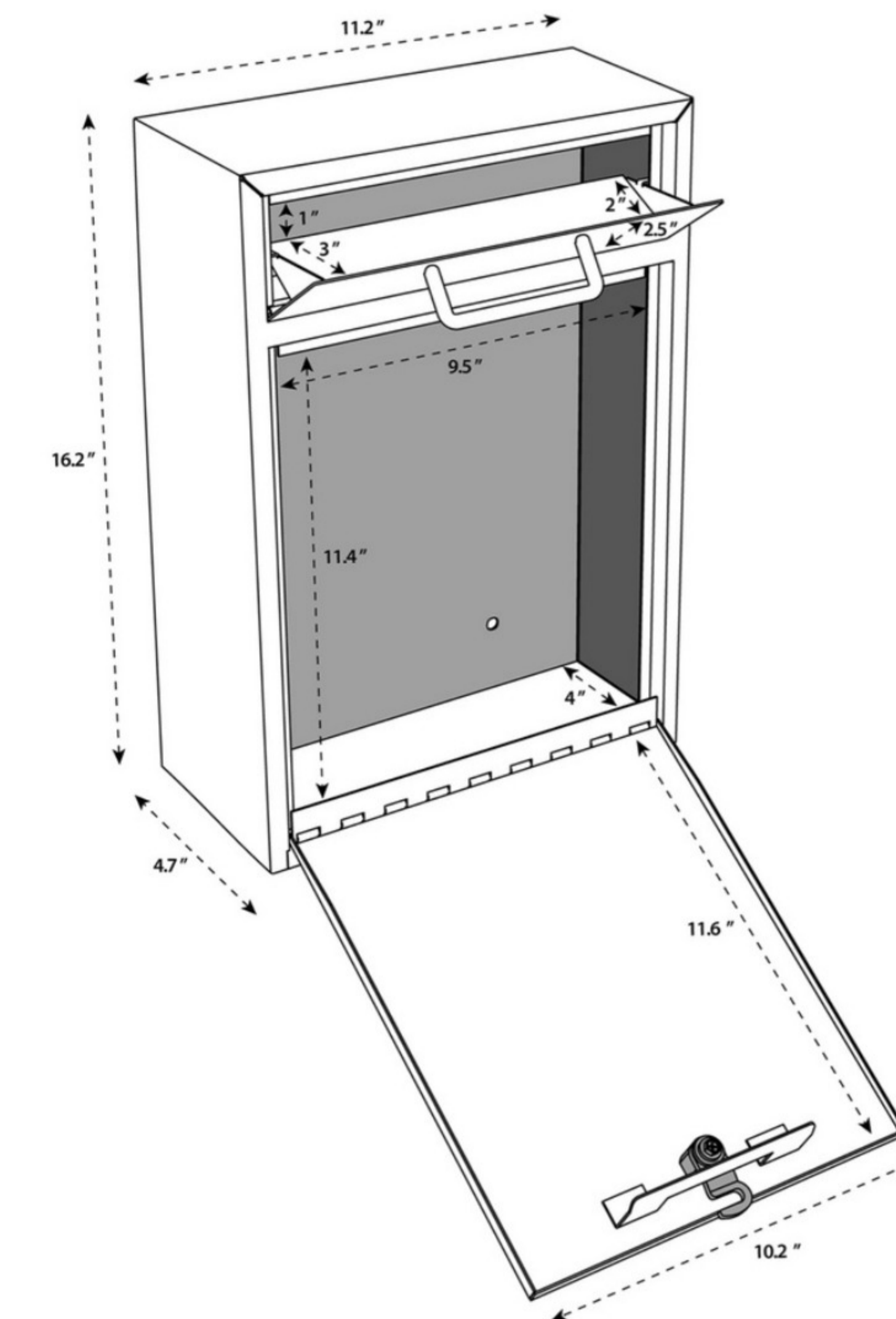

May 5, 2026
Public Meeting

The current proposal is:

Preservation Department – Item 2, LPC-26-06719

**61 West 90th Street – Upper West Side/Central Park West
Historic District
Borough of Manhattan**

To testify virtually, please join Zoom

Webinar ID: 161 198 1457

Passcode: 180173

By Phone: 646-828-7666 (NY)

833-435-1820 (Toll-free)

833-568-8864 (Toll-free)

Note: If you want to testify virtually on an item, join the Zoom webinar at the agenda's "Be Here by" time (about an hour in advance). When the Chair indicates it's time to testify, "raise your hand" via the Zoom app if you want to speak (*9 on the phone). Those who signed up in advance will be called first.