

The current proposal is:

**Preservation Department – Item 3, LPC-26-06268**

**385 Greenwich Street – Tribeca West Historic District**  
**Borough of Manhattan**

**Note: this is a Public Meeting item. No public testimony will be received today as the hearing on this item is closed.**

DXA studio  
385 GREENWICH  
APRIL 21, 2026

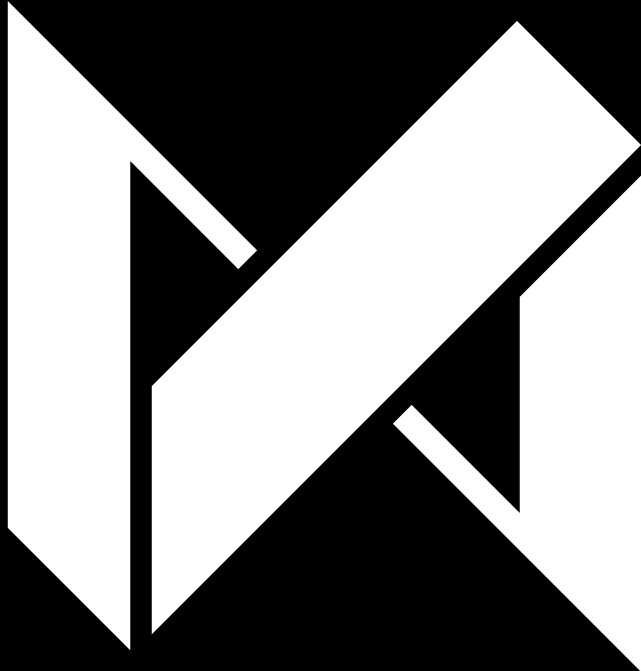



2025

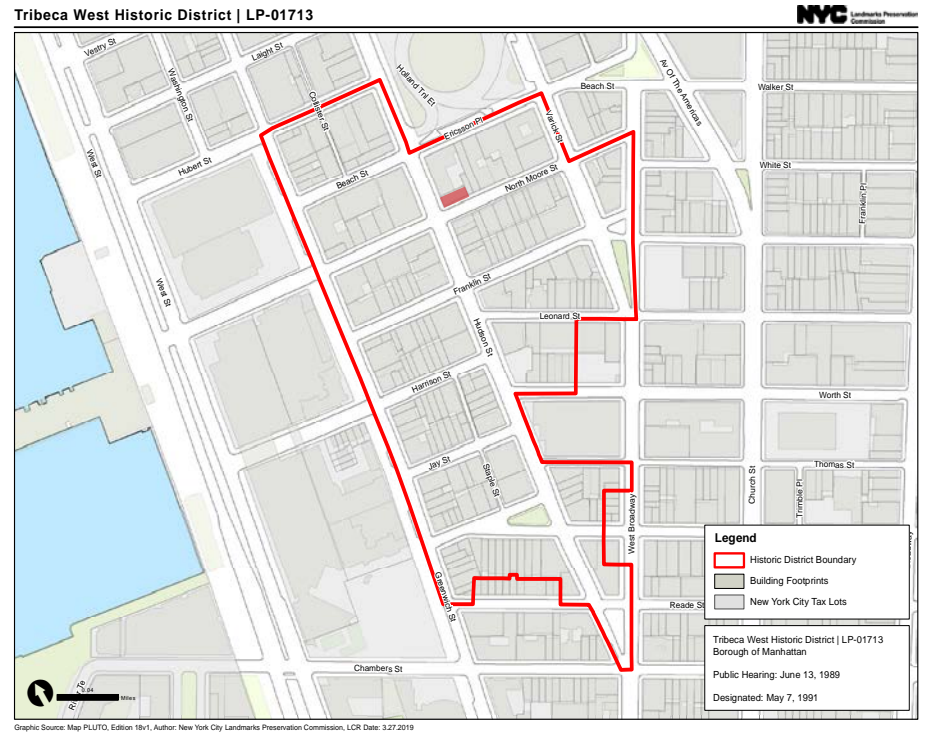

385 Greenwich



**DXA studio**

894 6th Avenue  
 5th Floor  
 NYC 10001  
 T 212 874 0567

dxastudio.com

**PROJECT NUMBER** 25.59  
**DATE** April 21, 2026

**01**

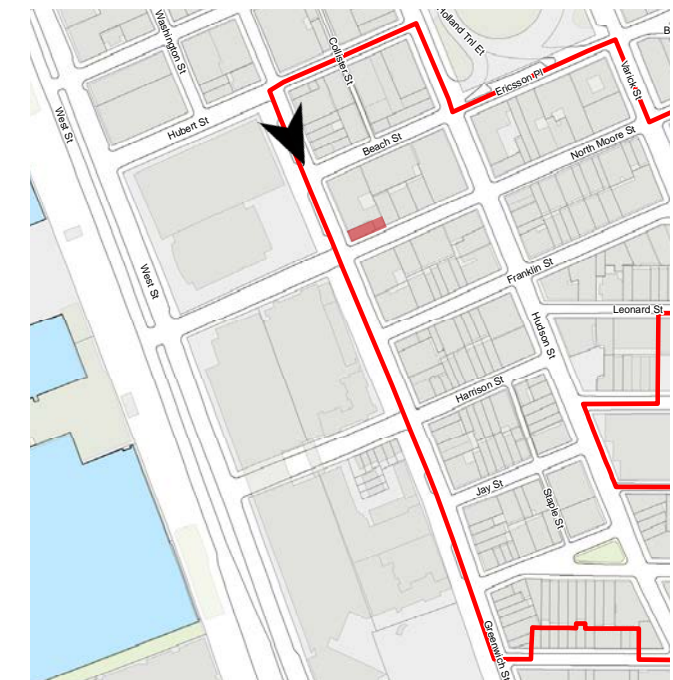

View South on Greenwich Street, 2025

385 Greenwich



**DXA studio**

894 6th Avenue  
5th Floor  
NYC 10001  
T 212 874 0567

dxastudio.com

**PROJECT NUMBER** 25.59  
**DATE** April 21, 2026

**02**



View West on North Moore Street, 2025

385 Greenwich



**DXA studio**

894 6th Avenue  
5th Floor  
NYC 10001  
T 212 874 0567

dxastudio.com

**PROJECT NUMBER** 25.59  
**DATE** April 21, 2026

**03**



2025



2025

385 Greenwich — EXISTING CONDITIONS



**DXA studio**

894 6th Avenue  
5th Floor  
NYC 10001  
T 212 874 0567

dxastudio.com

PROJECT NUMBER 25.59  
DATE April 21, 2026



2025



2025

385 Greenwich — **EXISTING CONDITIONS**



**DXA studio**

dxastudio.com

894 6th Avenue  
5th Floor  
NYC 10001  
T 212 874 0567

**PROJECT NUMBER** 25.59  
**DATE** April 21, 2026

**05**



2025



2025

385 Greenwich — EXISTING CONDITIONS



**DXA studio**

894 6th Avenue  
5th Floor  
NYC 10001  
T 212 874 0567

dxastudio.com

**PROJECT NUMBER** 25.59  
**DATE** April 21, 2026

**06**



2025



2025

385 Greenwich — EXISTING CONDITIONS



**DXA studio**

dxastudio.com

894 6th Avenue  
5th Floor  
NYC 10001  
T 212 874 0567

PROJECT NUMBER 25.59  
DATE April 21, 2026

**07**

St. John's Park  
(1800s, Tribeca Citizen)



St. John's Freight Terminal (1920s)

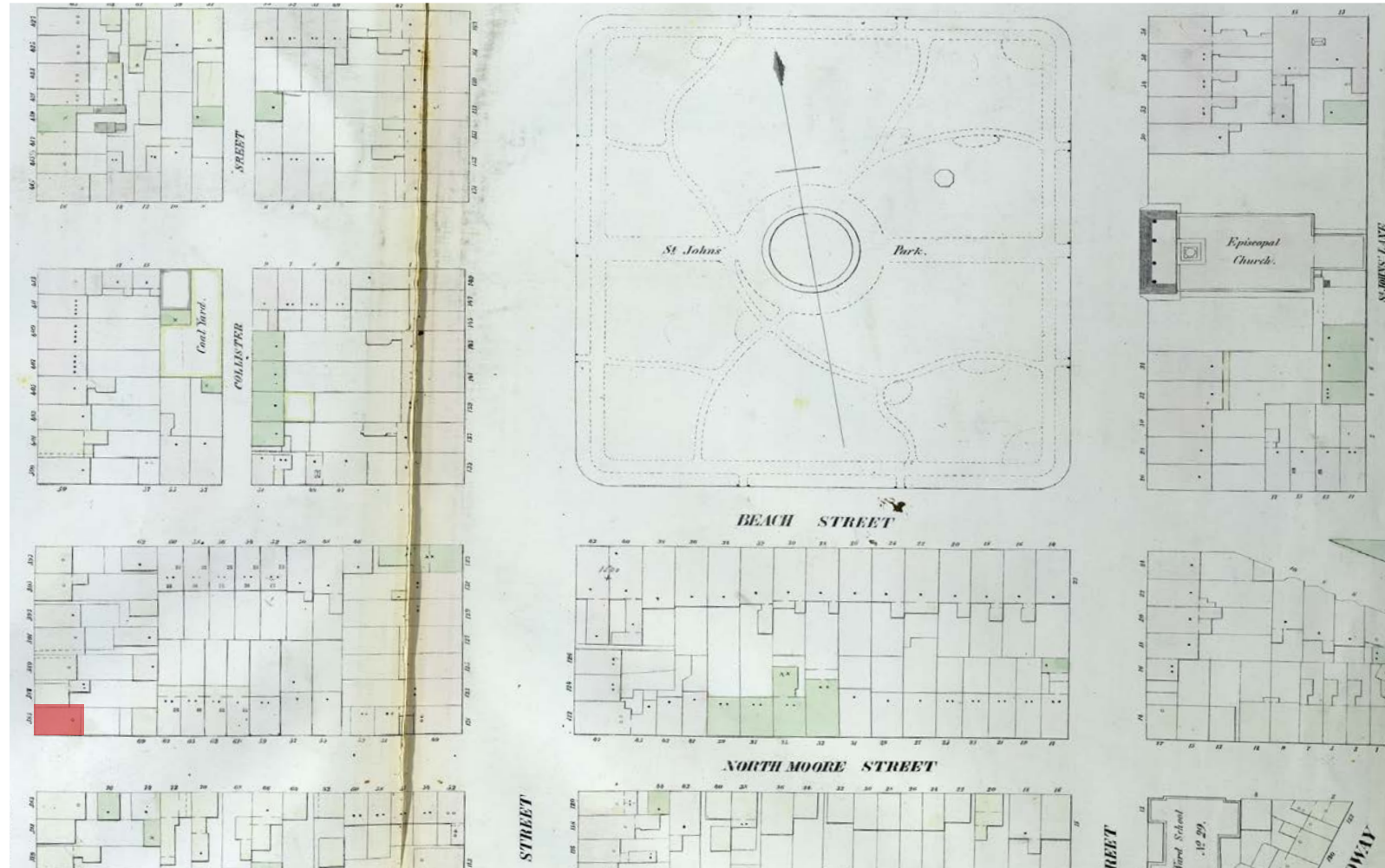

1853 (Perris)

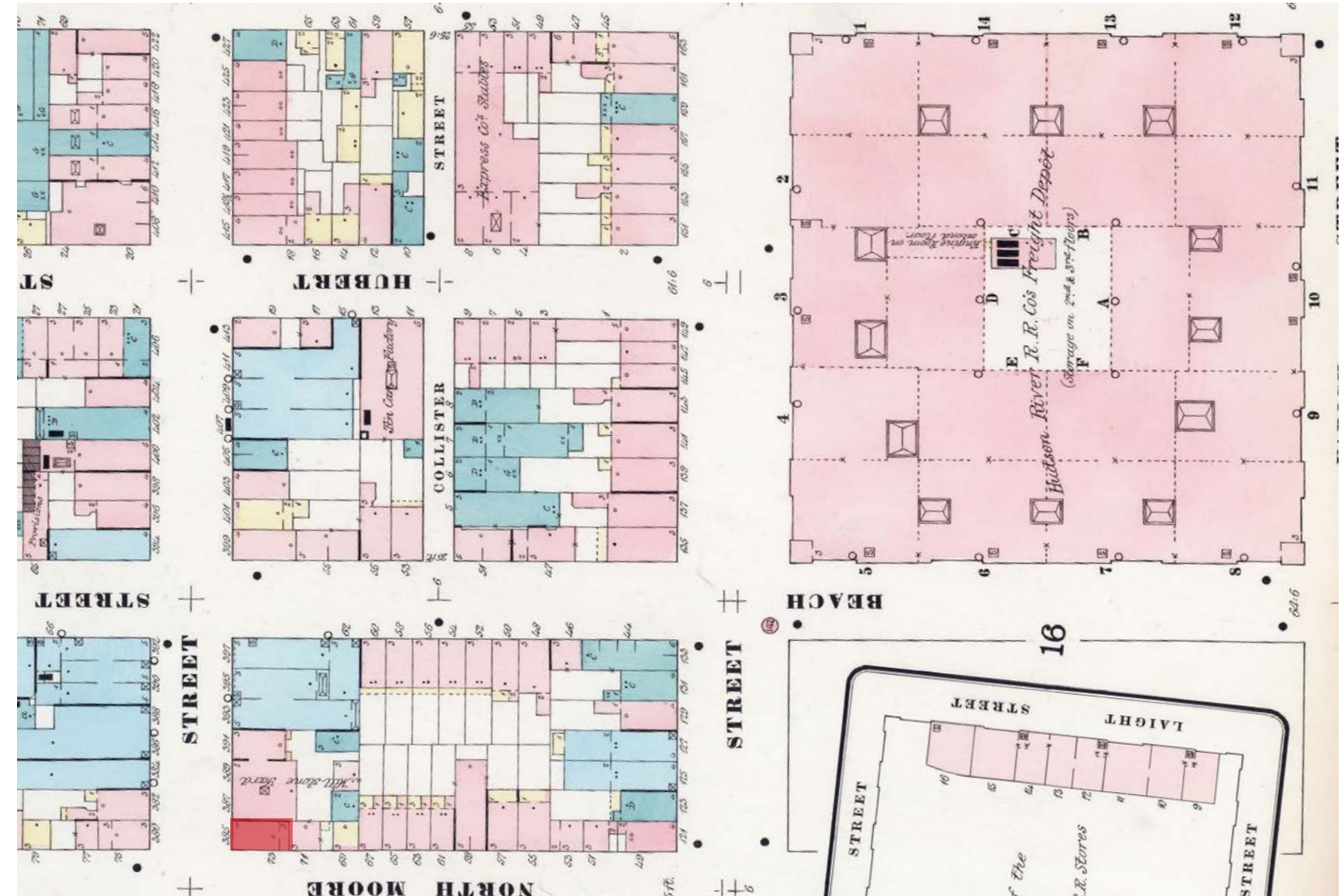

1884 (Sanborn)

385 Greenwich — HISTORIC CONTEXT



DXA studio

894 6th Avenue  
5th Floor  
NYC 10001  
T 212 874 0567

dxastudio.com

PROJECT NUMBER 25.59  
DATE April 21, 2026

08

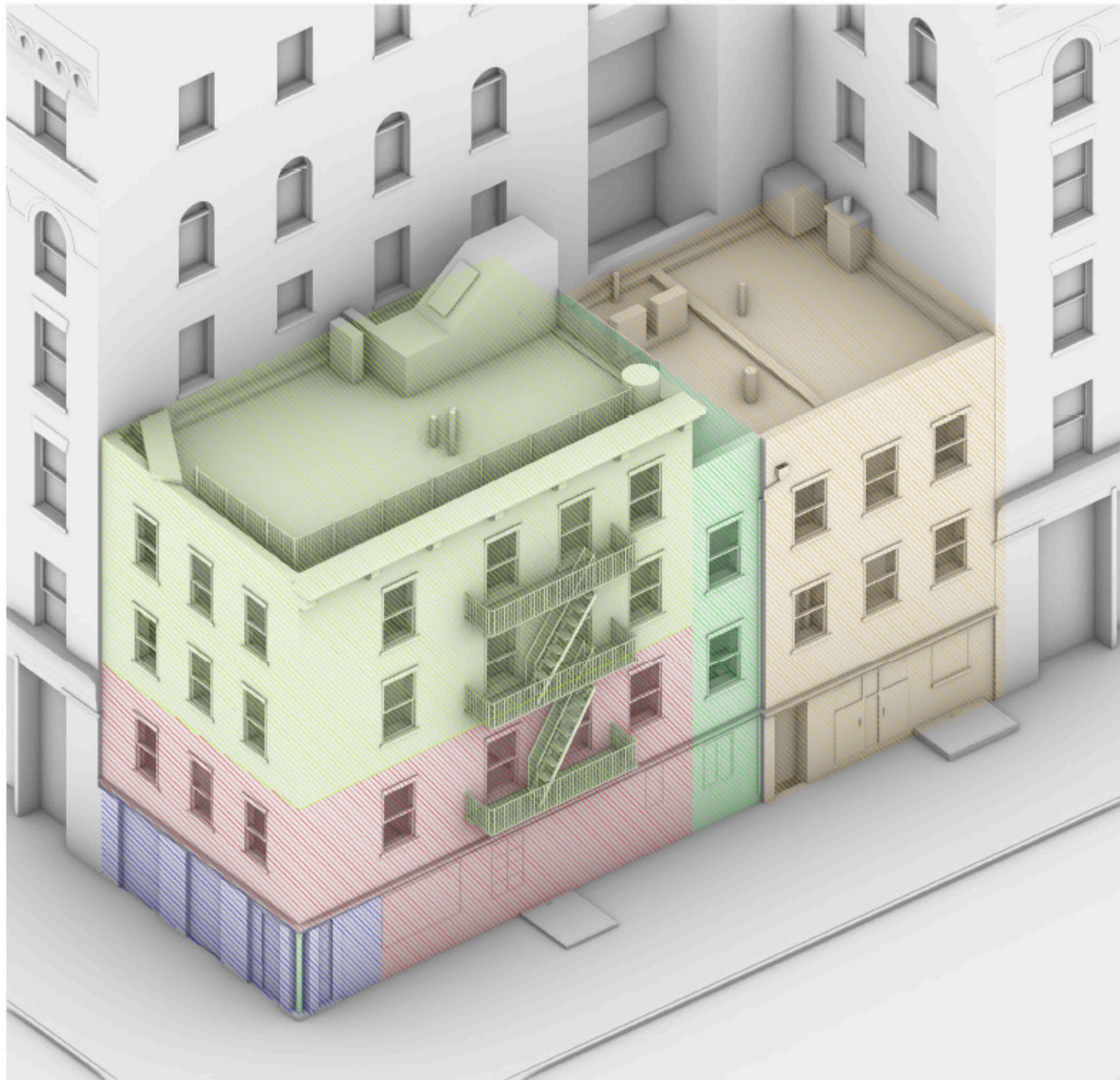

1. 1805 Original Building built. 385 G
  - a. 2 story building on the corner
2. 1815, 71 N Moore built
3. 1874, 3rd & 4th floor added to 385 Greenwich
  - a. Tenement
  - b. Bracketed cornice is added
  - c. Fire escape added
4. 1898, Storefronts replaced,
  - a. Projecting show windows placed
  - b. Corner entrance added
  - c. Extension added between two buildings
5. prior to 1940, storefront altered
6. 1949, Scored Stucco is added.
  - a. 71 N moore garage door is added.
7. prior to 1991, storefront altered
8. prior to 2016, storefront altered,
  - a. Greenwich fire escape removed
9. 2016, Storefront altered

-  2016
-  1898
-  1874
-  1815
-  1805



**DXA studio**

894 6th Avenue  
5th Floor  
NYC 10001  
T 212 874 0567

dxastudio.com

PROJECT NUMBER 25.59  
DATE April 21, 2026



50 Hudson  
Approved September 12, 2017



56 N Moore  
Approved August 4, 2020



62 Beach  
Approved 1999



**DXA studio**

dxastudio.com

894 6th Avenue  
5th Floor  
NYC 10001  
T 212 874 0567

385 Greenwich — **NEIGHBORHOOD CONTEXT**

**PROJECT NUMBER** 25.59  
**DATE** April 21, 2026

**10**

# DESIGN REVISIONS



### Commissioners' Comments - March 24, 2026 Public Hearing

- General acceptance of the appropriateness of a visible, designed rooftop addition
- Proportional relationship between the rooftop and the storefront should be studied
- Cornice at roof should be reduced in size
- Projection of storefront cornice and detailing should be revised

385 Greenwich — **PREVIOUSLY PROPOSED DESIGN**



**DXA studio**

dxastudio.com

894 6th Avenue  
5th Floor  
NYC 10001  
T 212 874 0567

PROJECT NUMBER 25.59  
DATE April 21, 2026

# 12

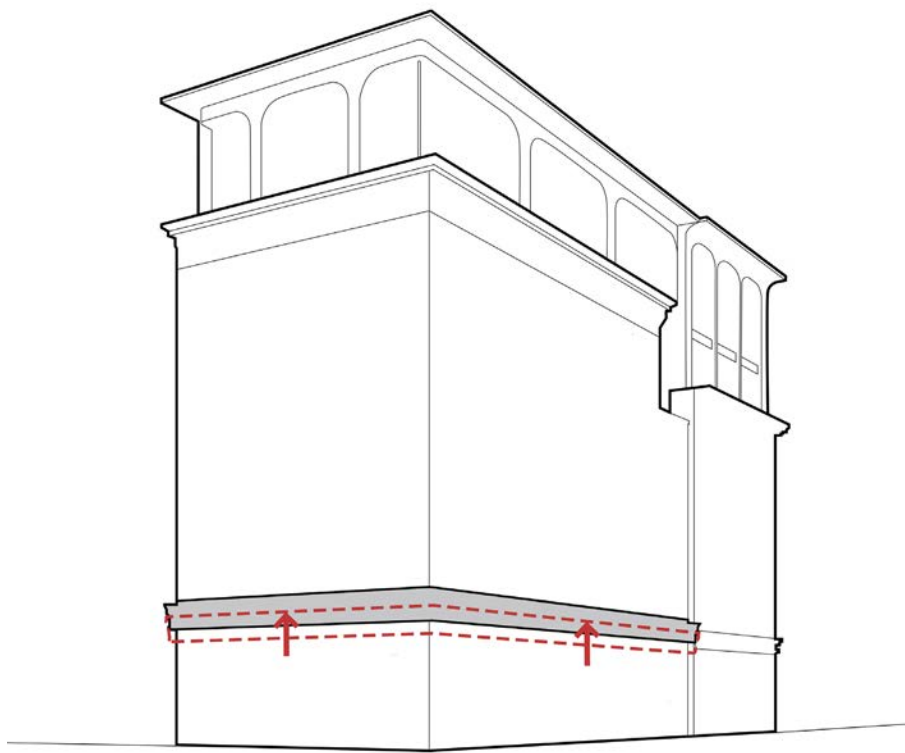

RELATIONSHIP OF STOREFRONT + ADDITION

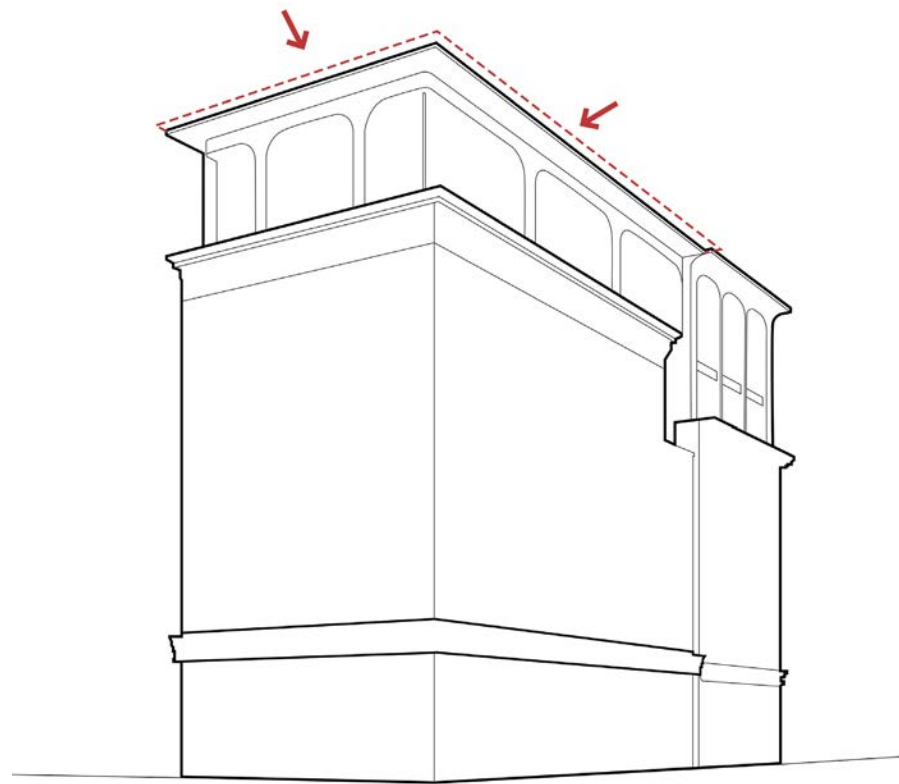

REDUCE PROJECTION OF CORNICE AT ADDITION

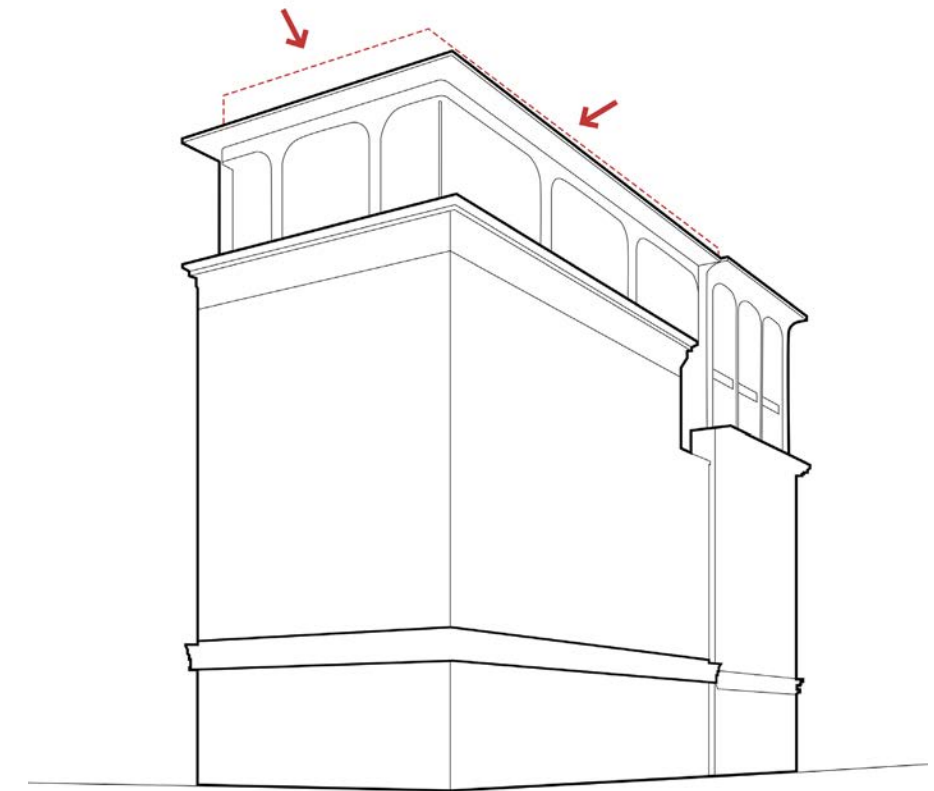

SET BACK ROOF RAILING

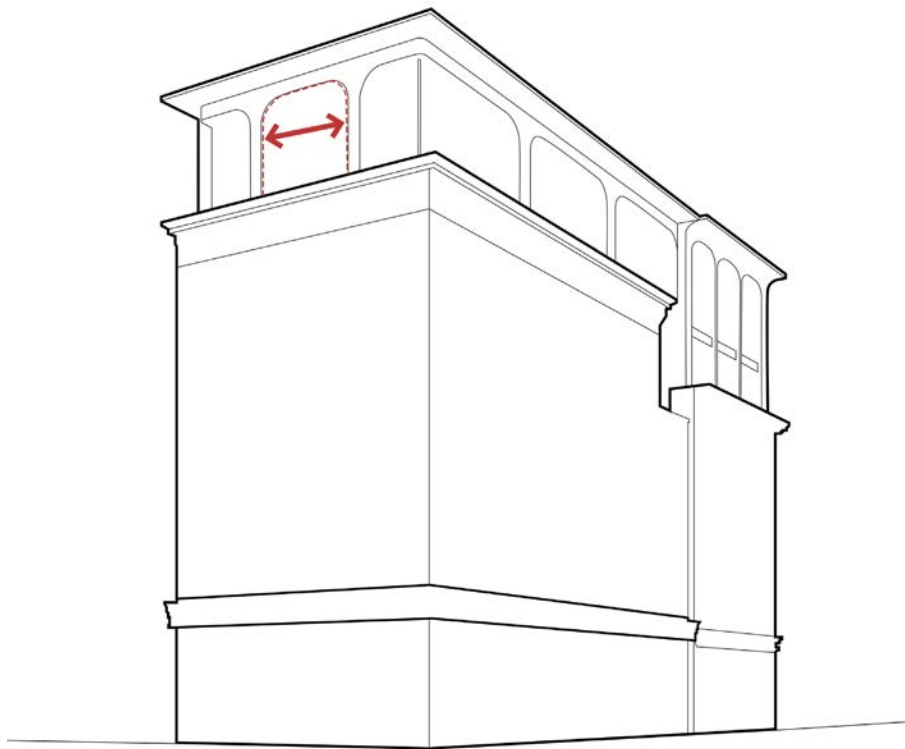

EXPAND CENTER BAY TO REDUCE VERTICALITY OF WEST ELEVATION

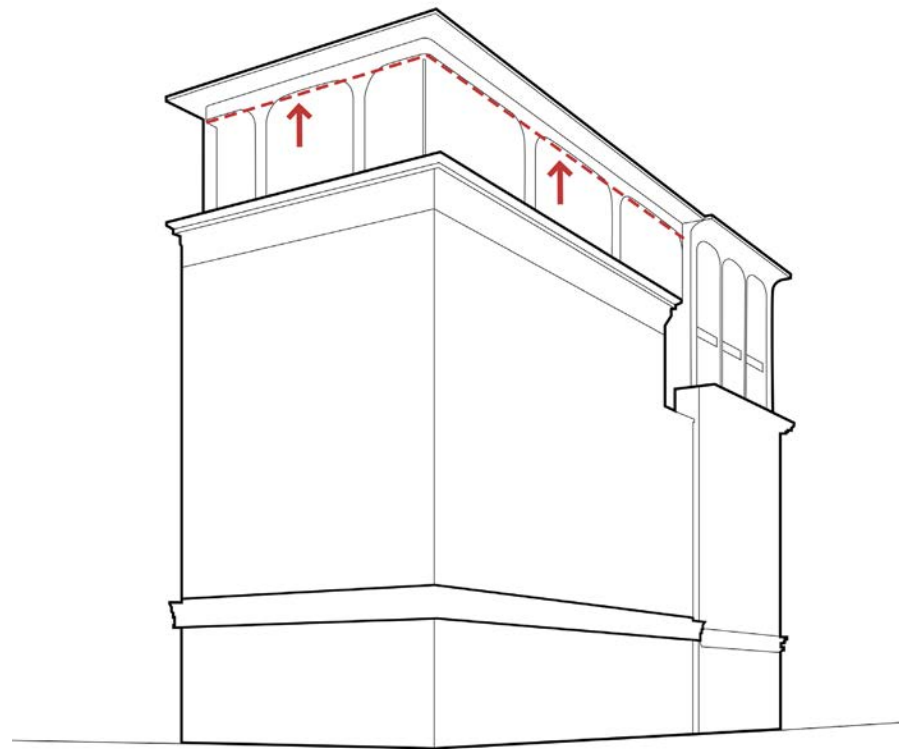

REDUCE SPANDREL DEPTH TO BALANCE WITH REDUCED CORNICE ABOVE

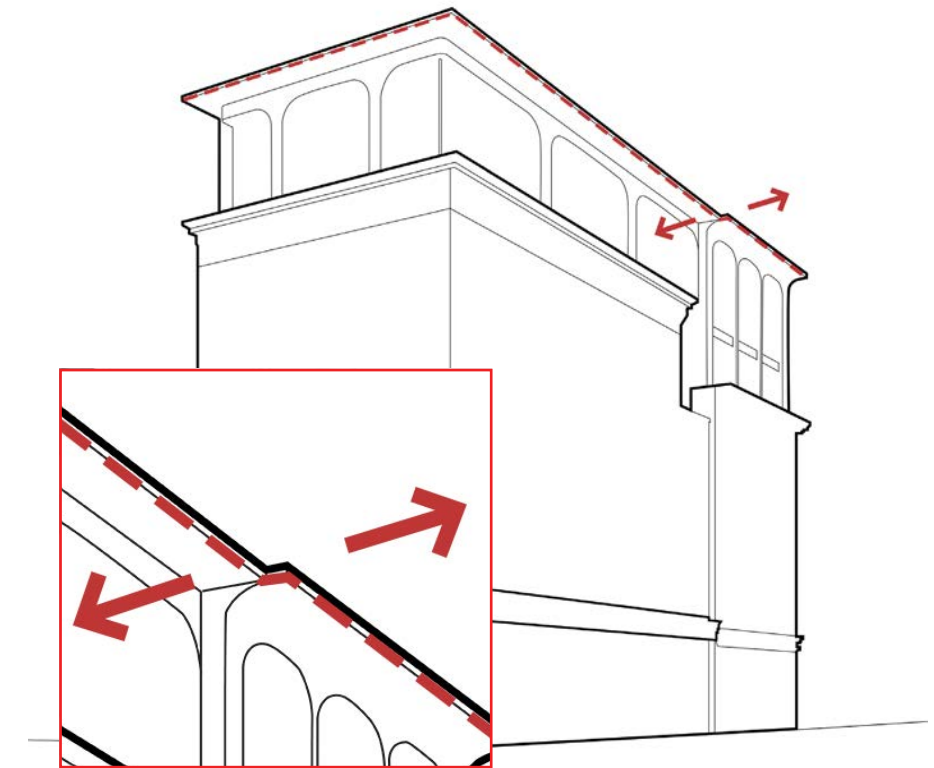

BREAK CORNICE BETWEEN 385 GREENWICH & 71 N MOORE

Updated Proposed Design



**DXA studio** 894 6th Avenue  
5th Floor  
NYC 10001  
dxastudio.com T 212 874 0567

385 Greenwich — **REVISION DIAGRAMS**

PROJECT NUMBER 25.59  
DATE April 21, 2026

**13**



Updated Proposed Design

385 Greenwich — **PROPOSED DESIGN**



**DXA studio**

894 6th Avenue  
5th Floor  
NYC 10001  
T 212 874 0567

[dxastudio.com](http://dxastudio.com)

**PROJECT NUMBER** 25.59  
**DATE** April 21, 2026

**14**



Updated Proposed Design

385 Greenwich — PROPOSED DESIGN



**DXA studio**  
894 6th Avenue  
5th Floor  
NYC 10001  
T 212 874 0567  
dxastudio.com

**PROJECT NUMBER** 25.59  
**DATE** April 21, 2026

**15**



Updated Proposed Design

385 Greenwich — **PROPOSED DESIGN**



**DXA studio**

894 6th Avenue  
5th Floor  
NYC 10001  
T 212 874 0567

[dxastudio.com](http://dxastudio.com)

**PROJECT NUMBER** 25.59  
**DATE** April 21, 2026

**16**



Updated Proposed Design

385 Greenwich — **PROPOSED DESIGN**



**DXA studio**

894 6th Avenue  
5th Floor  
NYC 10001  
T 212 874 0567

[dxastudio.com](http://dxastudio.com)

**PROJECT NUMBER** 25.59  
**DATE** April 21, 2026

**17**



Updated Proposed Design

385 Greenwich — **PROPOSED DESIGN**



**DXA studio**

894 6th Avenue  
5th Floor  
NYC 10001  
T 212 874 0567

[dxastudio.com](http://dxastudio.com)

**PROJECT NUMBER** 25.59  
**DATE** April 21, 2026

**18**



16 N Moore Street  
Built: 1880



385 Greenwich — HISTORIC CONTEXT



**DXA studio**

dxastudio.com

894 6th Avenue  
5th Floor  
NYC 10001  
T 212 874 0567

**PROJECT NUMBER** 25.59  
**DATE** April 21, 2026



347 Bleeker Street  
Built: 1883



411 Bleeker Street  
Built: 1860

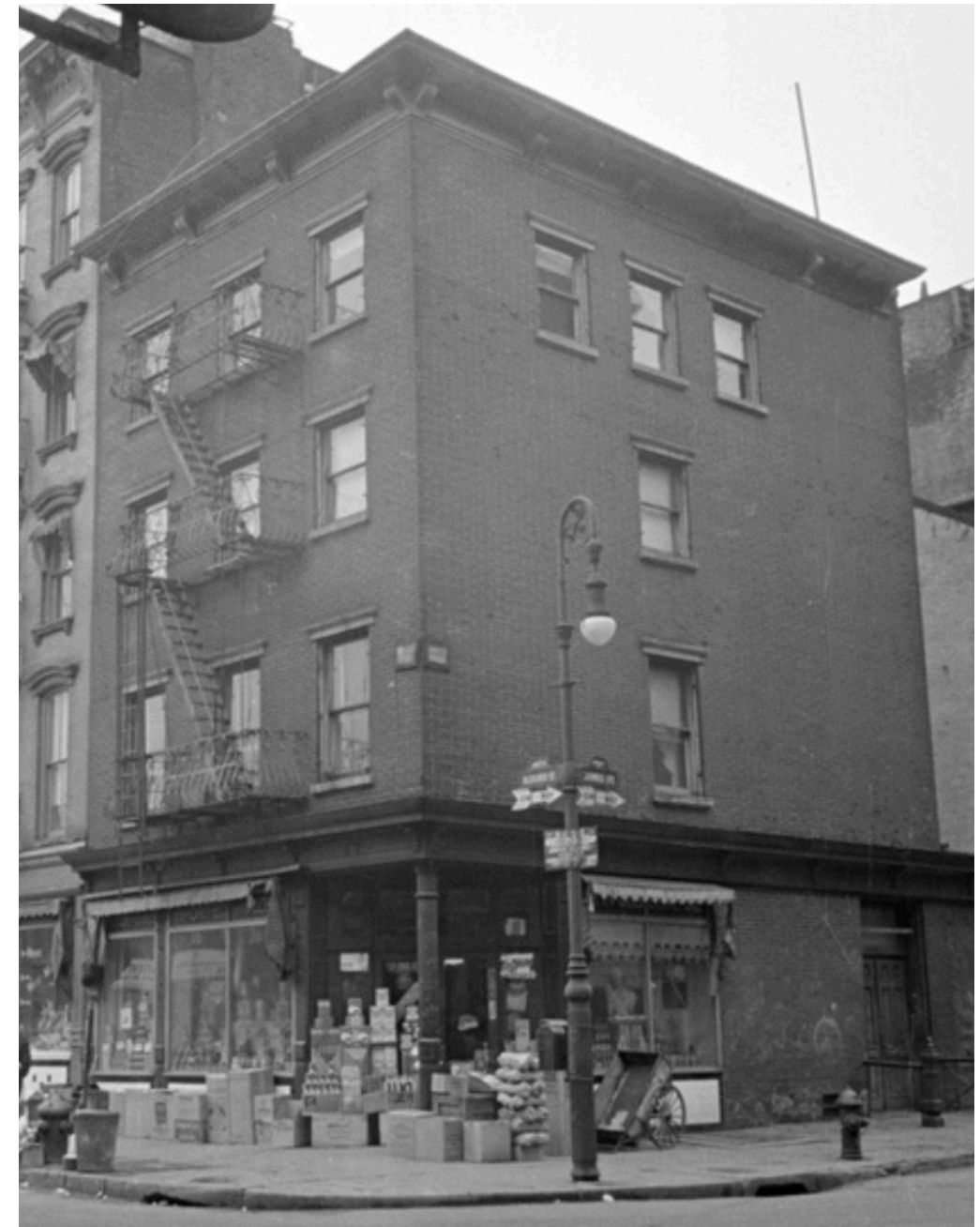

281 Bleeker Street  
Built: 1813  
Storefront Alteration: 1890

385 Greenwich



**DXA studio**

894 6th Avenue  
5th Floor  
NYC 10001  
T 212 874 0567

dxastudio.com

PROJECT NUMBER 25.59  
DATE April 2026

**20**



Updated Proposed Design

385 Greenwich — **PROPOSED DESIGN**



**DXA studio**  
894 6th Avenue  
5th Floor  
NYC 10001  
T 212 874 0567  
dxastudio.com

**PROJECT NUMBER** 25.59  
**DATE** April 21, 2026

**21**

Presented on 03/24/2026

Previously Presented Design



HANDRAILS SET BACK IS INCREASED BY 42" ON GREENWICH STREET

SPANDRELS REDUCED 4" TO COORDINATE WITH REVISED CORNICE DEPTH.

ADDITION BAY WIDENED 8" AT GREENWICH.

Updated Proposed Design

UPPER CORNICE DEPTH REDUCED BY 6"

HANDRAILS SET BACK IS INCREASED BY 12" ON N MOORE STREET

385 Greenwich — PROPOSED DESIGN



**DXA studio**  
894 6th Avenue  
5th Floor  
NYC 10001  
T 212 874 0567  
dxastudio.com

PROJECT NUMBER 25.59  
DATE April 21, 2026

22

Presented on 03/24/2026

Previously Presented Design



Updated Proposed Design



385 Greenwich — PROPOSED DESIGN



**DXA studio**

894 6th Avenue  
5th Floor  
NYC 10001  
T 212 874 0567

[dxastudio.com](http://dxastudio.com)

**PROJECT NUMBER** 25.59  
**DATE** April 21, 2026

**23**

Presented on 03/24/2026

Previously Presented Design



TOP OF STOREFRONT CORNICE ELEVATION INCREASED BY 11"

BOTTOM OF STOREFRONT CORNICE ELEVATION INCREASED BY 12"

Updated Proposed Design



385 Greenwich — PROPOSED DESIGN



DXA studio

894 6th Avenue  
5th Floor  
NYC 10001  
T 212 874 0567

dxastudio.com

PROJECT NUMBER 25.59  
DATE April 21, 2026

24

Presented on 03/24/2026



Previously Presented Design



Updated Proposed Design

385 Greenwich — **PROPOSED DESIGN**



**DXA studio**

dxastudio.com

894 6th Avenue  
5th Floor  
NYC 10001  
T 212 874 0567

**PROJECT NUMBER** 25.59  
**DATE** April 21, 2026

**25**

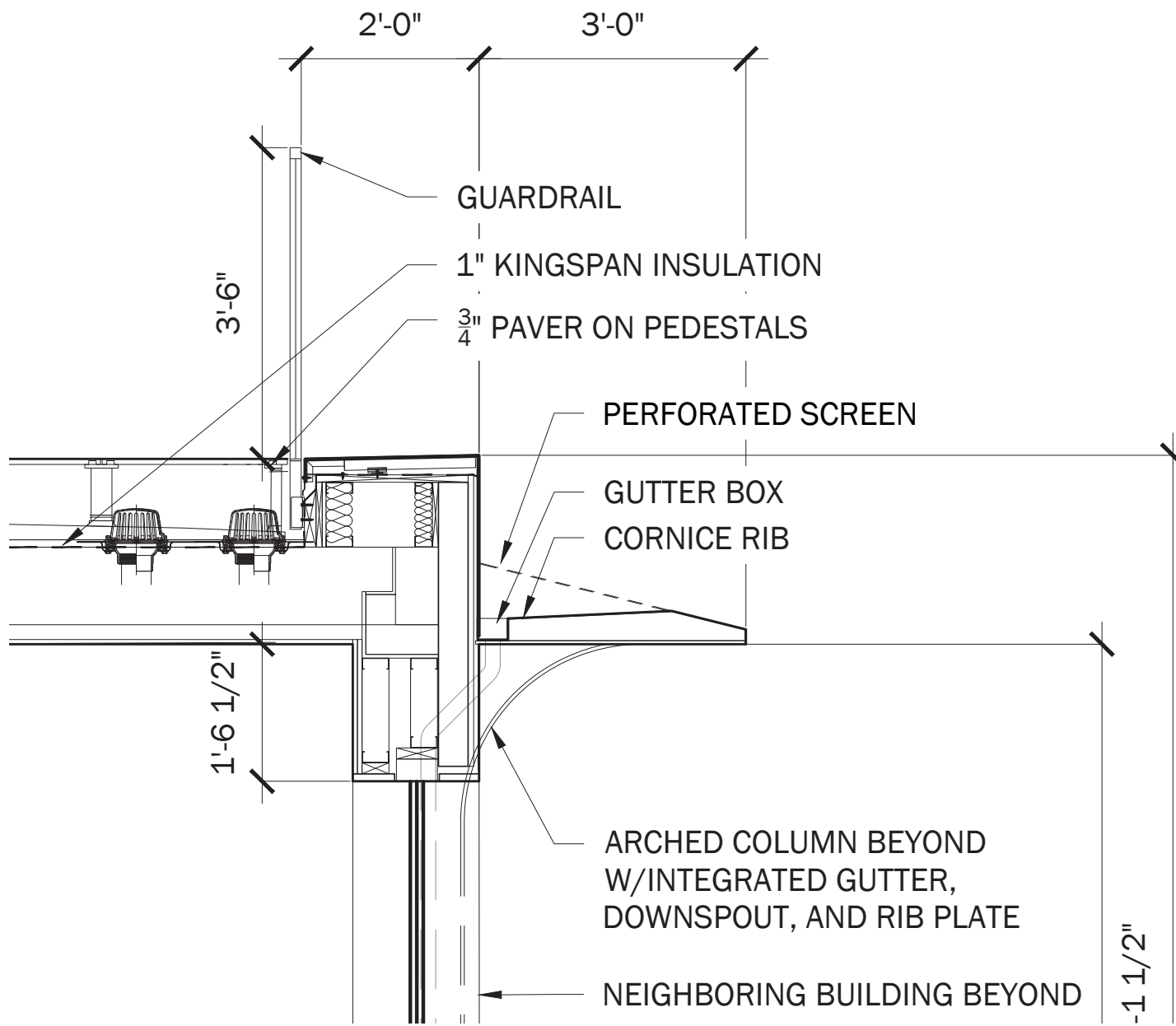

PREVIOUSLY PROPOSED CROWN DETAIL SECTION

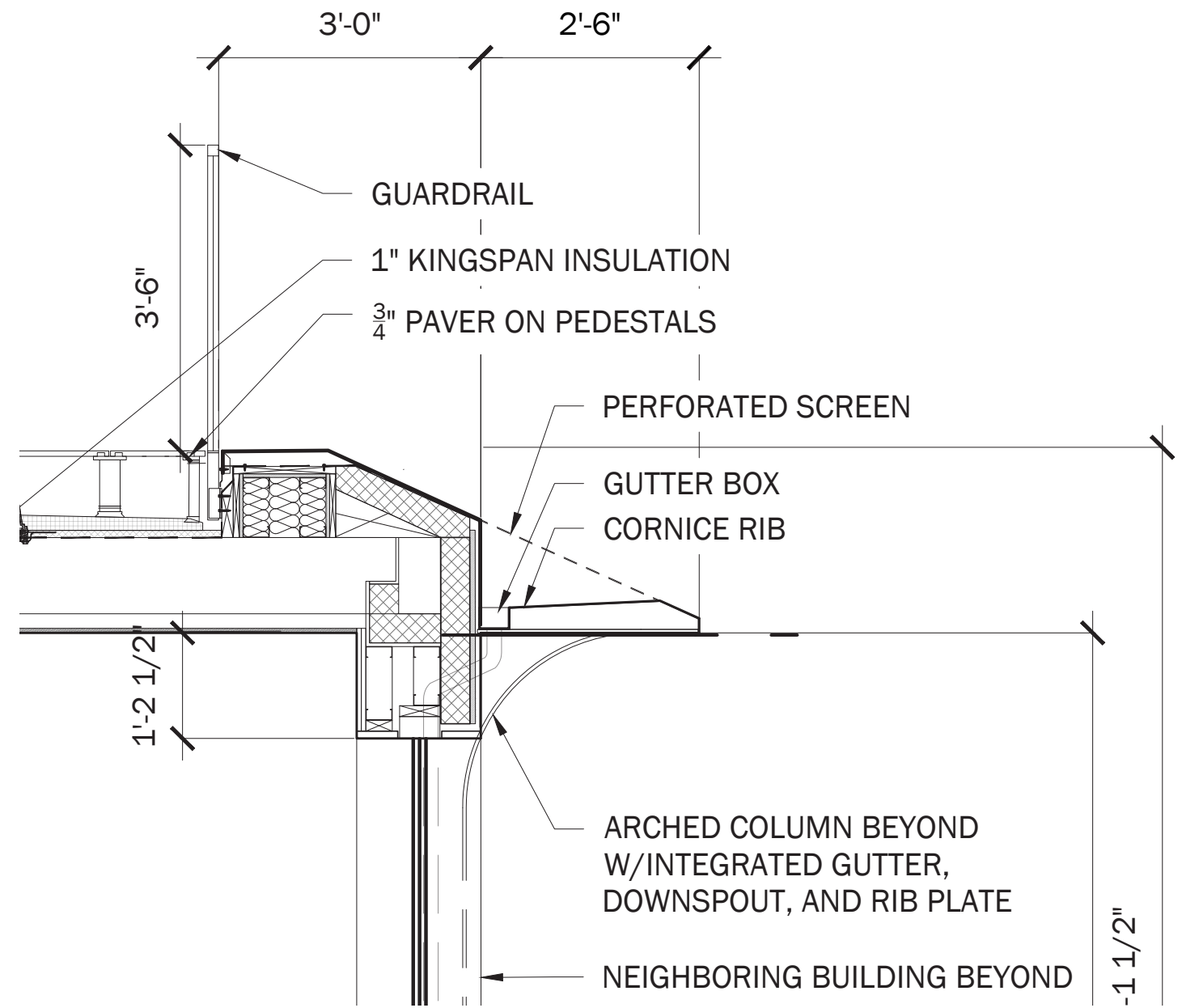

PROPOSED CROWN DETAIL SECTION



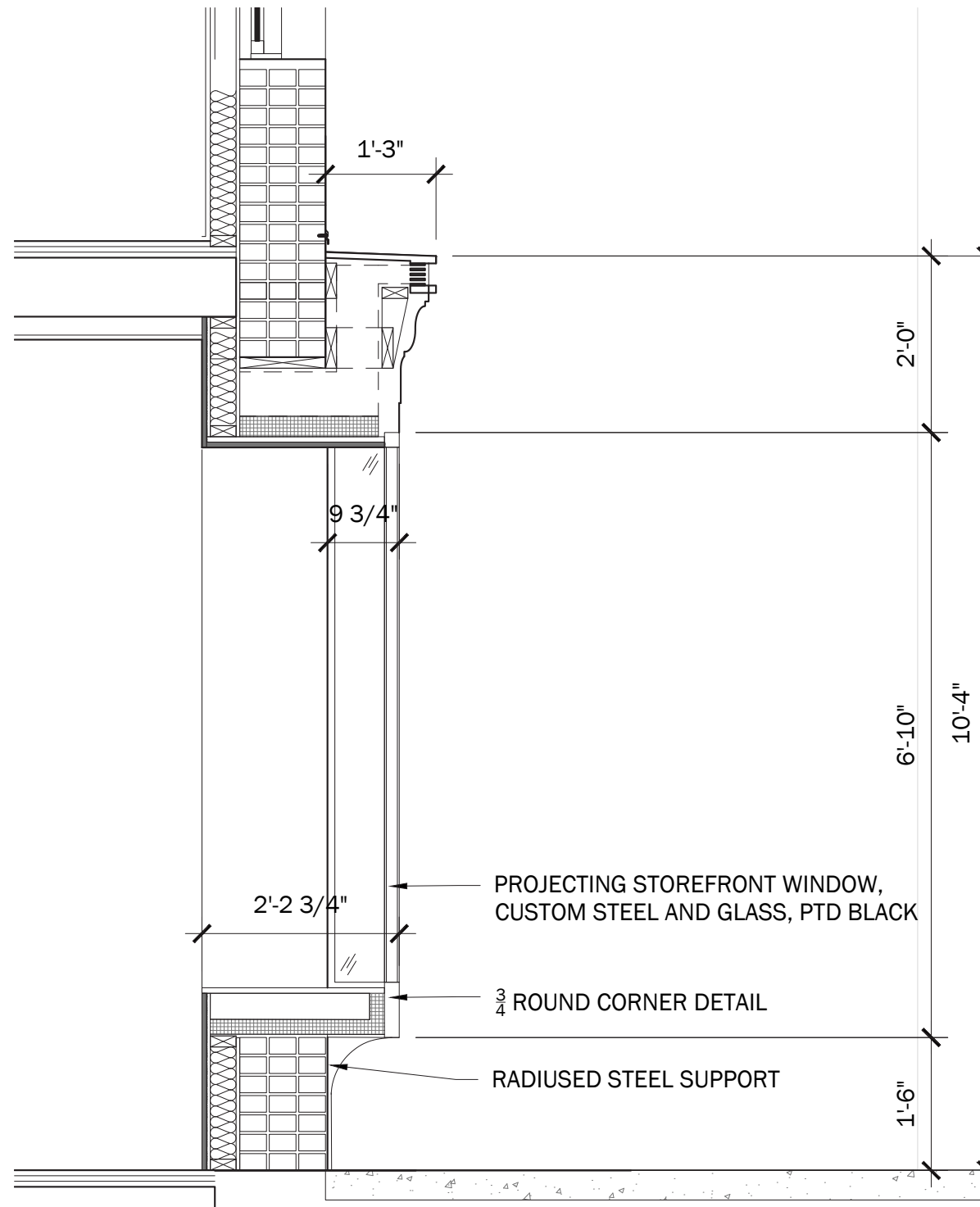

PREVIOUSLY PROPOSED BAY WINDOW DETAIL SECTION

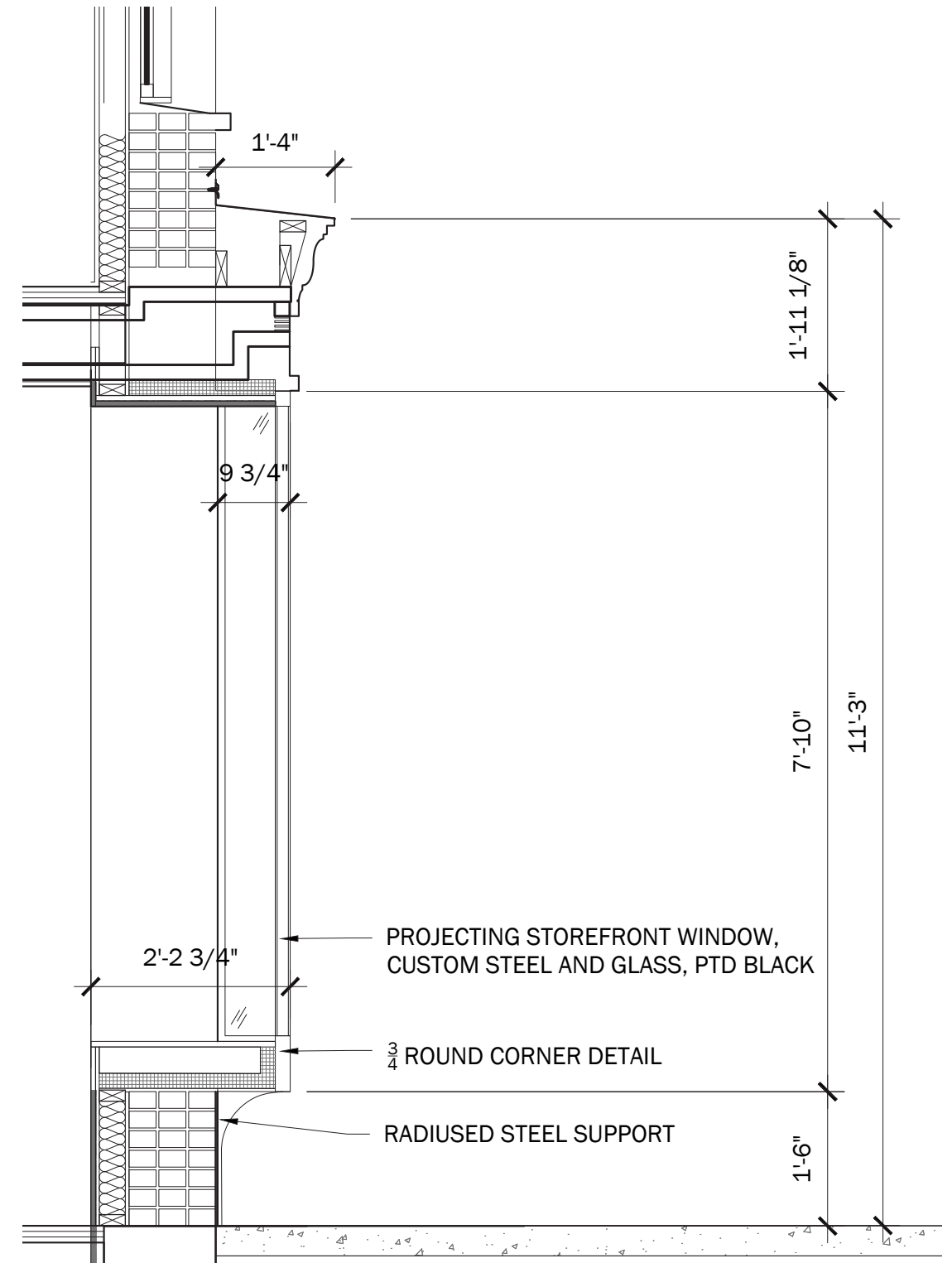

PROPOSED BAY WINDOW DETAIL SECTION

385 Greenwich — **PROPOSED TRANSVERSE SECTIONS**



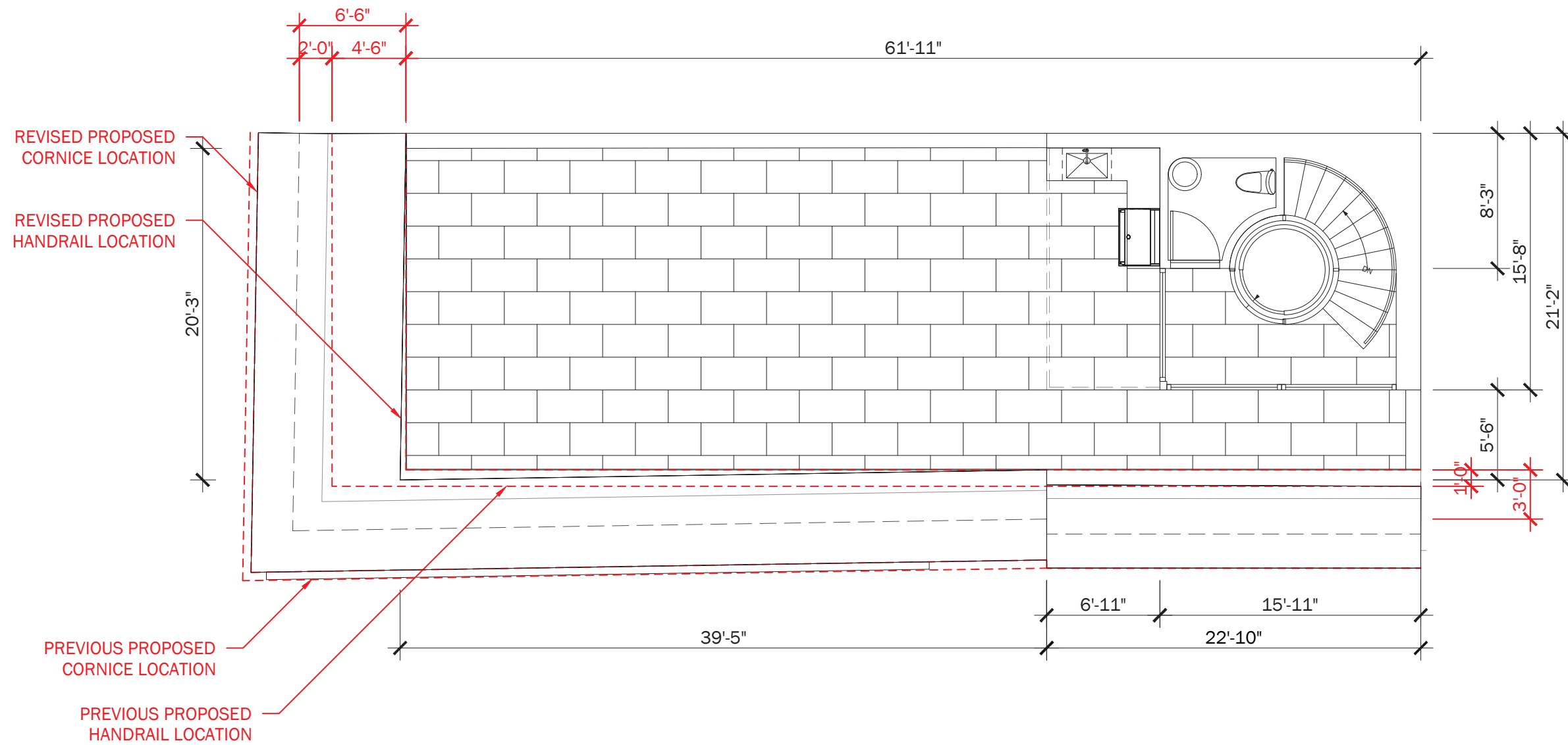

385 Greenwich — **PROPOSED HANDRAIL AND CORNICE REVISIONS**



**DXA studio**  
 894 6th Avenue  
 5th Floor  
 NYC 10001  
 T 212 874 0567  
 dxastudio.com

**PROJECT NUMBER** 25.59  
**DATE** April 21, 2026

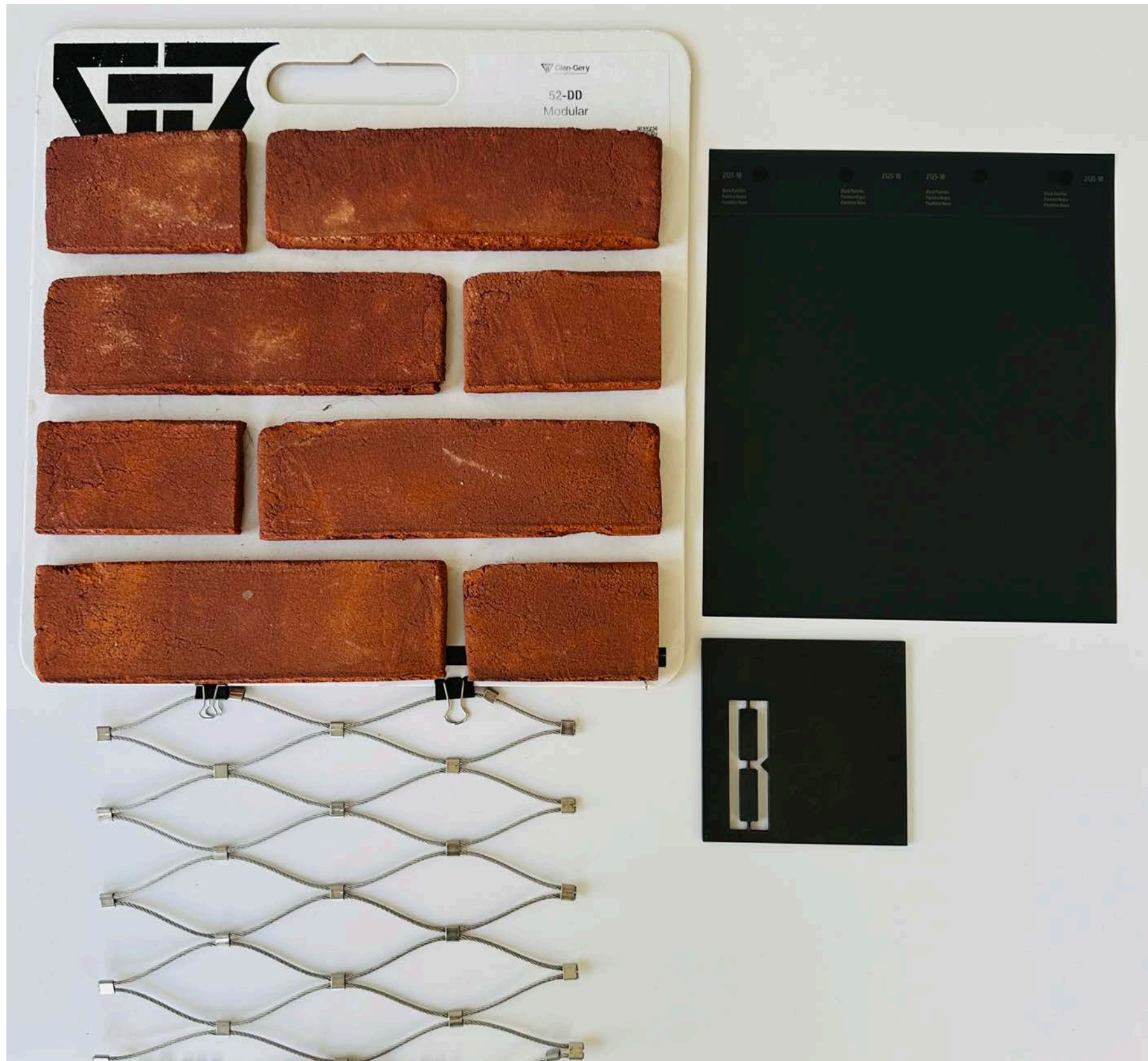

385 Greenwich — **PROPOSED ROOF DECK RAILING**



**DXA studio**  
894 6th Avenue  
5th Floor  
NYC 10001  
T 212 874 0567  
dxastudio.com

**PROJECT NUMBER** 25.59  
**DATE** April 21, 2026



VIEW 3: N MOORE ST 0' | **MOCKUP PHOTO WITH VISIBILITY**

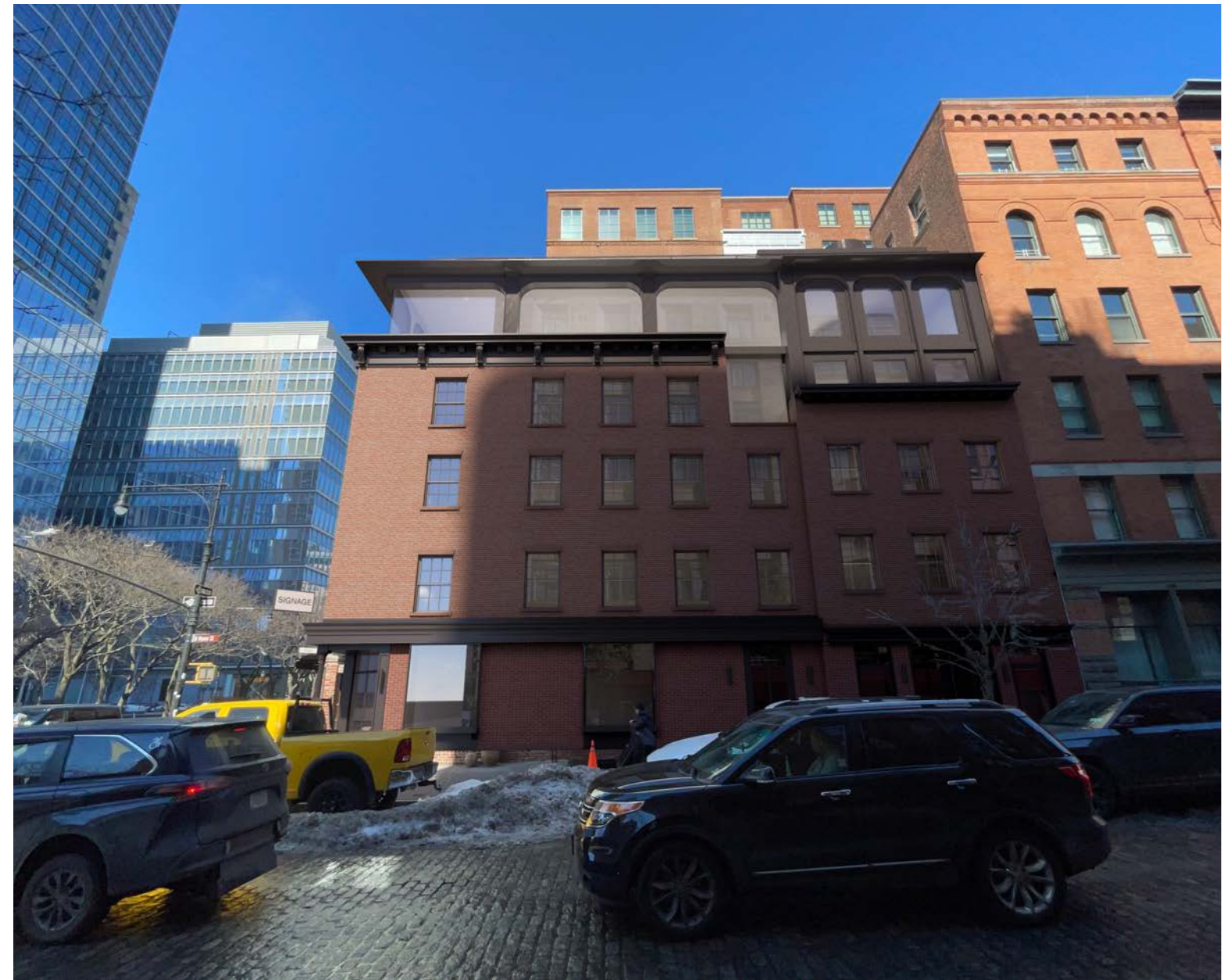

VIEW 3: N MOORE ST 0' | **PROPOSED**

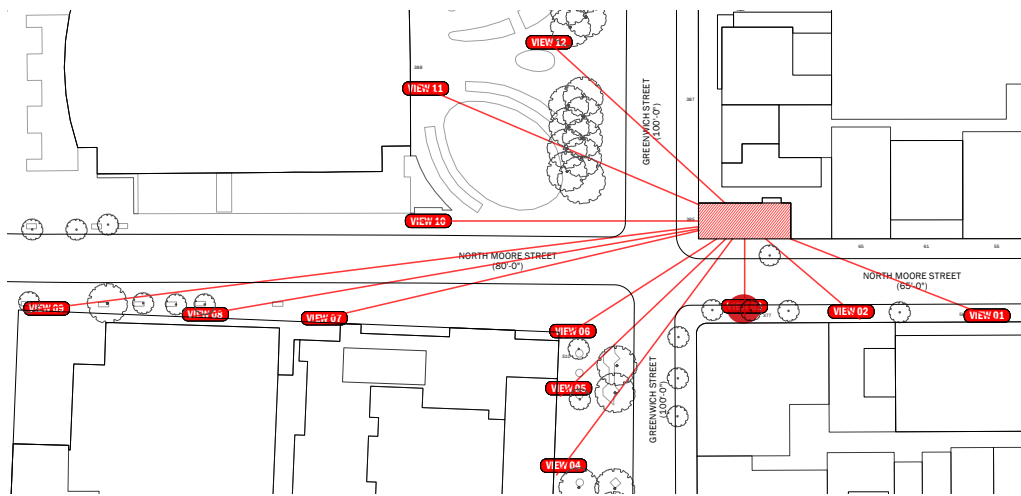

**DXA studio**  
 894 6th Avenue  
 5th Floor  
 NYC 10001  
 T 212 874 0567  
 dxastudio.com

**385 GREENWICH | VISIBILITY STUDIES**

NTS  
**PROJECT NUMBER** 25.59  
**DATE** April 21, 2026

**30**



VIEW 5: GREENWICH ST -120' | **MOCKUP PHOTO WITH VISIBILITY**



VIEW 5: GREENWICH ST -120' | **PROPOSED**

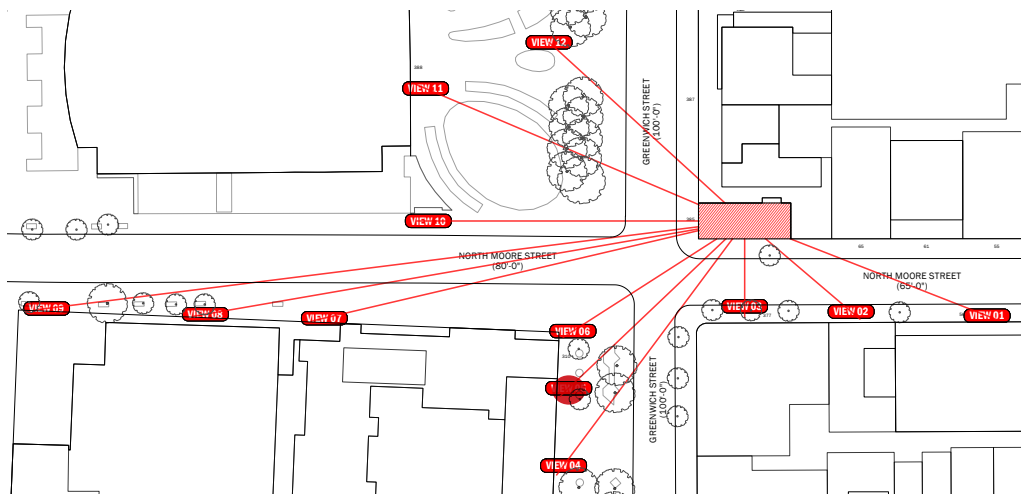

**385 GREENWICH | VISIBILITY STUDIES**



**DXA studio**  
 894 6th Avenue  
 5th Floor  
 NYC 10001  
 T 212 874 0567  
 dxastudio.com

NTS  
**PROJECT NUMBER** 25.59  
**DATE** April 21, 2026

**31**



VIEW 8: N MOORE ST. -390' | **MOCKUP PHOTO WITH VISIBILITY**



VIEW 8: N MOORE ST. -390' | **PROPOSED**

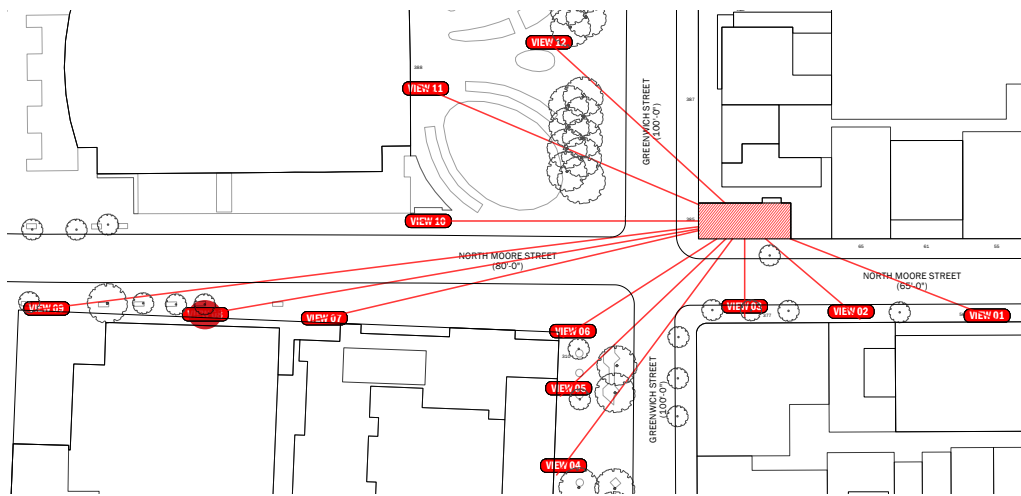

385 GREENWICH | **VISIBILITY STUDIES**



**DXA studio**  
 894 6th Avenue  
 5th Floor  
 NYC 10001  
 T 212 874 0567  
 dxastudio.com

NTS  
**PROJECT NUMBER** 25.59  
**DATE** April 21, 2026



VIEW 12: GREENWICH ST +135' | **MOCKUP PHOTO WITH VISIBILITY**



VIEW 12: GREENWICH ST +135' | **PROPOSED**

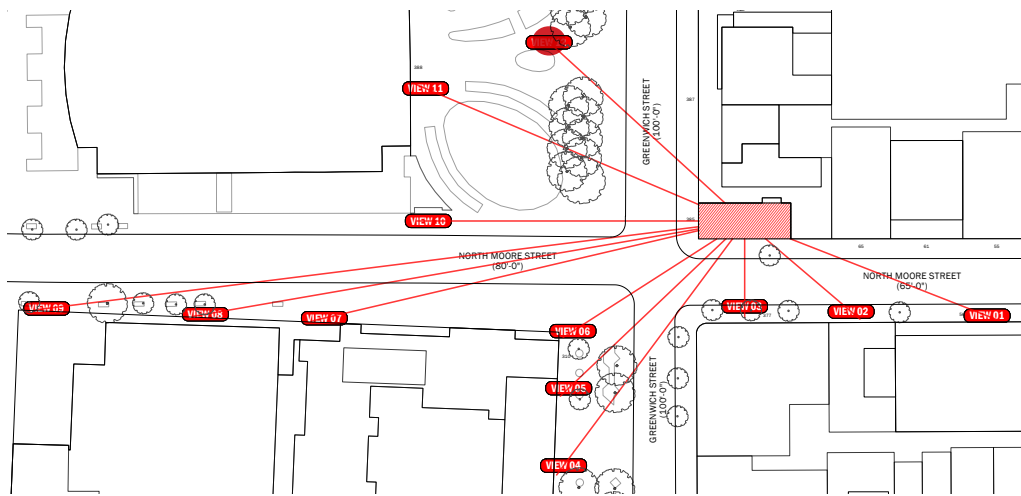

**DXA studio**  
 894 6th Avenue  
 5th Floor  
 NYC 10001  
 T 212 874 0567  
 dxastudio.com

**385 GREENWICH | VISIBILITY STUDIES**

NTS  
**PROJECT NUMBER** 25.59  
**DATE** April 21, 2026



385 Greenwich — PREVIOUSLY PROPOSED DESIGN



**DXA studio**

[dxastudio.com](http://dxastudio.com)

894 6th Avenue  
5th Floor  
NYC 10001  
T 212 874 0567

**PROJECT NUMBER** 25.59  
**DATE** April 21, 2026

**34**



Updated Proposed Design

385 Greenwich — **PROPOSED DESIGN**



**DXA studio**

894 6th Avenue  
5th Floor  
NYC 10001  
T 212 874 0567

[dxastudio.com](http://dxastudio.com)

**PROJECT NUMBER** 25.59  
**DATE** April 21, 2026

**35**

**THANK YOU**

The current proposal is:

**Preservation Department – Item 3, LPC-26-06268**

**385 Greenwich Street – Tribeca West Historic District**  
**Borough of Manhattan**

**Note: this is a Public Meeting item. No public testimony will be received today as the hearing on this item is closed.**

WM

**APPENDIX**



Google Maps, 2025



**DXA studio**

dxastudio.com

894 6th Avenue  
5th Floor  
NYC 10001  
T 212 874 0567

385 Greenwich

**PROJECT NUMBER** 25.59  
**DATE** April 21, 2026

**38**



2025



2025

385 Greenwich — EXISTING CONDITIONS



**DXA studio**

894 6th Avenue  
5th Floor  
NYC 10001  
T 212 874 0567

dxastudio.com

PROJECT NUMBER 25.59  
DATE April 21, 2026

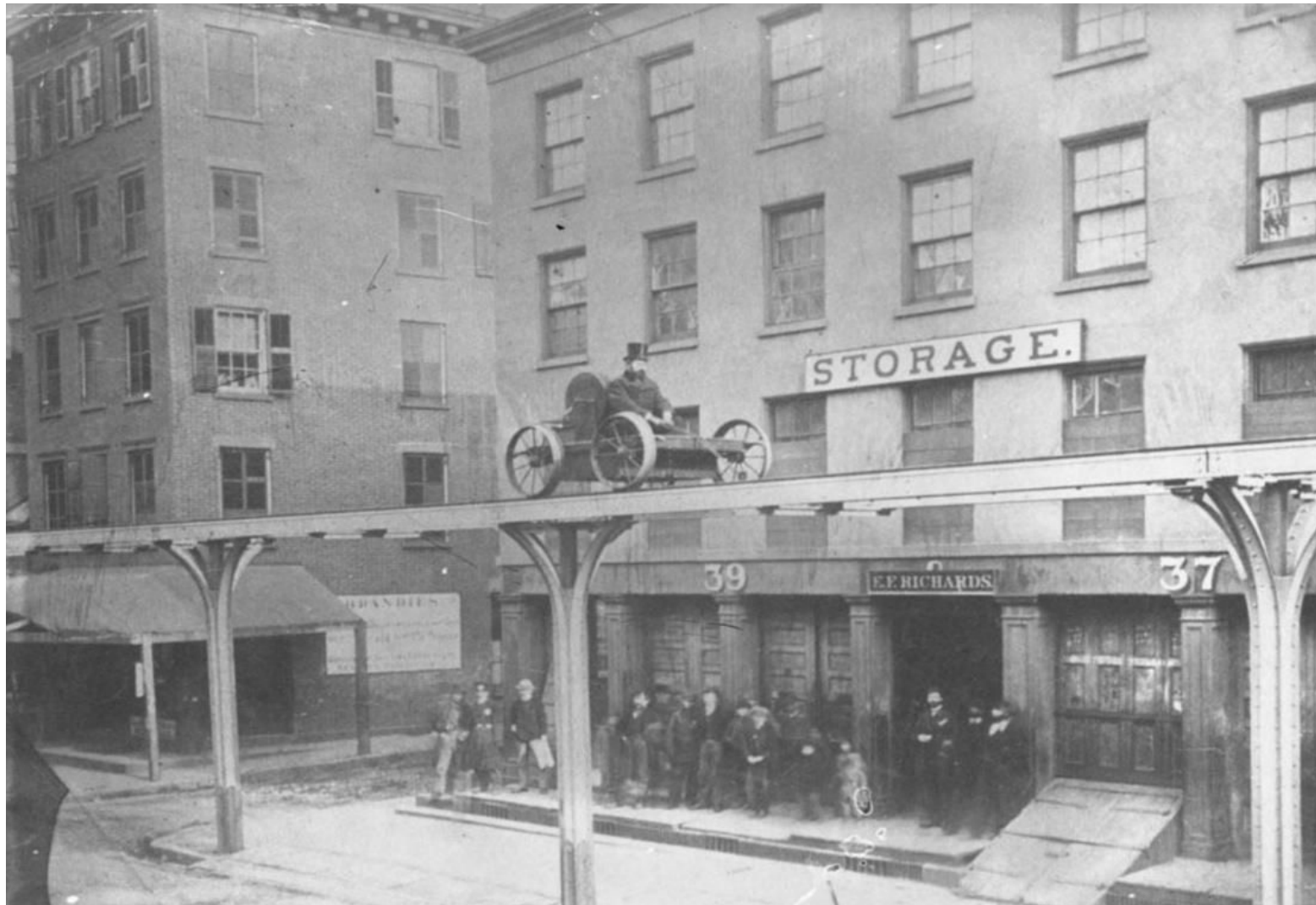

Greenwich Street (1867, Museum of the City of New York)



Greenwich Street (1870s, The Metropolitan Museum of Art)





1940 (Tax Photo)



1940 (Tax Photo)





1991 (LPC Designation Photo)



1991 (LPC Designation Photo)





Greenwich Street (1914, Old NYC Photos)



Greenwich Street (1914, Old NYC Photos)



**DXA studio**

dxastudio.com

894 6th Avenue  
5th Floor  
NYC 10001  
T 212 874 0567

385 Greenwich — **HISTORIC CONTEXT**

**PROJECT NUMBER** 25.59  
**DATE** April 21, 2026

**43**



PREVIOUSLY PROPOSED SOUTH ELEVATION



PROPOSED SOUTH ELEVATION

385 Greenwich — **PROPOSED ELEVATIONS**



**DXA studio**

894 6th Avenue  
5th Floor  
NYC 10001  
T 212 874 0567

dxastudio.com

**PROJECT NUMBER** 25.59  
**DATE** April 21, 2026



PREVIOUSLY PROPOSED WEST ELEVATION



PROPOSED WEST ELEVATION





1 PROPOSED ELEVATION - SOUTH 1/8" = 1'-0"

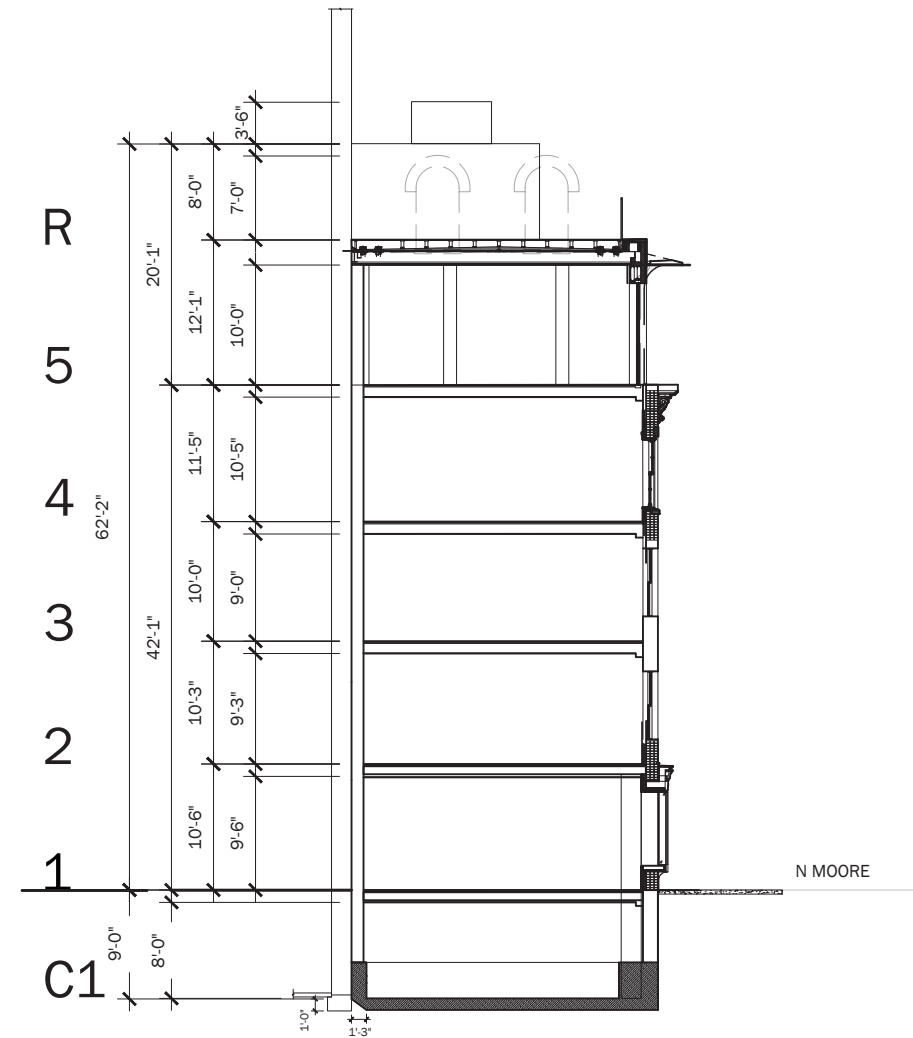

PREVIOUSLY PROPOSED TRAVERSE SECTION

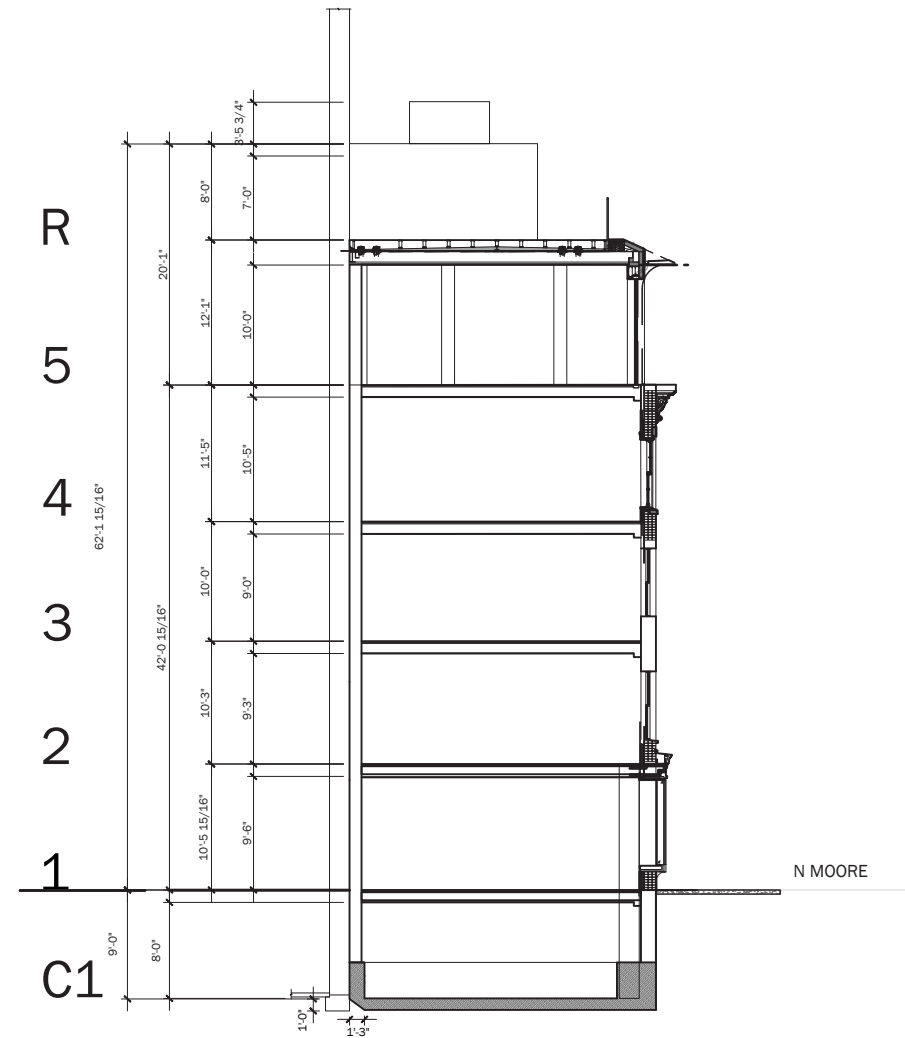

PROPOSED TRAVERSE SECTION

385 Greenwich — PROPOSED TRANSVERSE SECTIONS



**DXA studio**  
894 6th Avenue  
5th Floor  
NYC 10001  
T 212 874 0567  
dxastudio.com

**PROJECT NUMBER** 25.59  
**DATE** April 21, 2026

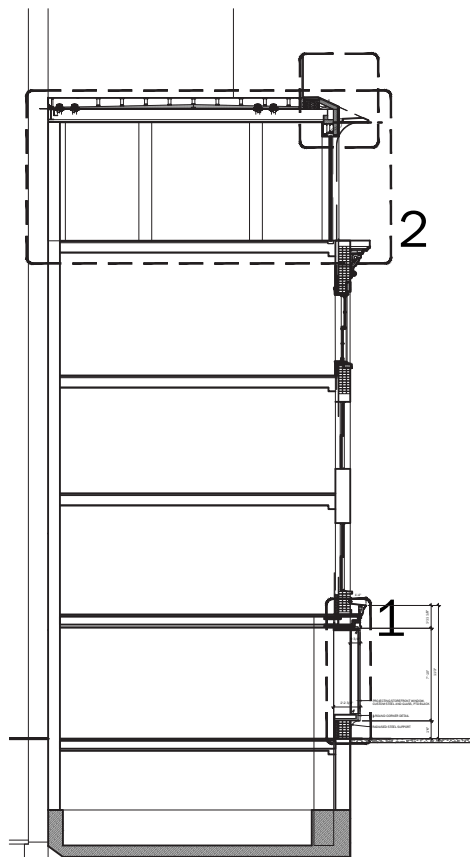

SECTION DETAIL KEY

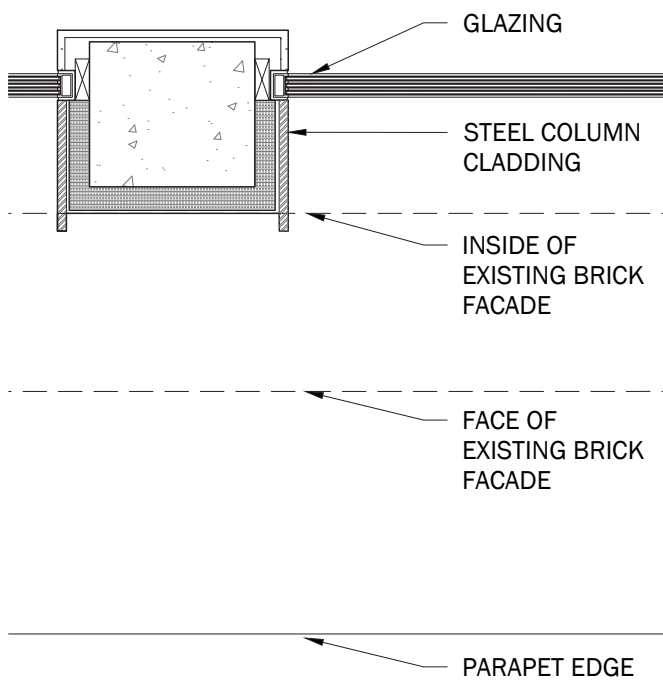

1 PLAN SECTION AT 5TH FL TYP. COL. 3/4" = 1'-0"

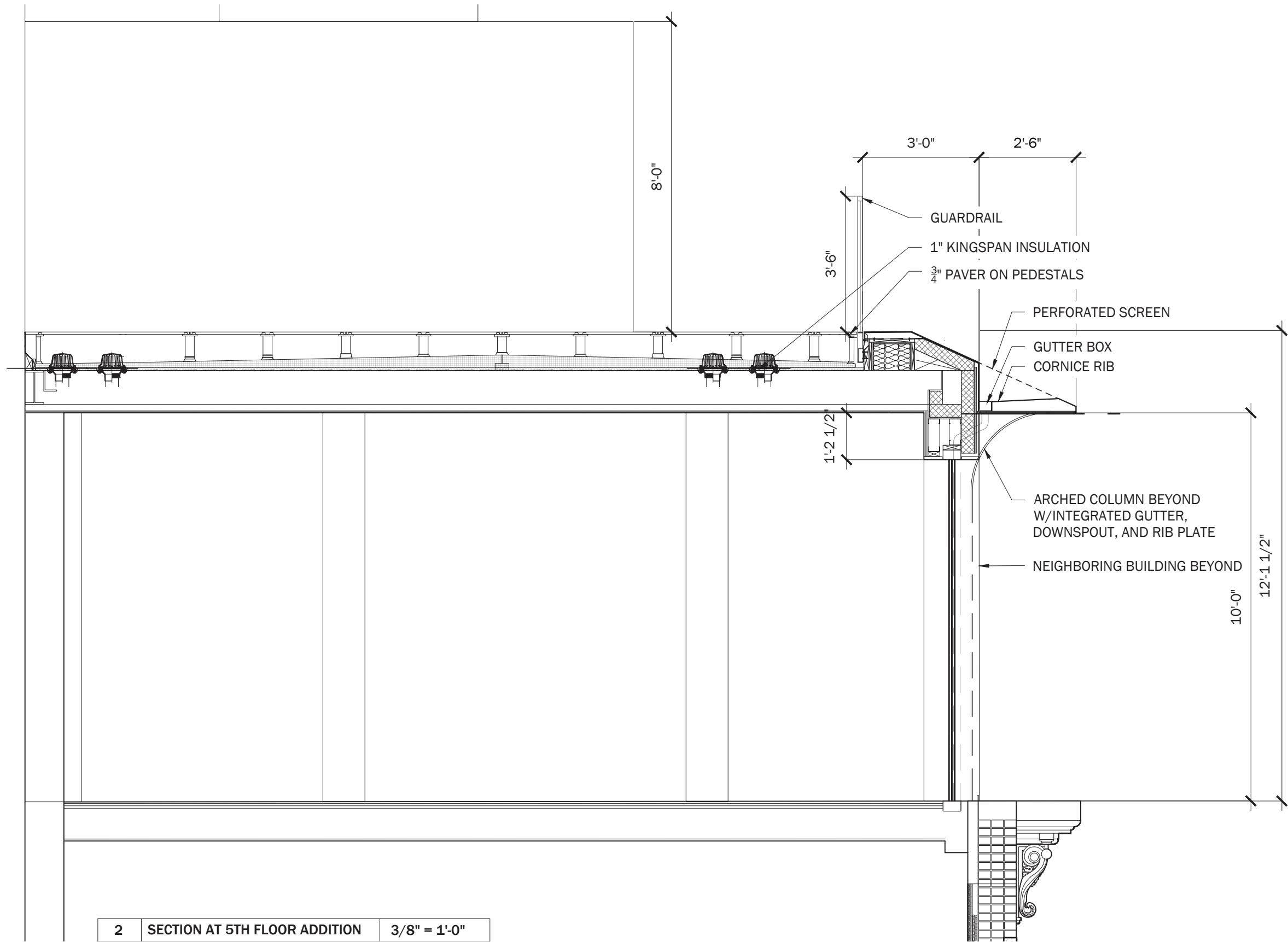

2 SECTION AT 5TH FLOOR ADDITION 3/8" = 1'-0"

385 Greenwich – AMENDED ROOFTOP ADDITION SECTION



**DXA studio**

894 6th Avenue  
5th Floor  
NYC 10001  
T 212 874 0567

dxastudio.com

PROJECT NUMBER 25.59  
DATE April 21, 2026

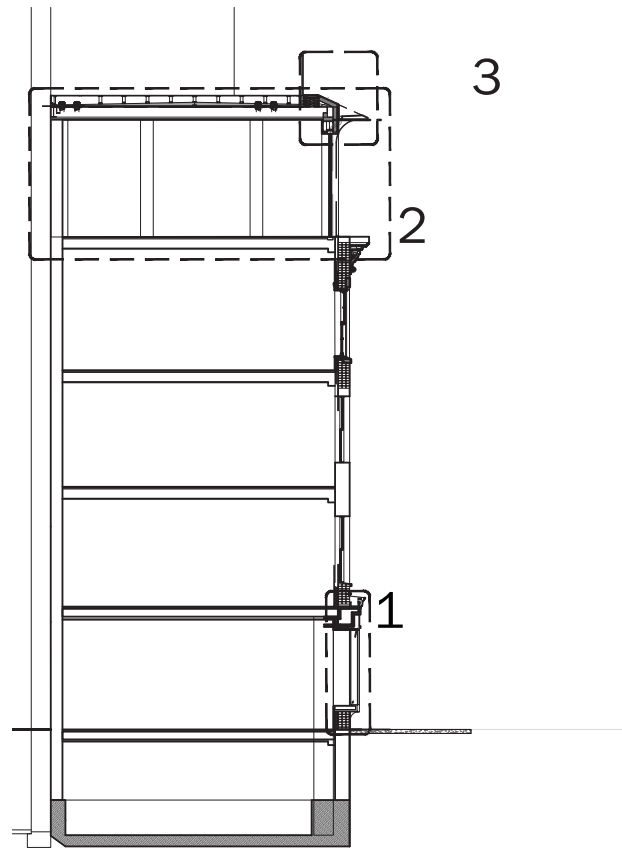

SECTION DETAIL KEY

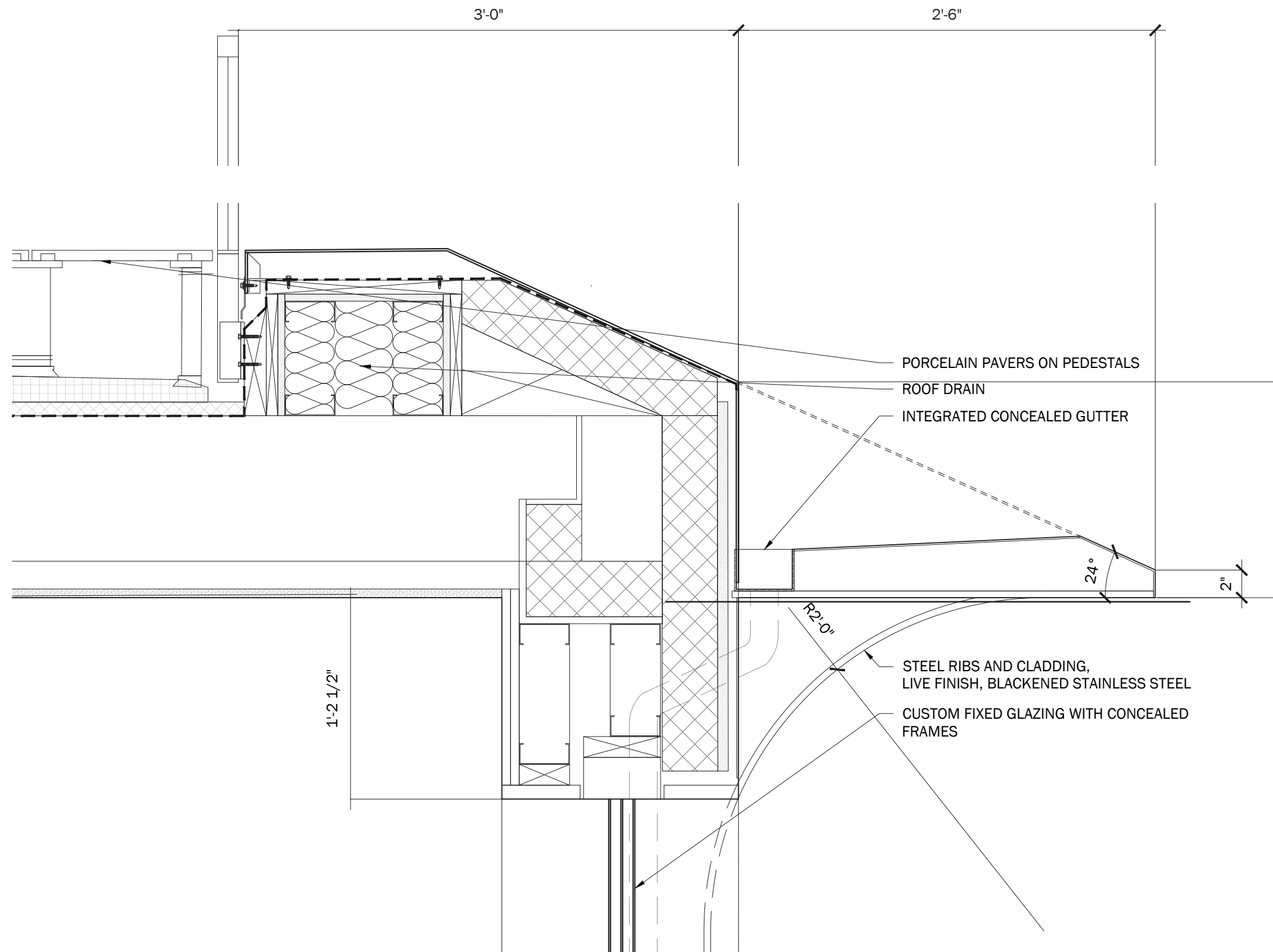

3	ROOFTOP ADDITION HEAD DETAIL	1 1/2" = 1'-0"
---	------------------------------	----------------

385 Greenwich — AMENDED 5TH FLOOR CORNICE DETAILS



DXA studio

dxastudio.com

894 6th Avenue  
5th Floor  
NYC 10001  
T 212 874 0567

PROJECT NUMBER 25.59  
DATE April 21, 2026

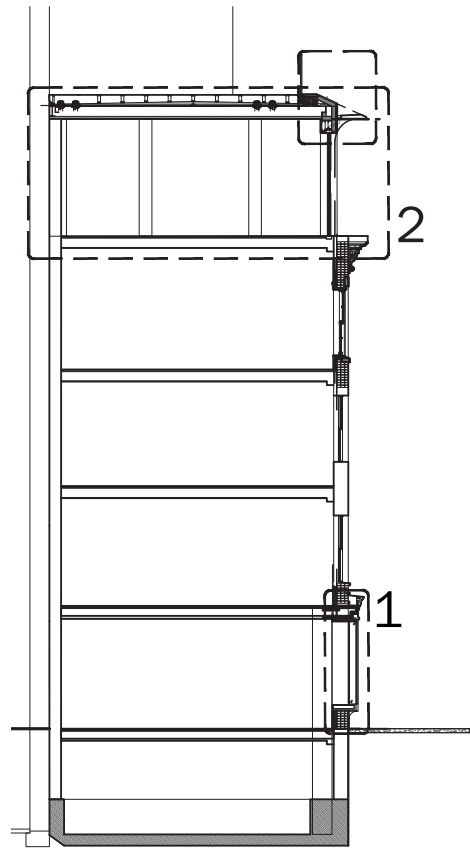

SECTION DETAIL KEY

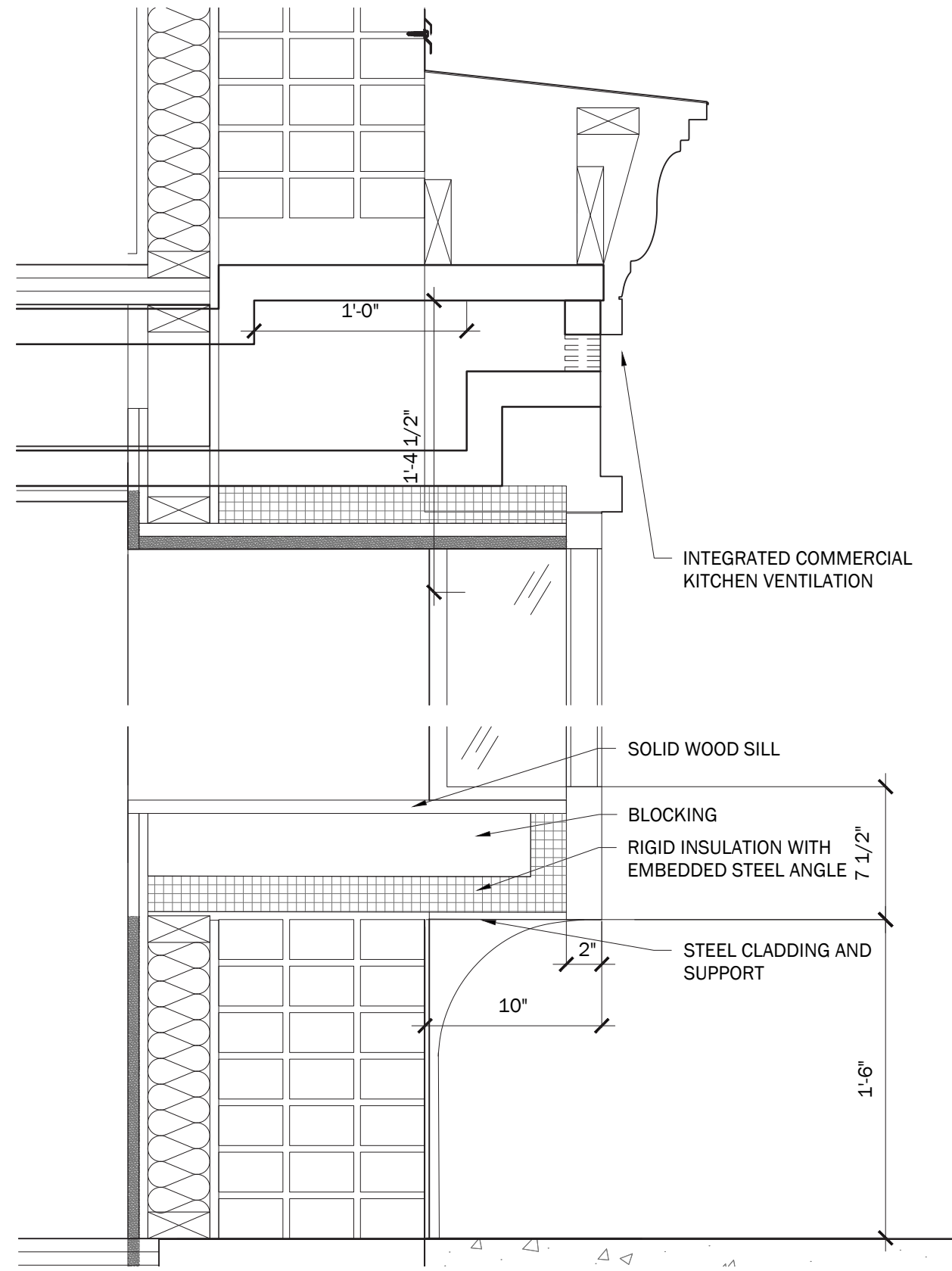

1 PROJECTING WINDOW HEAD & SILL 1 1/2" = 1'-0"

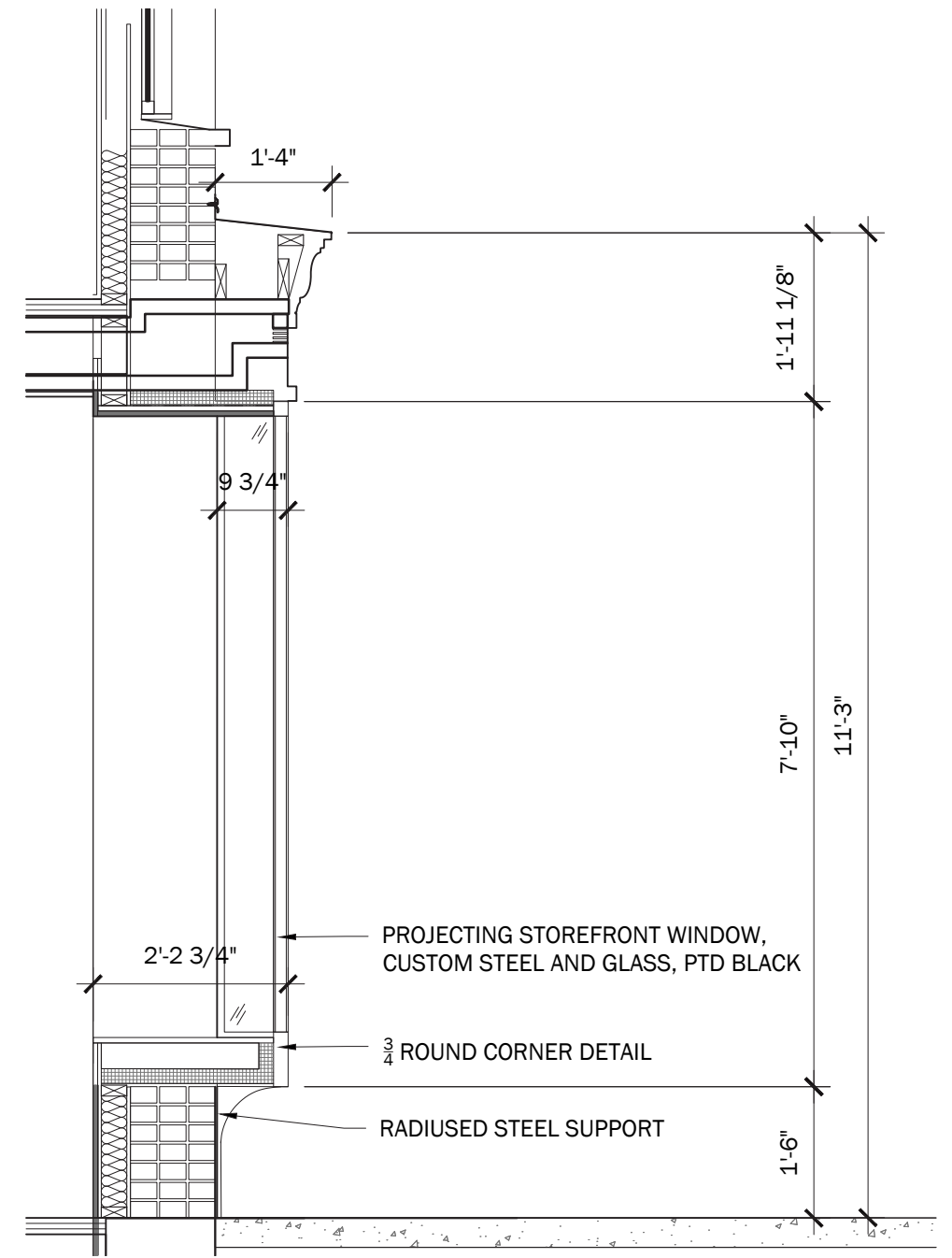

1 PROJECTING STOREFRONT WINDOW 1/2" = 1'-0"

385 Greenwich – AMENDED SECTION DETAILS



**DXA studio**  
 894 6th Avenue  
 5th Floor  
 NYC 10001  
 T 212 874 0567  
 dxastudio.com

**PROJECT NUMBER** 25.59  
**DATE** April 21, 2026

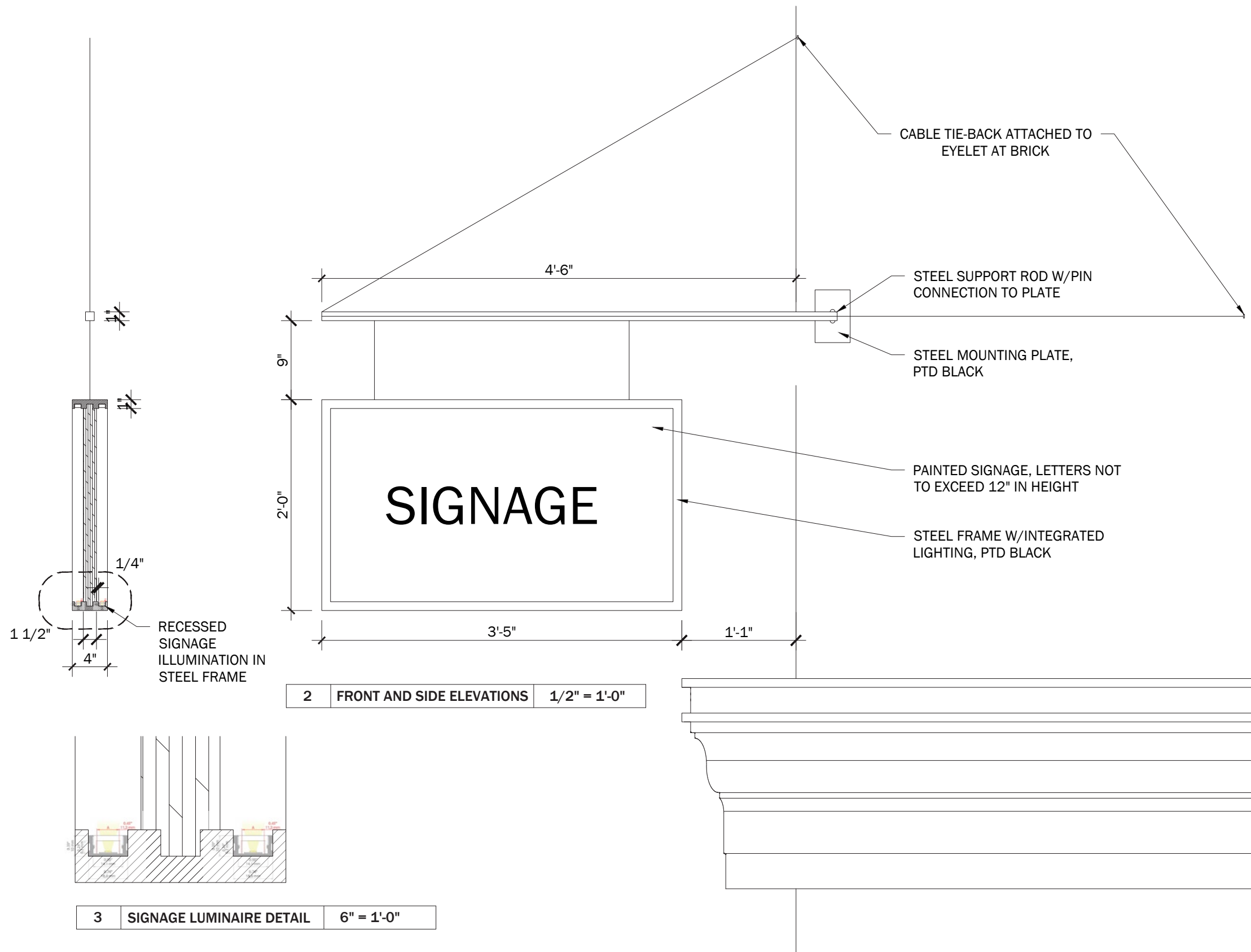

2 FRONT AND SIDE ELEVATIONS 1/2" = 1'-0"

3 SIGNAGE LUMINAIRE DETAIL 6" = 1'-0"



1 ELEVATION DETAIL 1/4" = 1'-0"

385 Greenwich — AMENDED PROPOSED CORNER SIGN



**DXA studio**  
894 6th Avenue  
5th Floor  
NYC 10001  
dxastudio.com T 212 874 0567

PROJECT NUMBER 25.59  
DATE April 21, 2026

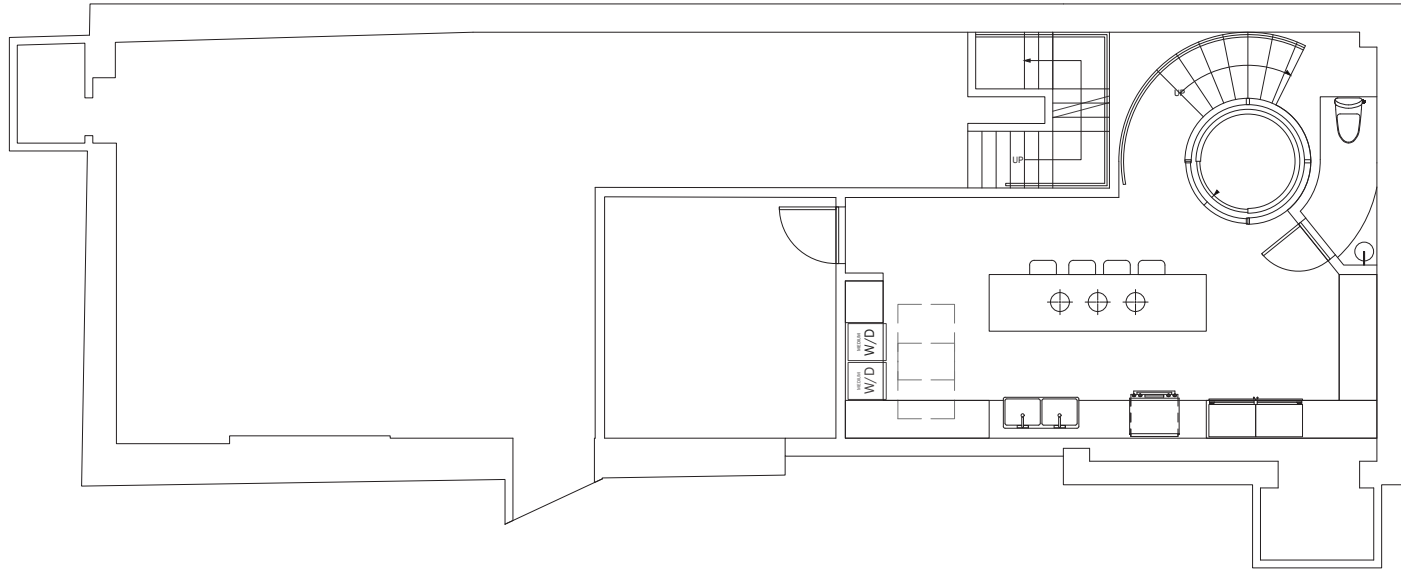

CELLAR PLAN

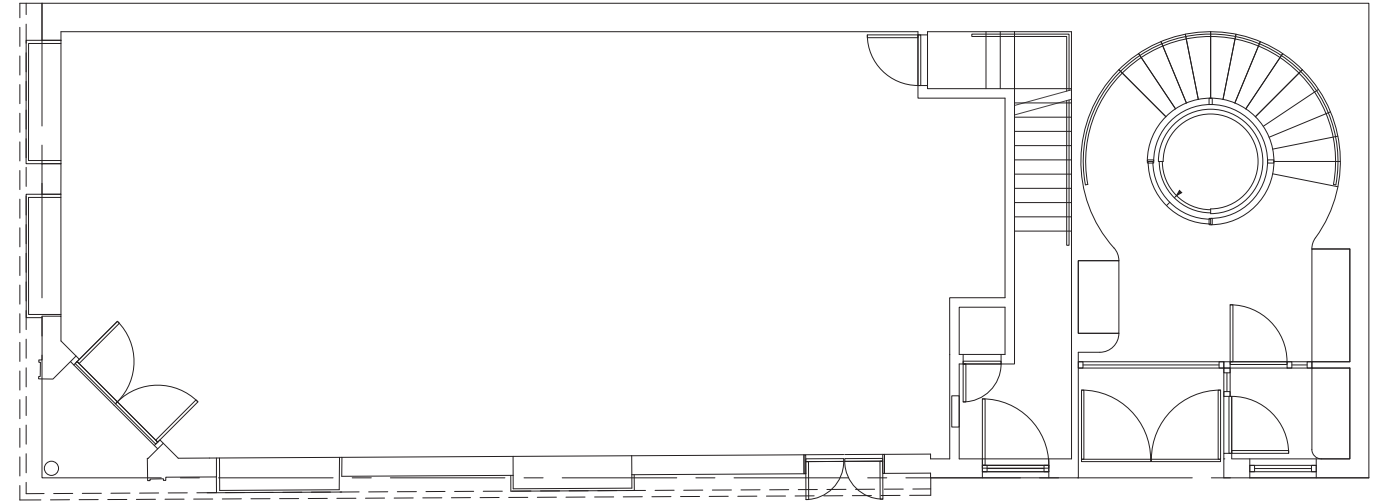

GROUND FLOOR PLAN

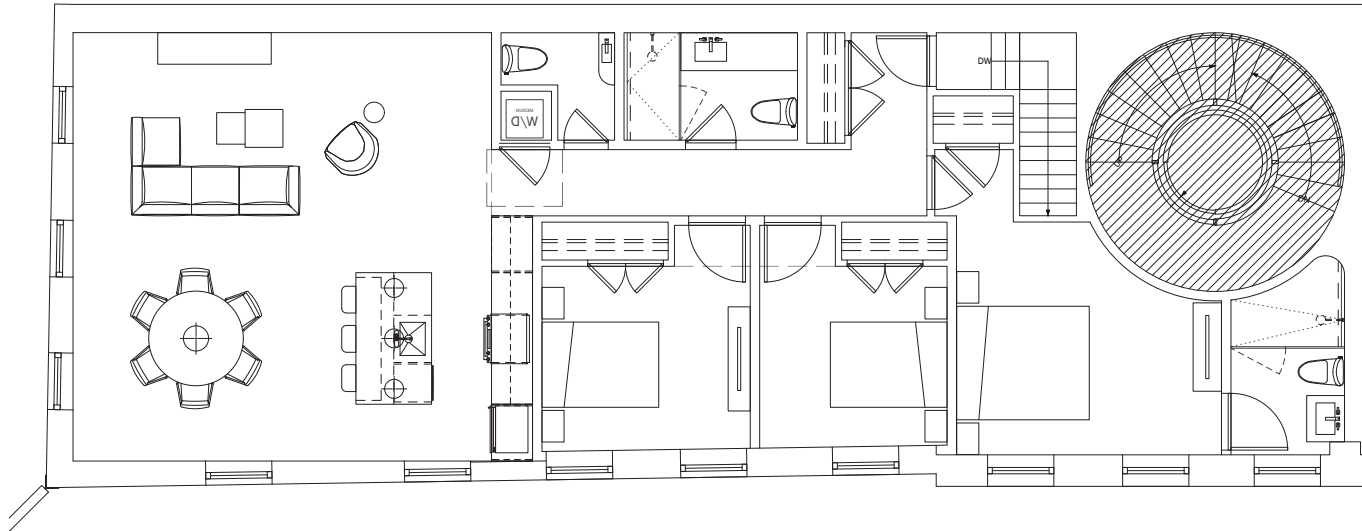

2ND FLOOR PLAN

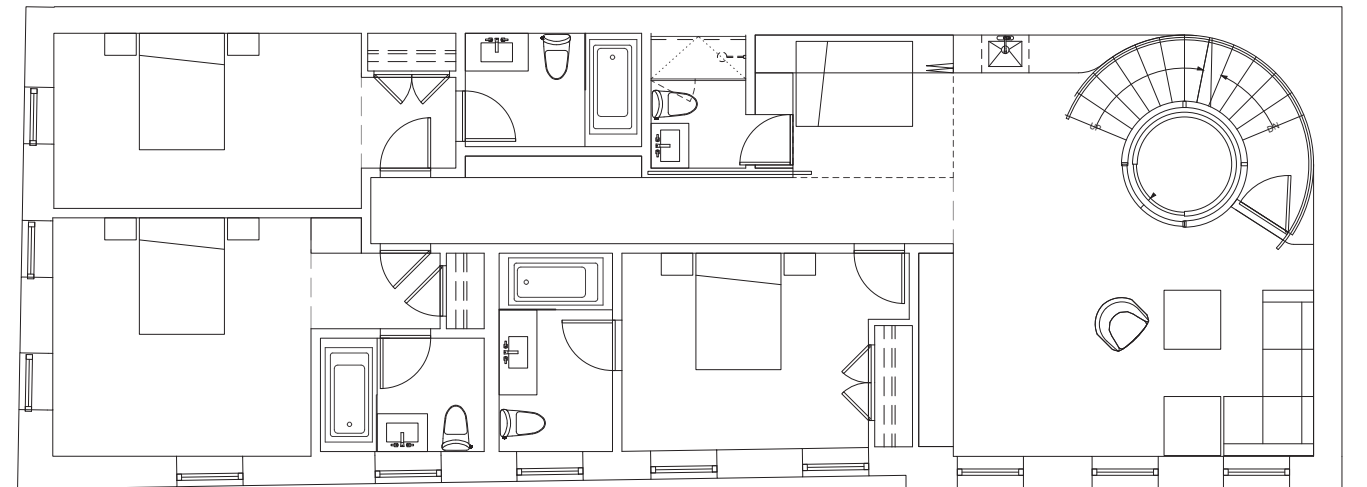

3RD FLOOR PLAN

385 Greenwich — **PROPOSED PLANS**



**DXA studio**

894 6th Avenue  
5th Floor  
NYC 10001  
T 212 874 0567

dxastudio.com

**PROJECT NUMBER** 25.59  
**DATE** April 21, 2026

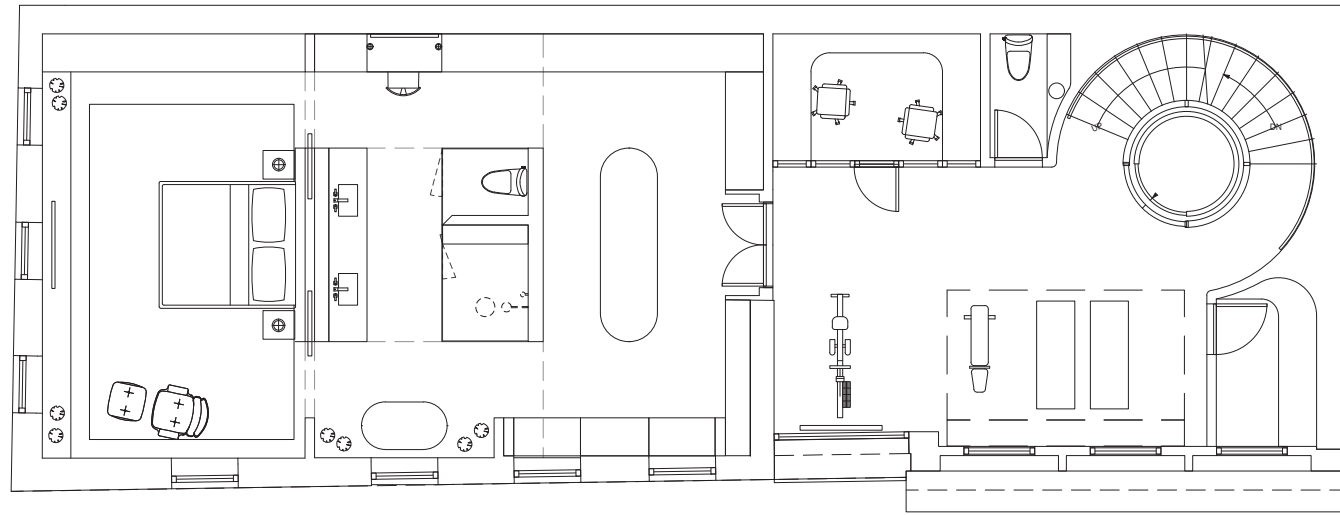

4TH FLOOR PLAN

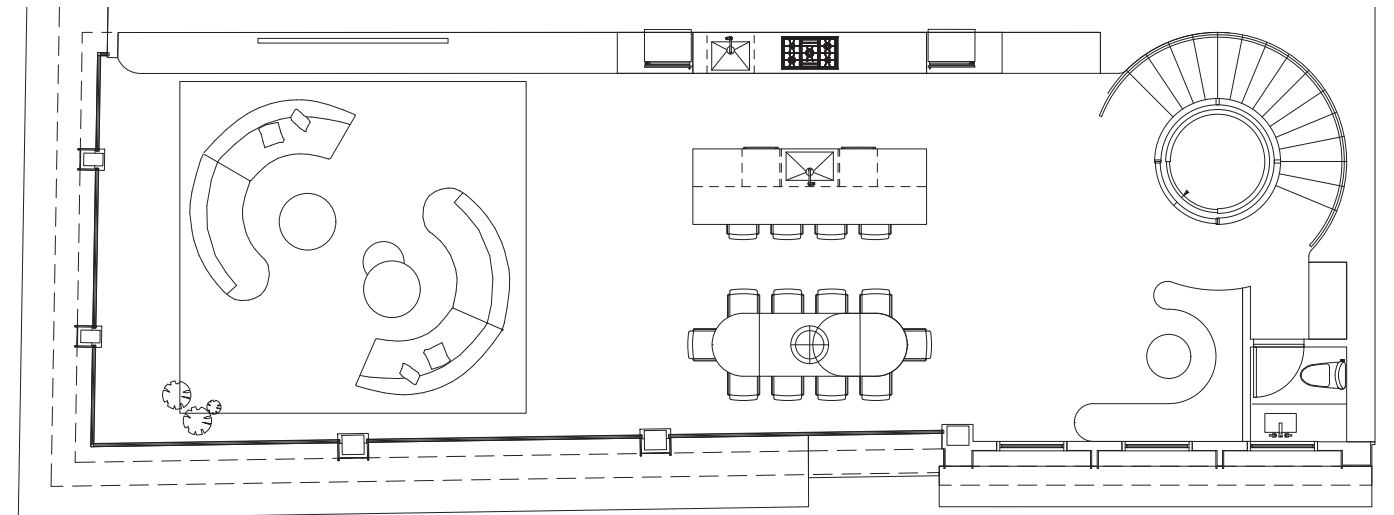

5TH FLOOR PLAN

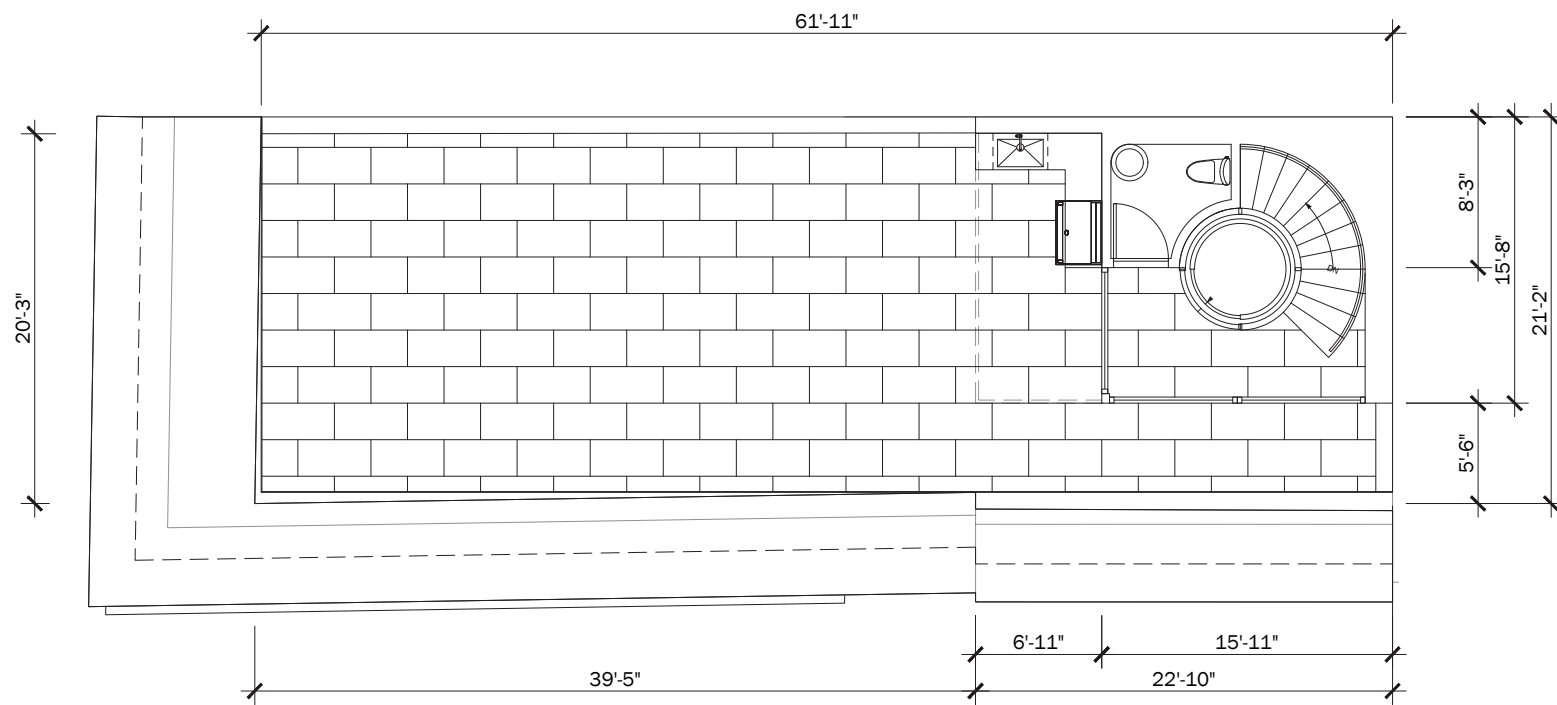

ROOFTOP PLAN

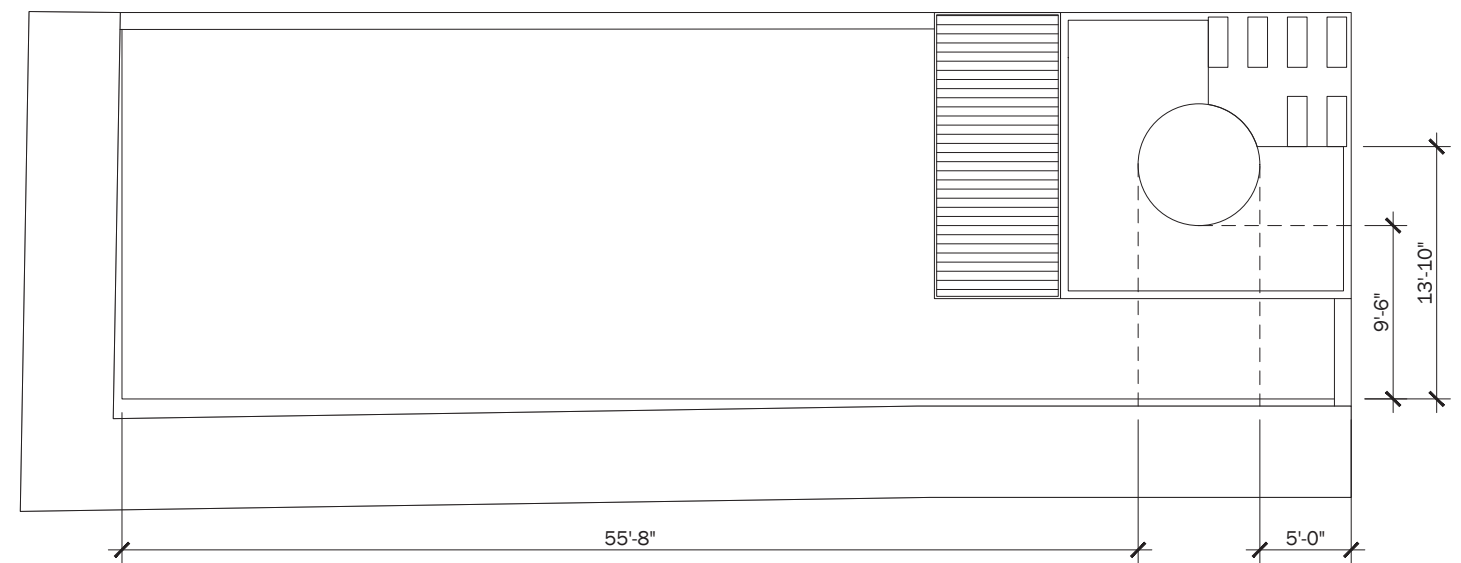

BULKHEAD PLAN

385 Greenwich – PROPOSED PLANS



**DXA studio**  
 894 6th Avenue  
 5th Floor  
 NYC 10001  
 T 212 874 0567  
 dxastudio.com

**PROJECT NUMBER** 25.59  
**DATE** April 21, 2026

Presented on 03/24/2026



385 Greenwich — **PREVIOUSLY PROPOSED DESIGN**



**DXA studio**

894 6th Avenue  
5th Floor  
NYC 10001  
T 212 874 0567

dxastudio.com

**PROJECT NUMBER** 25.59  
**DATE** April 21, 2026

**53**

Presented on 03/24/2026



385 Greenwich – PREVIOUSLY PROPOSED DESIGN



**DXA studio**

894 6th Avenue  
5th Floor  
NYC 10001  
T 212 874 0567

dxastudio.com

**PROJECT NUMBER** 25.59  
**DATE** April 21, 2026

**54**

Presented on 03/24/2026



385 Greenwich – **PREVIOUSLY PROPOSED DESIGN**



**DXA studio**

894 6th Avenue  
5th Floor  
NYC 10001  
T 212 874 0567

[dxastudio.com](http://dxastudio.com)

**PROJECT NUMBER** 25.59  
**DATE** April 21, 2026

**55**

Presented on 03/24/2026



385 Greenwich — **PREVIOUSLY PROPOSED DESIGN**



**DXA studio**

dxastudio.com

894 6th Avenue  
5th Floor  
NYC 10001  
T 212 874 0567

**PROJECT NUMBER** 25.59  
**DATE** April 21, 2026

**56**

Presented on 03/24/2026



385 Greenwich — PREVIOUSLY PROPOSED DESIGN



**DXA studio**

dxastudio.com

894 6th Avenue  
5th Floor  
NYC 10001  
T 212 874 0567

PROJECT NUMBER 25.59  
DATE April 21, 2026

**57**



1940 TAX PHOTO



PROPOSED CORNICE RESTORATION AT 385 GREENWICH



**DXA studio**

dxastudio.com

894 6th Avenue  
5th Floor  
NYC 10001  
T 212 874 0567

385 Greenwich — **PROPOSED DESIGN**

**PROJECT NUMBER** 25.59  
**DATE** April 21, 2026

**58**



1940 TAX PHOTO



PROPOSED SIGNAGE RESTORATION AT 385 GREENWICH

385 Greenwich — **PROPOSED DESIGN**



**DXA studio**

dxastudio.com

894 6th Avenue  
5th Floor  
NYC 10001  
T 212 874 0567

**PROJECT NUMBER** 25.59  
**DATE** April 21, 2026



1940 TAX PHOTO



PROPOSED 6 OVER 6 WINDOWS

385 Greenwich — **PROPOSED DESIGN**



**DXA studio**

dxastudio.com

894 6th Avenue  
5th Floor  
NYC 10001  
T 212 874 0567

**PROJECT NUMBER** 25.59  
**DATE** April 21, 2026

**60**



1940 TAX PHOTO

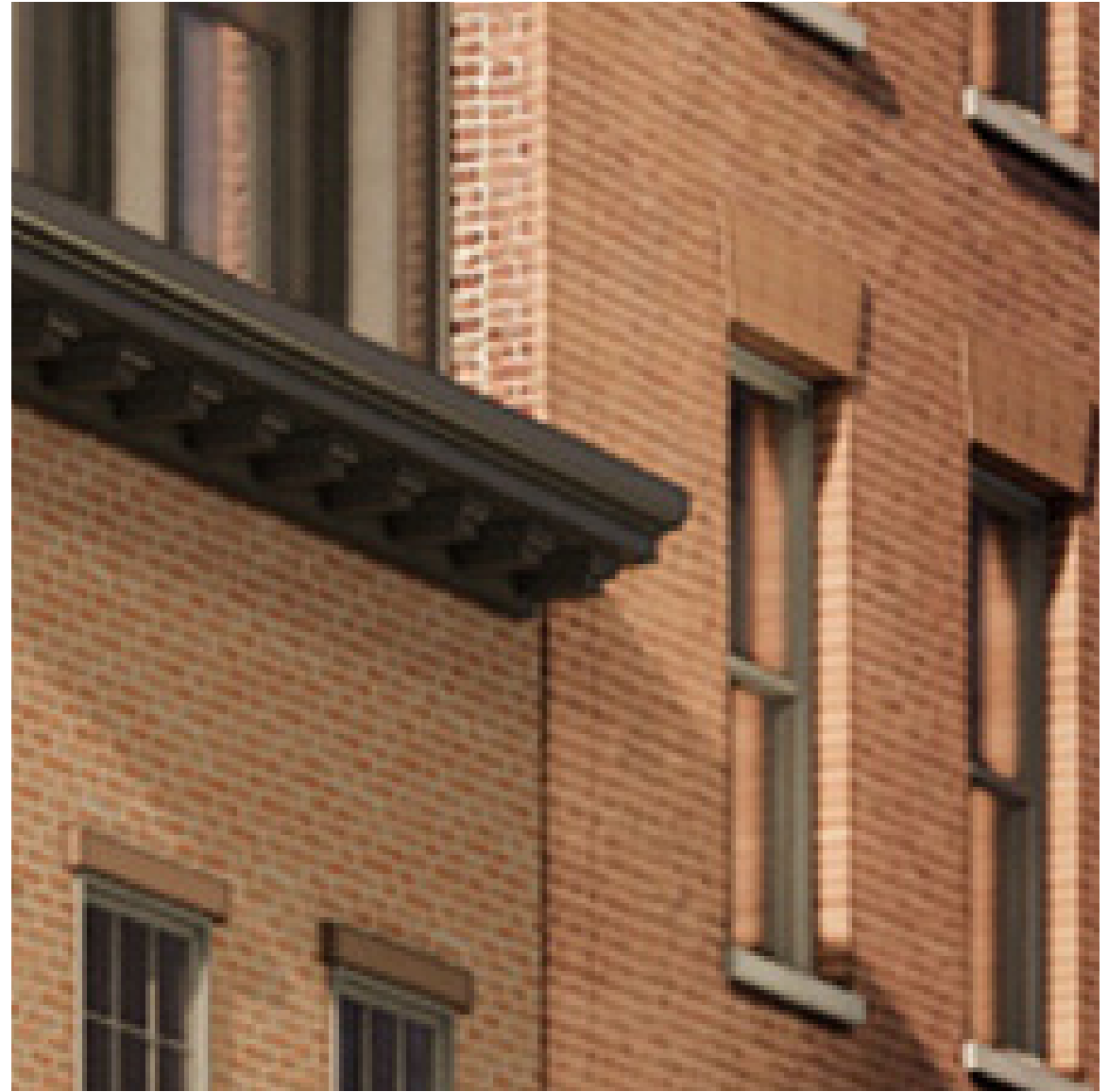

PROPOSED CORNICE RESTORATION AT 71 N MOORE



**DXA studio**

dxastudio.com

894 6th Avenue  
5th Floor  
NYC 10001  
T 212 874 0567

385 Greenwich — **PROPOSED DESIGN**

**PROJECT NUMBER** 25.59  
**DATE** April 21, 2026

**61**

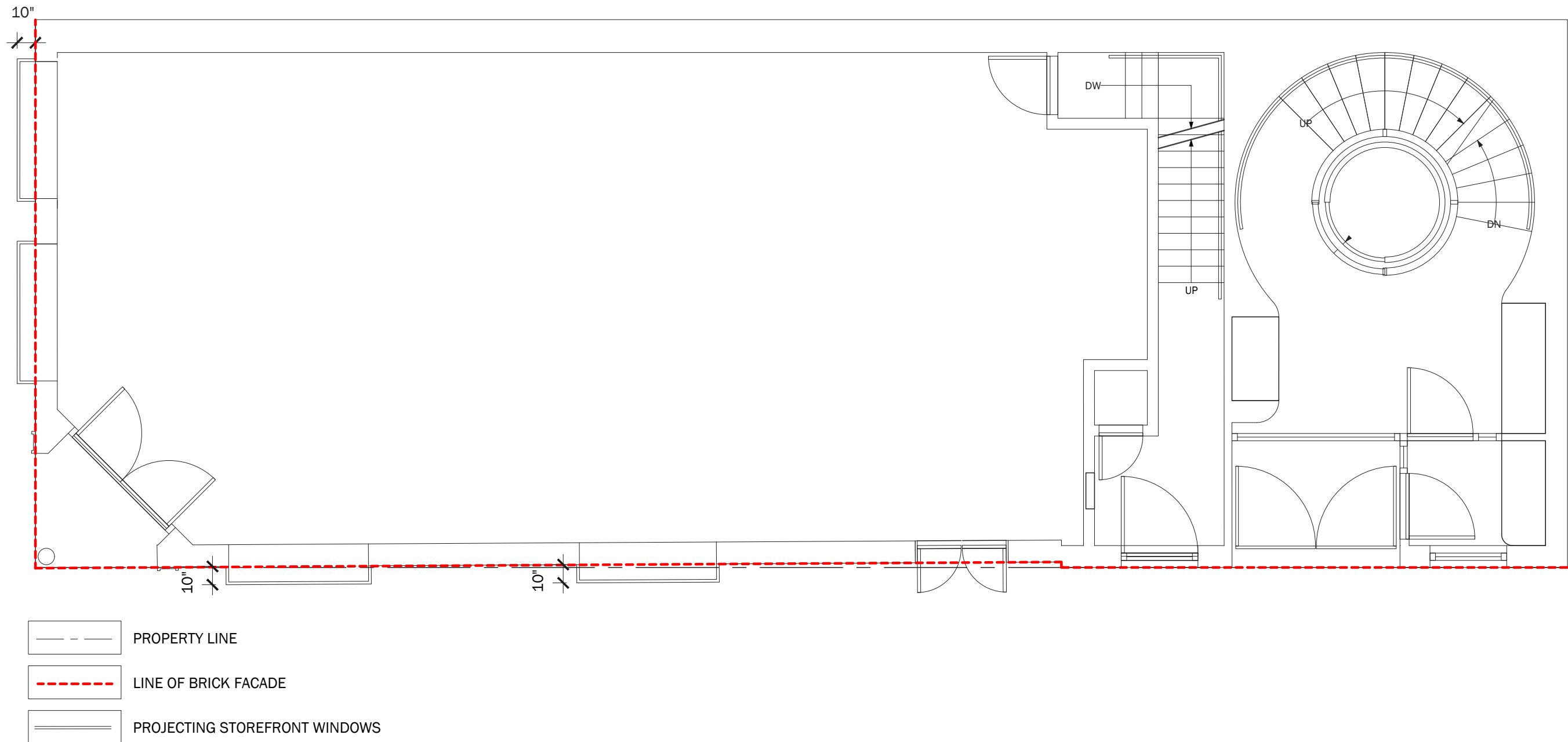

§§§ 3202.2.1.2 Architectural details.

1.2. Located 10 feet (3048 mm) or less above the sidewalk, and that project more than 4 inches (102 mm), on existing buildings or structures designated by the Landmarks Preservation Commission, may be permitted provided they do not exceed the historic projections and provided that they are approved by the Landmarks Preservation Commission, and further provided that if the projection exceeds 18 inches (457 mm), the applicant demonstrates to the Department of Transportation's satisfaction that the replacement or restoration will not adversely impact the use of the public right of way.

From the Tribeca West Historic District Designation Report

In 1898 the storefronts were replaced, and projecting show windows and an angled corner entrance were installed.



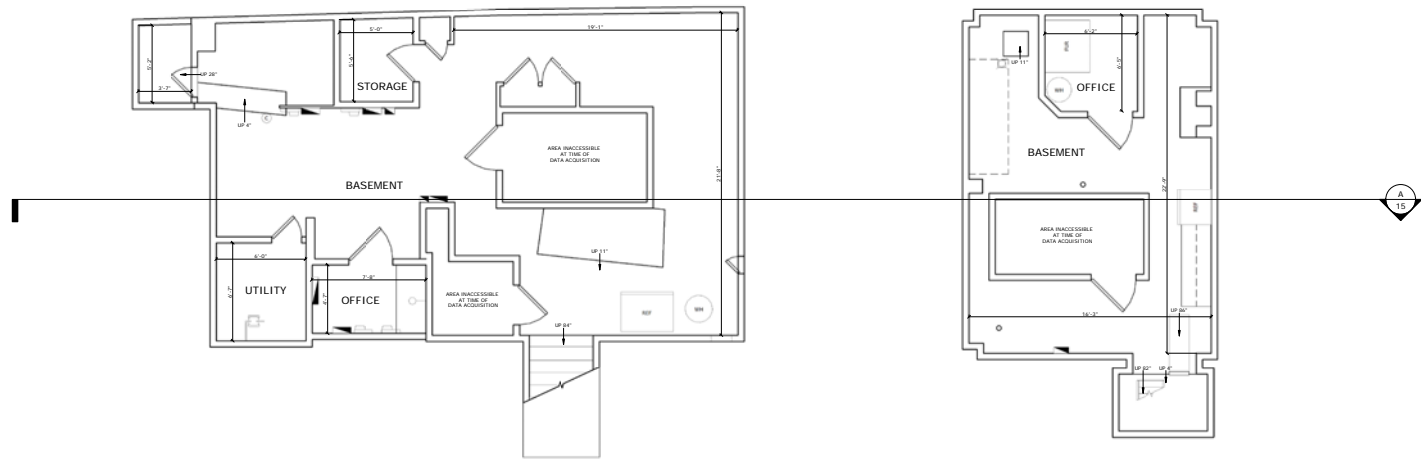

CELLAR PLAN

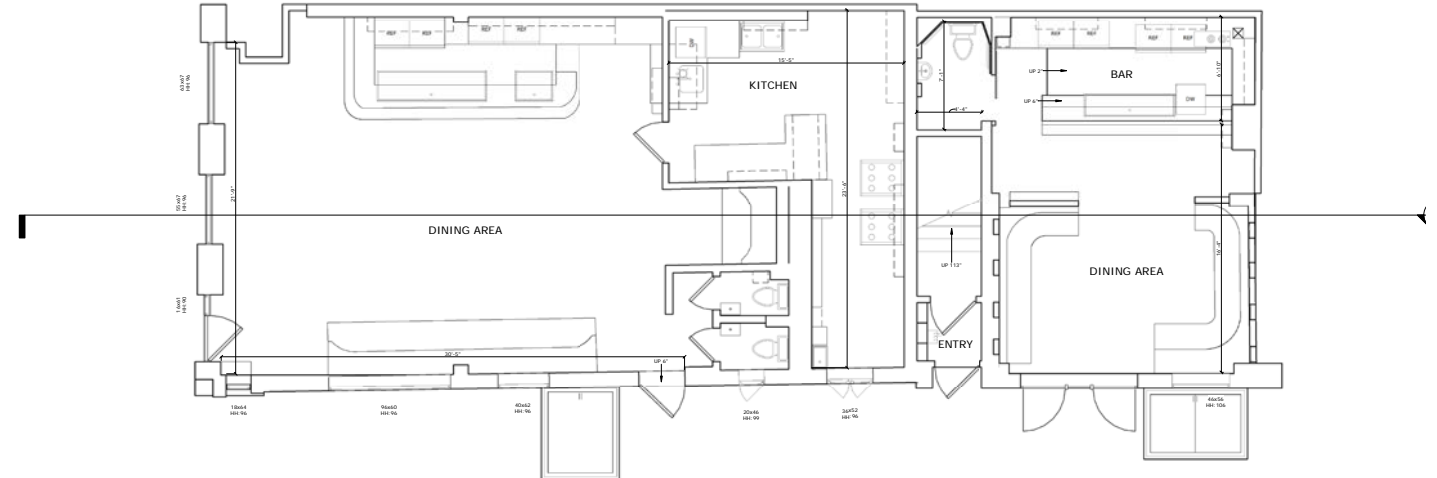

GROUND FLOOR PLAN

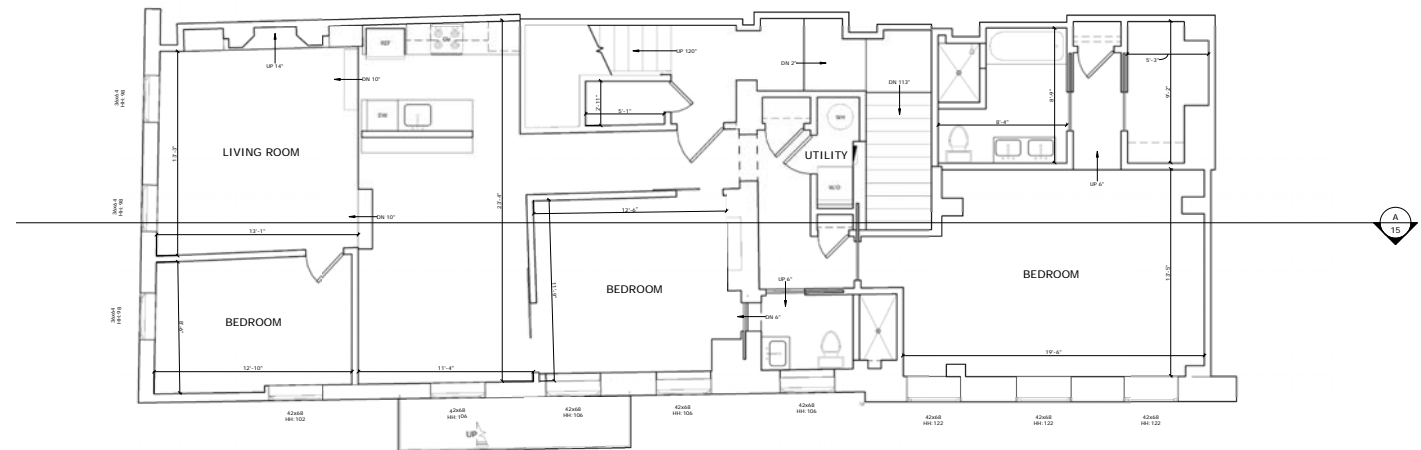

2ND FLOOR PLAN



3RD FLOOR PLAN

385 Greenwich — EXISTING PLANS



**DXA studio** 894 6th Avenue  
5th Floor  
NYC 10001  
T 212 874 0567  
dxastudio.com

**PROJECT NUMBER** 25.59  
**DATE** April 21, 2026

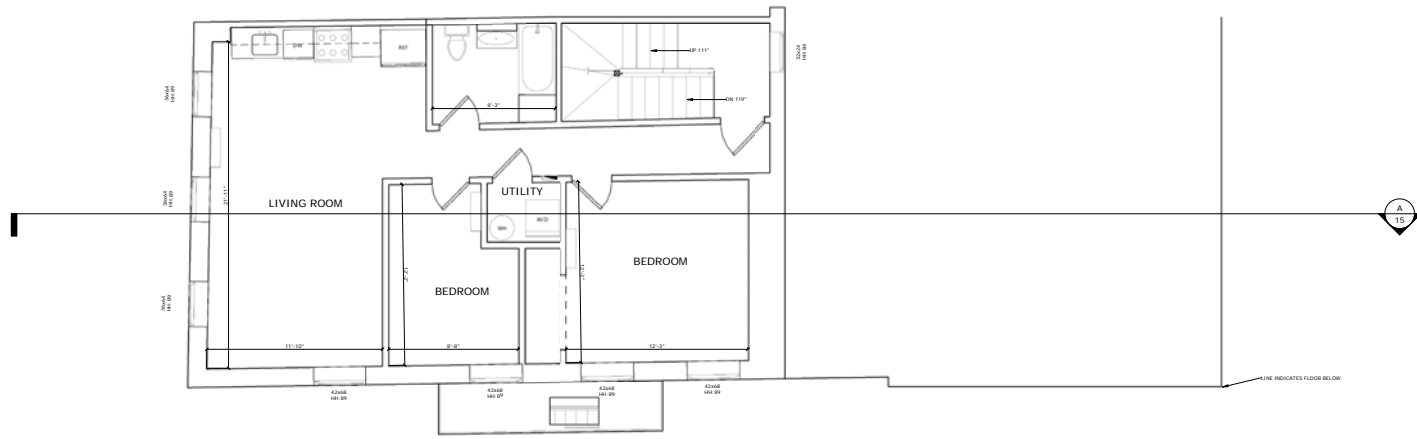

4TH FLOOR PLAN

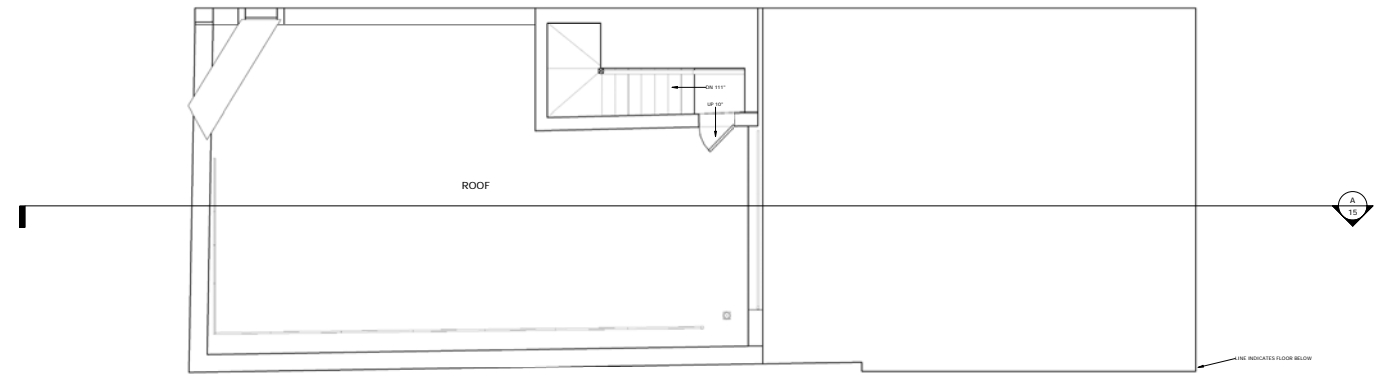

ROOF PLAN





1998 (HQ)



1998 (HQ)



**DXA studio**

dxastudio.com

894 6th Avenue  
5th Floor  
NYC 10001  
T 212 874 0567

385 Greenwich

**65**

PROJECT NUMBER 25.59  
DATE April 2022

The current proposal is:

**Preservation Department – Item 3, LPC-26-06268**

**385 Greenwich Street – Tribeca West Historic District**  
**Borough of Manhattan**

**Note: this is a Public Meeting item. No public testimony will be received today as the hearing on this item is closed.**