

The current proposal is:

Preservation Department – Item 1, LPC-25-09964

**Orchard Beach Pavilion – Orchard Beach Bathhouse – Individual  
Landmark  
Borough of Bronx**

**Note: this is a Public Meeting item. No public testimony will be received today as the hearing on this item is closed.**

# ORCHARD BEACH PAVILION RECONSTRUCTION

## LPC PUBLIC MEETING | REPLACEMENT WINDOWS

AUGUST 12, 2025



NYC Parks

NYC / EDC

MARVEL

# Design Team



**NYC / EDC**

**MARVEL**



**ARUP**



**MARVEL**  
**NYC / EDC**

Orchard Beach Pavilion | LPC Public Meeting: Replacement Windows

# Project Overview - Site Aerial



**MARVEL**  
**NYC/EDC**

**Orchard Beach Pavilion | LPC Public Meeting: Replacement Windows**

# Project Overview - Location and Scope



The Bronx

2 MI



Pelham Bay Park

1000 FT

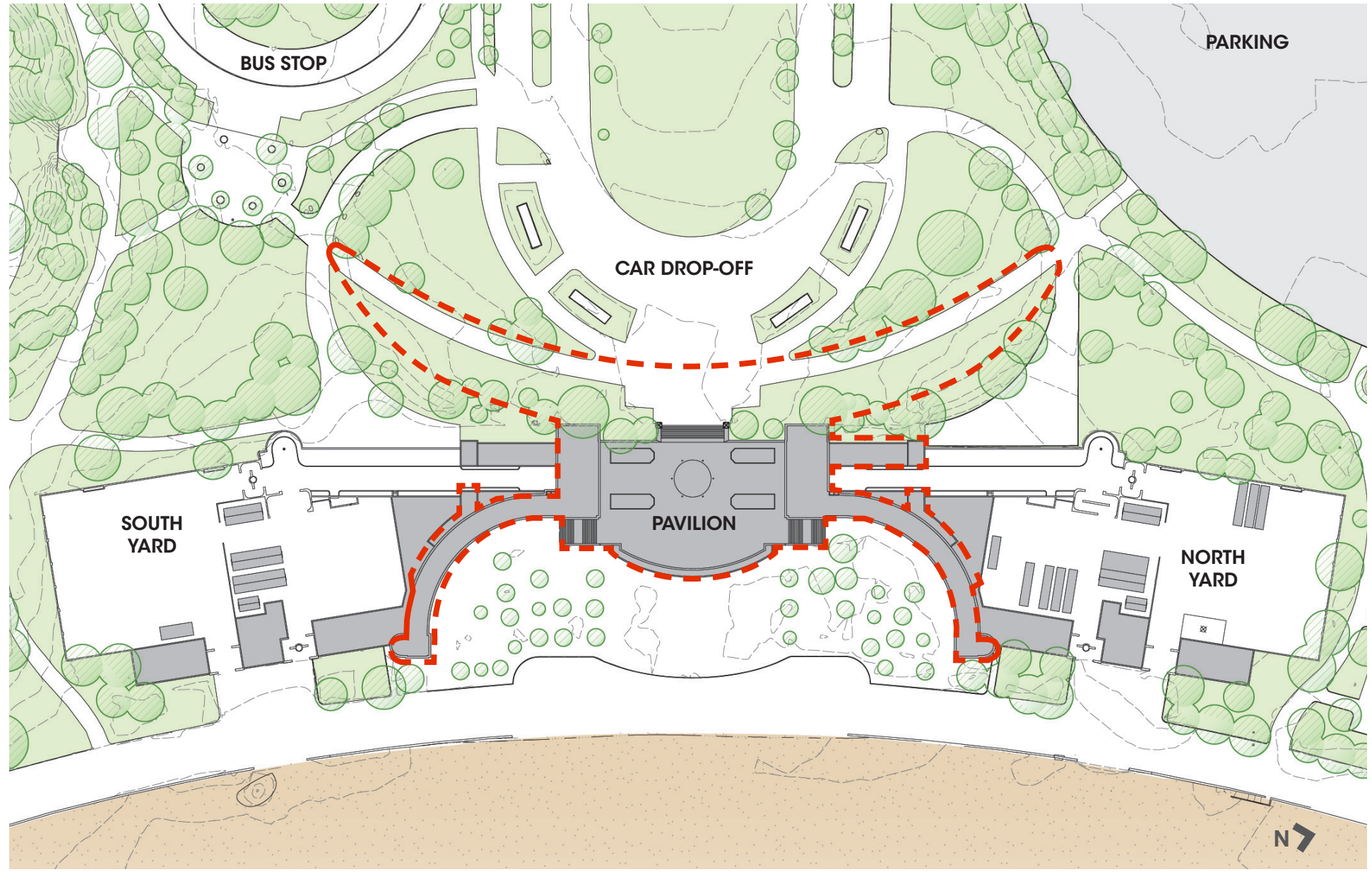

Orchard Beach with Scope Line

200 FT



**MARVEL**  
**NYCEDC**

Orchard Beach Pavilion | LPC Presentation

NYC Parks

# Project Overview - Building History

- Parks Commissioner: Robert Moses  
Consulting Architect: Aymar Embury II  
Park Engineer: William H. Latham
- South Changing Yard - opened Summer 1936  
Full Pavilion - opened Summer 1937
- Received LPC landmark designation in 2006
- Eligible for the National Register of Historic Places due to its location in the Pelham Bay Park Historic District

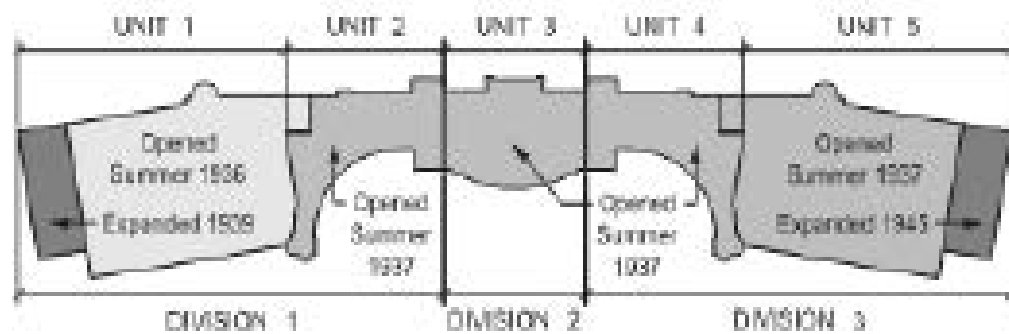

*View of the Upper and Lower Promenades, Cafeteria, and South Loggia, Looking South (July 18, 1936, DPR Image #12206)*



# Project Overview - Objectives

1

## RESTORE THE PAVILION

- Restore the ARCHITECTURE
- Restore CIRCULATION
- Allow people to experience the restoration

2

## PROVIDE ACCESS

- Provide equitable and maintainable ADA access between:
- The land side and the beach
  - The Upper Level and the Lower Level

3

## PROVIDE VIABLE SPACES

- Provide concessions & rentable space
- Provide appropriate community space
- Allow for flexibility & longevity
- Limit vulnerable construction in the flood plain



NYC Parks

MARVEL  
NYCEDC

Orchard Beach Pavilion | LPC Presentation

# Construction Progress - Site Photos



Before



Present



**MARVEL**  
**NYC/EDC**

Orchard Beach Pavilion | LPC Public Meeting: Replacement Windows

NYC Parks



# Construction Progress - Site Photos



Before



Present



**MARVEL**  
**NYC/EDC**

Orchard Beach Pavilion | LPC Public Meeting: Replacement Windows

NYC Parks

# Construction Progress - Site Photos



Before



Present



**MARVEL**  
**NYC/EDC**

Orchard Beach Pavilion | LPC Public Meeting: Replacement Windows

# Project Overview - Programming

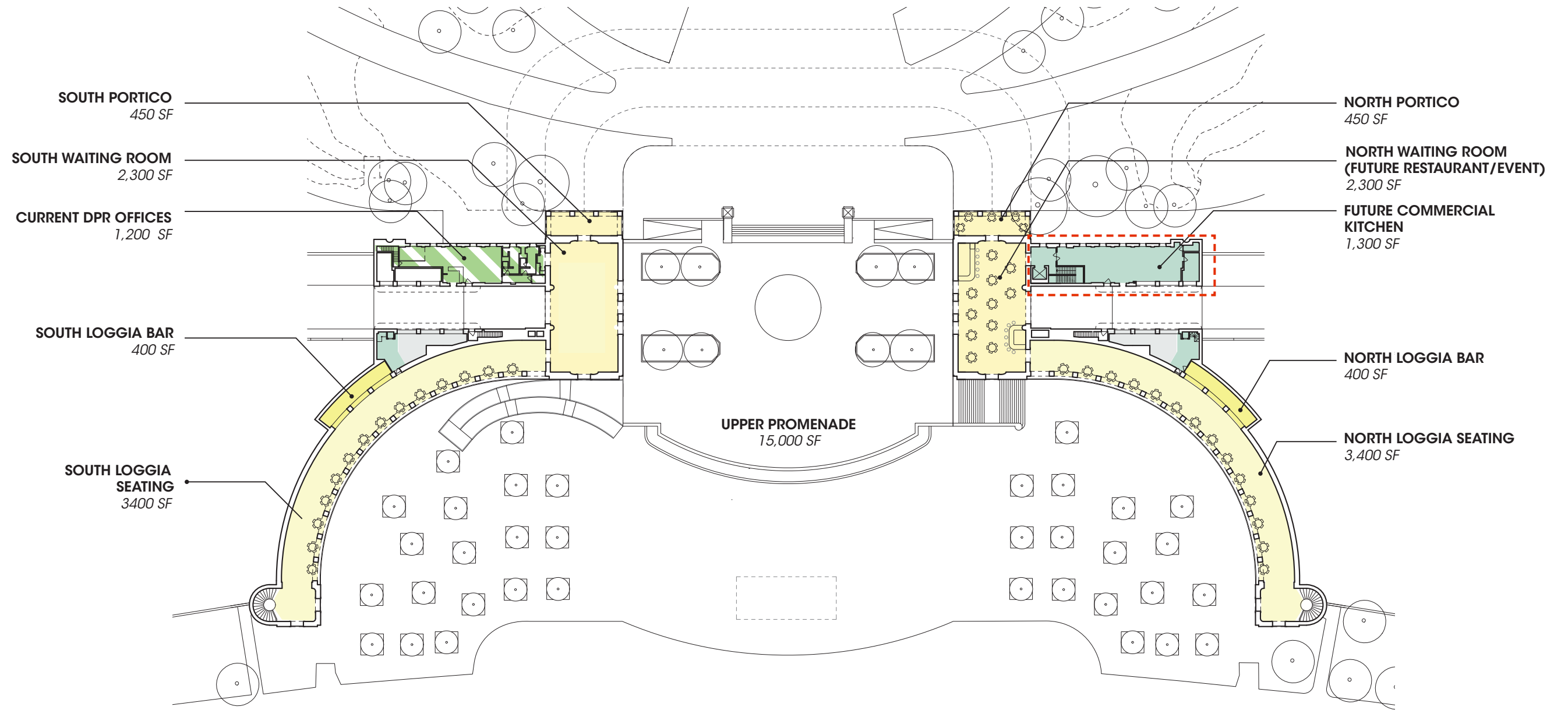

**LEGEND**

PARKS

SEATING

CONCESSIONS

BACK OF HOUSE



**MARVEL  
NYCEDC**

**Orchard Beach Pavilion | LPC Presentation**

# Replacement Windows - Facade Location and Approaches

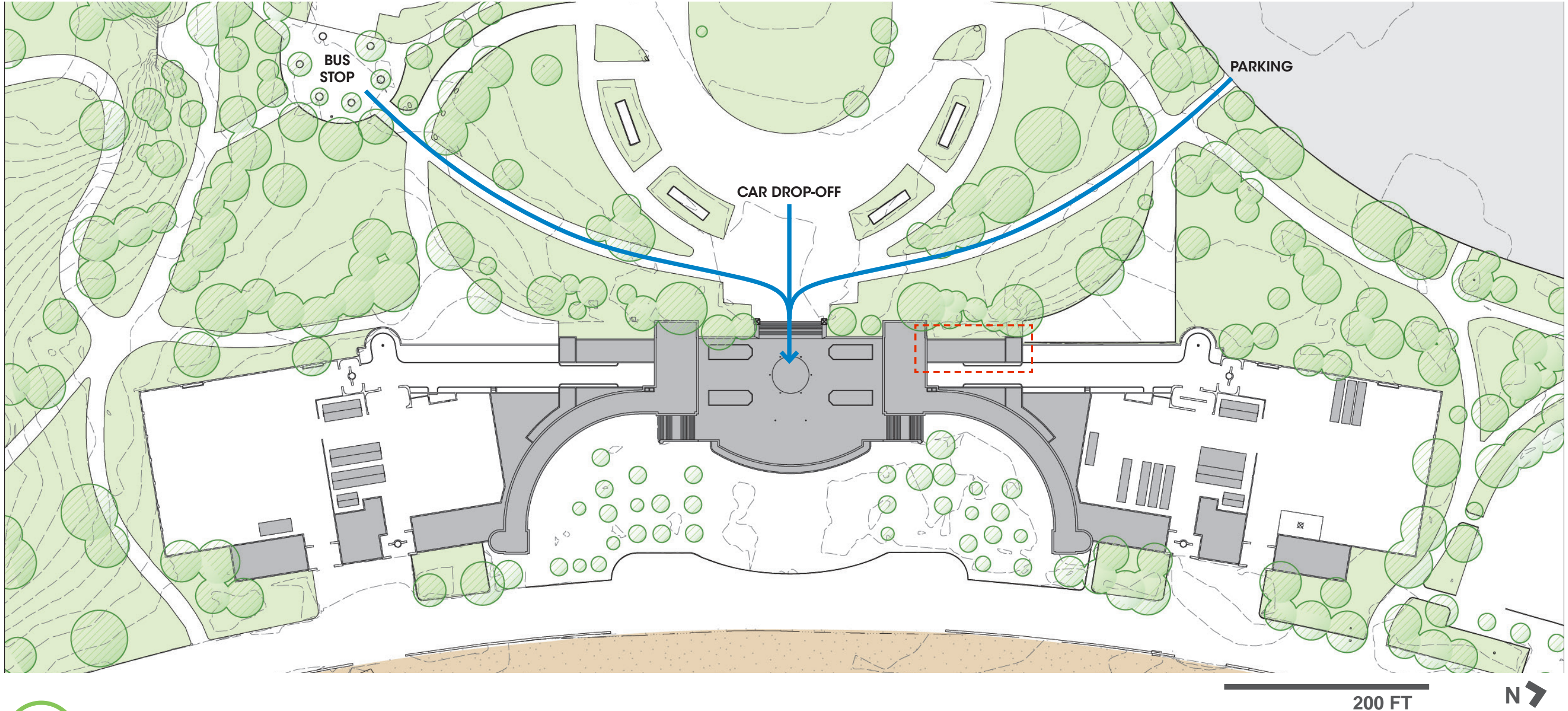

**MARVEL**  
NYC/EDC

Orchard Beach Pavilion | LPC Public Meeting: Replacement Windows

NYC Parks

# Replacement Windows - Facade Visibility

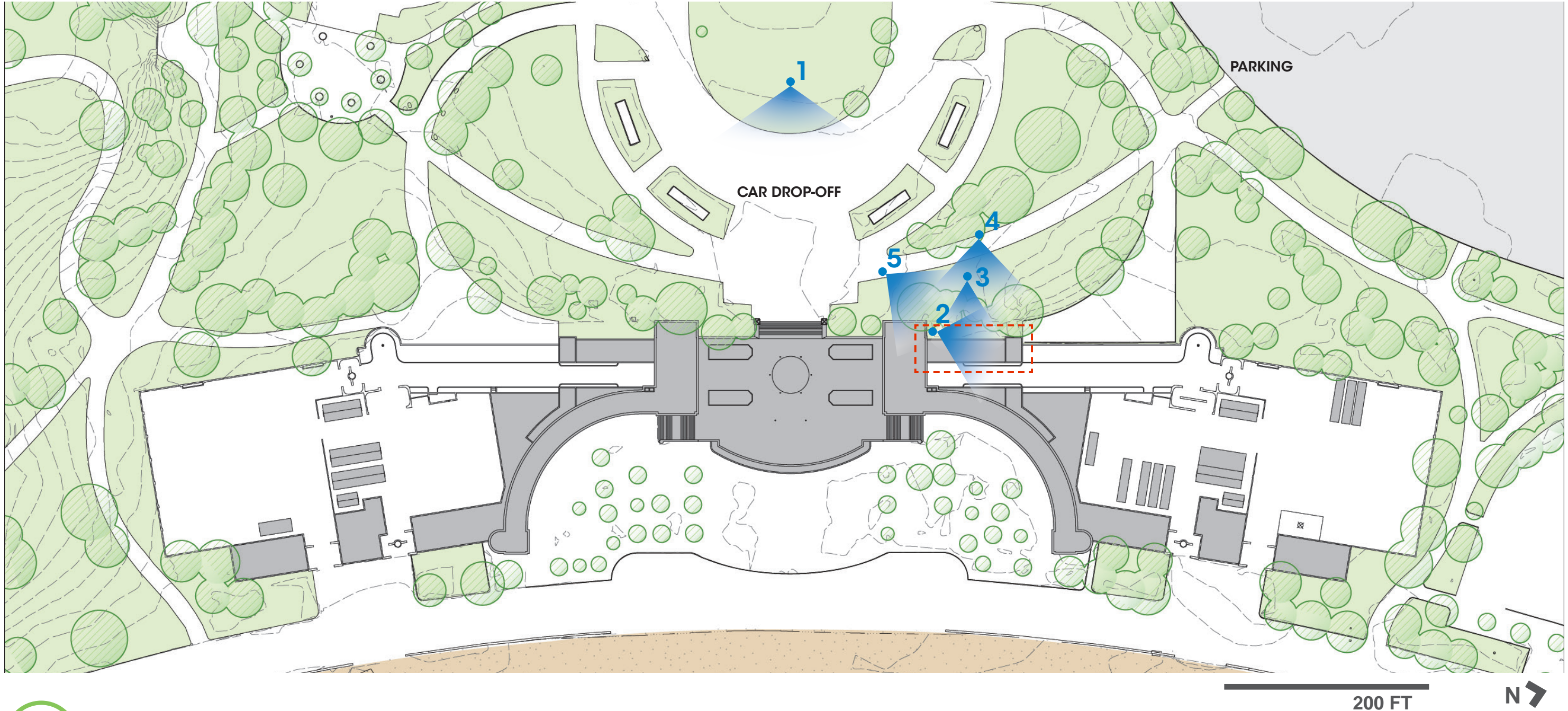

**MARVEL**  
NYC/EDC

Orchard Beach Pavilion | LPC Public Meeting: Replacement Windows

NYC Parks

# Replacement Windows - Facade Visibility



View 1



NYC Parks

**MARVEL**  
**NYC/EDC**

Orchard Beach Pavilion | LPC Public Meeting: Replacement Windows

# Replacement Windows - Facade Visibility



View 2



View 3



**MARVEL**  
**NYC/EDC**

Orchard Beach Pavilion | LPC Public Meeting: Replacement Windows

# Replacement Windows - Facade Visibility



View 4



View 5



NYC Parks

**MARVEL**  
**NYC/EDC**

Orchard Beach Pavilion | LPC Public Meeting: Replacement Windows



# Replacement Windows - Existing Conditions - North Wing

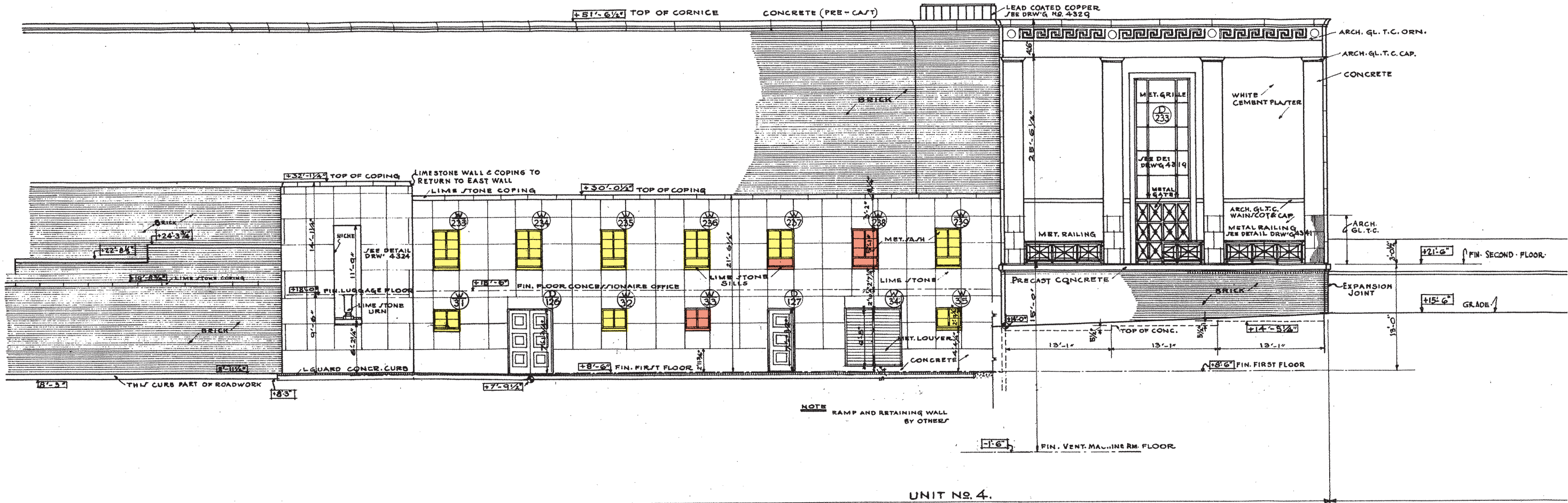

WEST-ELEVATION.

- Historic Window
- Plywood



**MARVEL**  
NYC/EDC

Orchard Beach Pavilion | LPC Public Meeting: Replacement Windows

# Replacement Windows - Existing Conditions



**MARVEL**  
**NYC/EDC**

Orchard Beach Pavilion | LPC Public Meeting: Replacement Windows

# Replacement Windows - Existing Conditions - South Wing

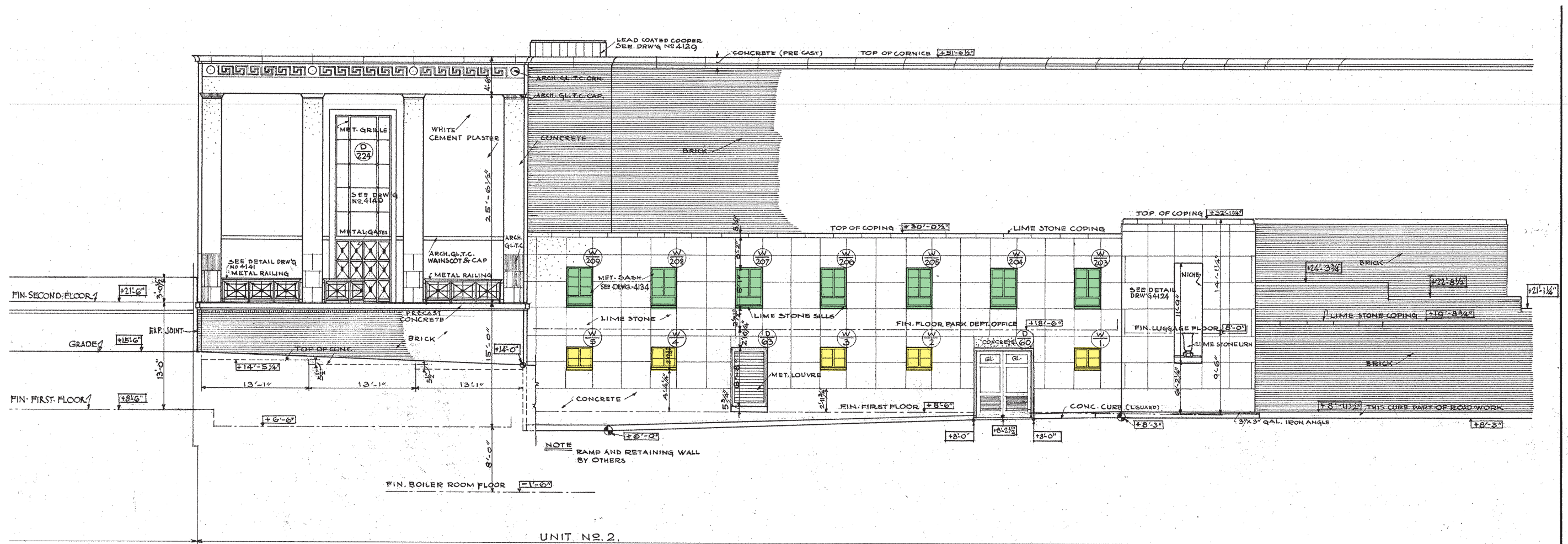

WEST - ELEVATION.

- Historic Window
- Double-Hung Replacement Window

# Replacement Windows - Existing Conditions - South Wing

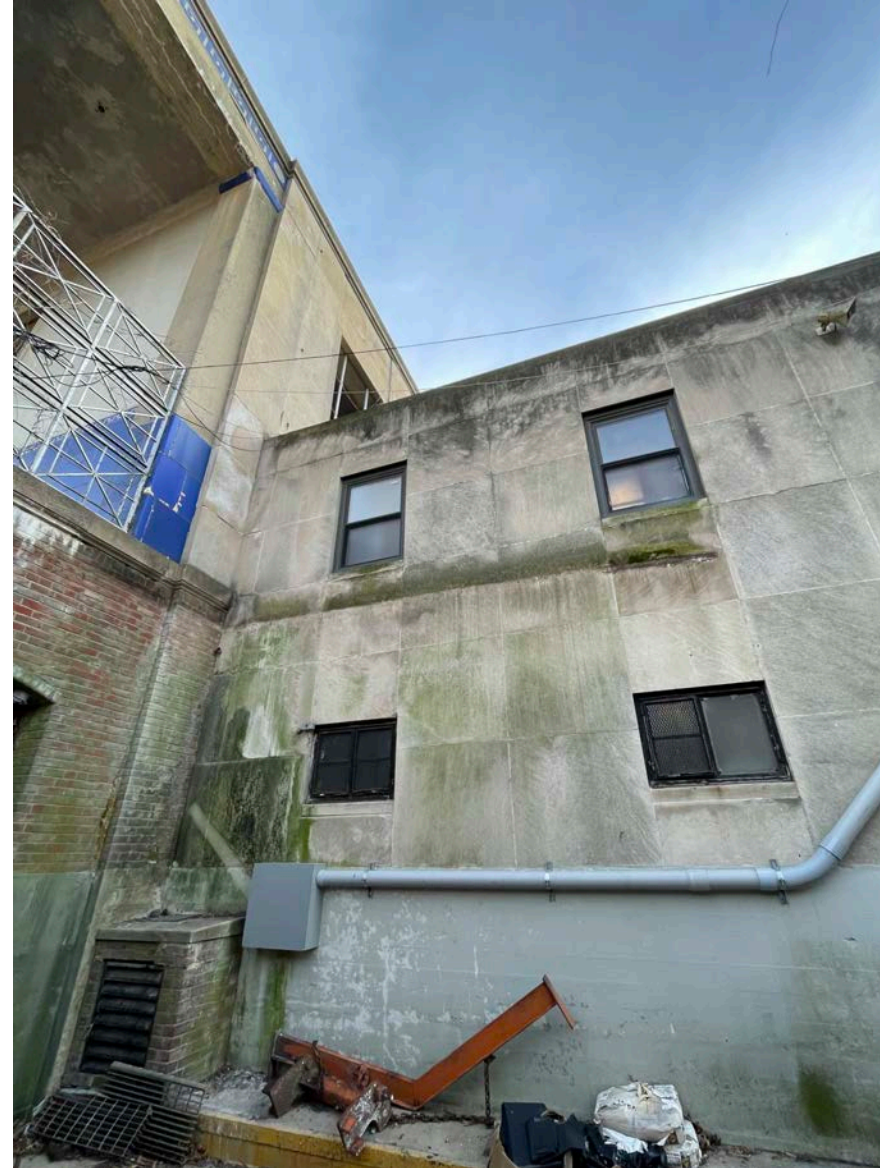

**MARVEL**  
**NYC/EDC**

**Orchard Beach Pavilion | LPC Public Meeting: Replacement Windows**

# Replacement Windows - Proposed Windows

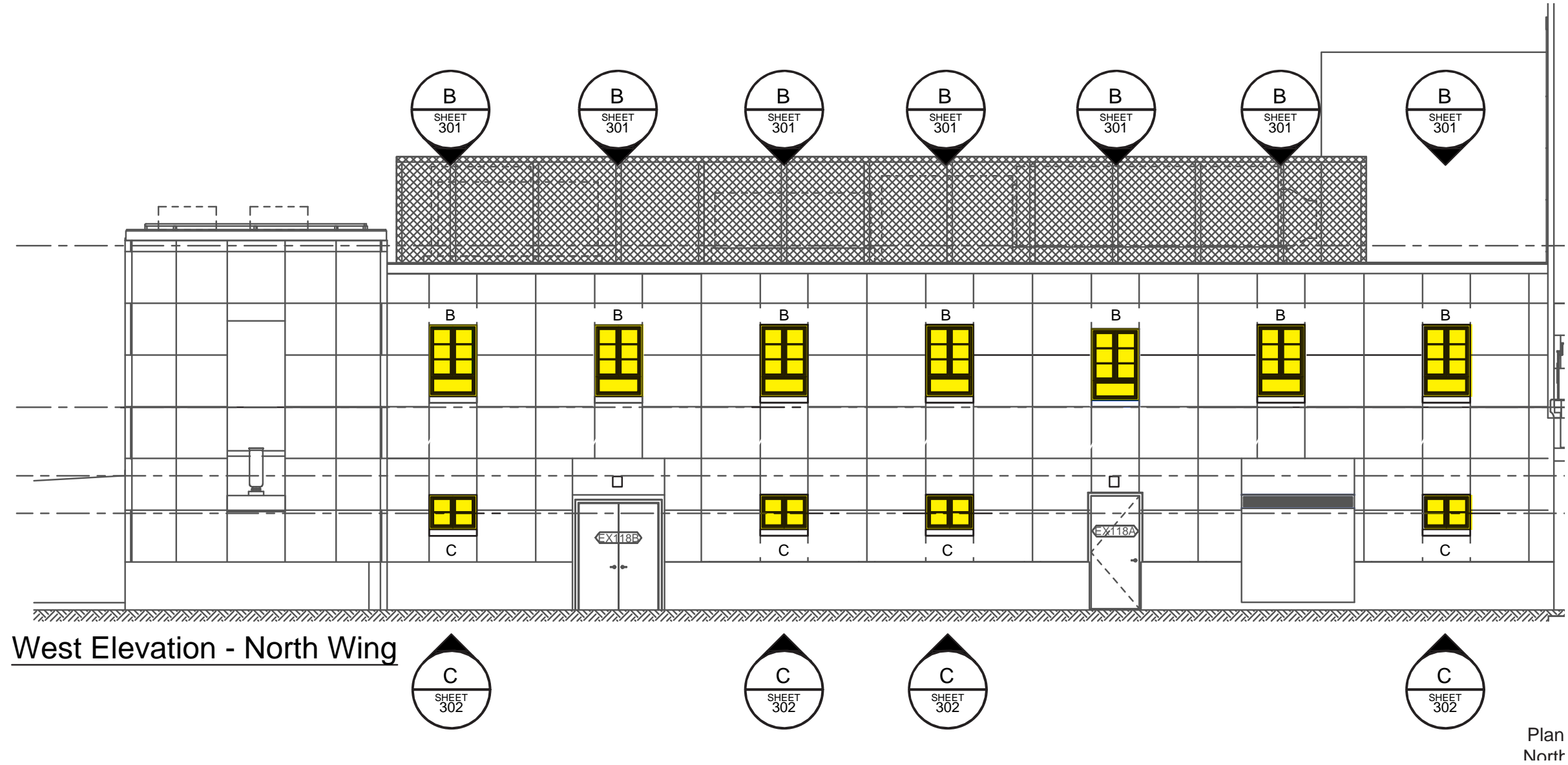

West Elevation - North Wing



MARVEL  
NYC/EDC

Orchard Beach Pavilion | LPC Public Meeting: Replacement Windows

# Replacement Windows - Historic vs Proposed Elevations

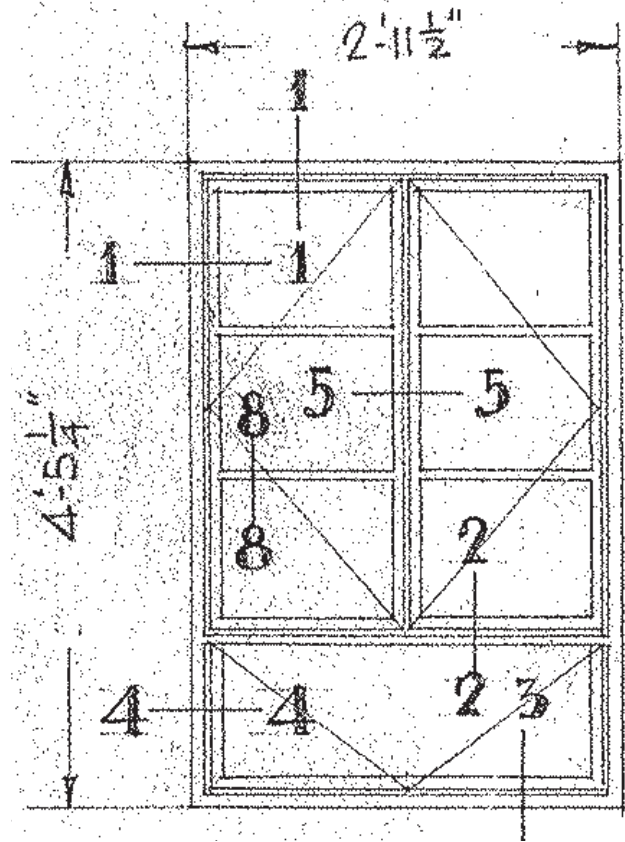

Historic Elevation: Type B  
2nd Flr Windows

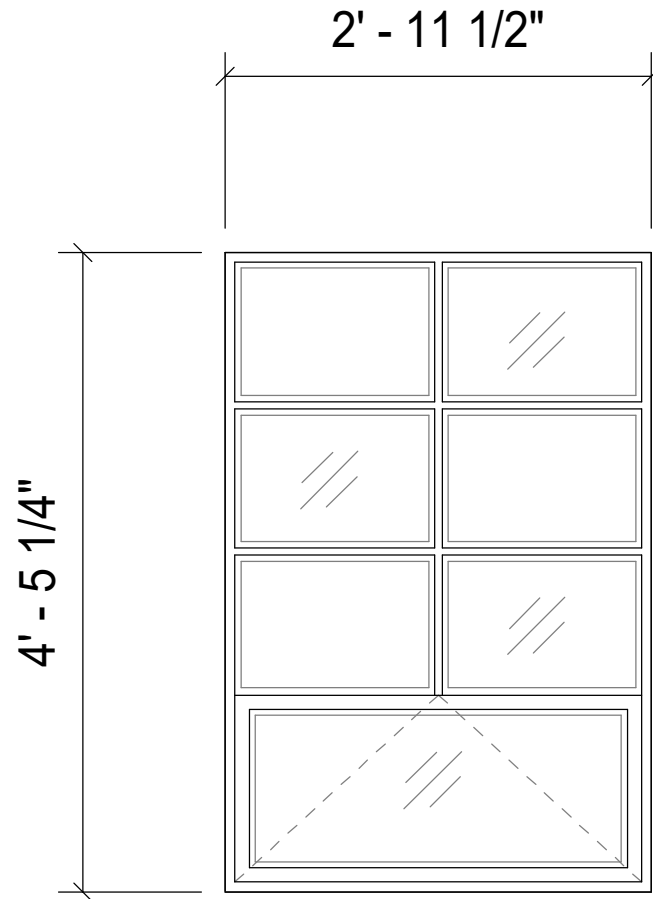

Proposed Elevation: Type B  
2nd Flr Windows

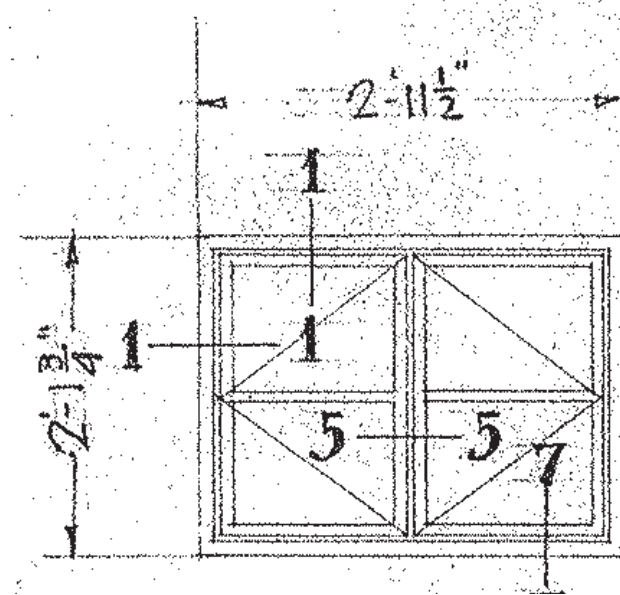

Historic Elevation: Type C  
1st Flr Windows

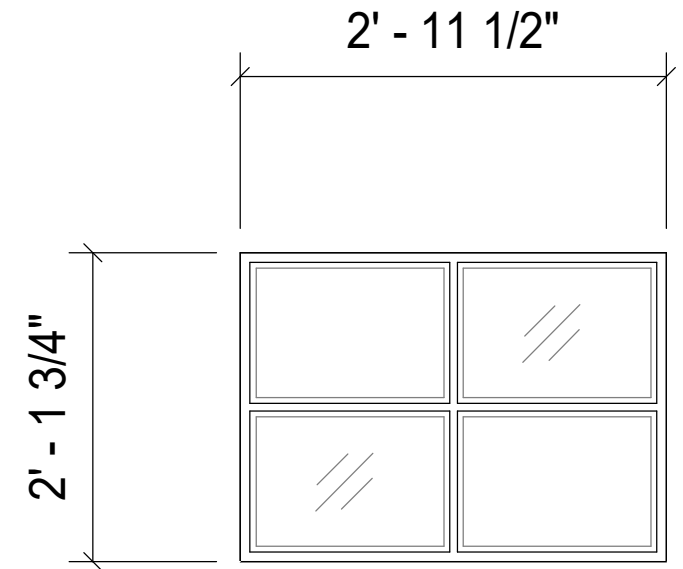

Proposed Elevation: Type C  
1st Flr Windows



MARVEL  
NYC/EDC

Orchard Beach Pavilion | LPC Public Meeting: Replacement Windows

# Replacement Windows - Head and Sill Details

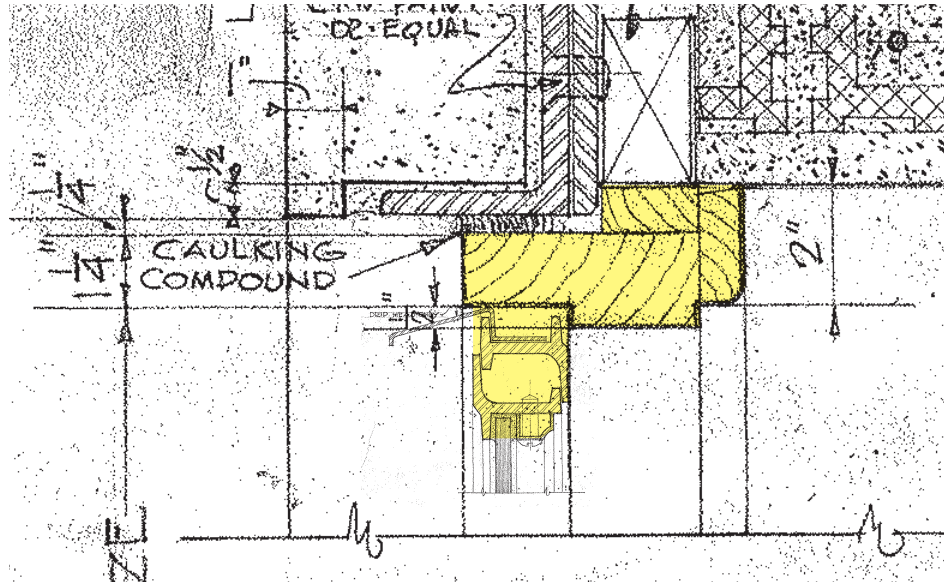

Historic Head and Sill Details

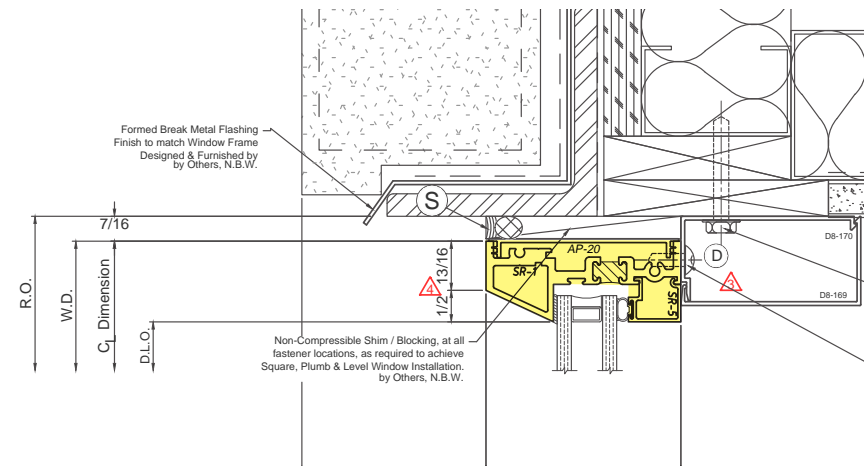

Proposed Fixed Head and Sill Details

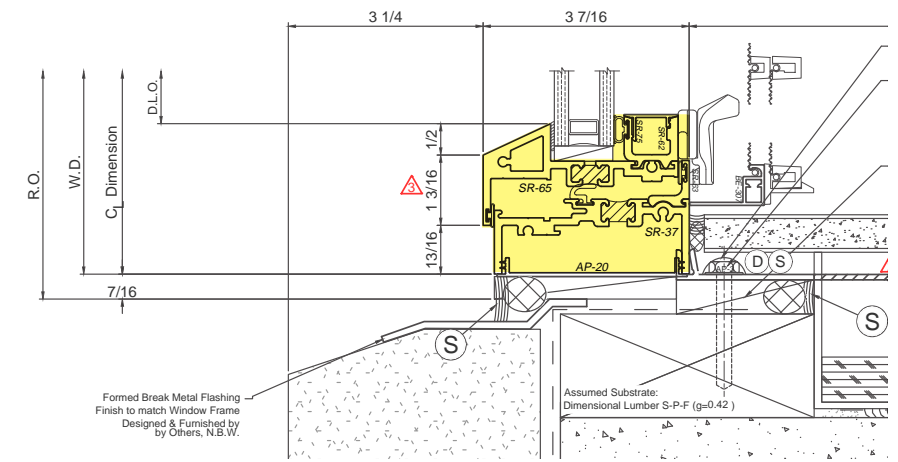
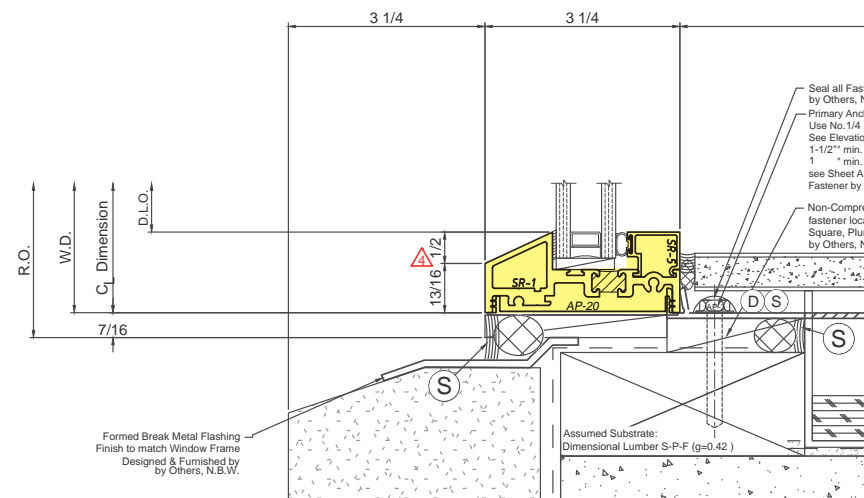
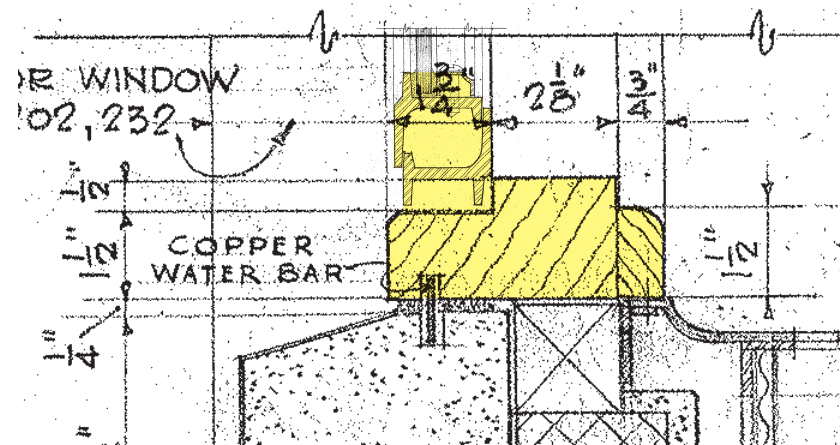

Proposed Operable Sill Detail



**MARVEL**  
NYC/EDC

Orchard Beach Pavilion | LPC Public Meeting: Replacement Windows

# Replacement Windows - Jamb and Vertical Rail Details

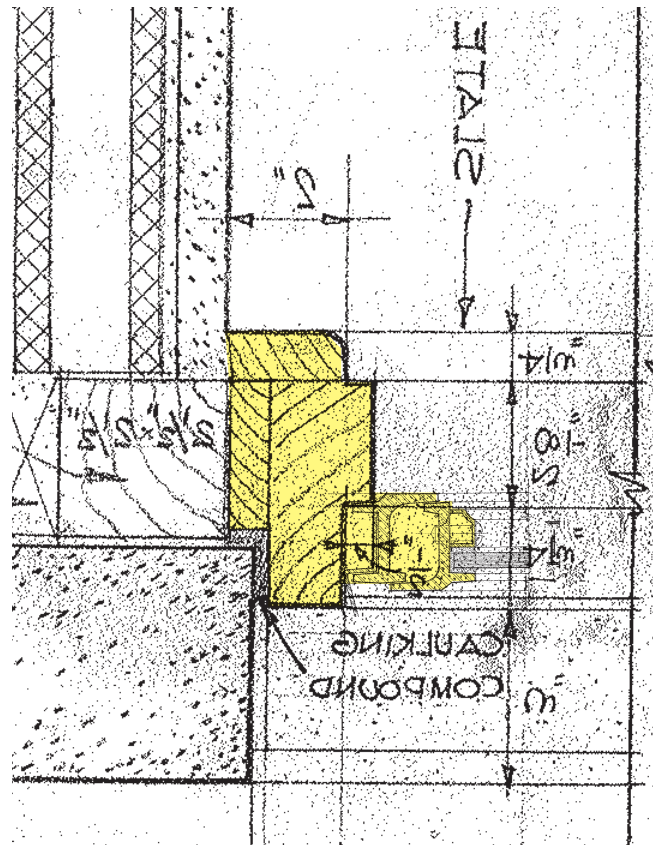

Historic Jamb Detail

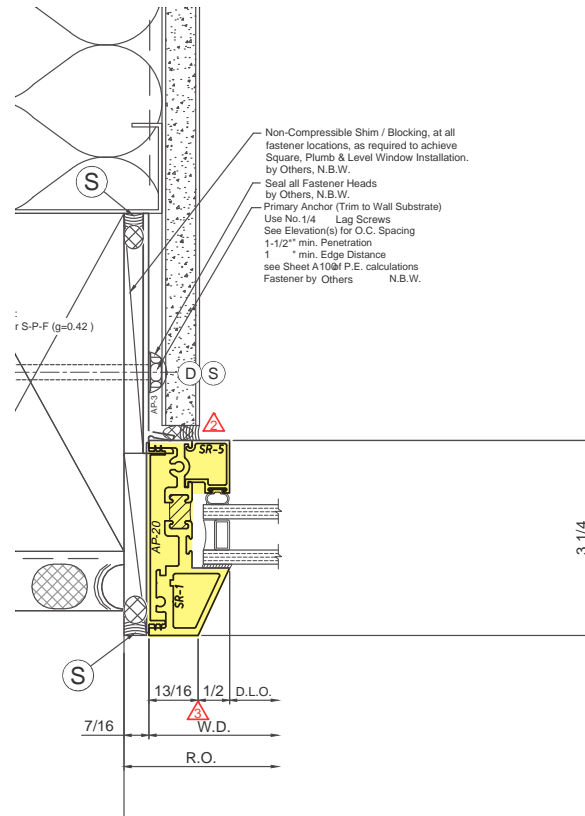

Proposed Fixed Jamb Detail

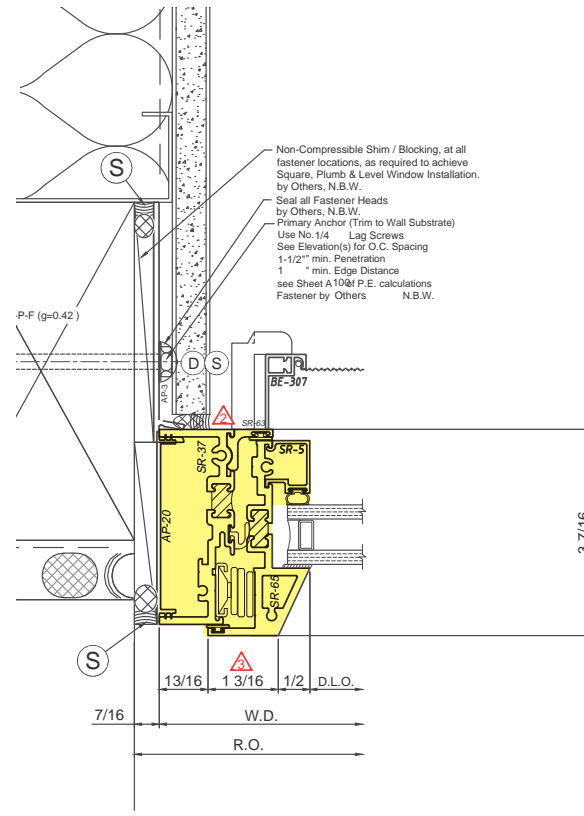

Proposed Operable Jamb Detail

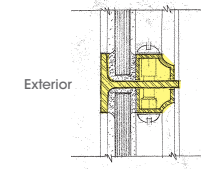

Historic Fixed Horizontal Rail Detail

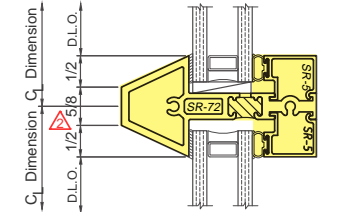

Proposed Fixed Horizontal Rail Detail

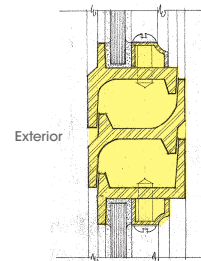

Historic Operable Horizontal Rail Detail

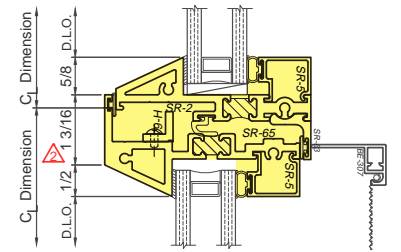

Proposed Operable Horizontal Rail Detail

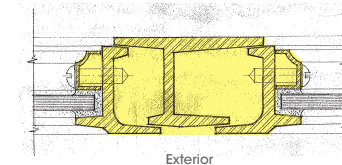

Historic Operable Vertical Rail Detail

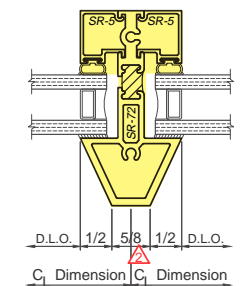

Proposed Fixed Vertical Rail Detail



**MARVEL**  
NYC/EDC

Orchard Beach Pavilion | LPC Public Meeting: Replacement Windows



# Replacement Windows - Historic vs Proposed Elevations

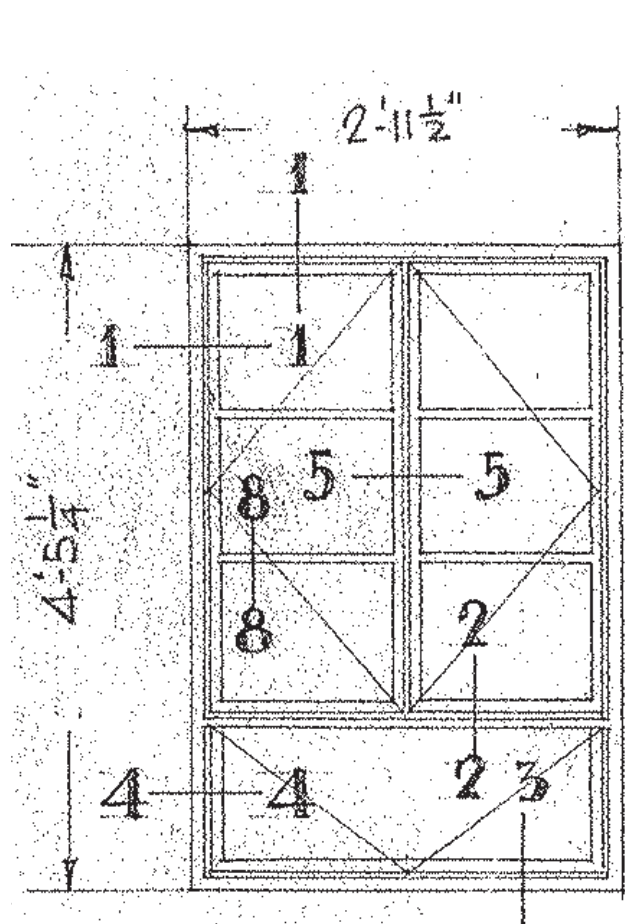

Historic Elevation: Type B  
2nd Flr Windows

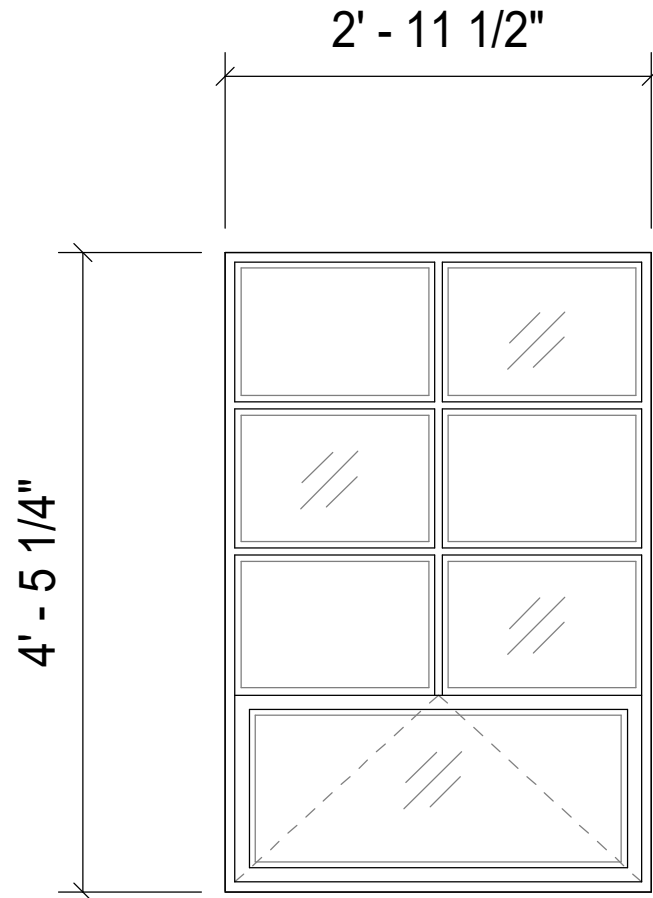

Proposed Elevation: Type B  
2nd Flr Windows

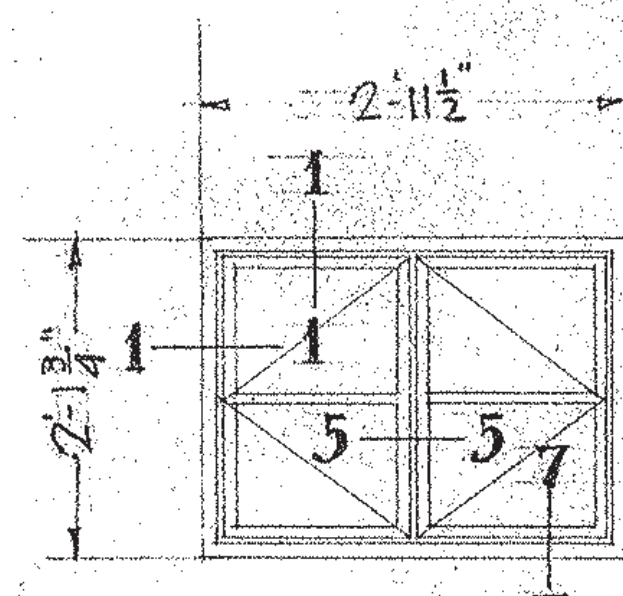

Historic Elevation: Type C  
1st Flr Windows

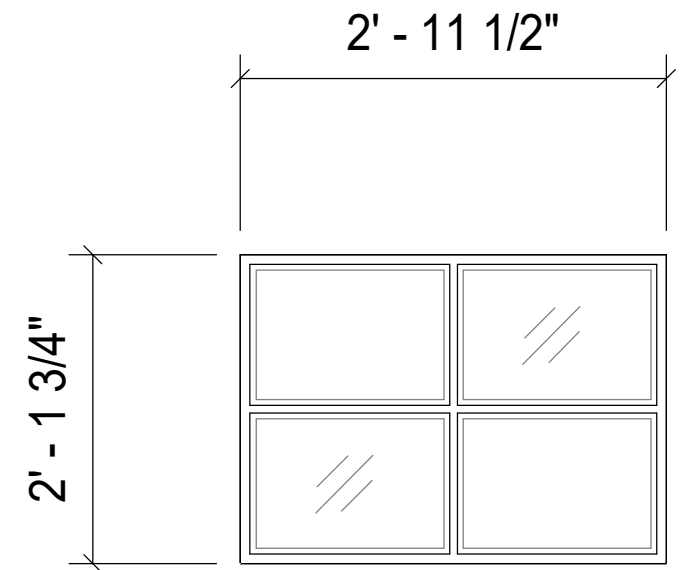

Proposed Elevation: Type C  
1st Flr Windows



**MARVEL**  
NYC/EDC

Orchard Beach Pavilion | LPC Public Meeting: Replacement Windows



**MARVEL**  
**NYC/EDC**

**Orchard Beach Pavilion | LPC Public Meeting: Replacement Windows**

The current proposal is:

Preservation Department – Item 1, LPC-25-09964

**Orchard Beach Pavilion – Orchard Beach Bathhouse – Individual  
Landmark  
Borough of Bronx**

**Note: this is a Public Meeting item. No public testimony will be received today as the hearing on this item is closed.**