

**July 18, 2023**  
Public Hearing

The current proposal is:

**Preservation Department – Item 4, LPC-23-08522**

**123 West 43rd Street – The Town Hall – Individual and  
Interior Landmark  
Borough of Manhattan**

To testify virtually, please join Zoom

**Webinar ID:** 864 9888 2944

**Passcode:** 903125

By Phone: 1 646-558-8656 US (New  
York) 877-853-5257 (Toll free) US  
888 475 4499 (Toll free)

**Note:** If you want to testify virtually on an item, join the Zoom webinar at the agenda's "Be Here by" time (about an hour in advance). When the Chair indicates it's time to testify, "raise your hand" via the Zoom app if you want to speak (\*9 on the phone). Those who signed up in advance will be called first.



**07/18 MEETING PRESENTATION**  
**DIGITAL POSTER DISPLAYS PROPOSAL**  
**LPC-23-08522**  
**123 WEST 43RD STREET**

## Project Description

Decades ago, The Town Hall was adorned with six large, decorative poster boxes. Alas, they are long gone. We aim to recreate those display boxes with a historically faithful design, with one exception: the boxes will contain digital displays built to withstand the rigors of outdoor exposure – extreme heat, cold, rain, etc.

The displays will sit behind a cover of protective acrylic and locked inside tamper-proof display boxes securely affixed to in the exact same spot where the previous boxes appeared.

The Times Square BID estimates 80,000 people per day pass the intersection to our west. Town Hall wants to take advantage of that foot traffic by attracting audiences to more shows. We are perhaps the only venue of our size in the theater district *without* illuminated signage.

Digital displays will allow us to program content that changes every 20 seconds, whether it celebrates our history or our upcoming events. They can work individually or in sync. We will not use any sound, only images.

Not only are the new display boxes more attractive than the 13 small aluminum boxes that currently reside there, but they will reduce printing costs and be update themselves any time of the day or night.

There are no hotels on our block nor anyone residing directly across the street, so no one will be disturbed by the illumination which is not extremely bright. Unless CB5 objects, we would like them to operate around the clock.

This project will help The Town Hall stand out and compete in a crowded environment. Too many people walk by us every day and don't even notice they are passing one of the jewels in NYC's cultural crown.

## Background

The Town Hall is a 1500-seat nonprofit national historic landmark venue in the heart of Times Square. Built by suffragists in 1921, the hall has hosted countless musical and cultural milestones.

A stepping-stone for diverse artists who went on to become legends, many people of color who were denied access to other stages found a home here at The Town Hall. The founders called it “the hall for all,” and that credo remains true today.

Designed by McKim, Mead, and White, the auditorium is known for its superior acoustics and the fantastic sightlines, reportedly giving rise to the phrase, “not a bad seat in the house.”

Richard Strauss and Isaac Stern made their US debuts at Town Hall. Marian Anderson gave her first New York recital here. Dizzy Gillespie and Charlie Parker debuted bebop to the world at Town Hall. Margaret Sanger was arrested for daring to speak to men and women about birth control.

Bob Dylan performed his first major concert at Town Hall. America's Town Meeting of the Air (a radio program broadcast from 1935-1955) one of the most influential public discussion shows of the twentieth century, featured guests as diverse as Eleanor Roosevelt, Langston Hughes, Richard Nixon, and Jackie Robinson.

Town Hall continues to be a forum for expression, education and exploration. In recent history, Town Hall welcomed Gilberto Gil, Joan Baez, Stephen Colbert, Jack White, Patti Smith, Larry David, Tig Notaro, Garrison Keillor, Ray LaMontagne, Ira Glass, and Neil deGrasse Tyson.

Town Hall also welcomes thousands of public-school children every year who participate in Town Hall Arts in Education programs in the auditorium.

## PROJECT DESCRIPTION



ADDRESS   
 W  RD St   
 N  Y  r  , NY   
 BLOCK   
 LOT   
 ONING MAP   D  
 ONING DISTRICT  C       
 CONST. CLASS  , FIREPROOF



**PROJECT LOCATION**

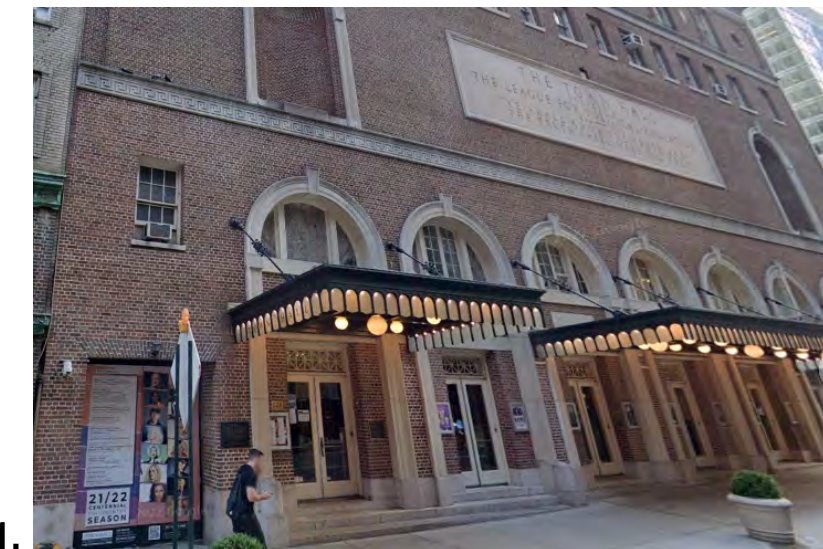

### PROJECT LOCATION

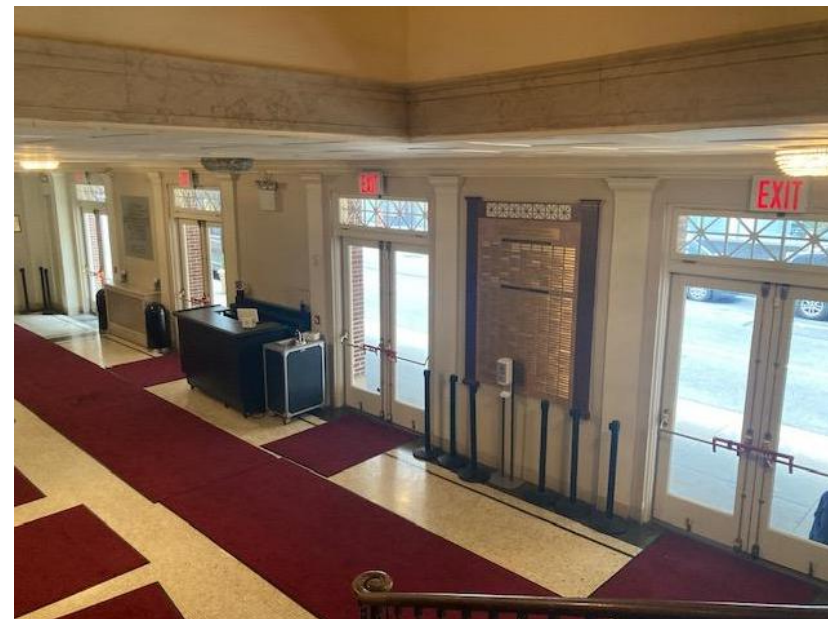

1.



2.

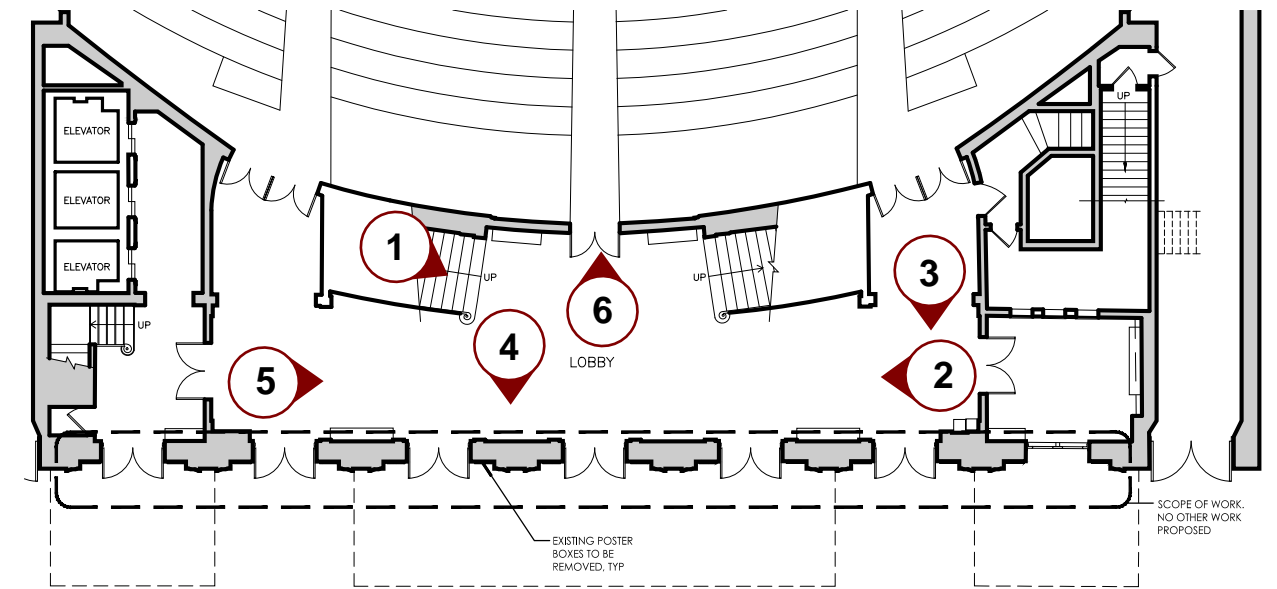

LOBBY IS INTERIOR DESIGNATED SPACE



3.



4.



5.



6.

EXISTING INTERIOR PHOTOS



PHOTOS C. 1950



HISTORIC PHOTOS



TAX PHOTOS C. 1940

HISTORIC PHOTOS



POSTER BOXES ON 43RD ST FACADE C. 1940

HISTORIC PHOTOS



POSTER BOXES C. 1940



HISTORIC PHOTOS



POSTER BOXES ON 43RD ST FACADE CURRENT

CURRENT PHOTOS



POSTER BOXES CURRENT



CURRENT PHOTOS

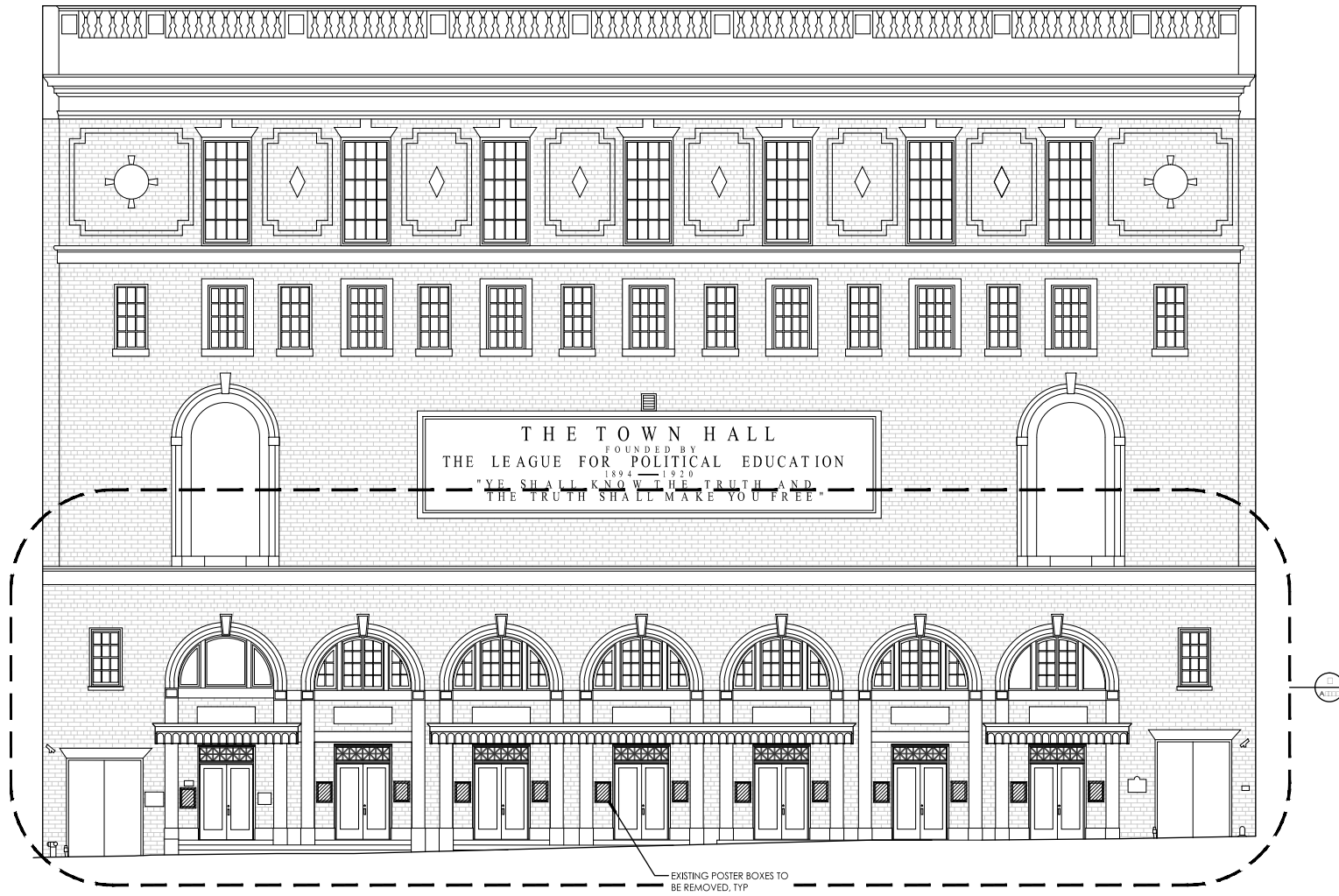

EXISTING ELEVATION

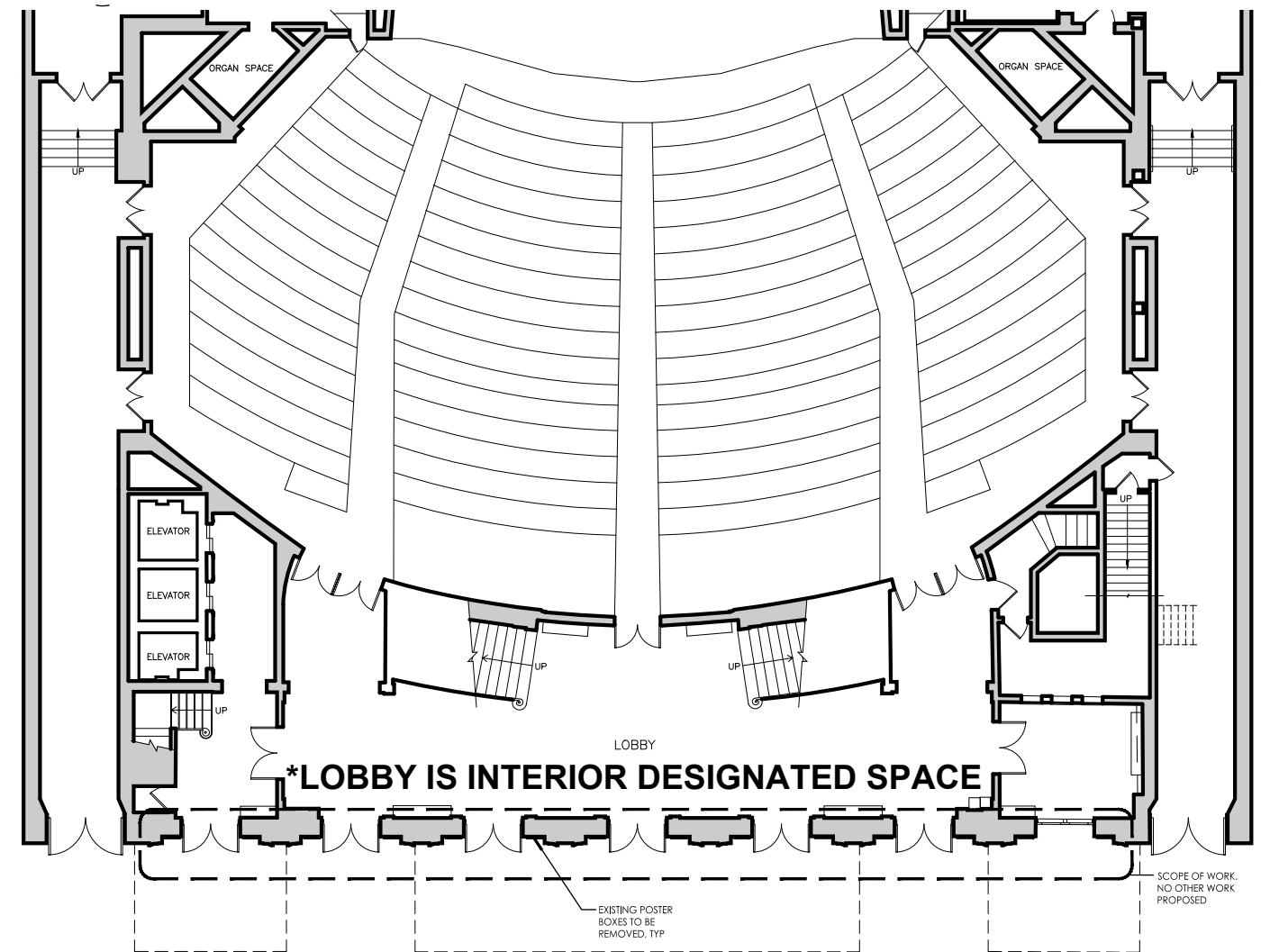

EXISTING PLAN

EXISTING ELEVATION & PLAN

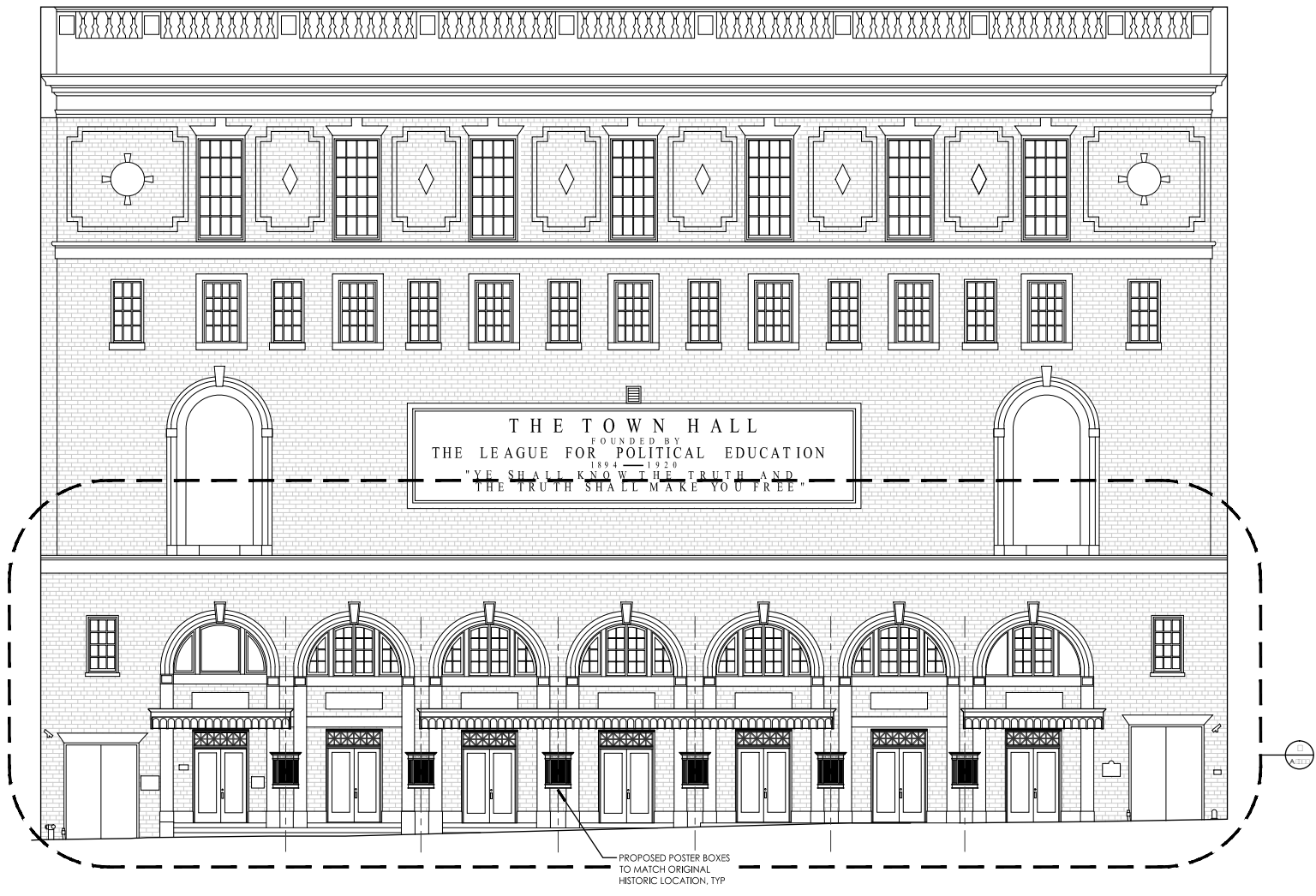

PROPOSED ELEVATION

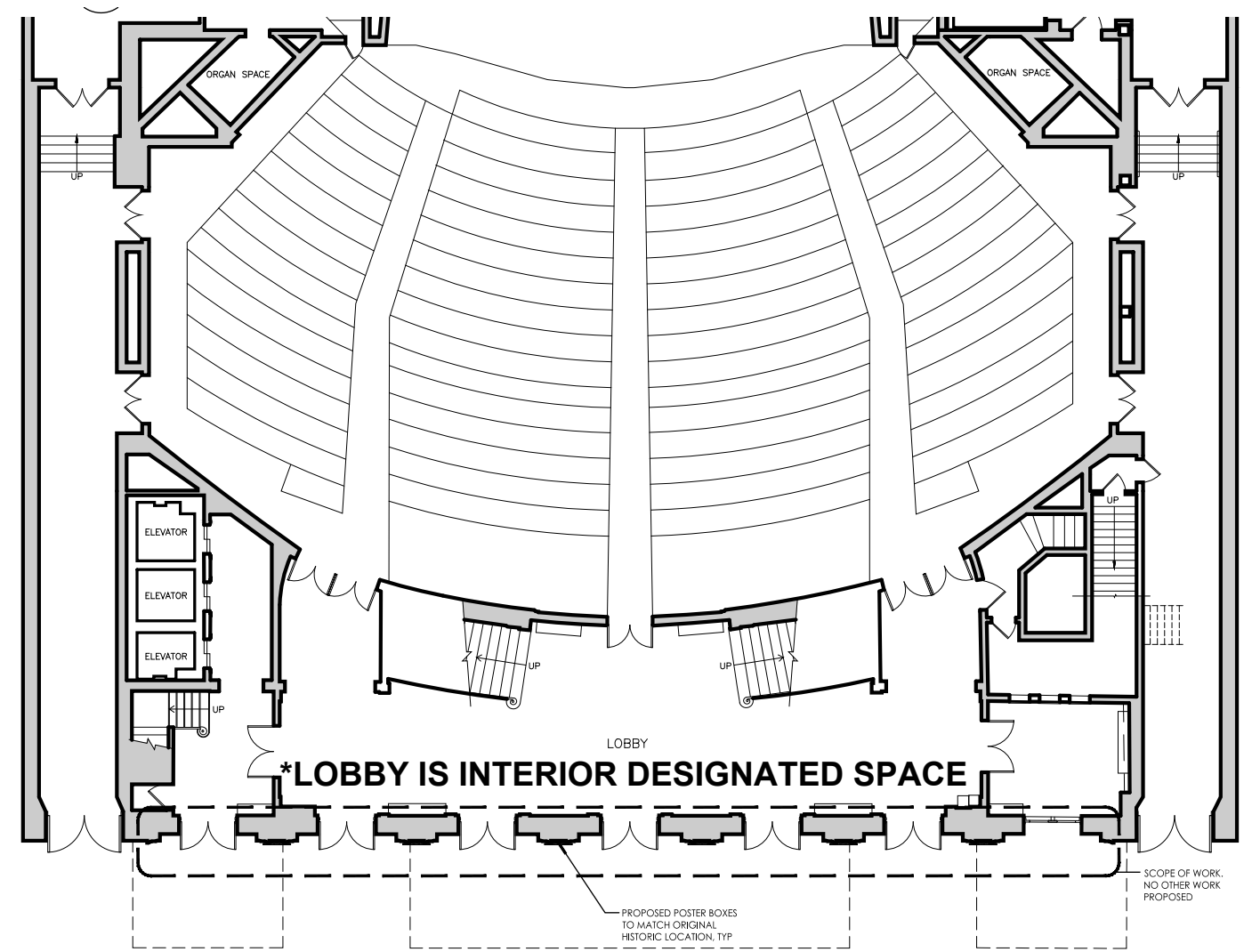

PROPOSED PLAN

PROPOSED ELEVATION & PLAN

1894 — 1920  
"YE SHALL KNOW THE TRUTH AND  
THE TRUTH SHALL MAKE YOU FREE"

EXISTING  
ELEVATION

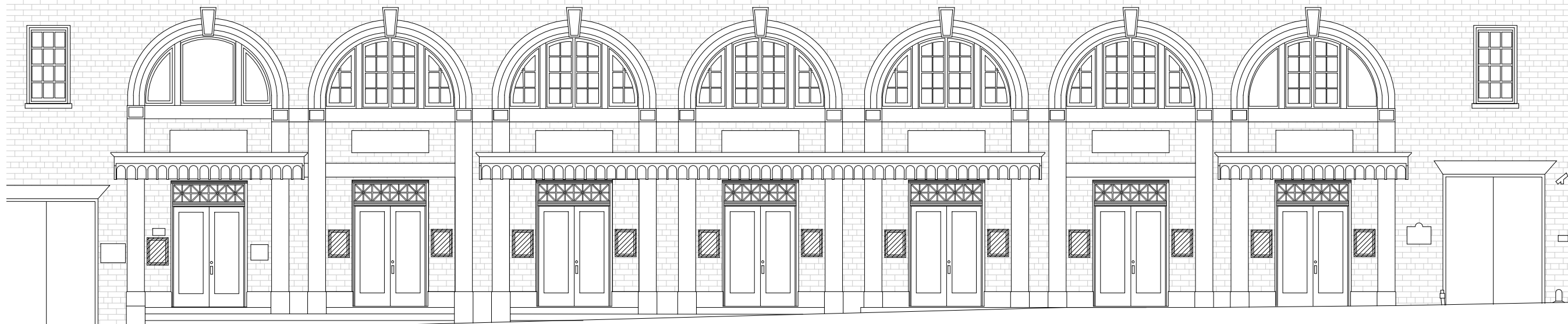

1894 — 1920  
"YE SHALL KNOW THE TRUTH AND  
THE TRUTH SHALL MAKE YOU FREE"

PROPOSED  
ELEVATION



EXISTING & PROPOSED ELEVATION



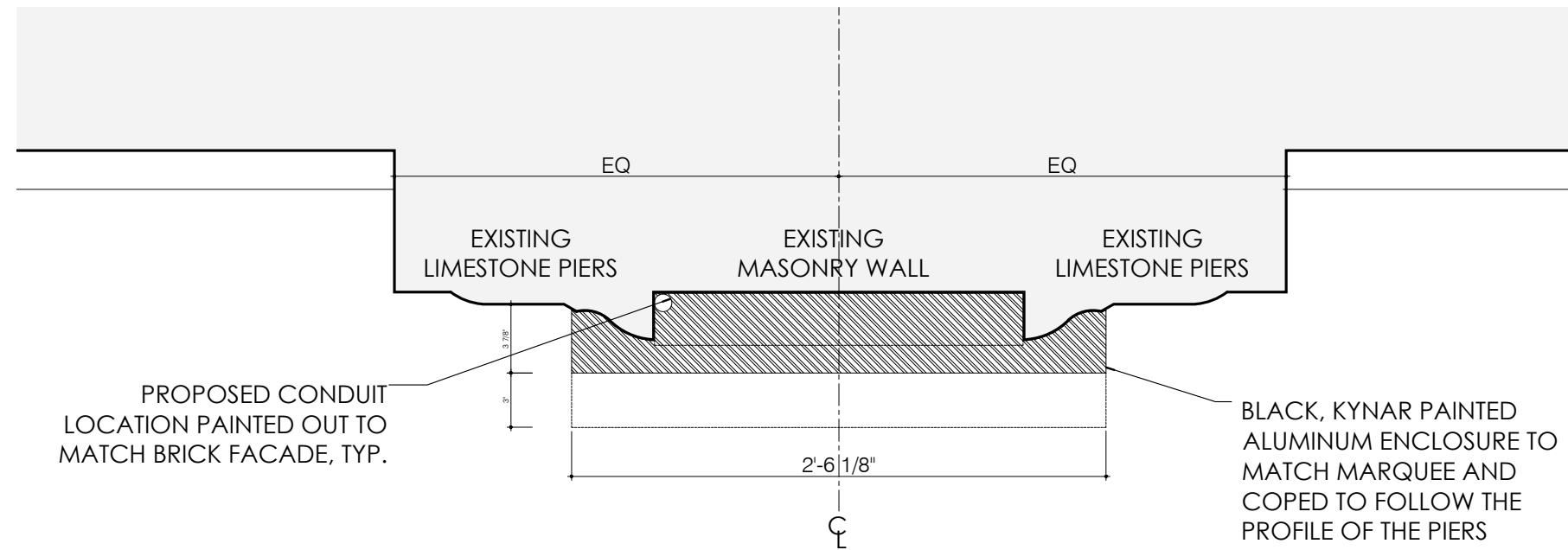

**TOP VIEW**

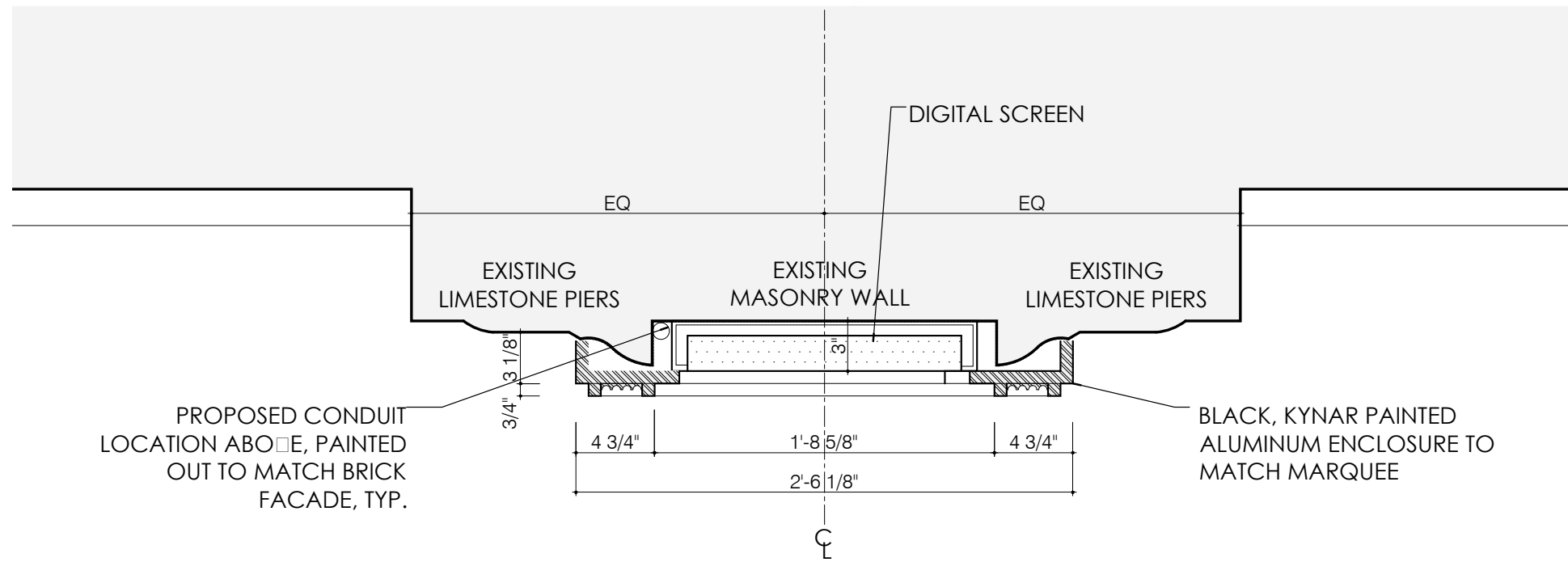

**PLAN DETAIL**

**PROPOSED PLAN TO MATCH HISTORIC**

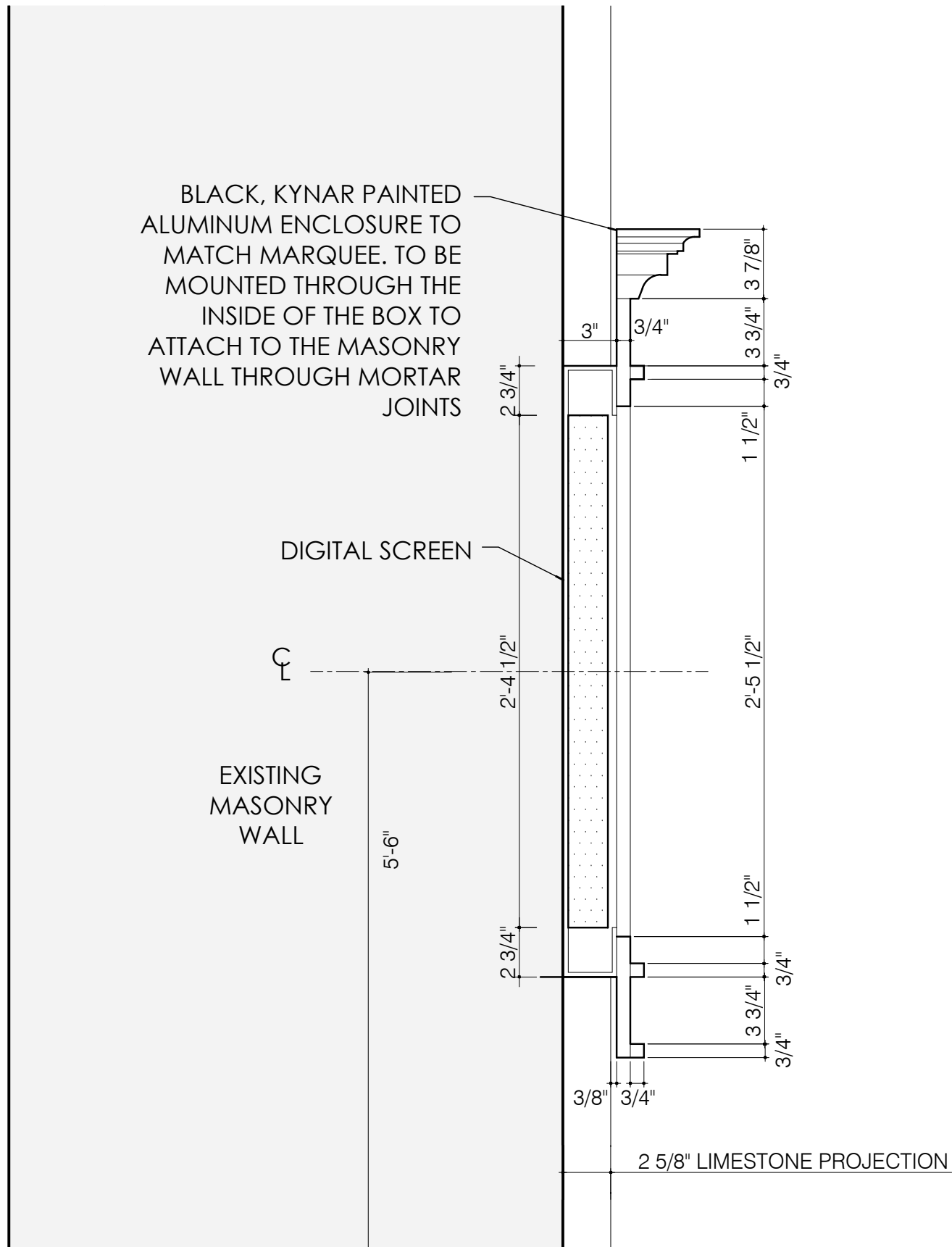

PROPOSED SECTION TO MATCH HISTORIC

Project Details

An example of the content

THE TOWN HALL AND THE AFRO LATIN JAZZ ALLIANCE PRESENT

# Dizzy, Chano and Chico

The Original Influencers –  
75 Years Later at Town Hall

**Arturo O’Farrill**  
& The Afro Latin Jazz Orchestra



Pedrito Martinez Daymé Arocena Jon Faddis Big Chief Donald Harrison

with Adam O’Farrill, Jacqueline Acevedo, Melvis Santa, Zack O’Farrill

**SATURDAY, JAN. 14, 2023**

THE TOWN HALL 123 W 43RD ST NYC | THETOWNHALL.ORG  
CONNECT: @TOWNHALLNYC

ticketmaster 800-745-3000

AN EVENING WITH ELLIOT PAGE

# PAGEBOY

BOOK EVENT



IN CONVERSATION WITH  
RAQUEL WILLIS

**TUESDAY, JUNE 6 | 7PM**

The Town Hall, New York, NY  
IN PARTNERSHIP WITH BARNES & NOBLE

BUY TICKETS TODAY AT  
ElliotPageBook.com

PAGEBOY  
ELLIOT PAGE

THE TOWN HALL IN ASSOCIATION WITH  
OFF THE KERB PRODUCTIONS PRESENT

THE BAFTA-WINNING STAR MAKES HIS AMERICAN DEBUT

# Alan Carr



CROSSING THE POND  
COMEDY FESTIVAL

**FRIDAY, NOV 17**

THE TOWN HALL 123 W 43RD ST NYC | THETOWNHALL.ORG  
CONNECT: @TOWNHALLNYC

ticketmaster 800-745-3000

THE TOWN HALL PRESENTS

# JUDY COLLINS: WILDFLOWERS

WITH THE HARLEM CHAMBER PLAYERS



**SATURDAY, FEB. 25, 2023 • 8PM**

THE TOWN HALL 123 W 43RD ST NYC | THETOWNHALL.ORG  
CONNECT: @TOWNHALLNYC

ticketmaster 800-745-3000

THE TOWN HALL PRESENTS | THU. + FRI. JUNE 25-26 • 8PM

# JOHN CAMERON MITCHELL + STEPHEN TRASK: THE ORIGIN OF LOVE

RETURN TO



SONGS AND STORIES OF  
HEDWIG WITH AMBER MARTIN  
AND VERY SPECIAL GUESTS

THE TOWN HALL 123 WEST 43RD STREET, NYC  
FOR TICKETS: (800) 745-3000 & TICKETMASTER.COM | BOX OFFICE HOURS: MON-FRI 12-6PM

OF THE KERO PRODUCTIONS PRESENT

# joanne mcnally

the prosecco express



“A TRULY GIFTED STAND UP”  
THE SUNDAY TIMES ★★★★★

“JOYOUSLY NUTS”  
THE EXAMINER ★★★★★

NEW DATE ADDED!

**NEW YORK THE TOWN HALL**  
SAT & SUNDAY ONLY **SOLD OUT**  
**FRI 3 FEBRUARY 2023**

THE TOWN HALL 123 W 43RD ST NYC | THETOWNHALL.ORG  
CONNECT: @TOWNHALLNYC

ticketmaster 800-745-3000

EXAMPLE OF CONTENT

## Project Details

### Technology

Mimo Monitors - 32" Outdoor P-Cap Display MOD-32080H



32" Outdoor Display (portrait configuration)

Durable, reliable, and beautifully vibrant, this small-format outdoor display works at an extended temperature range, from -20c to 60c (-4F to 140F) degrees, making it ideal year-round choice, no matter the temperature.

This commercial display is IP65 rated, allowing for hard use in nearly every weather condition, offering stunning, clear, crisp, and easy-to-see visuals both in sun and ambient lighting. A light sensor adjusts the display's brightness during cloudy days and at nighttime to optimize power consumption and ensure an ideal viewing experience.

### Specifications

Display	32" horizontal
Resolution	1920 x 1080
Brightness	1500 NITS
Contrast	1000:1
Aspect Ratio	16:9
Optic Bonded	Yes
Viewing Angle	85/85/85/85
I/O	Ethernet, HDMI, VGA, USB
Power Consumption	100-240VAC
IP Rating	IP65
Operating Temperature	-20c to 60c (-4F to 140F)
Product Dimensions	775x470x73mm
Product Weight	10-12kg

### Features

- IP 65 rating
- Optic bonded to reduce glare
- High bright, vivid screen
- PCAP touch - optional MOD-32080CH
- Wide operating temperature for very hot and very cold conditions
- Anti-glare cover glass
- VESA 200 mounting holes
- Optically bonded

## DIGITAL DISPLAY SPECIFICATIONS



**RADIO CITY MUSIC HALL**  
1260 6TH AVE



**MIDDLE COLLEGIATE CHURCH**  
112 2ND AVE



**ST. IGNATIUS LOYOLA CHURCH**  
99 E 84TH ST



**HUDSON THEATER**  
141 W. 44TH ST



**HAYES THEATER**  
240 W 44TH ST

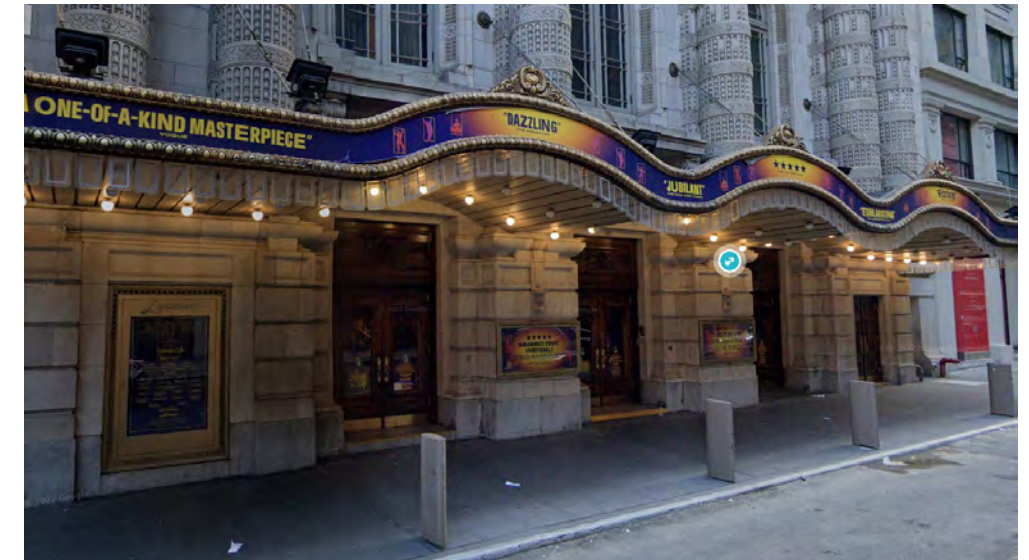

**LYCEUM THEATER**  
149 W 45TH ST

**LPC PRECEDENT**

1894 — 1920  
"YE SHALL KNOW THE TRUTH AND  
THE TRUTH SHALL MAKE YOU FREE"

EXISTING  
ELEVATION



1894 — 1920  
"YE SHALL KNOW THE TRUTH AND  
THE TRUTH SHALL MAKE YOU FREE"

PROPOSED  
ELEVATION



SUMMARY

**July 18, 2023**  
Public Hearing

The current proposal is:

**Preservation Department – Item 4, LPC-23-08522**

**123 West 43rd Street – The Town Hall – Individual and  
Interior Landmark  
Borough of Manhattan**

To testify virtually, please join Zoom

**Webinar ID:** 864 9888 2944

**Passcode:** 903125

By Phone: 1 646-558-8656 US (New  
York) 877-853-5257 (Toll free) US  
888 475 4499 (Toll free)

**Note:** If you want to testify virtually on an item, join the Zoom webinar at the agenda's "Be Here by" time (about an hour in advance). When the Chair indicates it's time to testify, "raise your hand" via the Zoom app if you want to speak (\*9 on the phone). Those who signed up in advance will be called first.