

The current proposal is:

Preservation Department – Item 2, LPC-22-07187

**144 Greenpoint Avenue – Greenpoint Historic District  
Borough of Manhattan**

**Note: this is a Public Meeting item. No public testimony will be received today as the hearing on this item is closed**



LPC 111522 PRESENTATION



REVISED 12.01.22

- 1. CORNICE MOVED UP BY 1'-0"
- 2. THIRD FLOOR WINDOWS TALLER BY 8"
- 3. HEIGHT OF CHANNEL INCREASED BY 4"
- 4. BRICK PIER INCREASED BY 8"
- 5. RETAIL CANOPIES ELIMINATED, SIGNAGE LOCATED BELOW ALUMINUM PLATE
- 6. DEPTH OF BUILDING ENTRY CANOPY REDUCED BY 3'-0"
- 7. HORIZONTAL CHANNEL MOVED UP BY 8"
- 8. TOP OF WINDOW INCREASED BY 8"
- 9. STAIR BULKHEAD REDUCED IN HEIGHT BY 6"
- 10. ELEVATOR BULKHEAD REDUCED IN HEIGHT BY 1'-2"
- 11. ROOF LOWERED BY 1'-6"



LPC 111522 PRESENTATION



REVISED 12.01.22

1. STAIR BULKHEAD ROOF LOWERED BY 1'-4"
2. TOP OF PARAPET REMAINS THE SAME
3. HORIZONTAL CHANNEL MOVED UP BY 8"
4. TOP OF WINDOW INCREASED BY 8"
5. CORNICE MOVED UP BY 1'-0"
6. THIRD FLOOR WINDOWS TALLER BY 8"
7. HEIGHT OF CHANNEL INCREASED BY 4"
8. BRICK PIER INCREASED BY 8"
9. RETAIL CANOPIES ELIMINATED, SIGNAGE LOCATED BELOW ALUMINUM PLATE
10. DEPTH OF BUILDING ENTRY CANOPY REDUCED BY 3'-0"



LPC 1.11522 PRESENTATION



REVISED 12.01.22

1. TOP OF PARAPET LOWERED BY 1'-8"
2. TOP OF ROOF LOWERED BY 1'-8"
3. MECHANICAL EQUIPMENT LOWERED BY 1'-2"
4. STAIR BULKHEAD REDUCED IN HEIGHT BY 6"
5. ELEVATOR BULKHEAD REDUCED IN HEIGHT BY 1'-2"
6. RAILING PUSHED BACK 3'-0"
7. ROOF LOWERED BY 1'-6"



LPC 111522 PRESENTATION



REVISED 12.01.22



LPC 111522 PRESENTATION

REVISED 12.01.22

**PBDW** ARCHITECTS

Copyright © 2022 Platt Byard Doveff White Architects LLP All Rights Reserved

FROM VIEW 2 ON LPC-28  
VIEW COMPARISON OF PROPOSED BUILDING FROM 123 GREENPOINT AVENUE  
12.01.2022

144 Greenpoint Avenue  
NYC Landmarks Preservation Commission



LPC 111522 PRESENTATION



REVISED 01.20.23



LPC 111522 PRESENTATION



REVISED 01.20.23





LPC 111522 PRESENTATION



REVISED 01.20.23



LPC 111522 PRESENTATION



REVISED 01.20.23



LPC 111522 PRESENTATION



REVISED 12.01.22

REVISED 12.01.22

- 1. RETAIL CANOPIES ELIMINATED
- 2. SIGNAGE LOCATED BELOW ALUMINUM PLATE
- 3. TEXT HEIGHT REDUCED TO 1'-0"
- 4. DEPTH OF BUILDING ENTRY CANOPY REDUCED BY 3'-0"
- 5. TEXT HEIGHT REDUCED TO 1'-0"



1. MAIN BUILDING ENTRY SIGNAGE

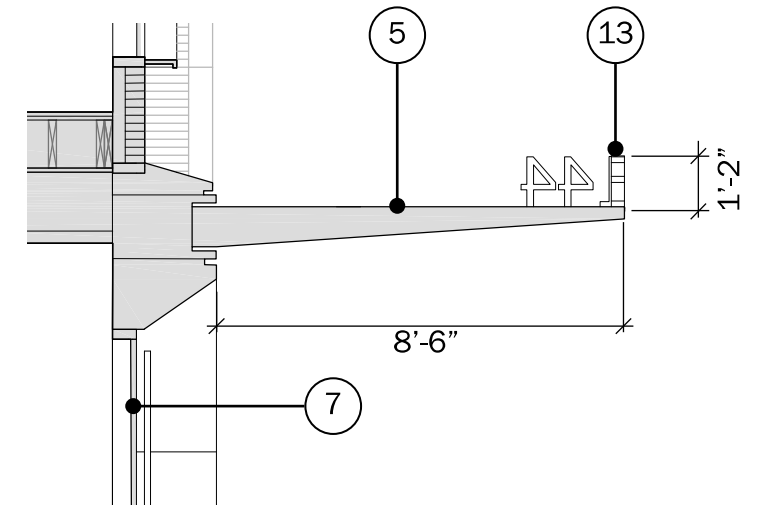

SECTION A-A

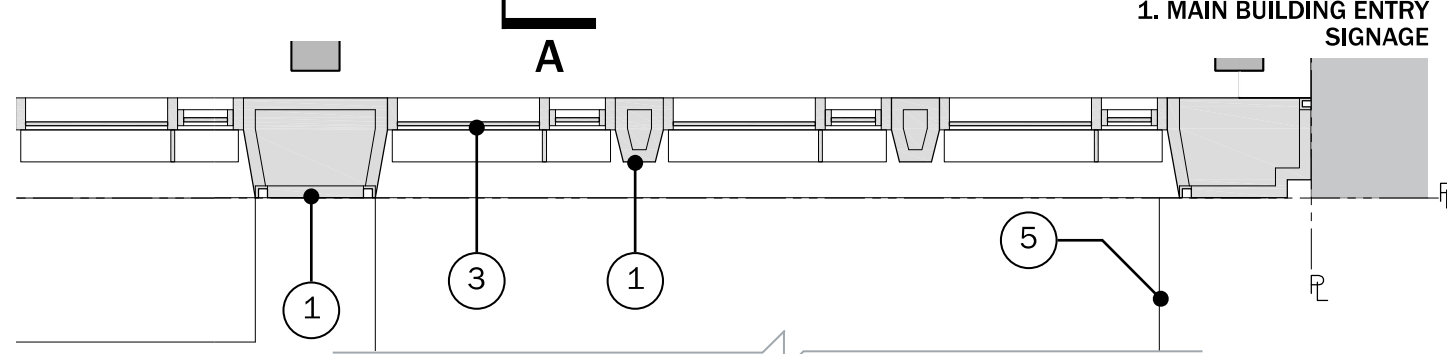

2. TYPICAL RETAIL CANOPY SIGNAGE

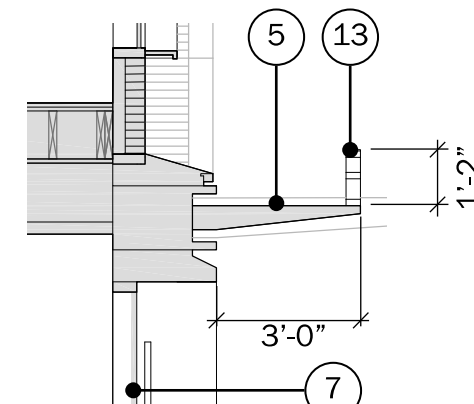

SECTION B-B

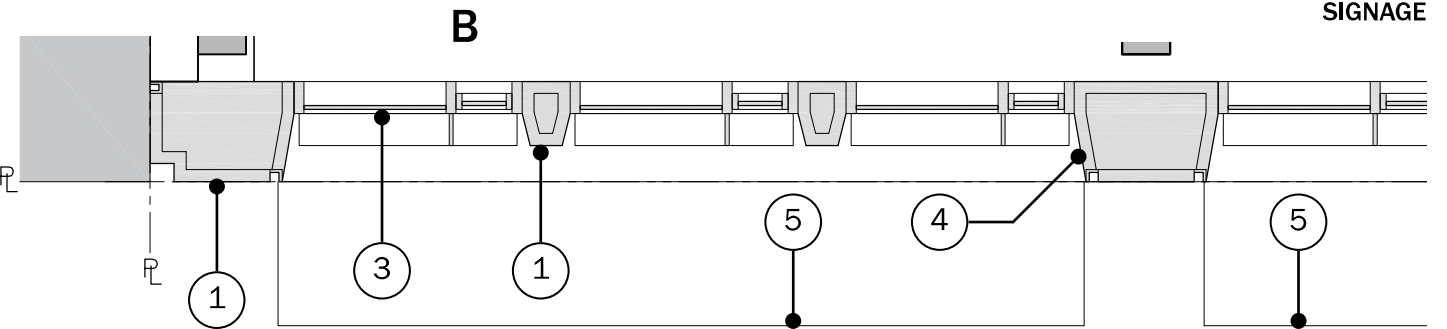

KEY ○

1. PANELIZED BRICK ON METAL STUD ASSEMBLY, STACK BOND
2. PAINTED ALUMINUM PLATE AT CHANNEL ASSEMBLY
3. PAINTED ALUMINUM AND GLASS WINDOW WALL ASSEMBLY
4. PAINTED ALUMINUM PANEL
5. PAINTED ALUMINUM METAL PANEL CANOPY
6. PAINTED ALUMINUM AND GLASS DOOR ASSEMBLY
7. PAINTED ALUMINUM AND GLASS STOREFRONT
8. GFRC PANEL ASSEMBLY
9. STUCCO PARAPET WALL
10. PAINTED ALUMINUM CORNICE ASSEMBLY
11. PAINTED ALUMINUM CHANNEL ASSEMBLY
12. FORMED AND PAINTED METAL STANDING SEAM CLADDING
13. FORMED AND PAINTED ALUMINIUM PIN LETTERS
14. PAINTED STEEL PIPE RAILING (TYP. AT ROOF)
15. MECHANICAL EQUIPMENT



0 1' 2' 4'  
1/4" = 1'-0"

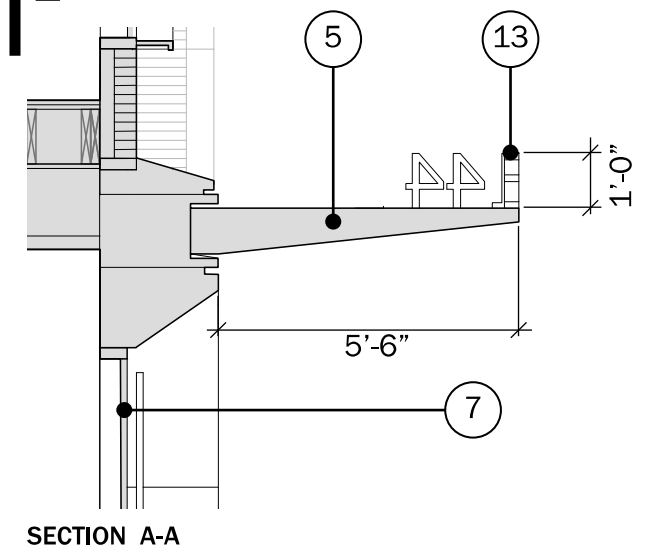
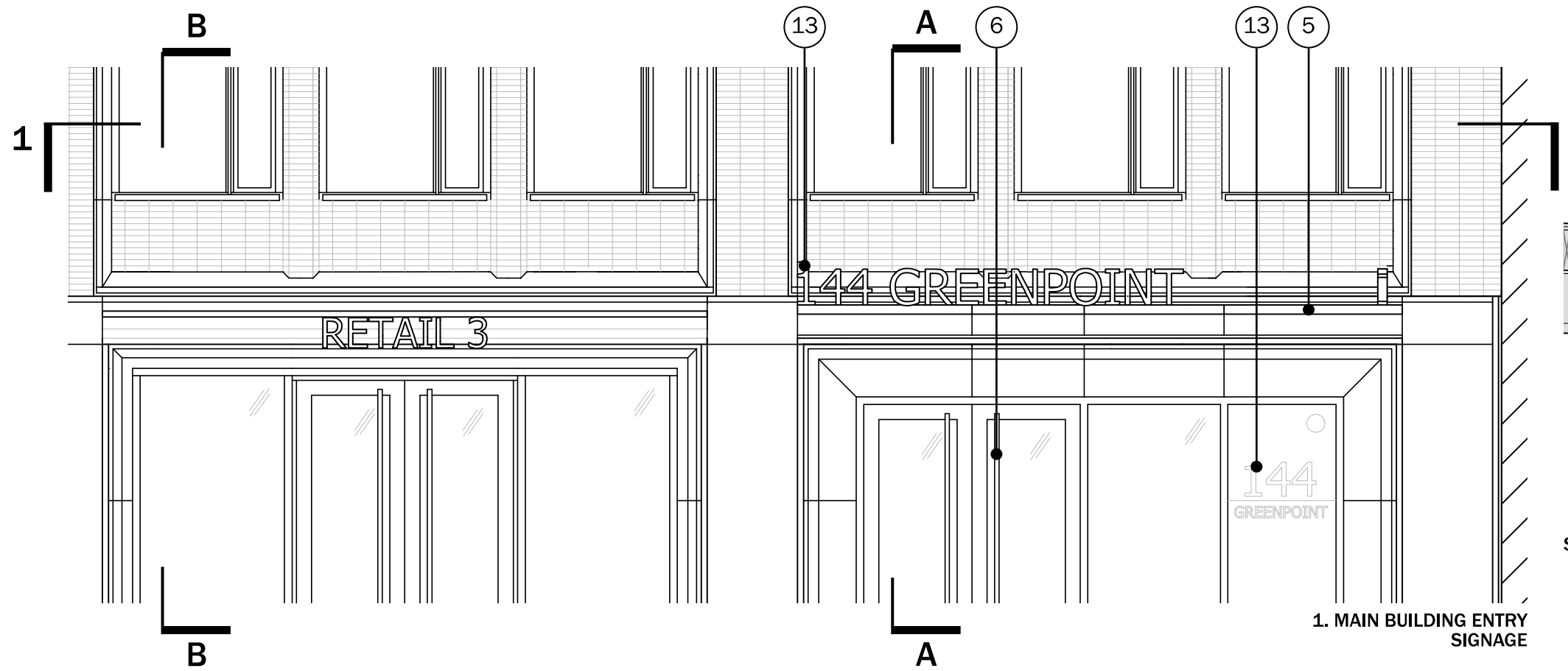

SECTION A-A

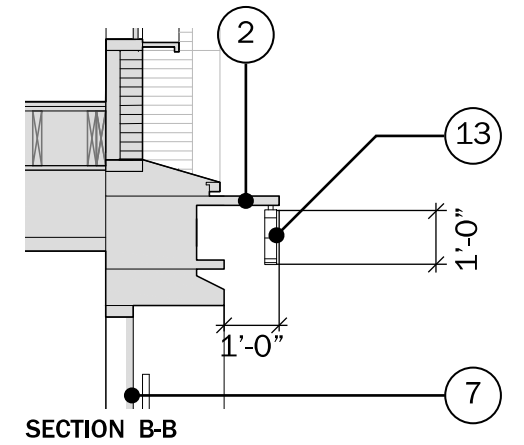

SECTION B-B

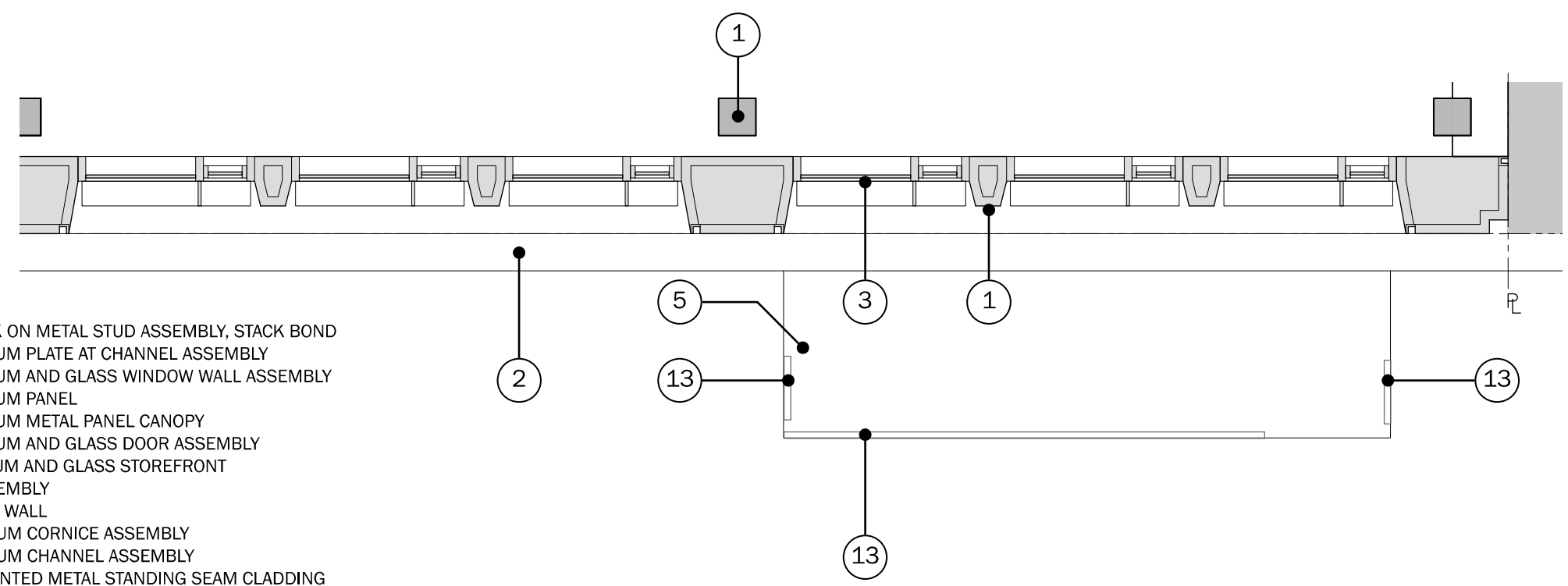

- KEY ○
1. PANELIZED BRICK ON METAL STUD ASSEMBLY, STACK BOND
  2. PAINTED ALUMINUM PLATE AT CHANNEL ASSEMBLY
  3. PAINTED ALUMINUM AND GLASS WINDOW WALL ASSEMBLY
  4. PAINTED ALUMINUM PANEL
  5. PAINTED ALUMINUM METAL PANEL CANOPY
  6. PAINTED ALUMINUM AND GLASS DOOR ASSEMBLY
  7. PAINTED ALUMINUM AND GLASS STOREFRONT
  8. GFRC PANEL ASSEMBLY
  9. STUCCO PARAPET WALL
  10. PAINTED ALUMINUM CORNICE ASSEMBLY
  11. PAINTED ALUMINUM CHANNEL ASSEMBLY
  12. FORMED AND PAINTED METAL STANDING SEAM CLADDING
  13. FORMED AND PAINTED ALUMINIUM PIN LETTERS
  14. PAINTED STEEL PIPE RAILING (TYP. AT ROOF)
  15. MECHANICAL EQUIPMENT

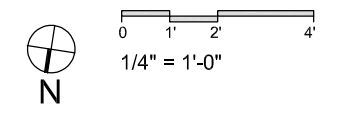

The current proposal is:

Preservation Department – Item 2, LPC-22-07187

**144 Greenpoint Avenue – Greenpoint Historic District  
Borough of Manhattan**

**Note: this is a Public Meeting item. No public testimony will be received today as the hearing on this item is closed**