

The current proposal is:

Preservation Department – Item 4, LPC-23-00447

421 West 13th Street – Gansevoort Market Historic District Borough of Manhattan

To Testify Please Join Zoom

Webinar ID: 846 5008 0041

Passcode: 554001

By Phone: 1 646-558-8656 US (New York)

877-853-5257 (Toll free) US

888 475 4499 (Toll free)

Note: If you want to testify on an item, join the Zoom webinar at the agenda’s “Be Here by” time (about an hour in advance). When the Chair indicates it’s time to testify, “raise your hand” via the Zoom app if you want to speak (*9 on the phone). Those who signed up in advance will be called first.



Tax Photo, 1940's



2022

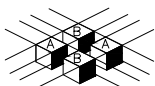

ABBArchitecture
anita@abbarchitecture.com

421 - 425 West 13th Street, NY
Sidewalk steps and landing at Restaurant Entrance

DATE
Sept 20, 2022

SCALE
N.T.S.

LPC-1



Plot plan

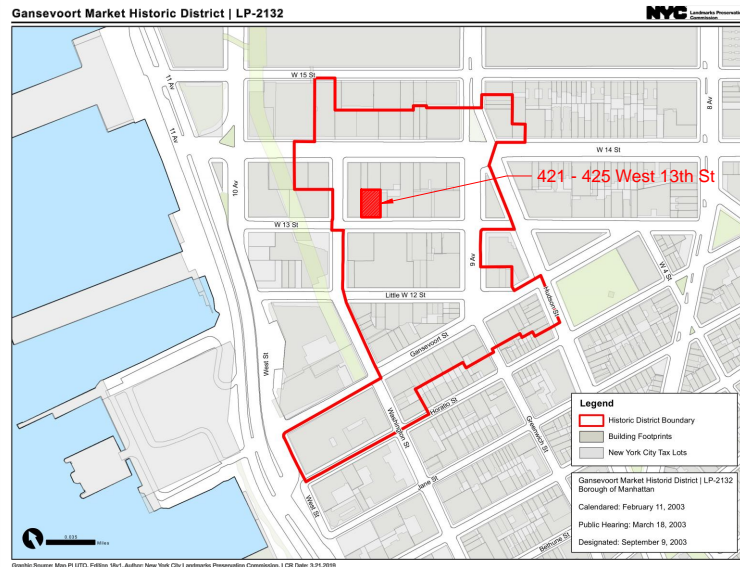

Gansevoort Market Historic District Map

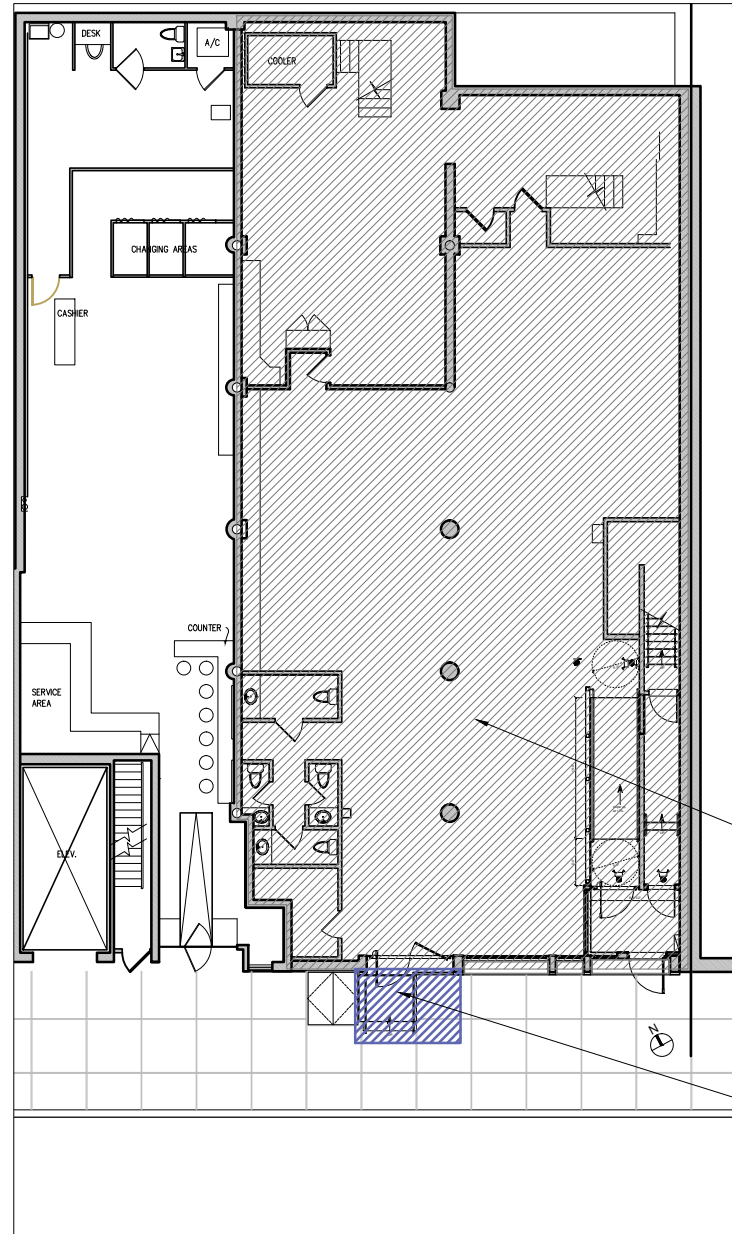

421-425 West 13th Street ground floor plan

Restaurant space

Area of work

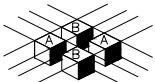

ABBArchitecture
anita@abbarchitecture.com

421 - 425 West 13th Street, NY
Sidewalk steps and landing at Restaurant Entrance

DATE
Sept 20, 2022

SCALE
N.T.S.

LPC-2

Existing conditions

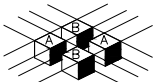
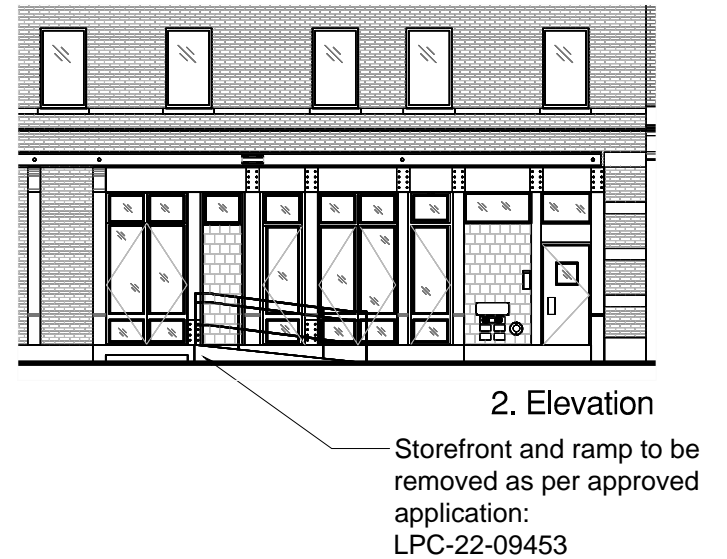
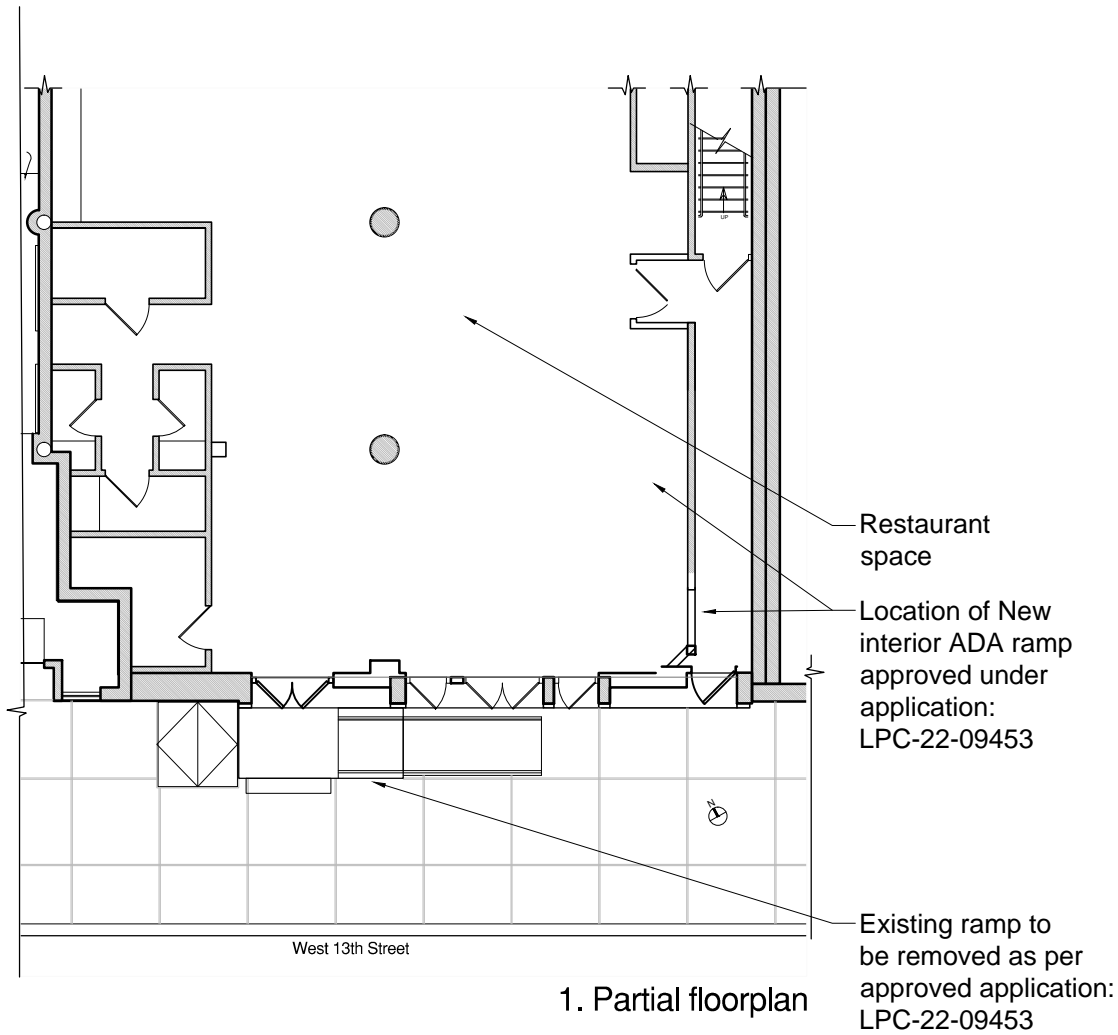

ABBArchitecture
anita@abbarchitecture.com

421 - 425 West 13th Street, NY
Sidewalk steps and landing at Restaurant Entrance

DATE
Sept 20, 2022

SCALE
N.T.S.

LPC-3

Layout as approved under application
LPC-22-09453

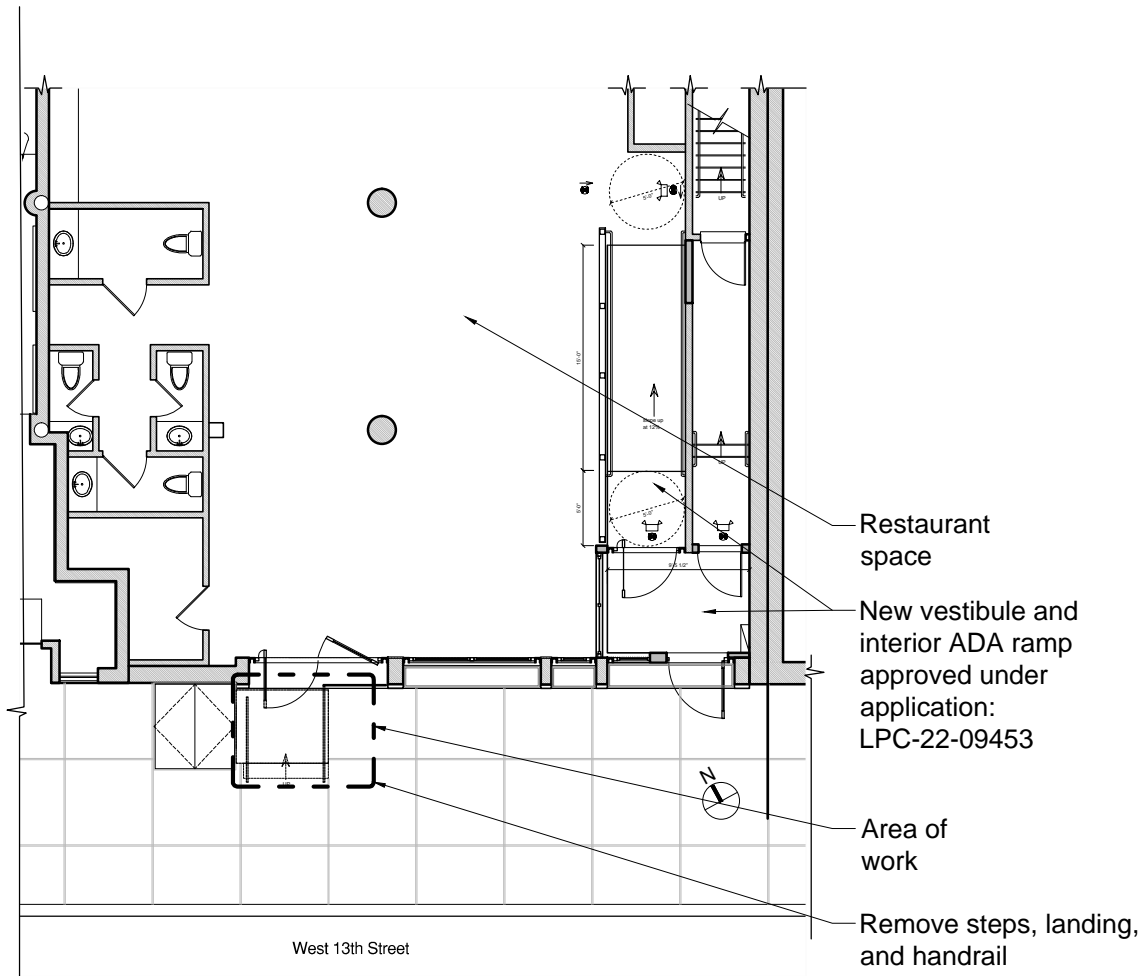

1. Partial floorplan

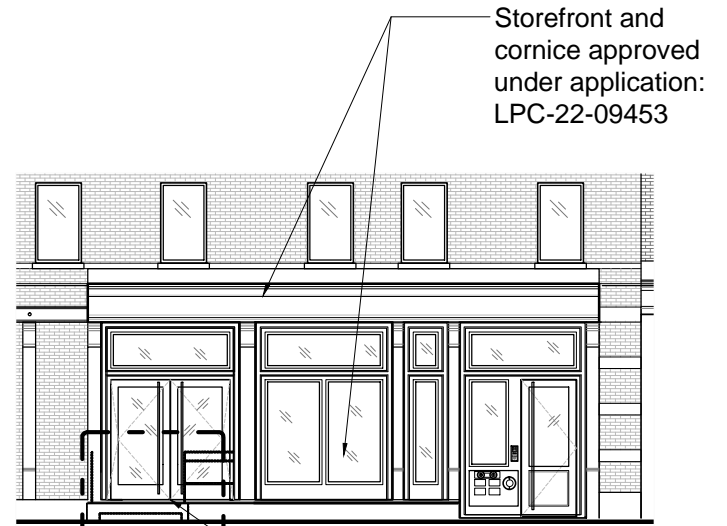

Storefront and cornice approved under application:
LPC-22-09453

2. Elevation

Remove existing steps and landing, and handrail

Area of work

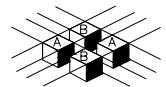

ABBArchitecture
anita@abbarchitecture.com

421 - 425 West 13th Street, NY
Sidewalk steps and landing at Restaurant Entrance

DATE
Sept 20, 2022

SCALE
N.T.S.

LPC-4

Existing concrete landing

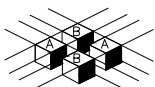
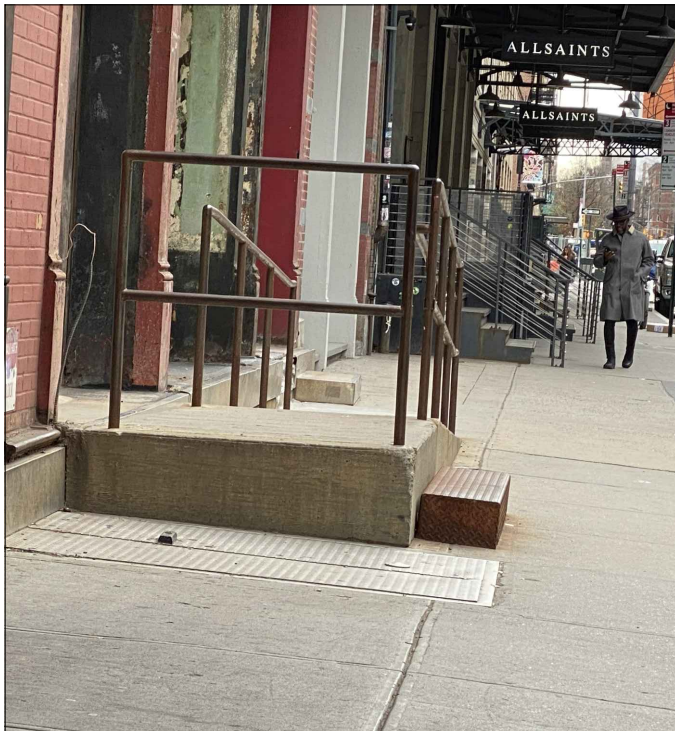

ABBArchitecture
anita@abbarchitecture.com

421 - 425 West 13th Street, NY
Sidewalk steps and landing at Restaurant Entrance

DATE
Sept 20, 2022

SCALE
N.T.S.

LPC-5

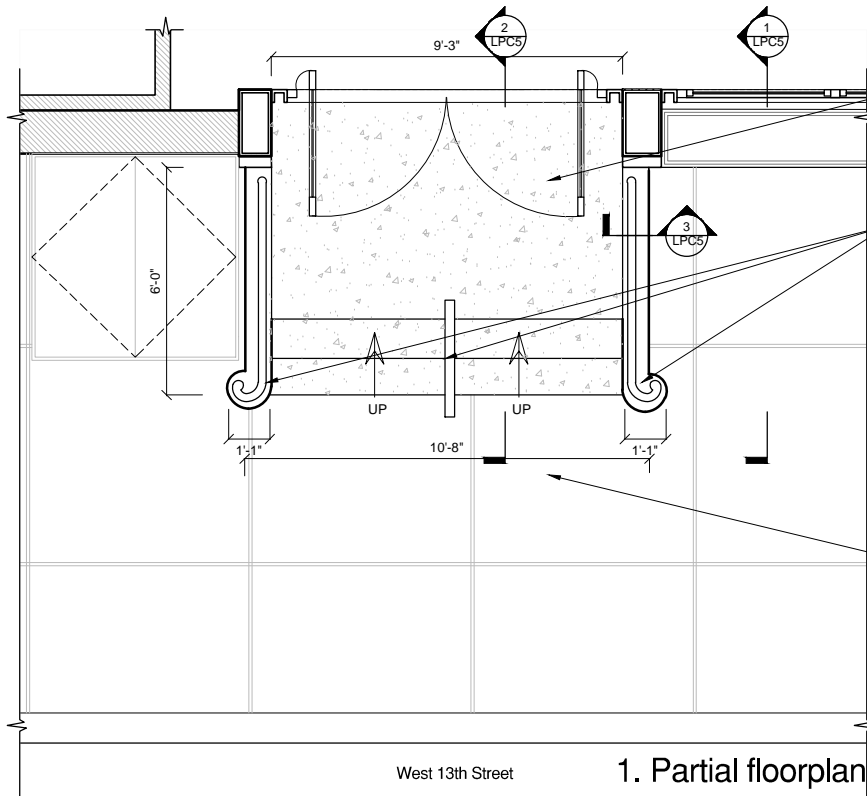

Steps and landing in concrete, to match sidewalk in color, material, and texture

Metal railing, smooth finishing, painted black

Patch and repair concrete sidewalk to match existing in color, material, and texture

West 13th Street 1. Partial floorplan

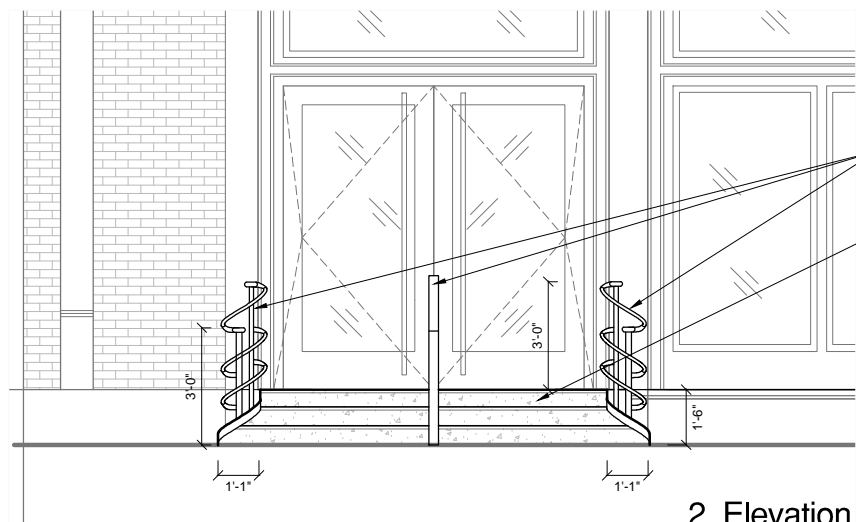

Metal railing, smooth finishing, painted black

3 risers @ 6"
2 treads @ 12"

2. Elevation

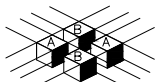

ABBArchitecture
anita@abbarchitecture.com

421 - 425 West 13th Street, NY
Sidewalk steps and landing at Restaurant Entrance

DATE
Sept 20, 2022

SCALE
N.T.S.

LPC-6

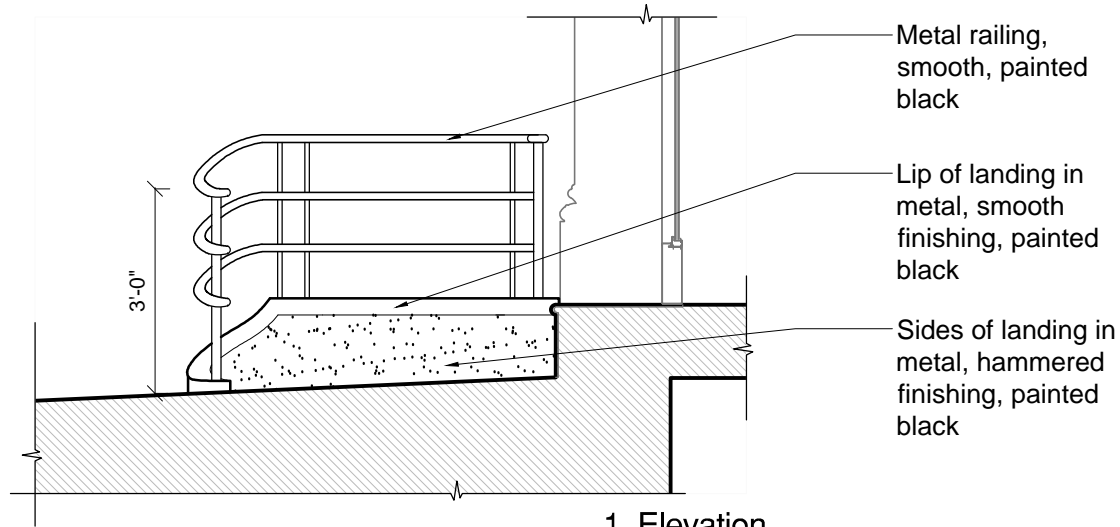

1. Elevation

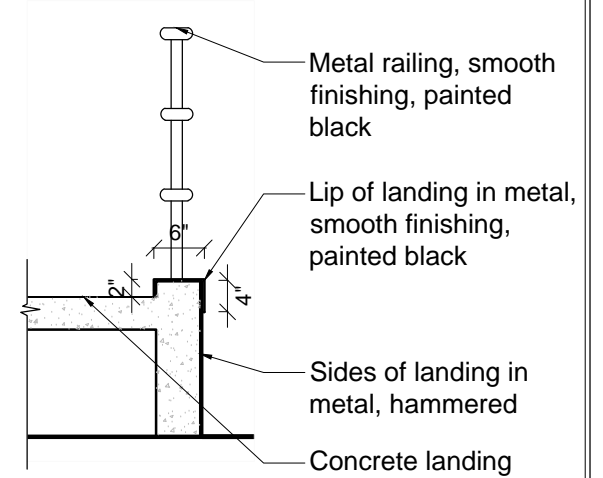

3. Handrail section

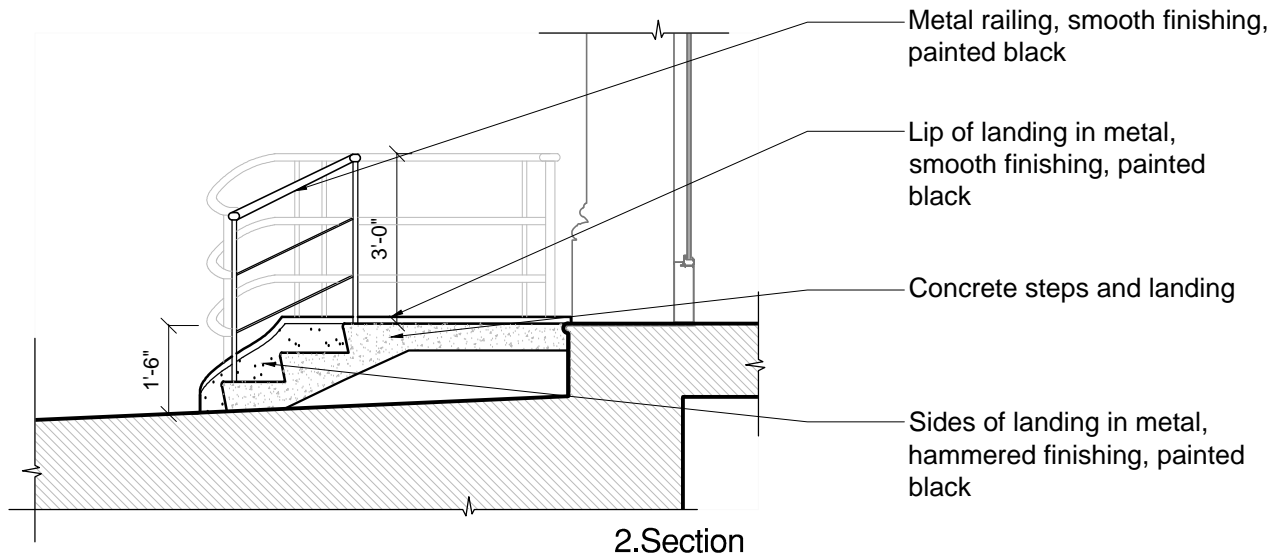

2. Section

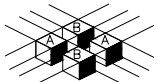

ABBArchitecture
 anita@abbarchitecture.com

421 - 425 West 13th Street, NY
 Sidewalk steps and landing at Restaurant Entrance

DATE
 Sept 20, 2022

SCALE
 N.T.S.

LPC-7

Neighborhood Context:
415 West 13th Street

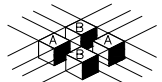
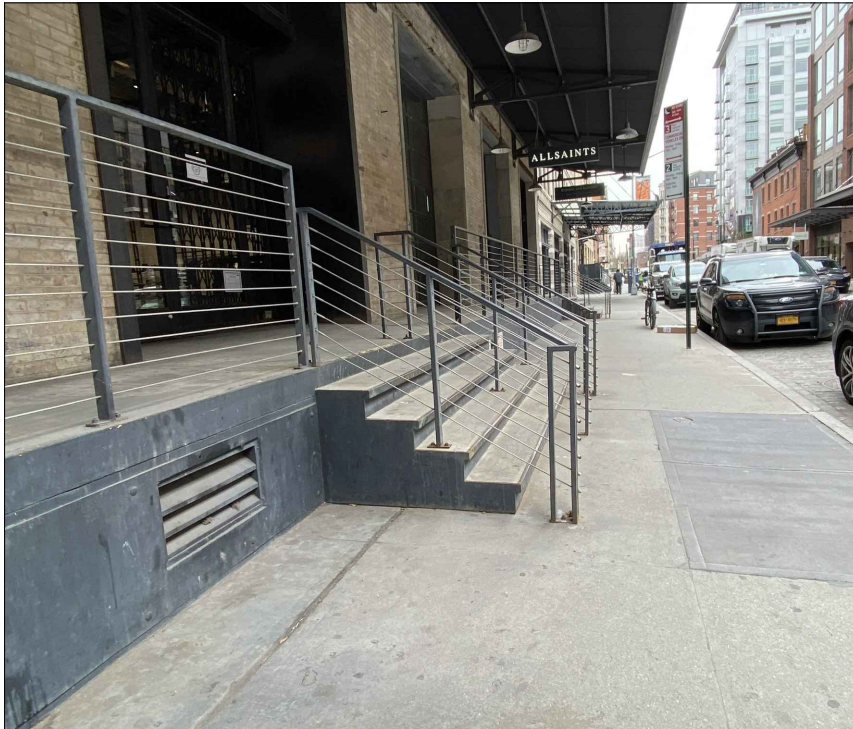

ABBArchitecture
anita@abbarchitecture.com

421 - 425 West 13th Street, NY
Sidewalk steps and landing at Restaurant Entrance

DATE
Sept 20, 2022

SCALE
N.T.S.

LPC-8

Neighborhood Context:
403 West 13th Street

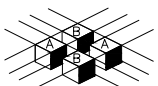

ABBArchitecture
anita@abbarchitecture.com

421 - 425 West 13th Street, NY
Sidewalk steps and landing at Restaurant Entrance

DATE
Sept 20, 2022

SCALE
N.T.S.

LPC-9

The current proposal is:

Preservation Department – Item 4, LPC-23-00447

421 West 13th Street – Gansevoort Market Historic District Borough of Manhattan

To Testify Please Join Zoom

Webinar ID: 846 5008 0041

Passcode: 554001

By Phone: 1 646-558-8656 US (New York)

877-853-5257 (Toll free) US

888 475 4499 (Toll free)

Note: If you want to testify on an item, join the Zoom webinar at the agenda’s “Be Here by” time (about an hour in advance). When the Chair indicates it’s time to testify, “raise your hand” via the Zoom app if you want to speak (*9 on the phone). Those who signed up in advance will be called first.