

The current proposal is:

Preservation Department – Item 2, LPC-22-11753

108 Shore Road – Douglaston Historic District
Borough of Queens

To Testify Please Join Zoom

Webinar ID: 846 5008 0041

Passcode: 554001

By Phone: 1 646-558-8656 US (New York)

877-853-5257 (Toll free) US

888 475 4499 (Toll free)

Note: If you want to testify on an item, join the Zoom webinar at the agenda’s “Be Here by” time (about an hour in advance). When the Chair indicates it’s time to testify, “raise your hand” via the Zoom app if you want to speak (*9 on the phone). Those who signed up in advance will be called first.



FORGIONE RESIDENCE
108 SHORE ROAD

DOUGLASTON, NY 11363

DADRAS ARCHITECTS

234-21 41ST AVENUE
DOUGLASTON, NY 11363
212 239-8293

**NYC-LANDMARKS PRESERVATION
COMMISSION**

SUBMISSION DATE: 09/12/22



AREA CALCULATIONS

EXISTING FLOOR AREA

EXISTING CELLAR FLOOR : 1,250 SF
 EXISTING FIRST FLOOR : 1,401 SF
 EXISTING SECOND FLOOR : 1,204 SF
 ATTIC FLOOR AREA : 0 SF
TOTAL EXISTING ZONING FLOOR AREA : 2,605 SF

PROPOSED FLOOR AREA

CELLAR FLOOR ADDITION : 1,250 SF Net Addition = 0 SF (NO CHANGE)
 FIRST FLOOR ADDITION : 1,823 SF Net Addition = 422 SF
 SECOND FLOOR ADDITION : 2,039 SF Net Addition = 835 SF
 ATTIC FLOOR AREA : 1,184 SF Net Addition = 1,184 SF
TOTAL PROPOSED ZONING FLOOR AREA : 5,046 SF Net Addition = 2,441 SF

- EXISTING PROJECT SITE
- PROPOSED PROJECT ADDITION/ EXTENSION

FORGIONE RESIDENCE

108 SHORE ROAD

DOUGLASTON, NY 11363

DADRAS ARCHITECTS

234-21 41ST AVENUE
 DOUGLASTON, NY 11363
 212 239-8293

NYC-LANDMARKS PRESERVATION COMMISSION

SUBMISSION DATE:08/31/22

LOCATION PLAN



EXISTING WEST VIEW_SHORE ROAD



EXISTING NORTH VIEW_HOLLYWOOD AVENUE

FORGIONE RESIDENCE

108 SHORE ROAD

DOUGLASTON, NY 11363

DADRAS ARCHITECTS

234-21 41ST AVENUE
DOUGLASTON, NY 11363
212 239-8293

NYC-LANDMARKS PRESERVATION COMMISSION

SUBMISSION DATE:08/31/22

FORGIONE RESIDENCE

108 Shore Road
Douglaston, NY 11363

CLARIFICATION of “Historic – Non-Contributing Structure” STATUS

UNFORTUNATELY, our Property Site is very much INCORRECTLY DESCRIBED, in the “DOUGLASTON HISTORIC DISTRICT Designation Report”, dated June 24, 1997, and in fact should be re-classified and considered as a “**Non-Contributing Structure**” due primarily to the fact that it was built in 1955, and secondarily that it does not contain historic features or value that are important to the Douglaston Historic District.

“Contributing building” shall mean a building in the Douglaston Historic District built, in whole or in part, prior to January 1, 1945, including buildings that have undergone subsequent remodeling and alterations, and the following properties built after December 31, 1944: 8 Beverly Road, 321 Hollywood Avenue, 350 Ridge Road and 6 Knollwood. In addition, a new building or a building with a substantial addition or modification approved by the Commission shall be deemed a contributing building for purposes of the master plan. - DLNHS

We contend that “there is nothing that distinguishes 108 Shore Road, designed and built in 1955, either architecturally or culturally, as significant for its time or in any way representative of significant architecture of the post war era in Douglas Manor.”

FORGIONE RESIDENCE

108 SHORE ROAD

DOUGLASTON, NY 11363

DADRAS ARCHITECTS

234-21 41ST AVENUE
DOUGLASTON, NY 11363
212 239-8293

NYC-LANDMARKS PRESERVATION COMMISSION

SUBMISSION DATE:08/31/22

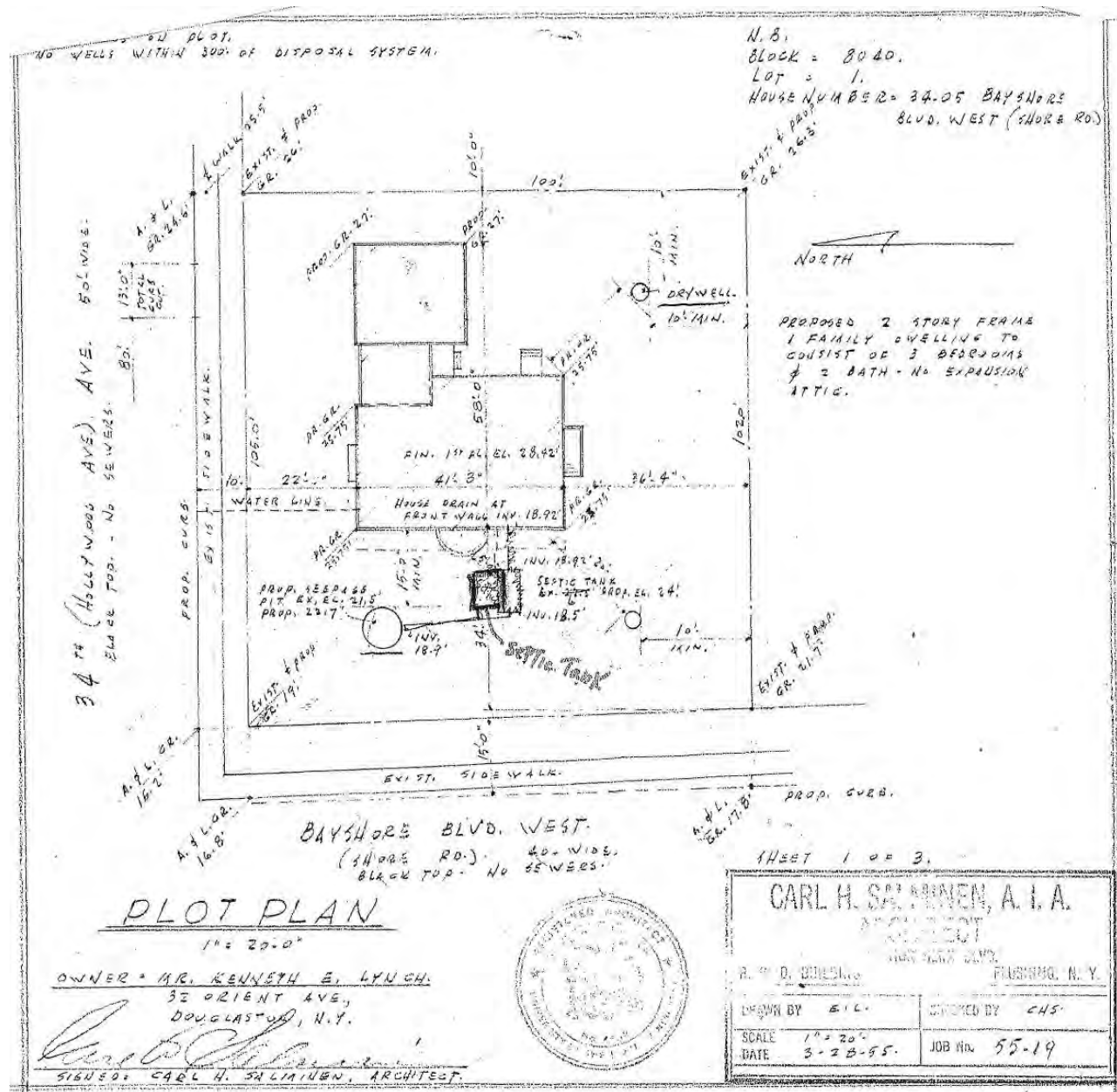

OWNERS: MR. & MRS.
KENNETH LYNCH
 32 ORIENT AVE.
 DOUGLASTON, N.Y.

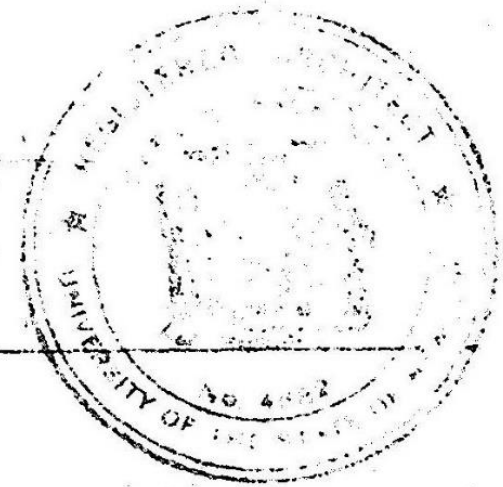

CARL H. SALMINEN, A. I. A. ARCHITECT 150-30 HUNTERTON BLVD. R. K. O. BUILDING DOUGLASS, N. Y.	
DRAWN BY <i>E.L.</i>	CHECKED BY <i>CHS & E.L.</i>
SCALE <i>1/4" = 1'-0"</i>	JOB No. <i>55-22</i>
DATE <i>APRIL 1, 1955</i>	

ORIGINAL PLOT PLAN – filed by the building’s architect: Carl H. Salminem, AIA (NOT the architect A.P. Wohlpart? incorrectly mentioned in the Designation Report) in April 1,1955 (NOT in 1920?, as per the Designation Report) for Owners: Mr. & Mrs. Kenneth Lynch (NOT owner A.L. Daniells?, as per the Designation Report)

FORGIONE RESIDENCE
108 SHORE ROAD
 DOUGLASTON, NY 11363
DADRAS ARCHITECTS
 234-21 41ST AVENUE
 DOUGLASTON, NY 11363
 212 239-8293

NYC-LANDMARKS PRESERVATION COMMISSION
 SUBMISSION DATE:08/31/22

Detail View: DOF: Queens 1980s Tax Photos: dof_4_08040_0001

108 SHORE ROAD (SE corner of Shore Road and Hollywood Avenue)
aka 235-02--235-12 Hollywood Avenue; 34-01--34-05 Shore Road

Borough of Queens Tax Map Block 8040, lot 1

Douglas Manor Section One, Block 11, lots 6-10

BIN: 4168244

Date: 1920

Architect: A.P. Wohlpart

Original Owner: A.L. Daniells

Type: Freestanding house with attached garage

Style: Colonial Revival

Stories: 2½

Structure/material: Frame with brick veneer and wood shingle siding

Notable building features: Gable roof, with overhang in front, decorative fascia and eave returns; exposed brick chimney, white-washed; panelled entryway with shutters and flanking lanterns; brick stoop; quarter-round windows flanking chimney; second-story balcony; windows with historic multi-pane sash and shutters.

Alterations: Projecting bays on first story with steel casements; through-the-wall air conditioning unit; replacement ironwork on second-story balcony.

Related structure on lot: Matching two-car garage, entered from Hollywood Avenue, attached to the house by an enclosed porch; replacement vehicle door; contemporary with the house.

Notable site features: Mature trees; stepped flagstone walkway with wrought-iron railings (Hollywood Avenue); lamp post; cobblestone curb (Shore Road).

Photos: 4 views



Identifier:	dof_4_08040_0001
Date:	1983-1988
Borough:	4 (Queens)
Block:	8040
Lot:	1
Building Number:	3405
Street Name:	SHORE ROAD
Zip Code:	11106
LVD Frame:	lvd_16_50092
Tax Class:	1) 1-3 Unit Residences
Owner (In 1990):	R. KUSSIN
Lot Frontage:	1.12
Lot Depth:	1
Year Built:	1930 (Estimated)

INCORRECT INFORMATION contained in the DESIGNATION REPORT of 1997

INCORRECT INFORMATION contained in the TAX PHOTO of 1980s, *because there is NO TAX PHOTO from 1940s??

FORGIONE RESIDENCE

108 SHORE ROAD

DOUGLASTON, NY 11363

DADRAS ARCHITECTS

234-21 41ST AVENUE

DOUGLASTON, NY 11363

212 239-8293

NYC-LANDMARKS PRESERVATION COMMISSION

SUBMISSION DATE:08/31/22

1/23/17 (14)

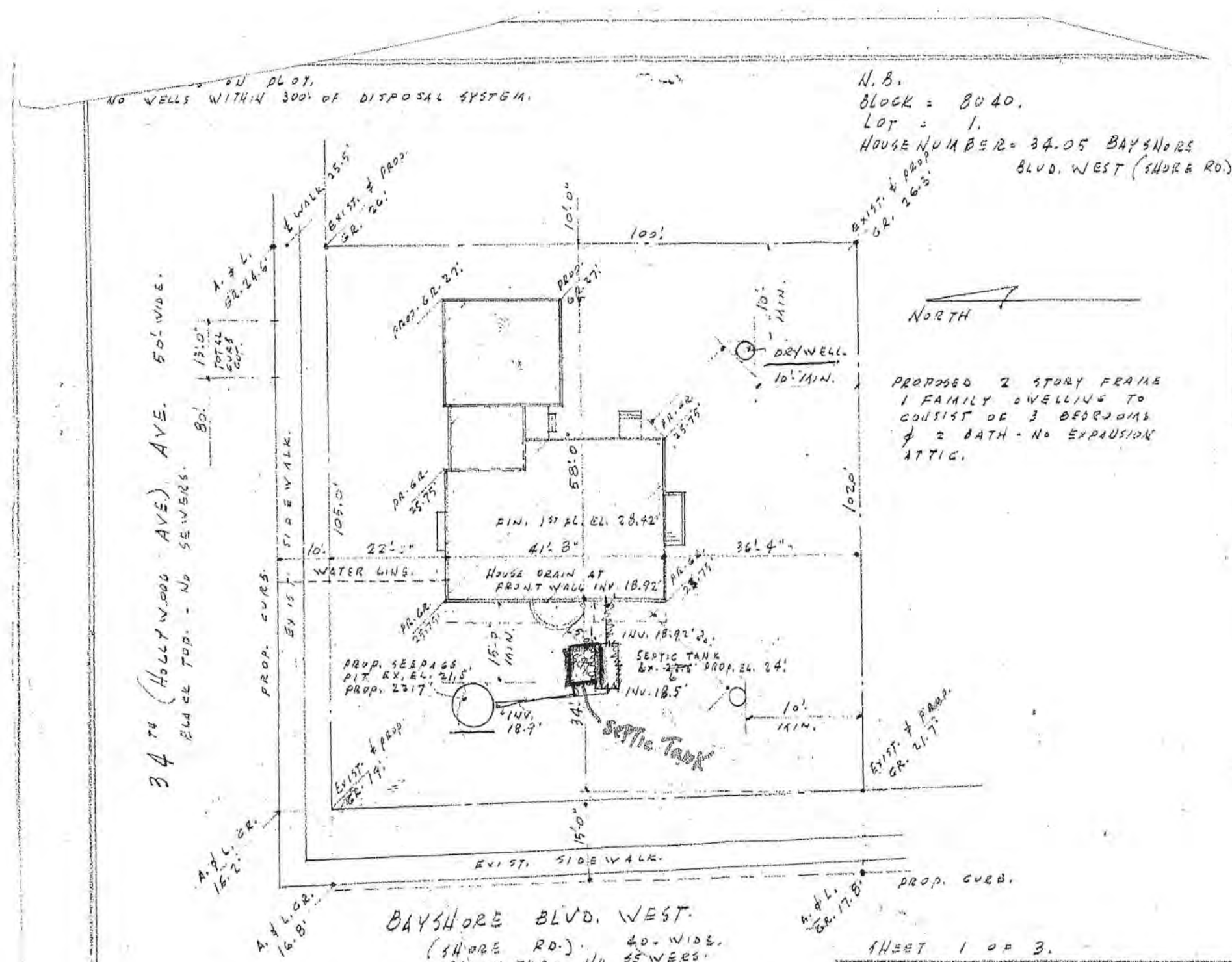

1/20/17
Return
to
Envelop

1955
PLOT
LAYOUT

PLOT PLAN
1" = 20'-0"

OWNER - MR. KENNETH E. LYNCH.
32 ORIENT AVE.
DOUGLASS, N.Y.

SIGNED: *Carl H. Salminen*
CARL H. SALMINEN, ARCHITECT.



SHEET 1 OF 3.

CARL H. SALMINEN, A. I. A.
ARCHITECT
ARCHITECTS

R. M. O. BOECKL... FLUSHING, N. Y.

DRAWN BY	EIL.	CHECKED BY	CHS.
SCALE	1" = 20'	JOB No. 55-19	
DATE	3-28-55.		

FORGIONE RESIDENCE
108 SHORE ROAD
DOUGLASS, NY 11363

DADRAS ARCHITECTS
234-21 41ST AVENUE
DOUGLASS, NY 11363
212 239-8293

NYC-LANDMARKS PRESERVATION COMMISSION
SUBMISSION DATE: 08/31/22

60 4 16

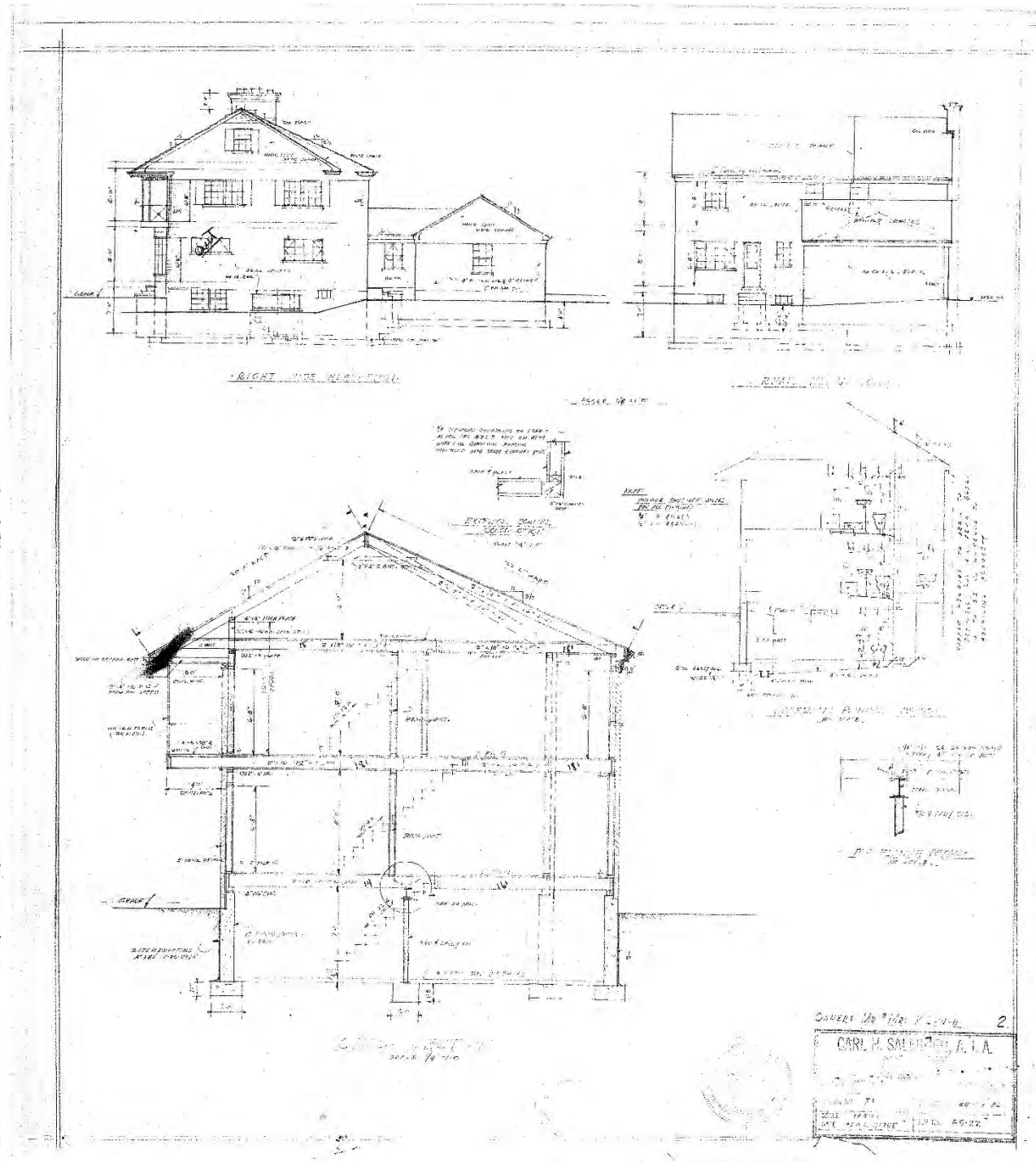

FORGIONE RESIDENCE

108 SHORE ROAD

DOUGLASTON, NY 11363

DADRAS ARCHITECTS

234-21 41ST AVENUE
DOUGLASTON, NY 11363
212 239-8293

NYC-LANDMARKS PRESERVATION COMMISSION

SUBMISSION DATE: 08/31/22

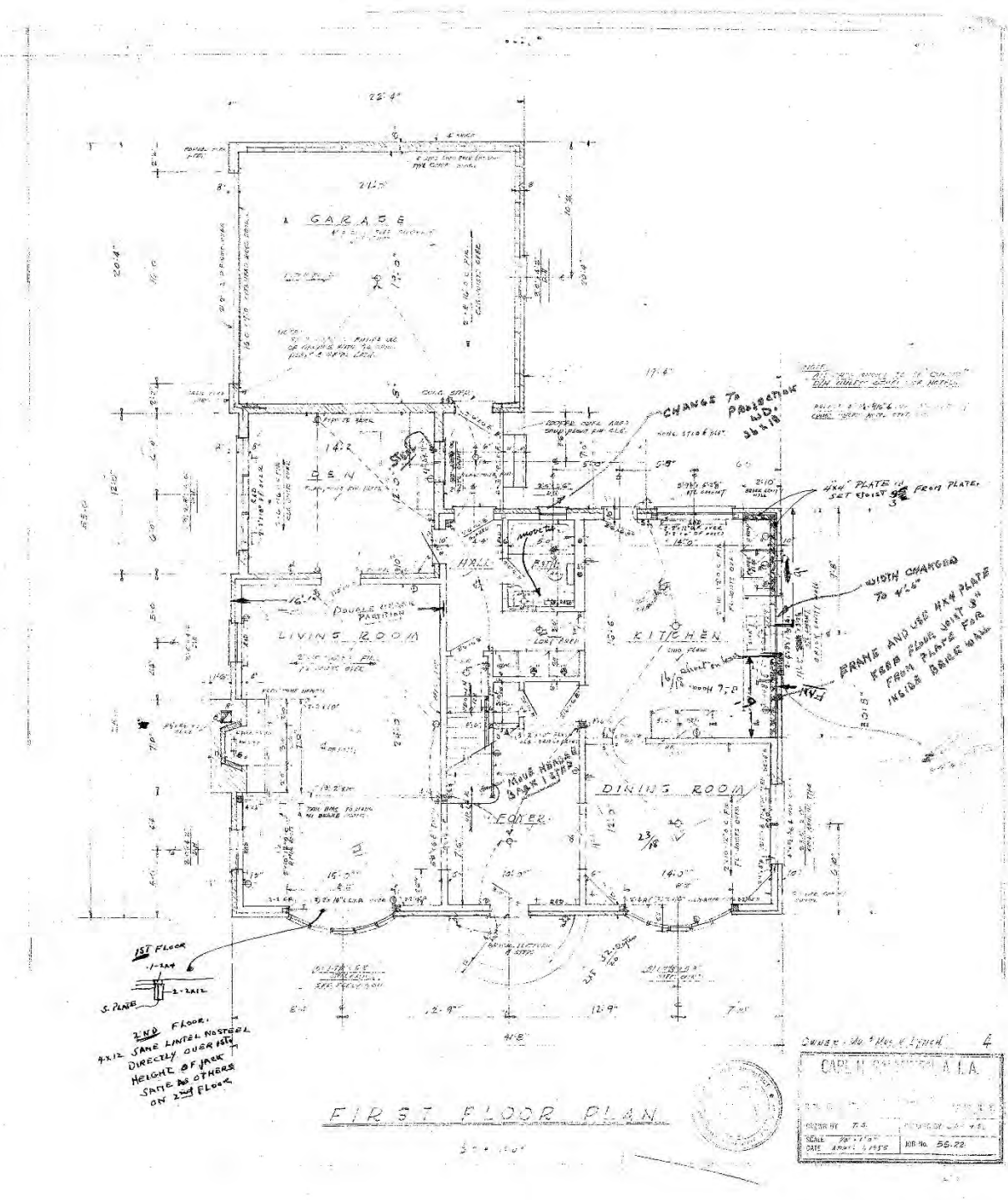
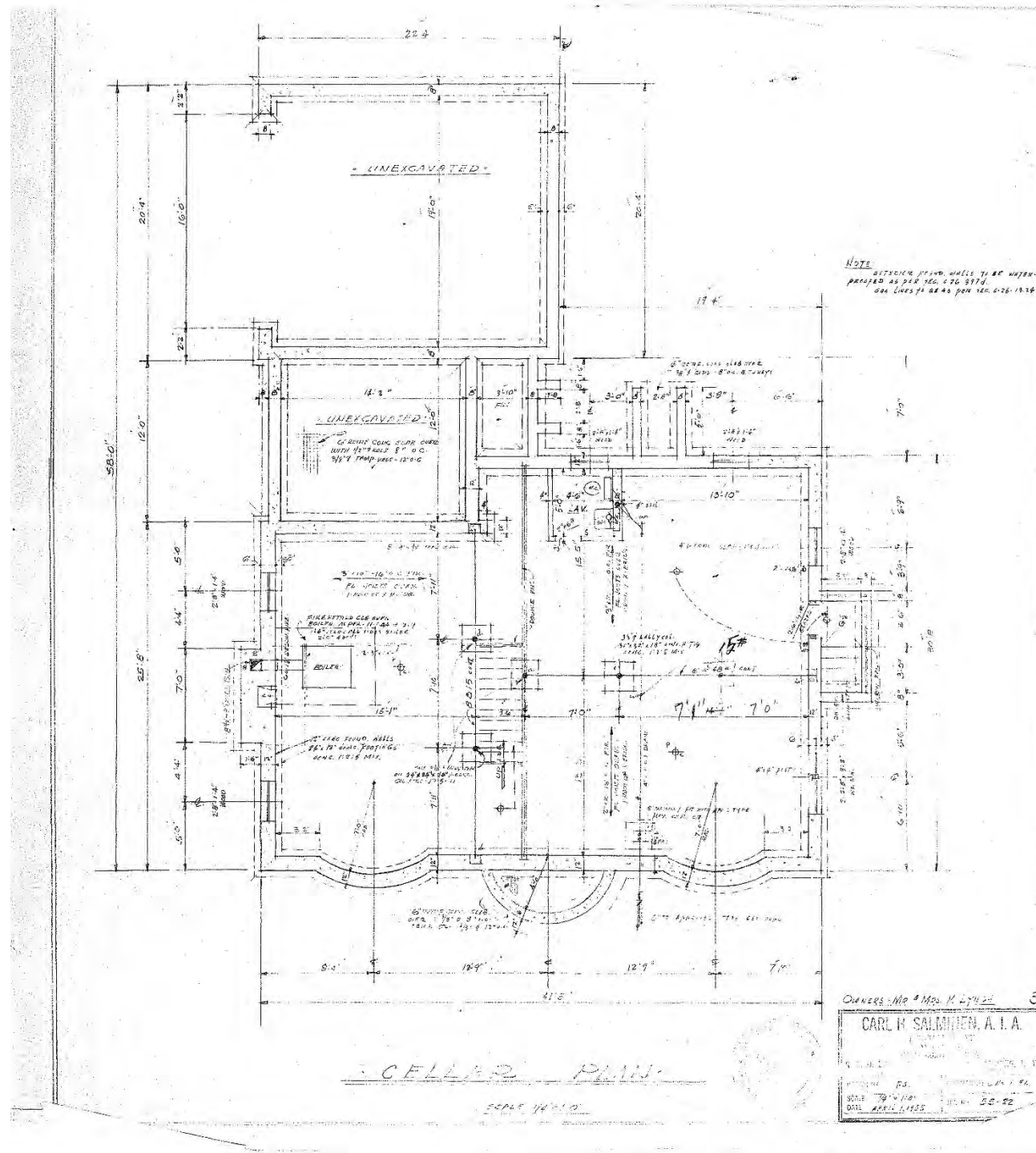

FORGIONE RESIDENCE

108 SHORE ROAD

DOUGLSTON, NY 11363

DADRAS ARCHITECTS

234-21 41ST AVENUE

DOUGLSTON, NY 11363

212 239-8293

NYC-LANDMARKS PRESERVATION COMMISSION

SUBMISSION DATE: 08/31/22



**DOUGLAS MANOR Sanborn
Corrected 1933 MAP**

FORGIONE RESIDENCE
108 SHORE ROAD
DOUGLASTON, NY 11363

DADRAS ARCHITECTS
234-21 41ST AVENUE
DOUGLASTON, NY 11363
212 239-8293

NYC-LANDMARKS PRESERVATION COMMISSION
SUBMISSION DATE:08/31/22



<https://1940s.nyc/map/photo/>



FORGIONE RESIDENCE

108 SHORE ROAD

DOUGLASTON, NY 11363

DADRAS ARCHITECTS

234-21 41ST AVENUE
DOUGLASTON, NY 11363
212 239-8293

NYC-LANDMARKS PRESERVATION COMMISSION

SUBMISSION DATE:08/31/22



01

108 SHORE ROAD



02

108 SHORE ROAD



03

102 SHORE ROAD



04

202 SHORE ROAD



05

202 SHORE ROAD



06

6 HOLLYWOOD AVENUE



07

7 HOLLYWOOD AVENUE

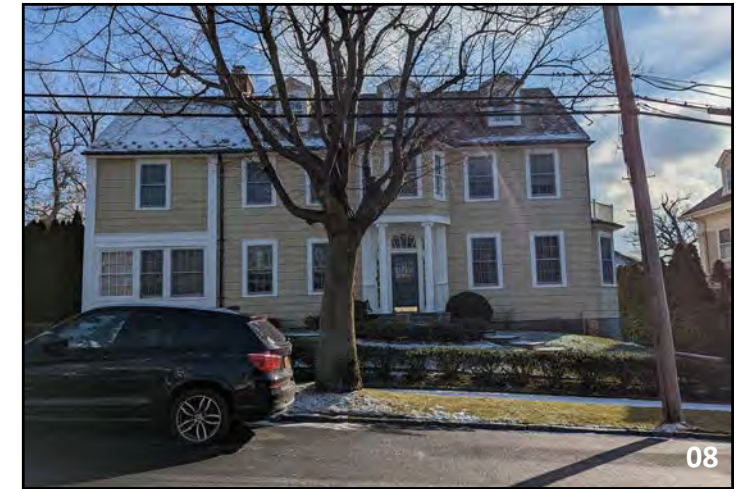

08

EXISTING PROJECT SITE



09

17 HOLLYWOOD AVENUE



10

101 HOLLYWOOD AVENUE



11

236-02 MANOR AVENUE

FORGIONE RESIDENCE

108 SHORE ROAD

DOUGLSTON, NY 11363

DADRAS ARCHITECTS

234-21 41ST AVENUE

DOUGLSTON, NY 11363

212 239-8293

NYC-LANDMARKS PRESERVATION COMMISSION

SUBMISSION DATE:08/31/22



207 SHORE ROAD



304 SHORE ROAD



310 SHORE ROAD



28 SHORE ROAD



15 SHORE ROAD



18 SHORE ROAD

FORGIONE RESIDENCE

108 SHORE ROAD

DOUGLASTON, NY 11363

DADRAS ARCHITECTS

234-21 41ST AVENUE
DOUGLASTON, NY 11363
212 239-8293

NYC-LANDMARKS PRESERVATION COMMISSION

SUBMISSION DATE:08/31/22



6 KNOLLWOOD AVENUE



321 HOLLYWOOD AVENUE

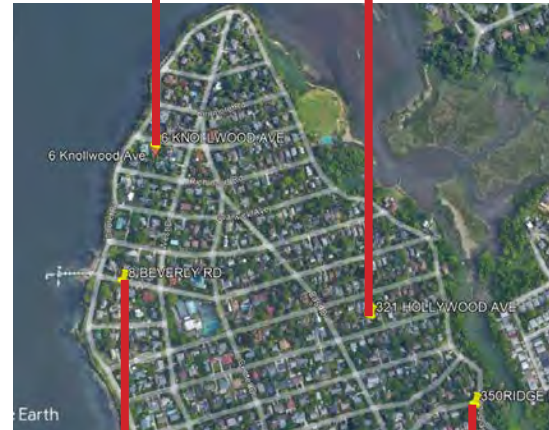

8 BEVERLY ROAD



350 RIDGE ROAD

HOUSES BUILT AFTER 1945

FORGIONE RESIDENCE

108 SHORE ROAD

DOUGLASTON, NY 11363

DADRAS ARCHITECTS

234-21 41ST AVENUE
DOUGLASTON, NY 11363
212 239-8293

NYC-LANDMARKS PRESERVATION COMMISSION

SUBMISSION DATE:08/31/22



3 MELROSE LANE



8 SHORE RD



10 RICHMOND ROAD

FORGIONE RESIDENCE

108 SHORE ROAD

DOUGLASTON, NY 11363

DADRAS ARCHITECTS

234-21 41ST AVENUE
DOUGLASTON, NY 11363
212 239-8293

NYC-LANDMARKS PRESERVATION COMMISSION

SUBMISSION DATE:08/31/22

NON-CONTRIBUTING HOUSES BUILT AFTER 1945



18 SHORE ROAD



359 MANOR ROAD



360 PARK LANE

FORGIONE RESIDENCE

108 SHORE ROAD

DOUGLASTON, NY 11363

DADRAS ARCHITECTS

234-21 41ST AVENUE
DOUGLASTON, NY 11363
212 239-8293

NON-CONTRIBUTING HOUSES BUILT AFTER 1945

NYC-LANDMARKS PRESERVATION COMMISSION
SUBMISSION DATE:08/31/22



FRONT PHOTO - WEST ELEVATION



FORGIONE RESIDENCE

108 SHORE ROAD

DOUGLASTON, NY 11363

DADRAS ARCHITECTS

234-21 41ST AVENUE
DOUGLASTON, NY 11363
212 239-8293

NYC-LANDMARKS PRESERVATION COMMISSION

SUBMISSION DATE:08/31/22



SIDE PHOTO - NORTH ELEVATION



FORGIONE RESIDENCE

108 SHORE ROAD

DOUGLASTON, NY 11363

DADRAS ARCHITECTS

234-21 41ST AVENUE

DOUGLASTON, NY 11363

212 239-8293

NYC-LANDMARKS PRESERVATION COMMISSION

SUBMISSION DATE:08/31/22



SIDE PHOTO - SOUTH ELEVATION



FORGIONE RESIDENCE

108 SHORE ROAD

DOUGLASTON, NY 11363

DADRAS ARCHITECTS

234-21 41ST AVENUE

DOUGLASTON, NY 11363

212 239-8293

NYC-LANDMARKS PRESERVATION COMMISSION

SUBMISSION DATE:08/31/22



REAR PHOTO - EAST ELEVATION



FORGIONE RESIDENCE

108 SHORE ROAD

DOUGLASTON, NY 11363

DADRAS ARCHITECTS

234-21 41ST AVENUE

DOUGLASTON, NY 11363

212 239-8293

NYC-LANDMARKS PRESERVATION COMMISSION

SUBMISSION DATE:08/31/22



CHIMNEY

*KEPT IN PROPOSED PLAN



SECOND STORY BALCONY

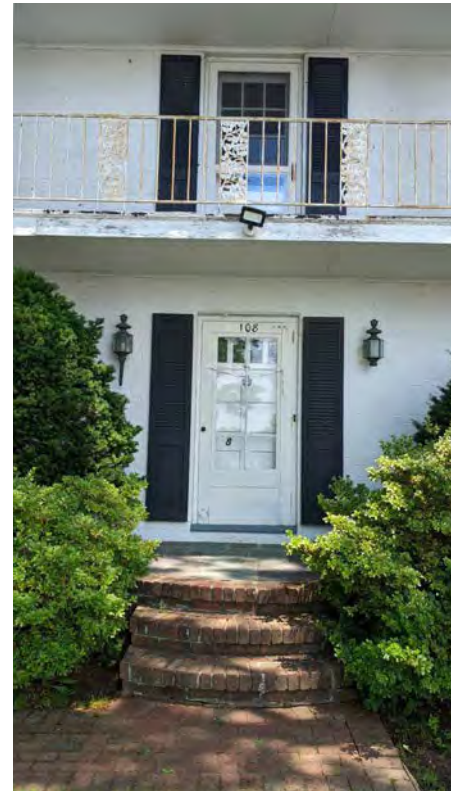

SECOND STORY BALCONY
ENTRYWAY WITH SHUTTERS
AND FLANKING LANTERS



STEPPED FLAGSTONE
WALKWAY

*KEPT IN PROPOSED PLAN



MATURE TREES - EAST SIDE

*KEPT IN PROPOSED PLAN



GARAGE

*KEPT IN PROPOSED PLAN



WINDOWS



MATURE TREES - SOUTH SIDE

*KEPT IN PROPOSED PLAN



MATURE TREES *KEPT IN PROPOSED PLAN

DETAILS

FORGIONE RESIDENCE

108 SHORE ROAD

DOUGLASTON, NY 11363

DADRAS ARCHITECTS

234-21 41ST AVENUE



DOUGLASTON, NY 11363

212 239-8293

NYC-LANDMARKS PRESERVATION COMMISSION

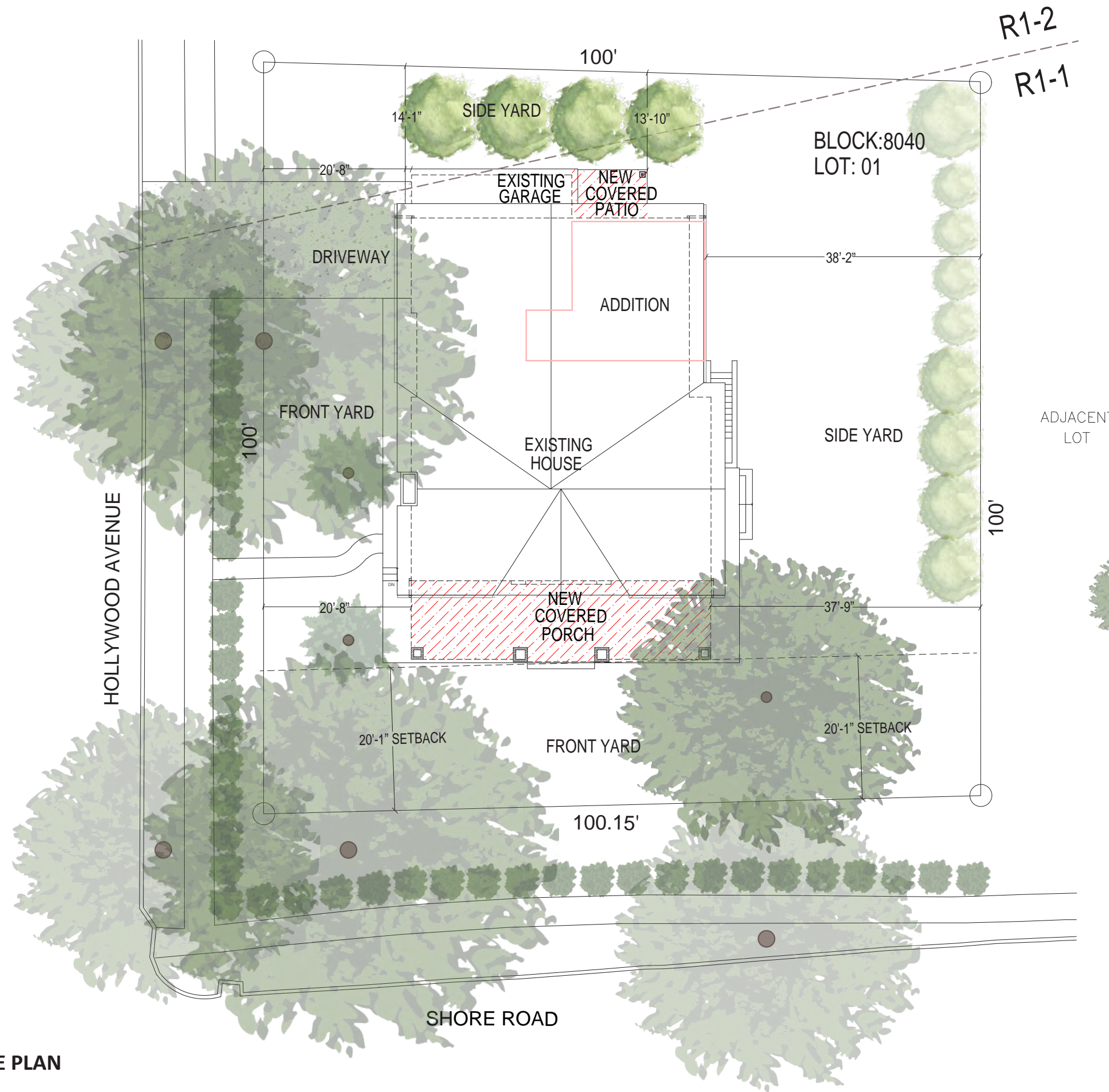
SUBMISSION DATE:08/31/22

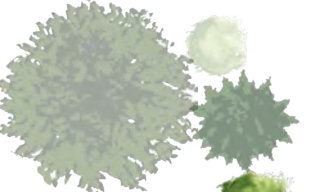

-  PROPOSED EVERGREENS ALONG HOLLYWOOD AVENUE AND SHORE ROAD
-  EXISTING TO REMAIN
-  20-FOOT-HIGH LINE OF TREES ON EAST SIDE TO BE PROTECTED FROM DAMAGE DURING CONSTRUCTION
-  TREE TRUNK ESTIMATED LOCATION ON SITE

FORGIONE RESIDENCE

108 SHORE ROAD

DOUGLASTON, NY 11363

DADRAS ARCHITECTS

234-21 41ST AVENUE
DOUGLASTON, NY 11363
212 239-8293

NYC-LANDMARKS PRESERVATION COMMISSION

SUBMISSION DATE:08/31/22



1 PROJECT SITE
 BLOCK 8040 LOT 1
 AREA 10,200 sq.ft

EXISTING
 FOOTPRINT 2,605 sq.ft
 COVERAGE 25.5%

PROPOSED
 FOOTPRINT 2,744 sq.ft
 COVERAGE 26.9%

2
 BLOCK 8040 LOT 6
 AREA 9,000 sq ft
 FOOTPRINT 4,600 sq.ft
 COVERAGE 51%

3
 BLOCK 8040 LOT 11
 AREA 9,000 sq ft
 FOOTPRINT 4,240 sq.ft
 COVERAGE 47%

4
 BLOCK 8040 LOT 68
 AREA 13,000 sq ft
 FOOTPRINT 2,851 sq.ft
 COVERAGE 22%

5
 BLOCK 8040 LOT 64
 AREA 8,000 sq ft
 FOOTPRINT 3,500 sq.ft
 COVERAGE 44%

6
 BLOCK 8040 LOT 59
 AREA 10,100 sq ft
 FOOTPRINT 4,200 sq.ft
 COVERAGE 42%

7
 BLOCK 8038 LOT 1
 AREA 10,000 sq ft
 FOOTPRINT 1,992 sq.ft
 COVERAGE 20%

8
 BLOCK 8038 LOT 6
 AREA 12,455 sq ft
 FOOTPRINT 3,832 sq.ft
 COVERAGE 31%

9
 BLOCK 8038 LOT 12
 AREA 14,300 sq ft
 FOOTPRINT 4,381 sq.ft
 COVERAGE 31%

10
 BLOCK 8038 LOT 69
 AREA 8,675 sq ft
 FOOTPRINT 4,136 sq.ft
 COVERAGE 42%

11
 BLOCK 8038 LOT 63
 AREA 12,000 sq ft
 FOOTPRINT 3,932 sq.ft
 COVERAGE 33%

12
 BLOCK 8038 LOT 58
 AREA 9,442 sq ft
 FOOTPRINT 3,864 sq.ft
 COVERAGE 41%

13
 BLOCK 8042 LOT 1
 AREA 10,000 sq ft
 FOOTPRINT 2,963 sq.ft
 COVERAGE 30%

14
 BLOCK 8042 LOT 6
 AREA 10,500 sq ft
 FOOTPRINT 3,865 sq.ft
 COVERAGE 37%

15
 BLOCK 8042 LOT 10
 AREA 10,100 sq ft
 FOOTPRINT 3,222 sq.ft
 COVERAGE 32%

16
 BLOCK 8042 LOT 63
 AREA 9,200 sq ft
 FOOTPRINT 2,656 sq.ft
 COVERAGE 29%

17
 BLOCK 8042 LOT 58
 AREA 14,600 sq ft
 FOOTPRINT 1,801 sq.ft
 COVERAGE 12%

- EXISTING PROJECT SITE
- PROPOSED PROJECT ADDITION/ EXTENSION

FORGIONE RESIDENCE

108 SHORE ROAD

DOUGLASTON, NY 11363

DADRAS ARCHITECTS

234-21 41ST AVENUE
 DOUGLASTON, NY 11363
 212 239-8293

NYC-LANDMARKS PRESERVATION COMMISSION
 SUBMISSION DATE:08/31/22

SOURCE: <https://zola.planning.nyc.gov/>

NEIGHBORHOOD SQ.FT. PLAN

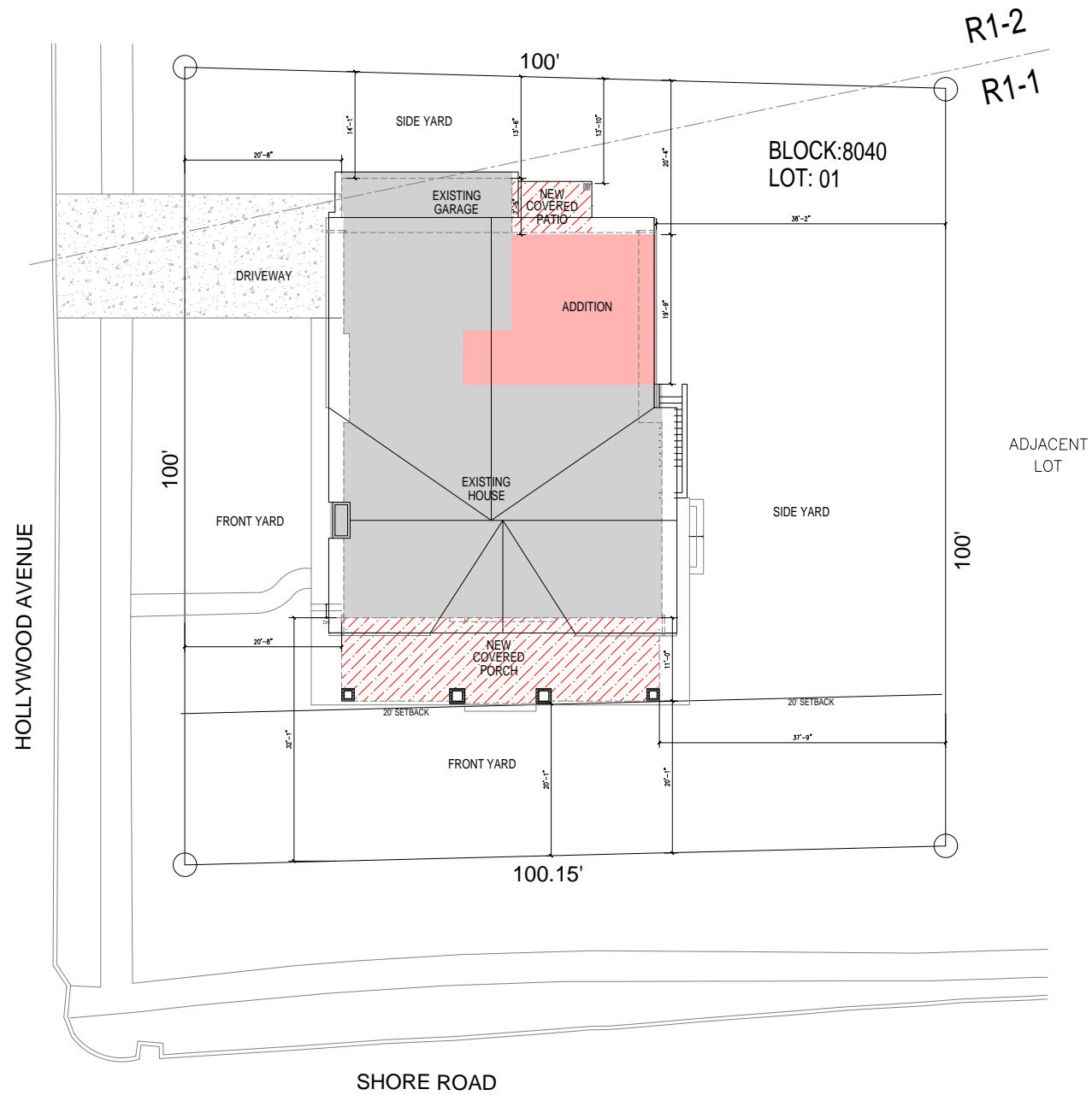
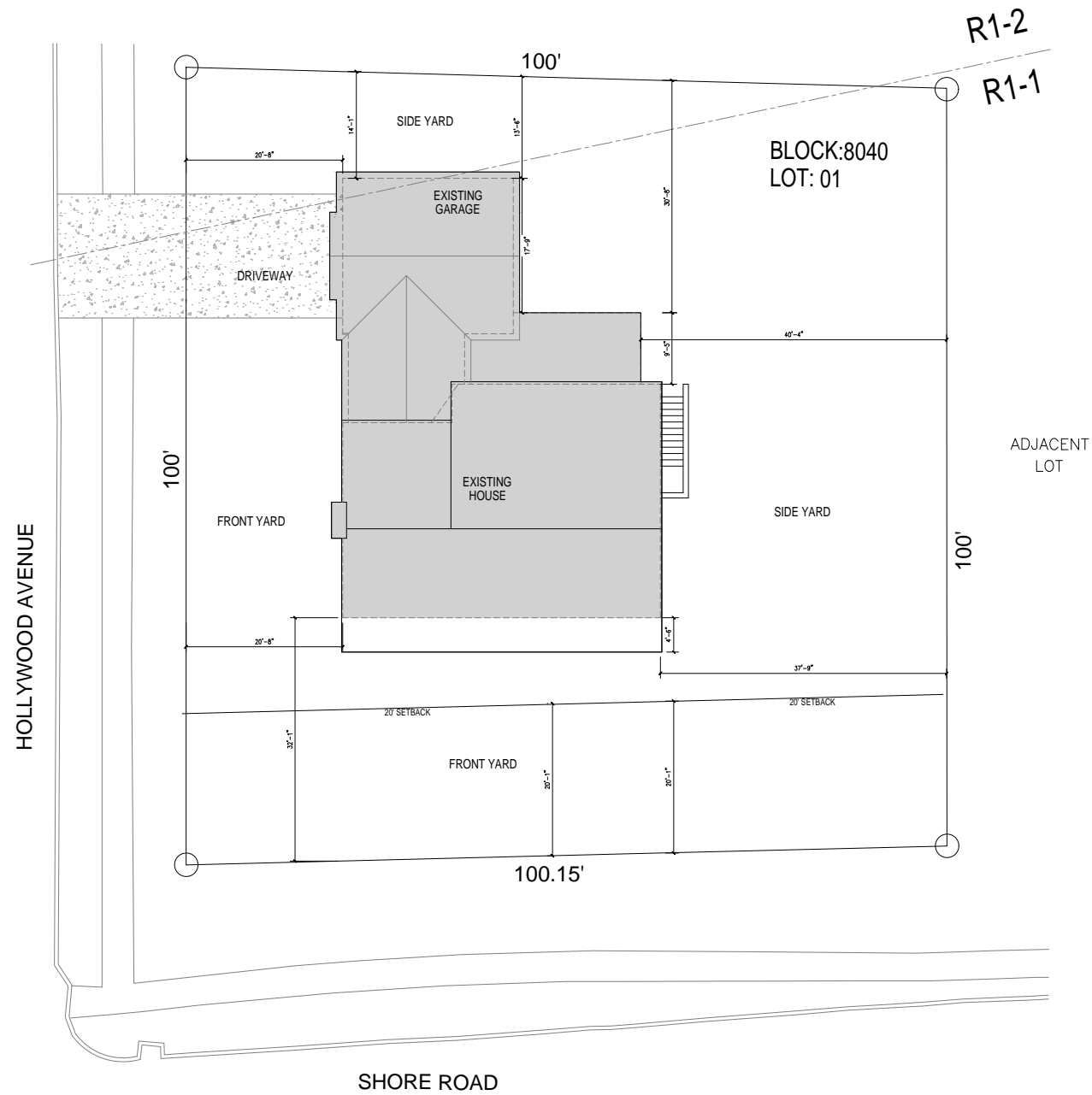

EXISTING PROJECT SITE PLAN

PROPOSED PROJECT SITE PLAN

- EXISTING PROJECT SITE
- PROPOSED ADDITION
- PROPOSED COVERED PORCH

FORGIONE RESIDENCE

108 SHORE ROAD

DOUGLASTON, NY 11363

DADRAS ARCHITECTS

234-21 41ST AVENUE
DOUGLASTON, NY 11363
212 239-8293

NYC-LANDMARKS PRESERVATION COMMISSION

SUBMISSION DATE: 08/31/22

ZR12-10 -
CELLAR NOT FA
(NO CHANGE)

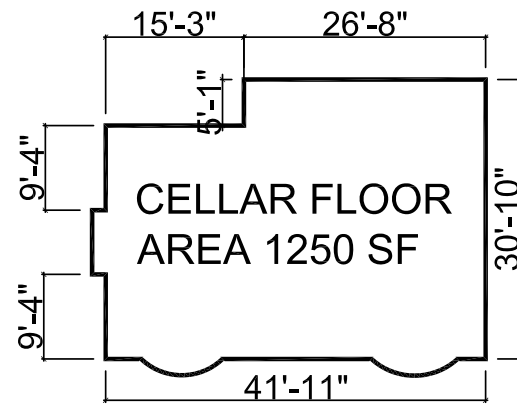

CELLAR PLAN

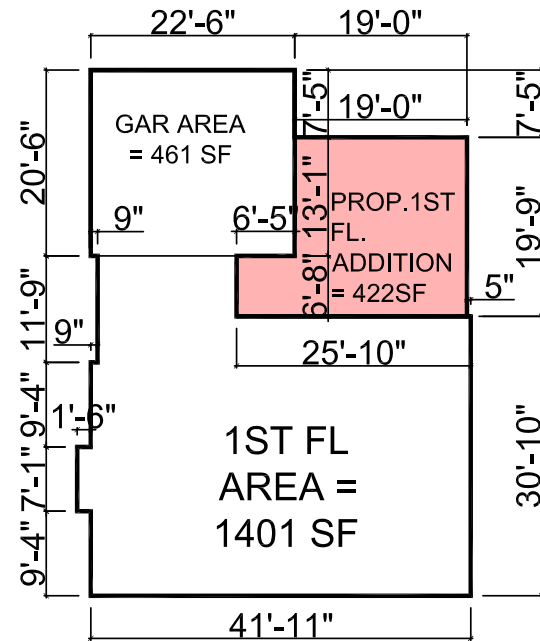

1ST FLOOR PLAN

AREA CALCULATIONS

Existing= 1,401 SF
Proposed Addition= 422 SF
Total proposed 1st Floor
1,823 SF (GROSS)

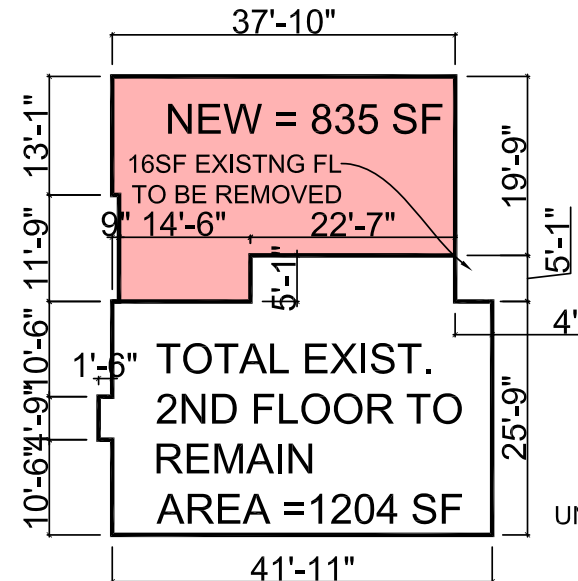

2ND FLOOR PLAN

AREA CALCULATIONS

Existing= 1,204 SF
Proposed Addition= 835 SF
Total proposed 2nd Floor
2,039 SF (GROSS)

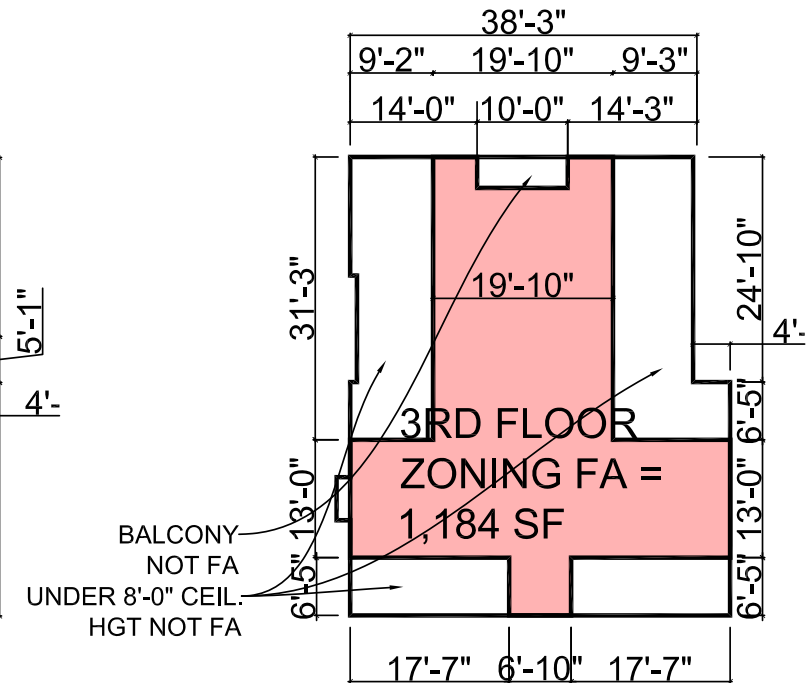

ATTIC FLOOR PLAN

AREA CALCULATIONS

Existing= 0 SF
Proposed Addition= 1,184 SF
Total proposed Attic Floor
1,184 SF (GROSS)

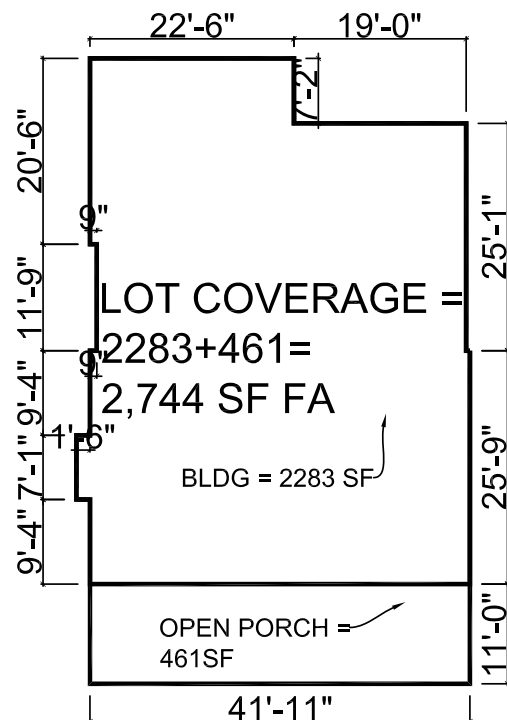

LOT COVERAGE

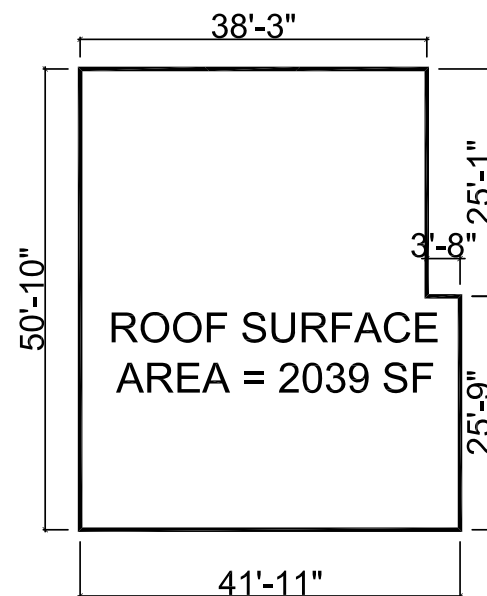

ROOF SURFACE AREA

FORGIONE RESIDENCE

108 SHORE ROAD

DOUGLASTON, NY 11363

DADRAS ARCHITECTS

234-21 41ST AVENUE
DOUGLASTON, NY 11363
212 239-8293

NYC-LANDMARKS PRESERVATION COMMISSION

SUBMISSION DATE:08/31/22

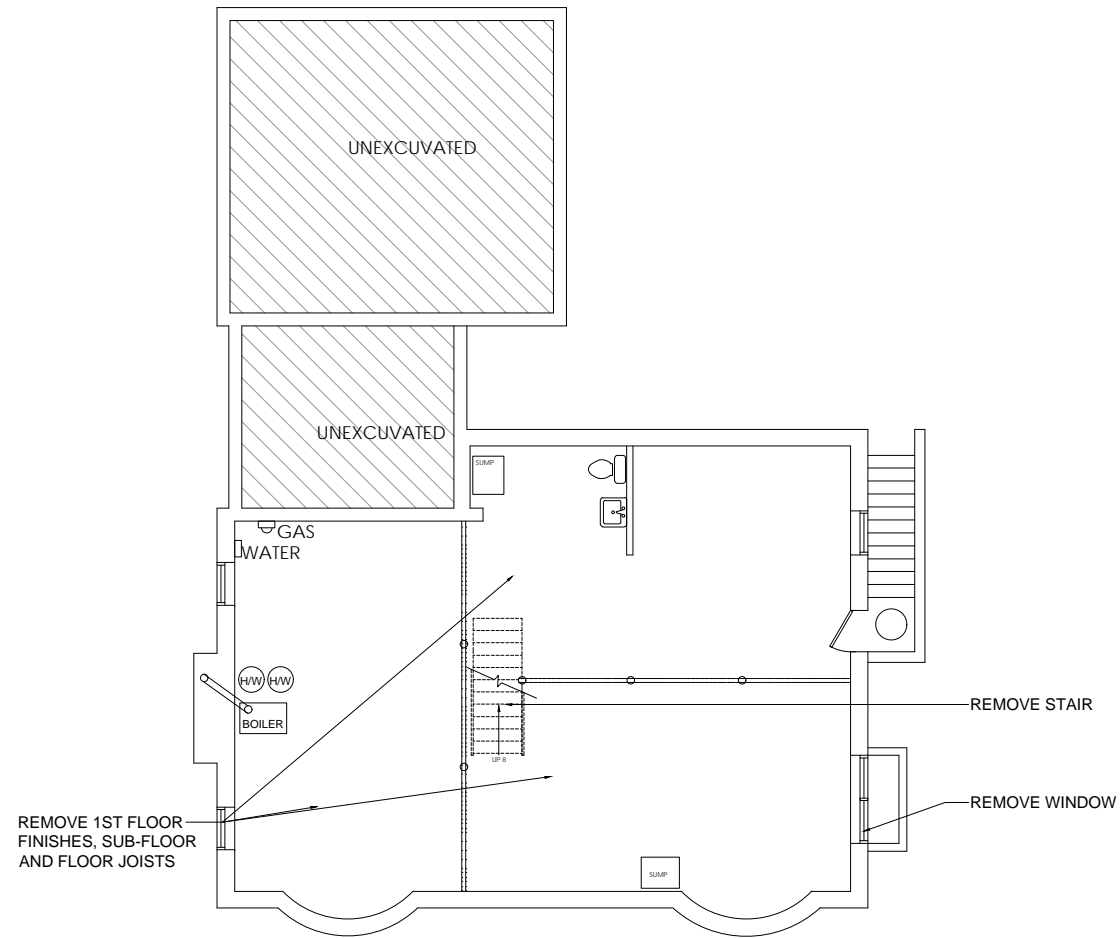

EXISTING CELLAR PLAN

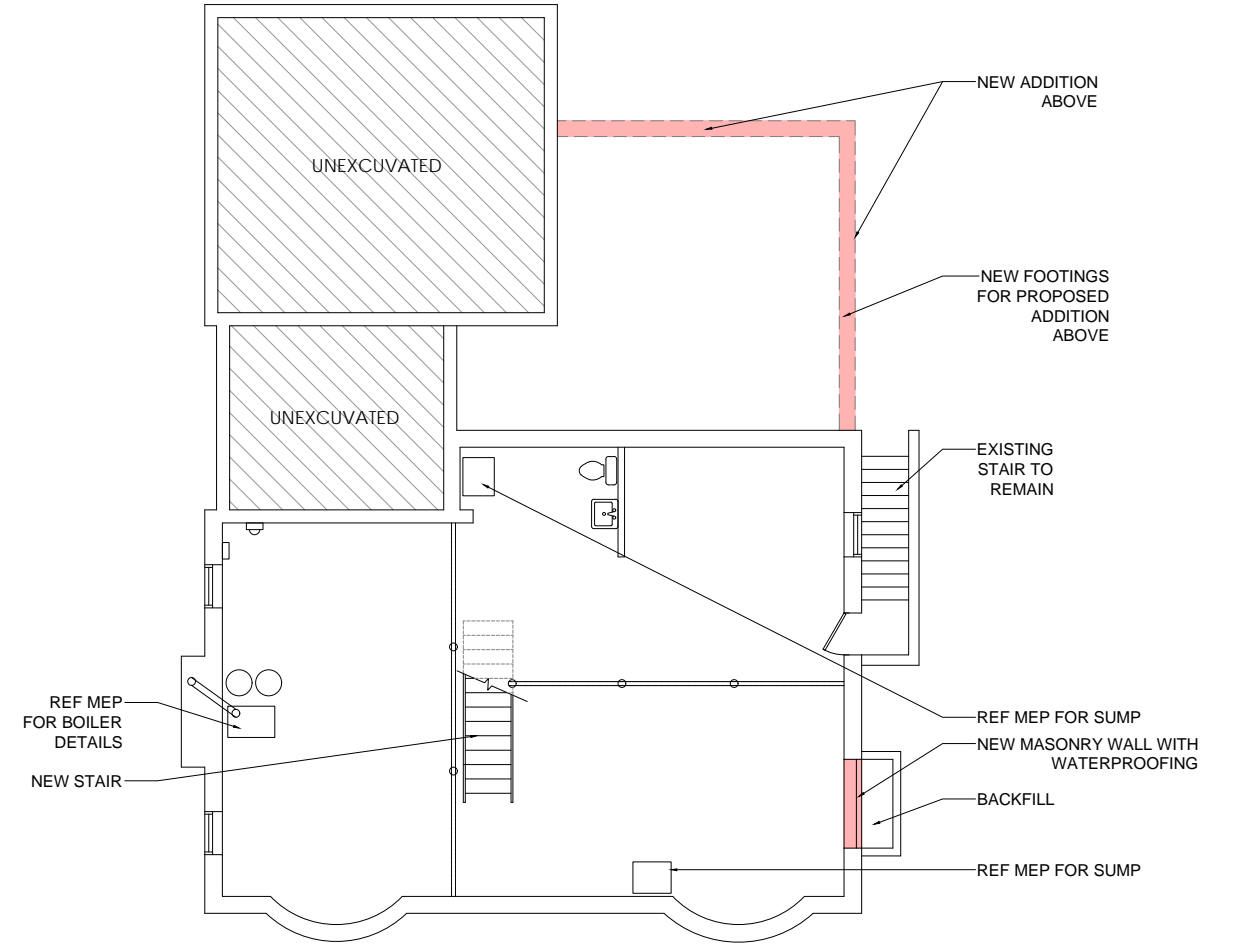

PROPOSED CELLAR PLAN

 PROPOSED EXTENT OF MINOR WORK

FORGIONE RESIDENCE

108 SHORE ROAD

DOUGLASTON, NY 11363

DADRAS ARCHITECTS

234-21 41ST AVENUE

DOUGLASTON, NY 11363

212 239-8293

NYC-LANDMARKS PRESERVATION COMMISSION

SUBMISSION DATE:08/31/22

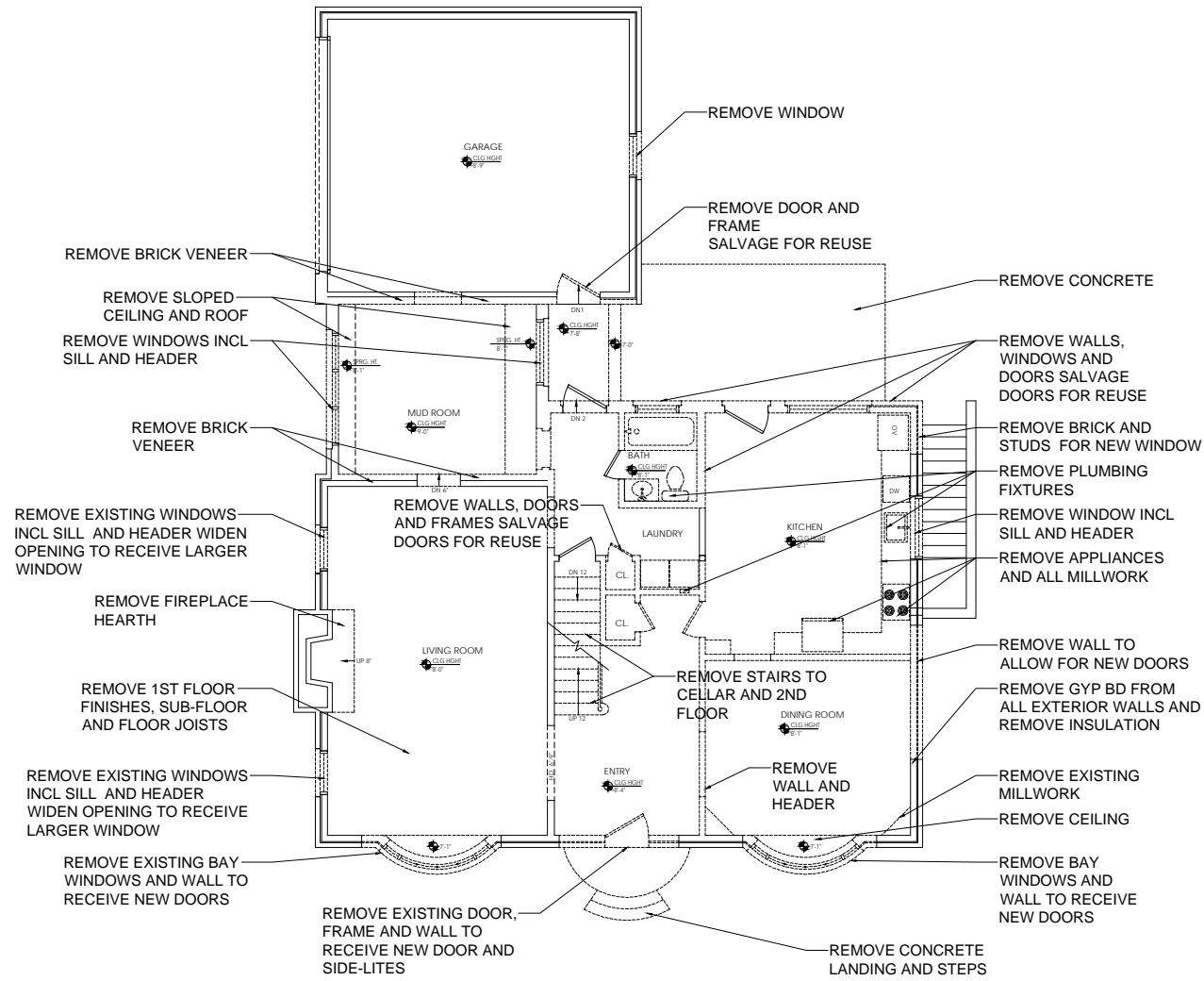

EXISTING 1ST FLOOR PLAN

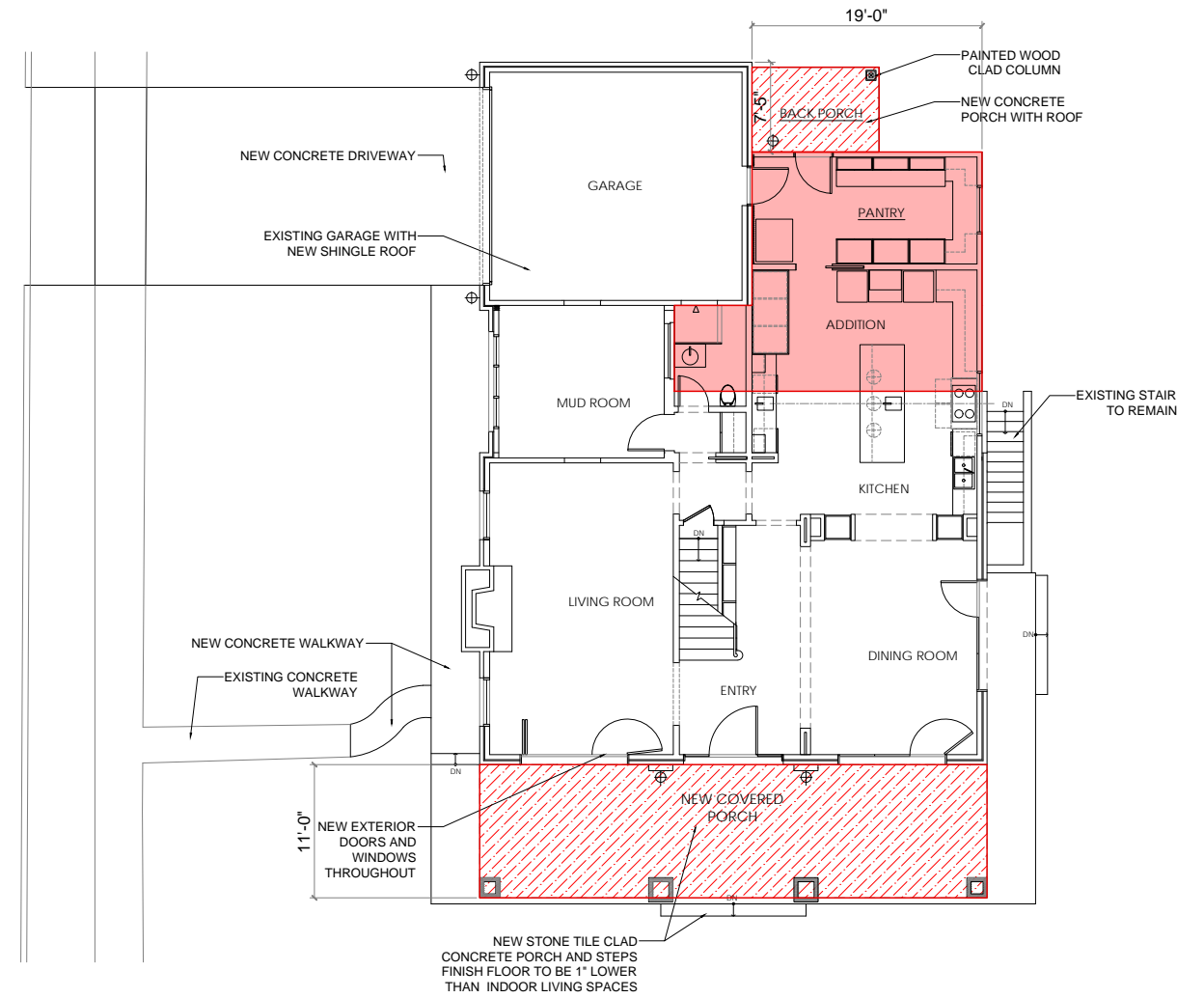

PROPOSED 1ST FLOOR PLAN

- PROPOSED EXTENT OF WORK
NEW ADDITION/ EXTENSION
- PROPOSED EXTENT OF MINOR WORK

AREA CALCULATIONS

Existing= 1,401 SF
Proposed Addition= 422 SF

Total proposed 1st Floor
1,823SF (GROSS)

FORGIONE RESIDENCE

108 SHORE ROAD

DOUGLSTON, NY 11363

DADRAS ARCHITECTS

234-21 41ST AVENUE
DOUGLSTON, NY 11363
212 239-8293

NYC-LANDMARKS PRESERVATION COMMISSION

SUBMISSION DATE:08/31/22

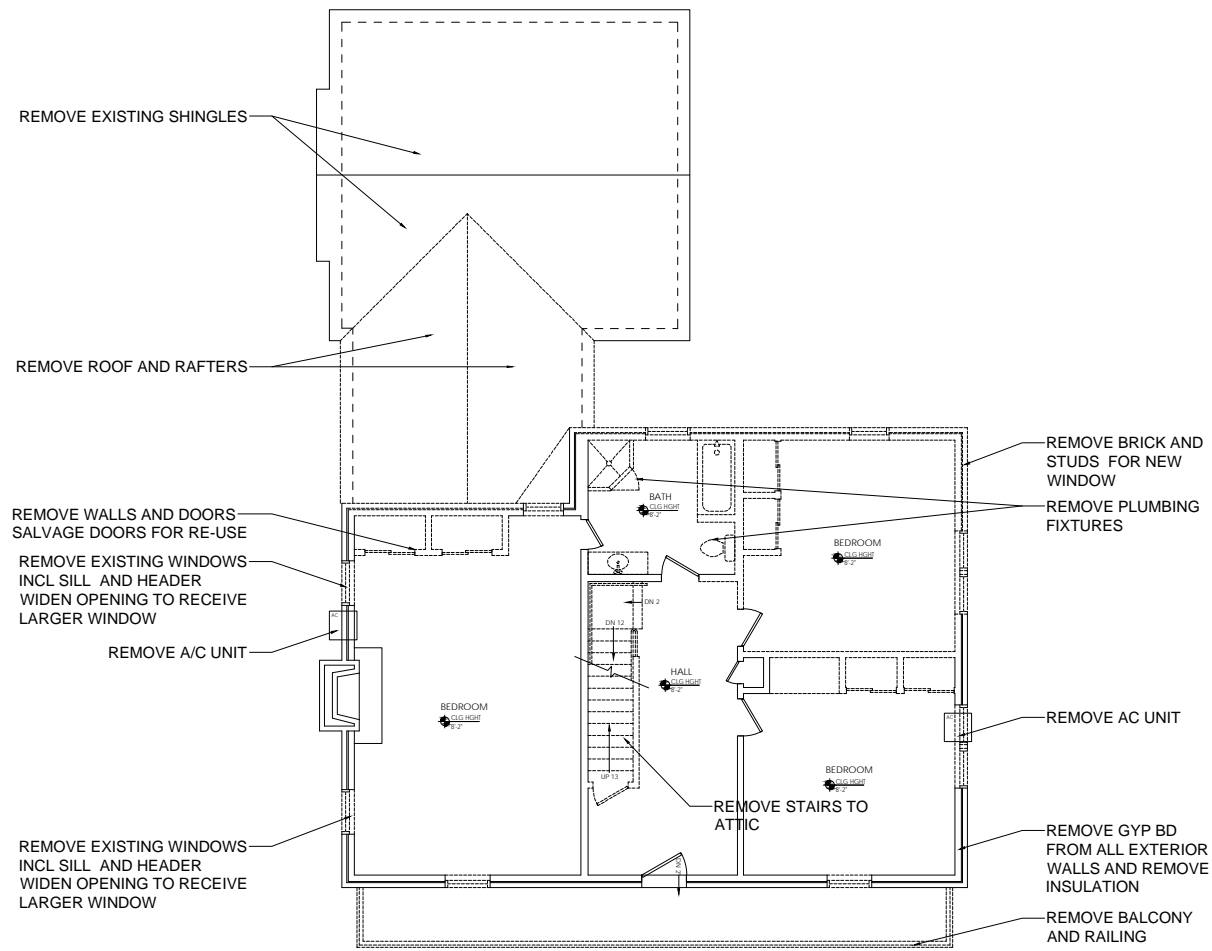

EXISTING 2ND FLOOR PLAN

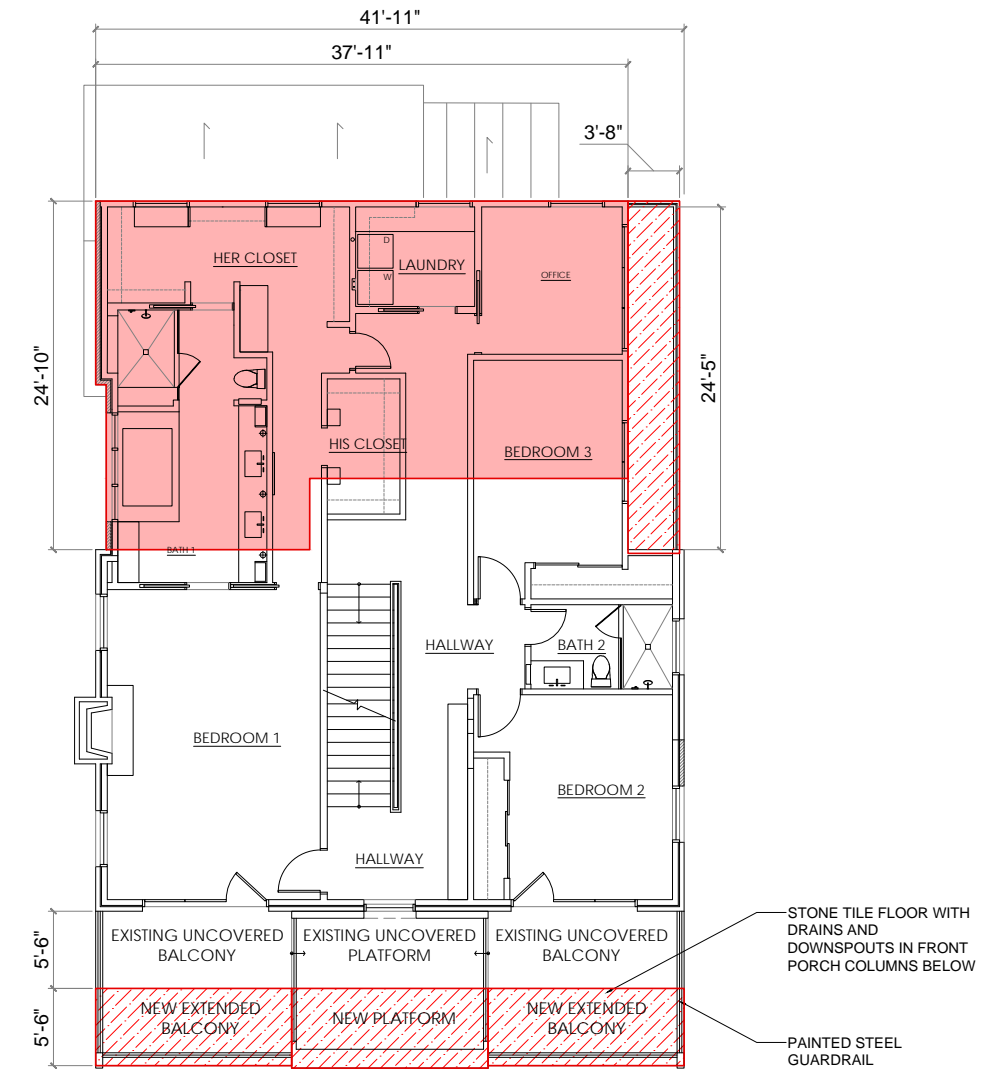

PROPOSED 2ND FLOOR PLAN

- PROPOSED EXTENT OF WORK
NEW ADDITION/ EXTENSION
- PROPOSED EXTENT OF MINOR WORK

AREA CALCULATIONS

Existing= 1,204 SF
Proposed Addition= 835 SF

Total proposed 2nd Floor
2,039 SF (GROSS)

FORGIONE RESIDENCE

108 SHORE ROAD

DOUGLSTON, NY 11363

DADRAS ARCHITECTS

234-21 41ST AVENUE
DOUGLSTON, NY 11363
212 239-8293

NYC-LANDMARKS PRESERVATION COMMISSION

SUBMISSION DATE:08/31/22

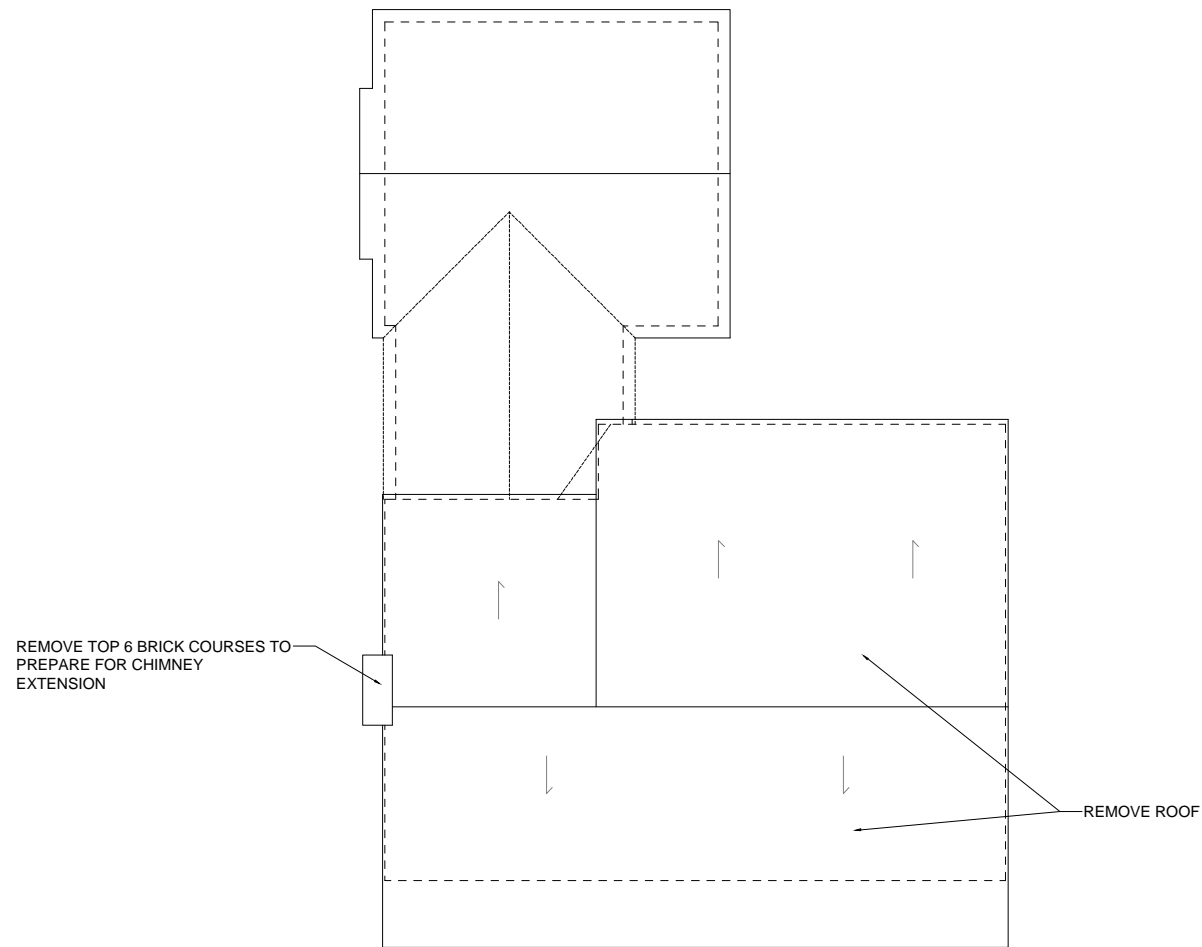

EXISTING ROOF FLOOR PLAN

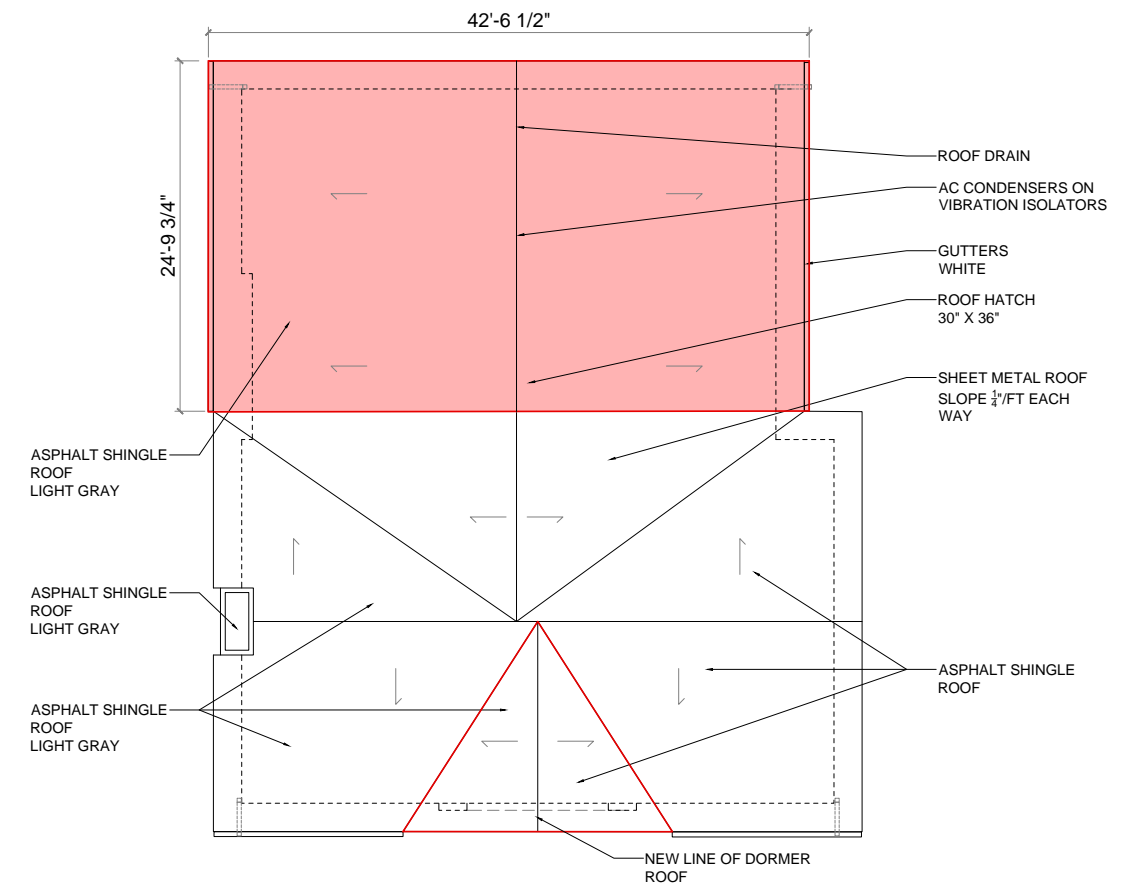

PROPOSED ROOF FLOOR PLAN

PROPOSED EXTENT OF WORK
NEW ADDITION/ EXTENSION

FORGIONE RESIDENCE

108 SHORE ROAD

DOUGLASTON, NY 11363

DADRAS ARCHITECTS

234-21 41ST AVENUE

DOUGLASTON, NY 11363

212 239-8293

NYC-LANDMARKS PRESERVATION COMMISSION

SUBMISSION DATE:08/31/22



EXISTING WEST ELEVATION



PROPOSED WEST ELEVATION

 PROPOSED EXTENT OF WORK
NEW ADDITION/ EXTENSION

FORGIONE RESIDENCE

108 SHORE ROAD

DOUGLASTON, NY 11363

DADRAS ARCHITECTS

234-21 41ST AVENUE
DOUGLASTON, NY 11363
212 239-8293

NYC-LANDMARKS PRESERVATION COMMISSION

SUBMISSION DATE:08/31/22



PROPOSED WEST MODEL

FORGIONE RESIDENCE

108 SHORE ROAD

DOUGLASTON, NY 11363

DADRAS ARCHITECTS

234-21 41ST AVENUE
DOUGLASTON, NY 11363
212 239-8293

NYC-LANDMARKS PRESERVATION COMMISSION

SUBMISSION DATE:08/31/22

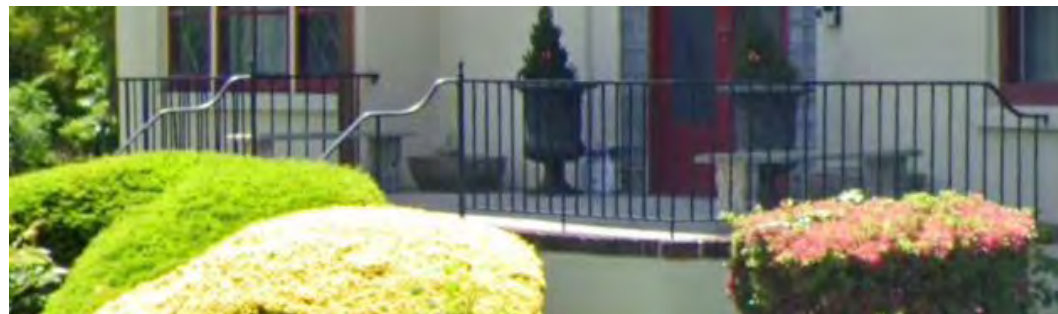

EXISTING NEIGHBORHOOD PHOTOS

METAL RAILINGS
STUCCO FINISH

REFERENCE
104 Knollwood Avenue,
Douglaston, NY

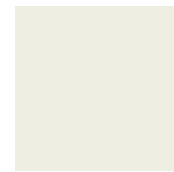

PAIN
BENJAMIN MOORE
Moonlight White



ROOF
Timberline HD Asphalt Shingle
Fox Hollow Gray



WALL FINISH
STUCCO Smooth finish



LANDSCAPING
Evergreens

EXTENT OF WORK WEST ELEVATION

FORGIONE RESIDENCE

108 SHORE ROAD

DOUGLASTON, NY 11363

DADRAS ARCHITECTS

234-21 41ST AVENUE
DOUGLASTON, NY 11363
212 239-8293

NYC-LANDMARKS PRESERVATION COMMISSION

SUBMISSION DATE:08/31/22



EXISTING SOUTH ELEVATION

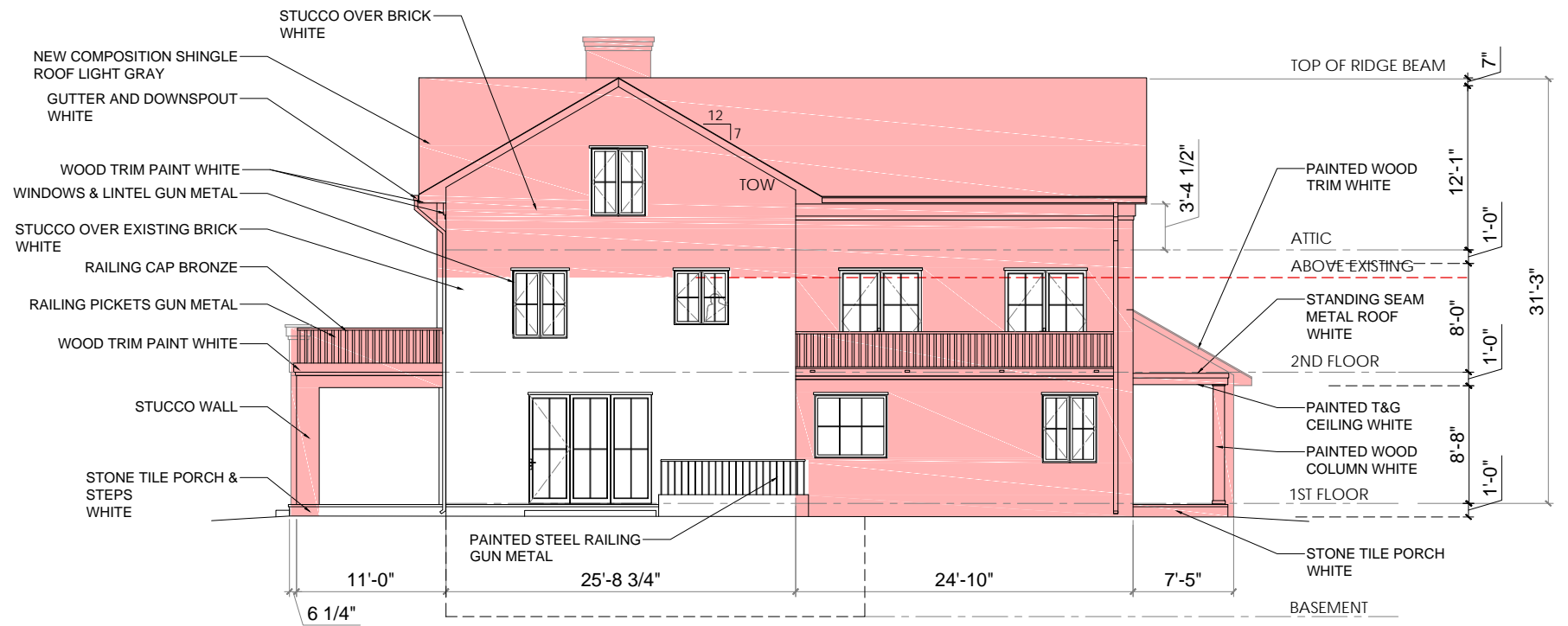

PROPOSED SOUTH ELEVATION

PROPOSED EXTENT OF WORK
NEW ADDITION/ EXTENSION

FORGIONE RESIDENCE

108 SHORE ROAD

DOUGLASTON, NY 11363

DADRAS ARCHITECTS

234-21 41ST AVENUE
DOUGLASTON, NY 11363
212 239-8293

NYC-LANDMARKS PRESERVATION COMMISSION

SUBMISSION DATE:08/31/22



PROPOSED SOUTH MODEL

FORGIONE RESIDENCE

108 SHORE ROAD

DOUGLASTON, NY 11363

DADRAS ARCHITECTS

234-21 41ST AVENUE

DOUGLASTON, NY 11363

212 239-8293

NYC-LANDMARKS PRESERVATION COMMISSION

SUBMISSION DATE:08/31/22

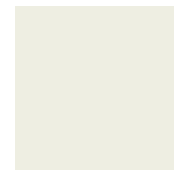

PAIN
 BENJAMIN MOORE
 Moonlight White



ROOF
 Timberline HD Asphalt Shingle
 Fox Hollow Gray



WALL FINISH
 STUCCO Smooth finish



LANDSCAPING
 Evergreens

EXISTING NEIGHBORHOOD PHOTOS

METAL RAILINGS

REFERENCE
 27-03 Shore Road,
 Douglaston, NY

EXTENT OF WORK SOUTH ELEVATION

FORGIONE RESIDENCE

108 SHORE ROAD

DOUGLASTON, NY 11363

DADRAS ARCHITECTS

234-21 41ST AVENUE
 DOUGLASTON, NY 11363
 212 239-8293

NYC-LANDMARKS PRESERVATION COMMISSION

SUBMISSION DATE:08/31/22

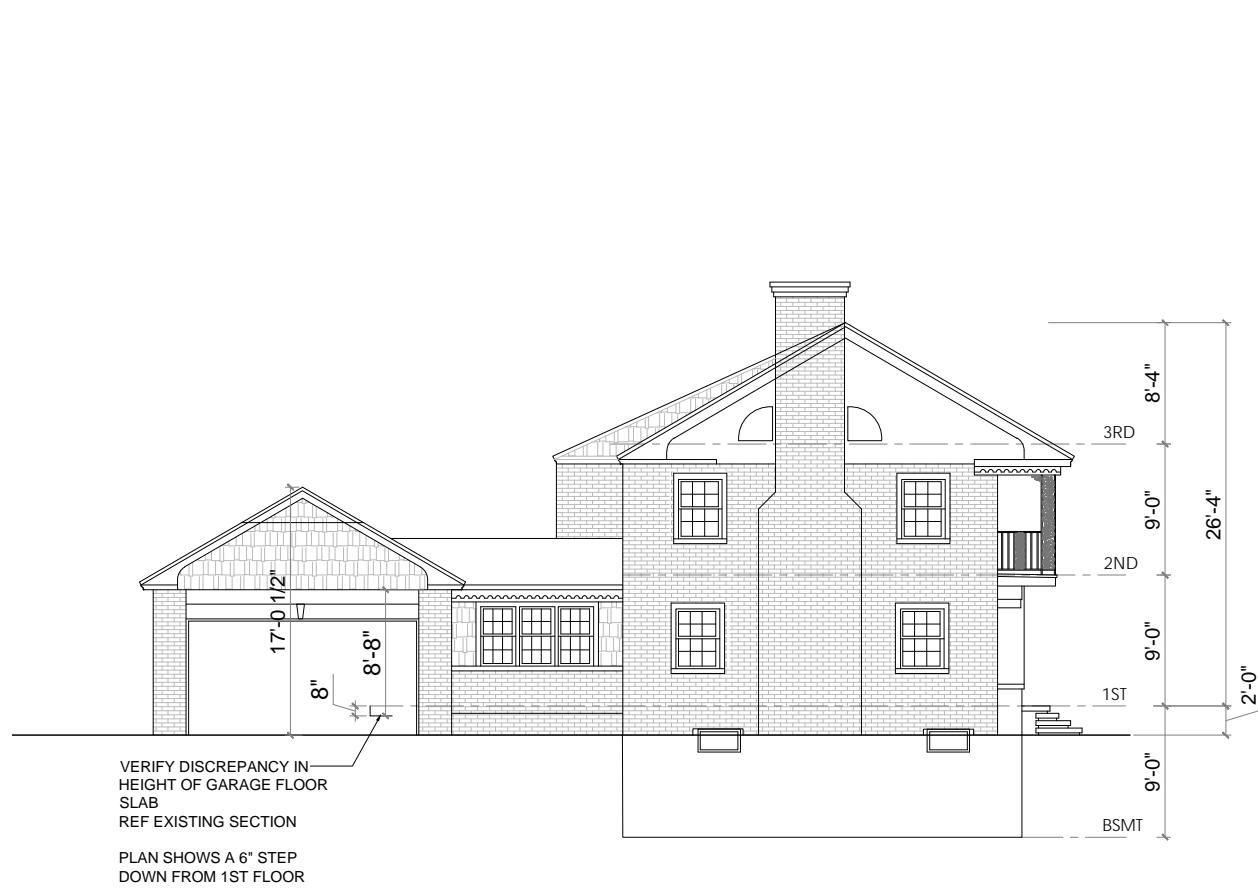

EXISTING NORTH ELEVATION

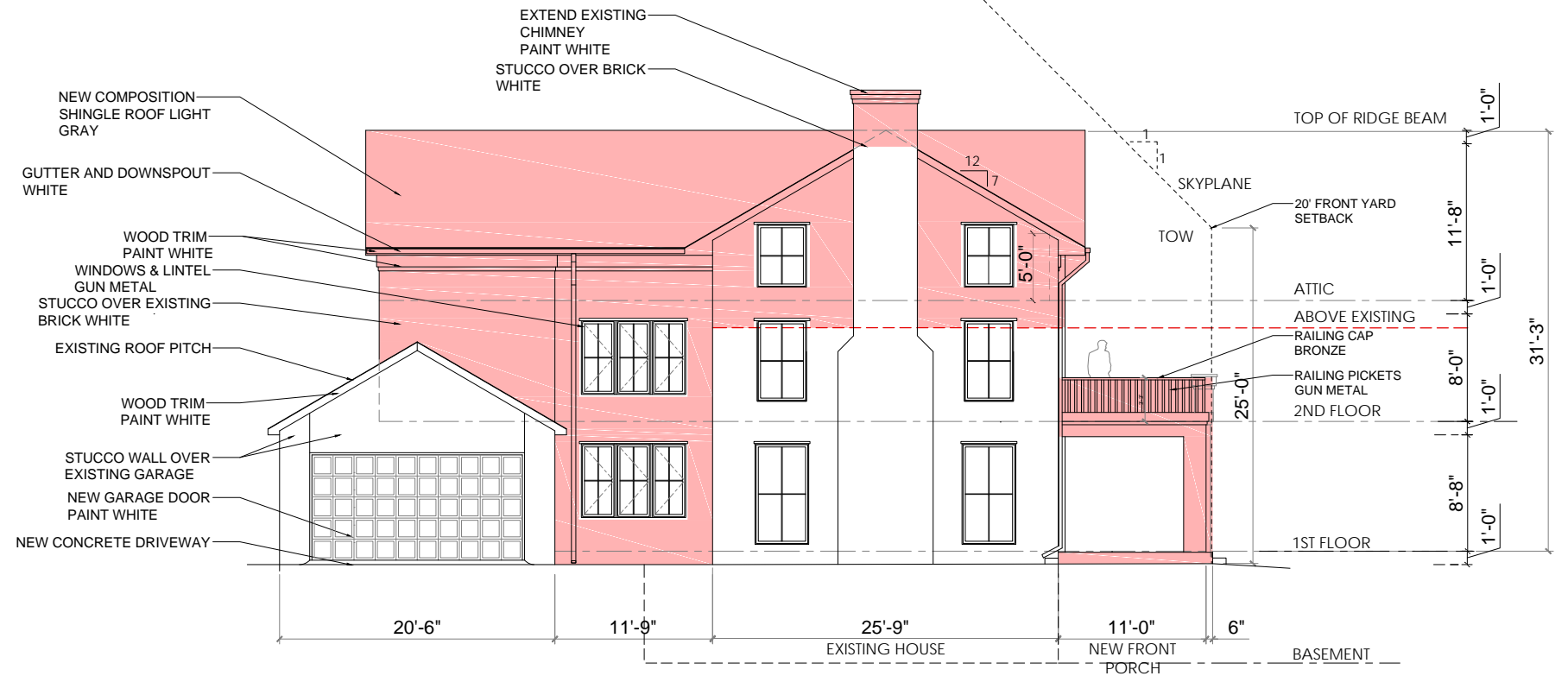

PROPOSED NORTH ELEVATION

PROPOSED EXTENT OF WORK
 NEW ADDITION/ EXTENSION

FORGIONE RESIDENCE

108 SHORE ROAD

DOUGLASTON, NY 11363

DADRAS ARCHITECTS

234-21 41ST AVENUE
 DOUGLASTON, NY 11363
 212 239-8293

NYC-LANDMARKS PRESERVATION COMMISSION

SUBMISSION DATE:08/31/22



PROPOSED NORTH MODEL

FORGIONE RESIDENCE

108 SHORE ROAD

DOUGLASTON, NY 11363

DADRAS ARCHITECTS

234-21 41ST AVENUE

DOUGLASTON, NY 11363

212 239-8293

NYC-LANDMARKS PRESERVATION COMMISSION

SUBMISSION DATE:08/31/22

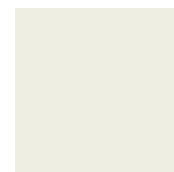

PAIN
 BENJAMIN MOORE
 Moonlight White



ROOF
 Timberline HD Asphalt Shingle
 Fox Hollow Gray



WALL FINISH
 STUCCO Smooth finish



LANDSCAPING
 Evergreens

EXISTING NEIGHBORHOOD PHOTOS

NO TRIM AROUND WINDOWS
STUCCO FINISH
METAL RAILINGS

REFERENCE
 106 Manor Road,
 Douglaston, NY

EXTENT OF WORK NORTH ELEVATION

FORGIONE RESIDENCE

108 SHORE ROAD

DOUGLASTON, NY 11363

DADRAS ARCHITECTS

234-21 41ST AVENUE
 DOUGLASTON, NY 11363
 212 239-8293

NYC-LANDMARKS PRESERVATION COMMISSION

SUBMISSION DATE:08/31/22



EXISTING EAST ELEVATION

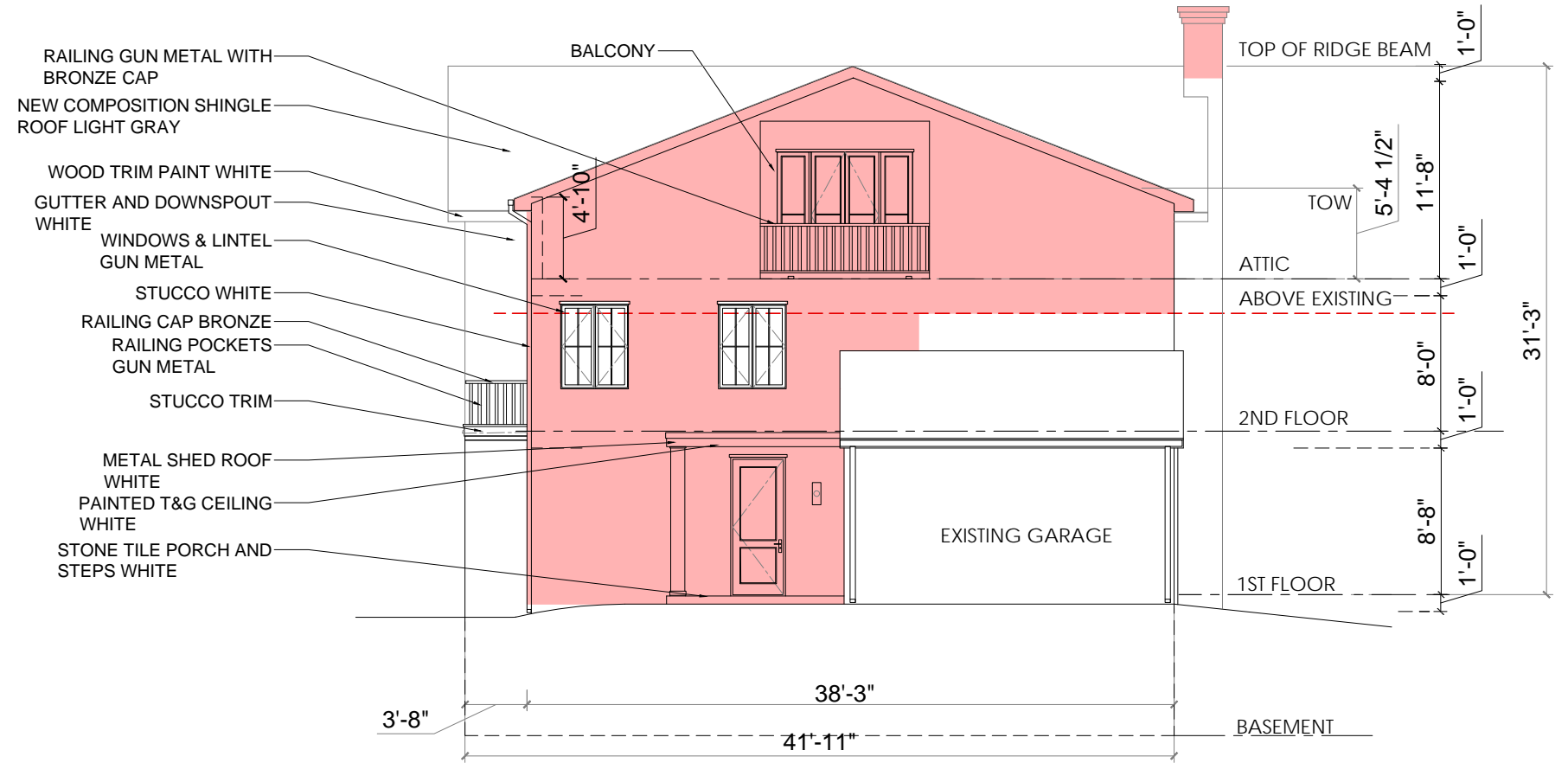

PROPOSED EAST ELEVATION

PROPOSED EXTENT OF WORK
 NEW ADDITION/ EXTENSION

FORGIONE RESIDENCE

108 SHORE ROAD

DOUGLASTON, NY 11363

DADRAS ARCHITECTS

234-21 41ST AVENUE
 DOUGLASTON, NY 11363
 212 239-8293

NYC-LANDMARKS PRESERVATION COMMISSION

SUBMISSION DATE:08/31/22



PROPOSED EAST MODEL

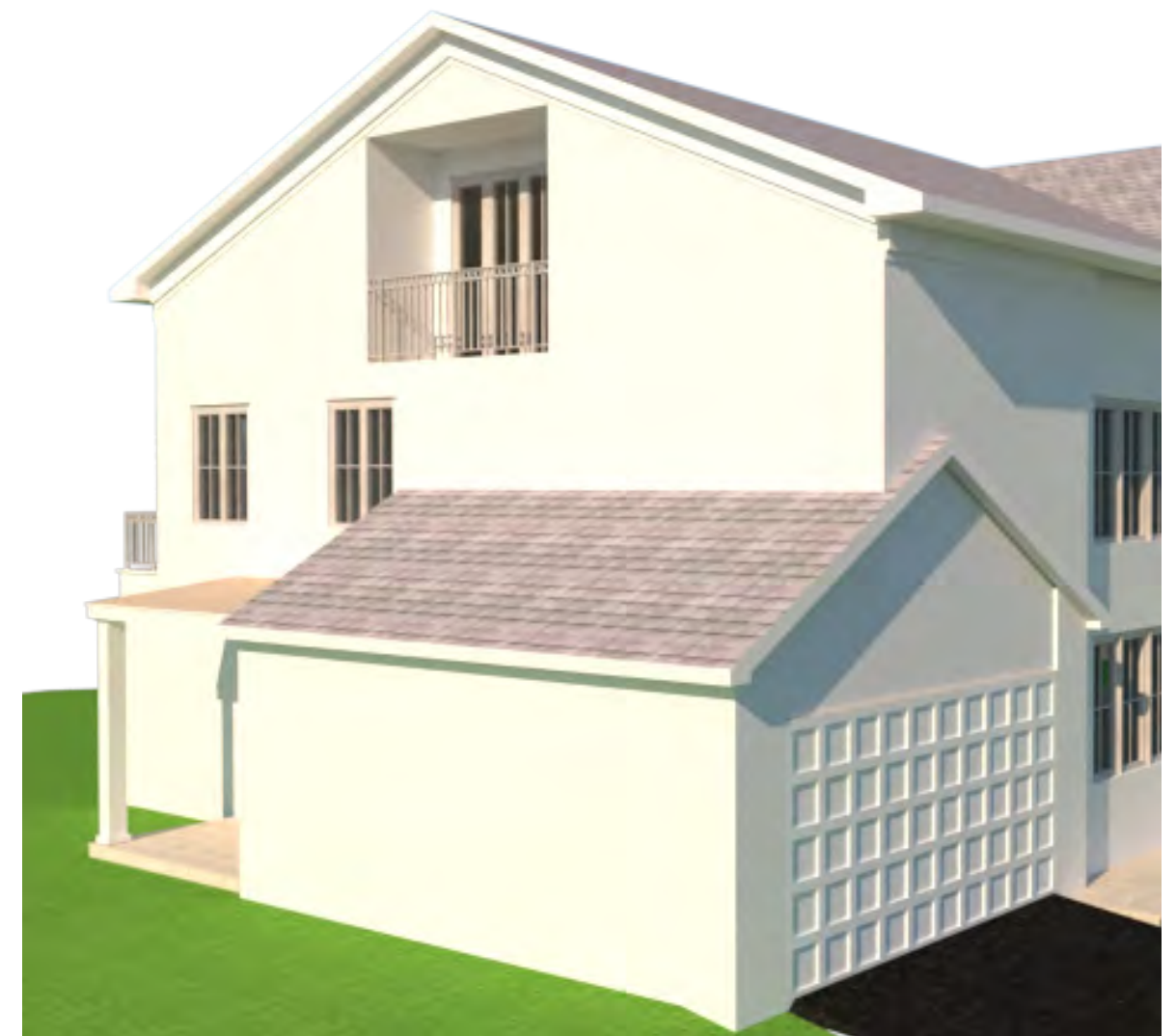

FORGIONE RESIDENCE

108 SHORE ROAD

DOUGLASTON, NY 11363

DADRAS ARCHITECTS

234-21 41ST AVENUE
DOUGLASTON, NY 11363
212 239-8293

NYC-LANDMARKS PRESERVATION COMMISSION

SUBMISSION DATE:08/31/22

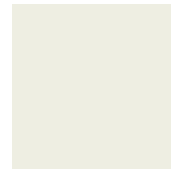

PAIN
 BENJAMIN MOORE
 Moonlight White



ROOF
 Timberline HD Asphalt Shingle
 Fox Hollow Gray



WALL FINISH
 STUCCO Smooth finish



LANDSCAPING
 Evergreens

EXISTING NEIGHBORHOOD PHOTOS

NO TRIM AROUND WINDOWS
STUCCO FINISH

REFERENCE
 DOUGLAS MANOR HOUSES,
 Douglaston, NY

EXTENT OF WORK EAST ELEVATION

FORGIONE RESIDENCE

108 SHORE ROAD

DOUGLASTON, NY 11363

DADRAS ARCHITECTS

234-21 41ST AVENUE
 DOUGLASTON, NY 11363
 212 239-8293

NYC-LANDMARKS PRESERVATION COMMISSION

SUBMISSION DATE:08/31/22

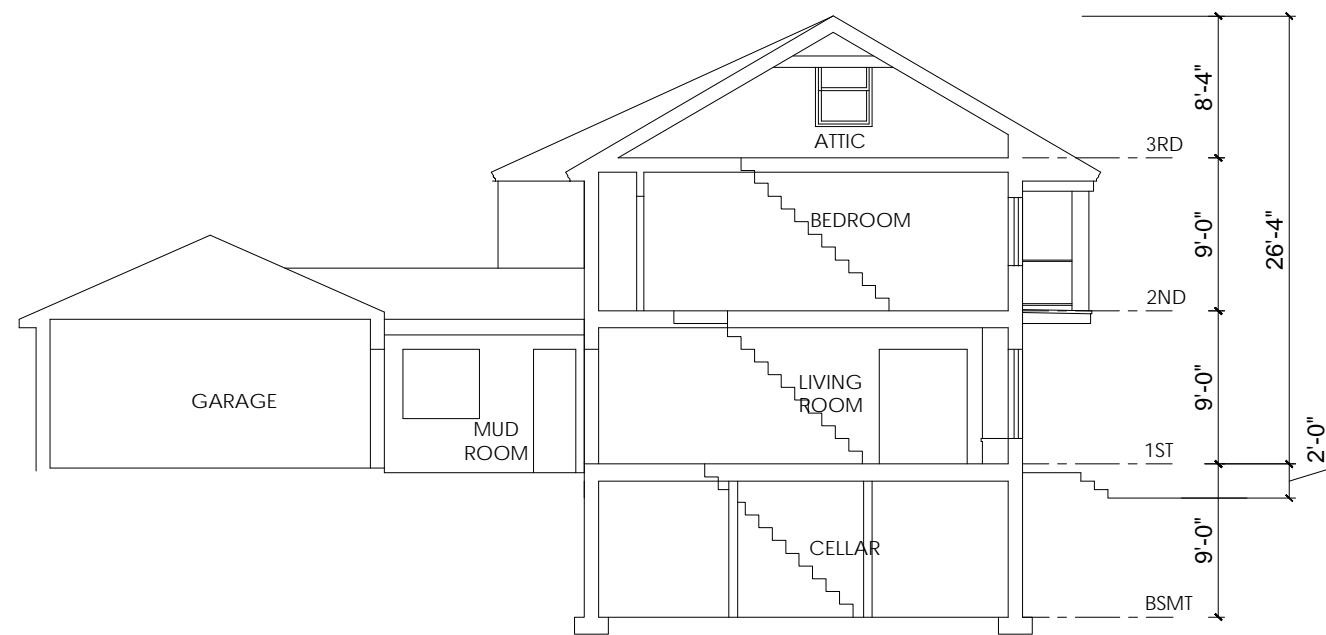

EXISTING SECTION

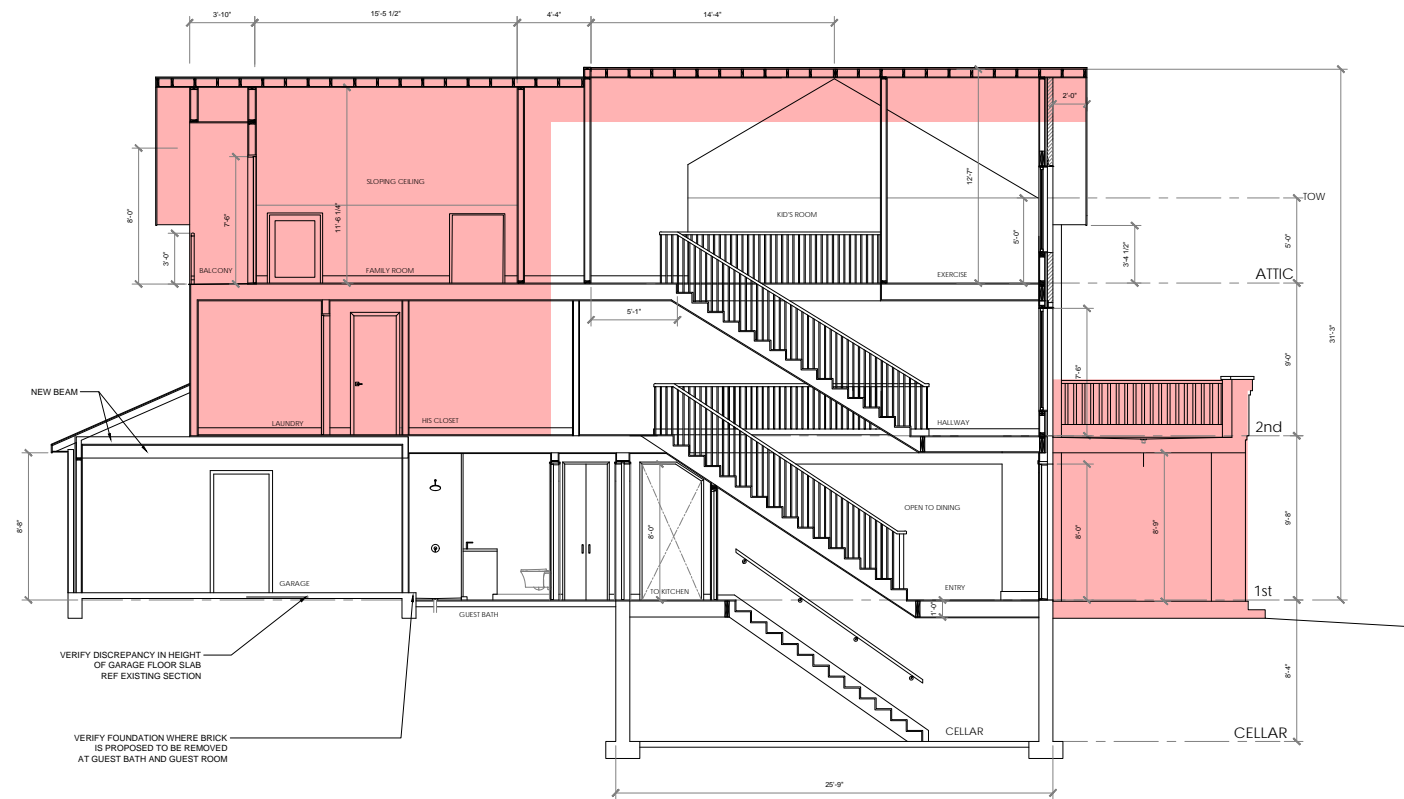

PROPOSED SECTION

FORGIONE RESIDENCE

108 SHORE ROAD

DOUGLASTON, NY 11363

DADRAS ARCHITECTS

234-21 41ST AVENUE

DOUGLASTON, NY 11363

212 239-8293

NYC-LANDMARKS PRESERVATION COMMISSION

SUBMISSION DATE:08/31/22



STREET FRONT ELEVATION, SHORE RD STREET

1. NEW STONE TILE CLAD CONCRETE PORCH AND STEPS
2. NEW EXTENDED BALCONY OVER PORCH WITH STONE TILE FLOOR WITH DRAINS
3. PAINTED STEEL GUARDRAIL
4. DORMER ROOF ABOVE EXISTING ATTIC
5. STUCCO FINISH ON COLUMNS AND EXISTING BRICK WALL
6. NEW EXTERIOS DOORS AND WINDOWS
7. RAILING CAP BRONZE
- 8.. NEW COMPOSITION SHINGLE ROOF LIGHT GRAY

SIDE ELEVATIONS

9. NEW EXTERIOS DOORS AND WINDOWS
10. NEW BALCONY AND RAILINGS
11. STUCCO FINISH
12. NEW RAILINGS FOR OPENING AROUND STAIRCASE GOING DOWN TO CELLAR
13. EXTENDED CHIMNEY
14. NEW GARAGE DOOR PAINT WHITE
15. NEW CONCRETE DRIVEWAY

REAR ELEVATION

16. MECHANICAL PIT BEYOND STUCCO WALL
17. METAL SHED ROOF WHITE
18. BALCONY
19. STUCCO FINISH
20. NEW PORCH ENTRANCE WITH METAL SHED ROOF WHITE, STONE TILE FLOOR AND STEPS.

PROPOSED MODIFICATIONS

FORGIONE RESIDENCE

108 SHORE ROAD

DOUGLASTON, NY 11363

DADRAS ARCHITECTS

234-21 41ST AVENUE
DOUGLASTON, NY 11363
212 239-8293

NYC-LANDMARKS PRESERVATION COMMISSION

SUBMISSION DATE:08/31/22



EXISTING REFERENCE: 25-04 WEST DR



EXISTING REFERENCE: 141 PARK LN

EXISTING REFERENCE: DOUGLAS MANOR HOUSES

EXTERIOR WALLS AND COLOR

PAINT:
BENJAMIN MOORE
Moonlight White (2143-60)

WALL FINISH:
STUCCO

TYPE:
SMOOTH

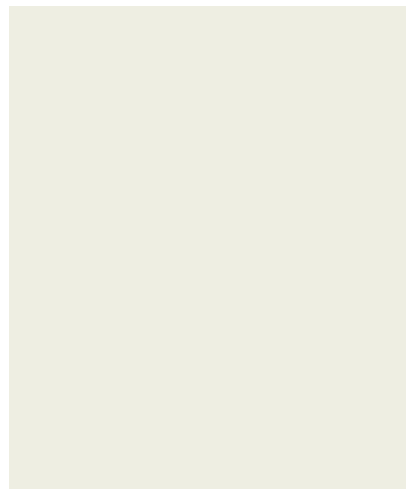

PROPOSED MATERIALS AND REFERENCES

COLUMNS

MOULDING DETAIL ABOVE ENTRANCE-
WAY AND UNDER BALCONIES.



LANDSCAPE

GRADE THE LAND TO BE FLUSH WITH
FRONT PORCH, SLOPING DOWN 4 OR 5
FEET BEFORE THE PROPERTY LINE.

ADDING EVERGREENS ALONG THE
WEST AND NORTH ELEVATIONS FACING
PROPERTY LINES.



FORGIONE RESIDENCE

108 SHORE ROAD

DOUGLASTON, NY 11363

DADRAS ARCHITECTS

234-21 41ST AVENUE
DOUGLASTON, NY 11363
212 239-8293

NYC-LANDMARKS PRESERVATION COMMISSION

SUBMISSION DATE:08/31/22



ROOFING

MAIN ROOF
 BRAND: GAF // TIMBERLINE HD
 ASPHALT SHINGLE
 COLOR: FOX HOLLOW GRAY



REAR PORCH AND BALCONY
 BACK DOOR: STANDING SEAM
 METAL SHED ROOF
 COLOR: BEIGE



EXISTING REFERENCE:
 104 KNOLLWOOD, DOUGLASTON, NY

FLAT ROOFS



EXISTING REFERENCE:
 27-03 SHORE RD, DOUGLASTON, NY

PROPOSED MATERIALS AND REFERENCES



RAILINGS

IRON RAILINGS WITH CIRCLE
 DETAIL
 COLOR: PAINTED TO MATCH
 WINDOW GRILLE
 (SEE WINDOW/DOOR DETAIL)

FLOORING

DECKS, BALCONIES, STEPS AND
 WALKWAYS.
 TRAVERTINE LOOK PORCELAIN
 BRAND: TILE SHOP CHESTER
 VERSAILLES PORCELAIN TILES
 COLOR: CREAM



FORGIONE RESIDENCE

108 SHORE ROAD

DOUGLASTON, NY 11363

DADRAS ARCHITECTS

234-21 41ST AVENUE
 DOUGLASTON, NY 11363
 212 239-8293

NYC-LANDMARKS PRESERVATION COMMISSION

SUBMISSION DATE:08/31/22

ELEVATION

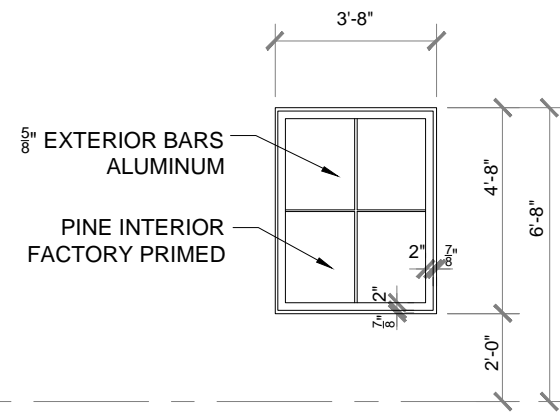

13

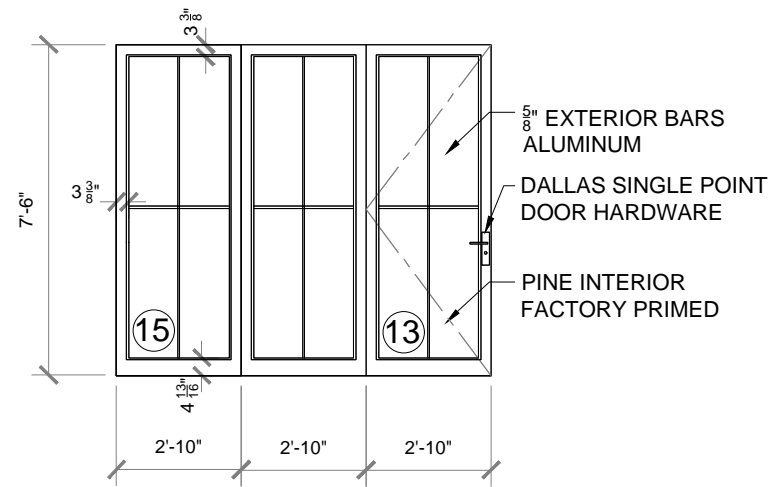

13 15

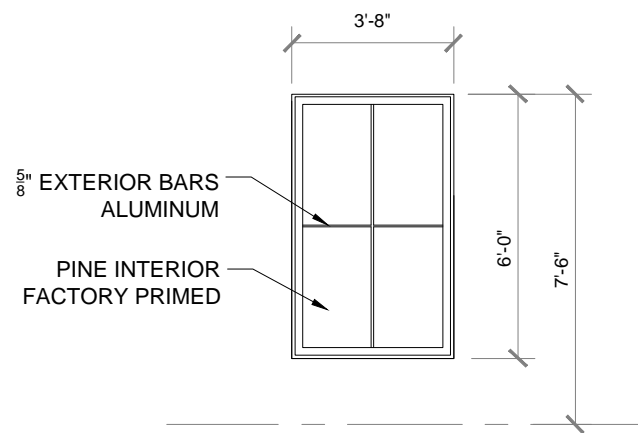

17



DOOR AND WINDOW SCHEDULE
WEST ELEVATION

FORGIONE RESIDENCE

108 SHORE ROAD

DOUGLASTON, NY 11363

DADRAS ARCHITECTS

234-21 41ST AVENUE

DOUGLASTON, NY 11363

212 239-8293

NYC-LANDMARKS PRESERVATION COMMISSION

SUBMISSION DATE:08/31/22

ELEVATION

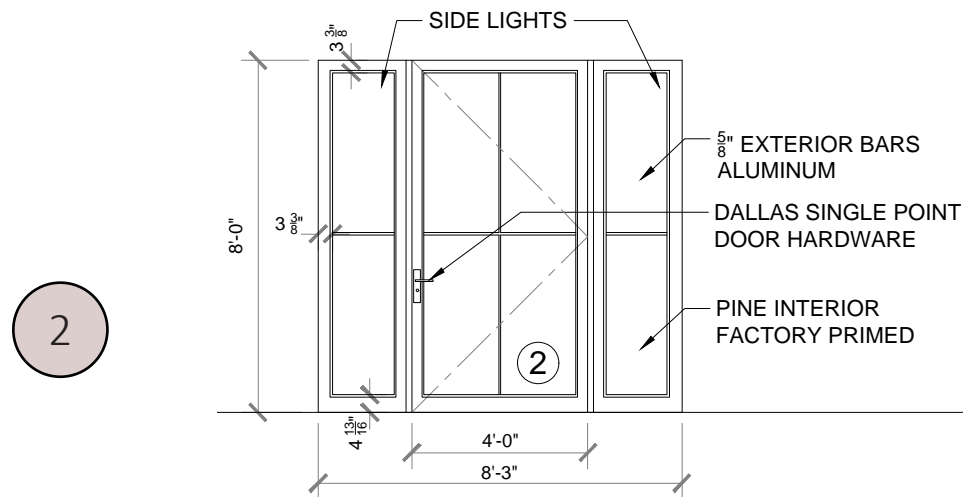
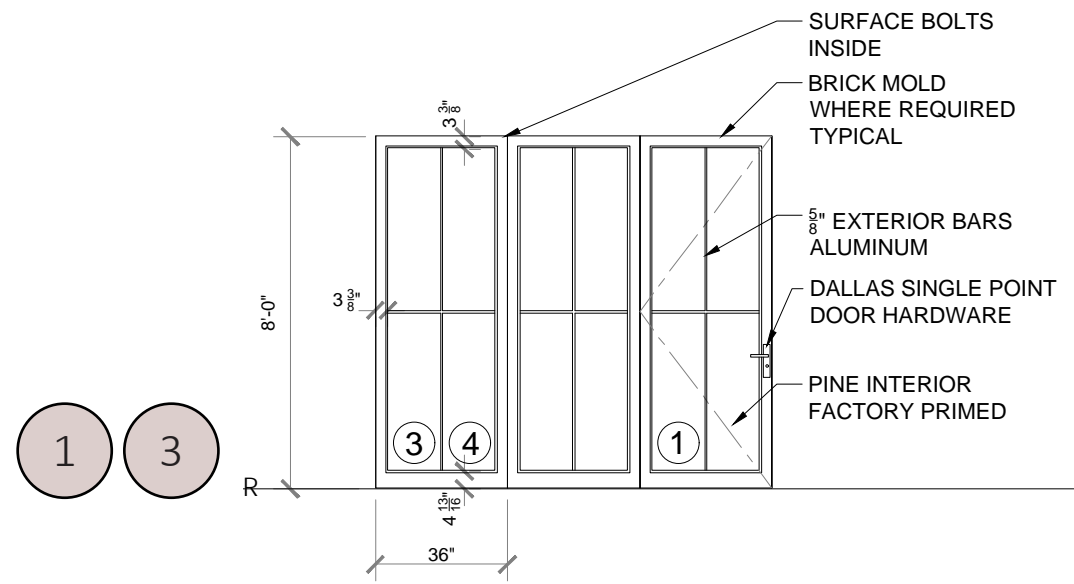

DOOR AND WINDOW SCHEDULE
WEST ELEVATION

FORGIONE RESIDENCE

108 SHORE ROAD

DOUGLASTON, NY 11363

DADRAS ARCHITECTS

234-21 41ST AVENUE

DOUGLASTON, NY 11363

212 239-8293

NYC-LANDMARKS PRESERVATION COMMISSION

SUBMISSION DATE:08/31/22

ELEVATION

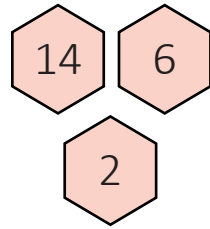
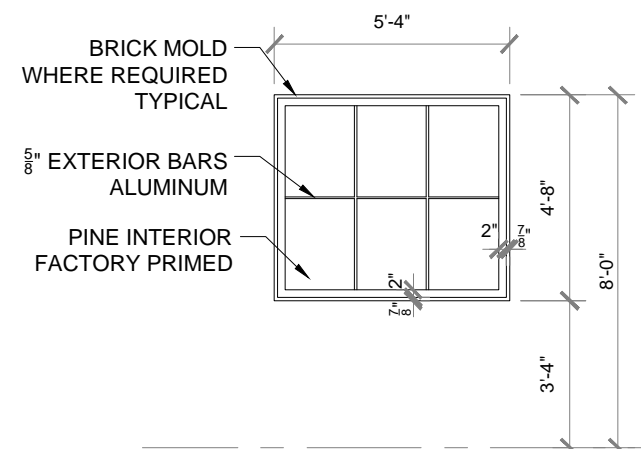
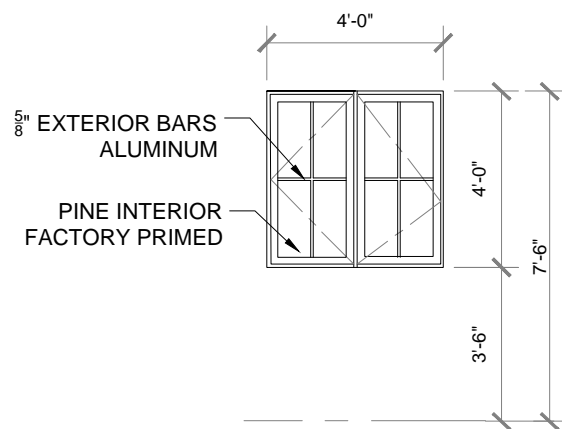
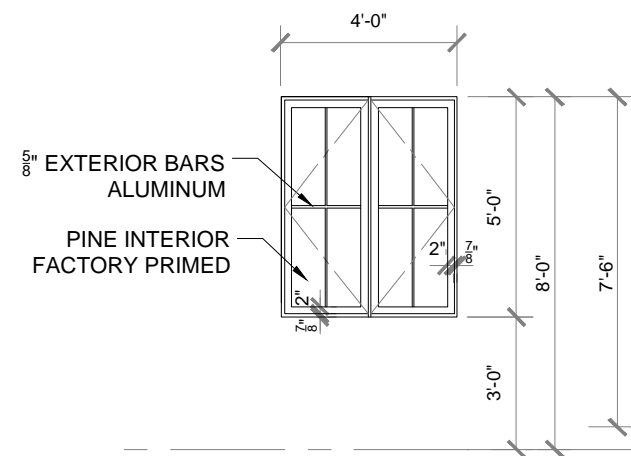

DOOR AND WINDOW SCHEDULE
SOUTH ELEVATION

FORGIONE RESIDENCE

108 SHORE ROAD

DOUGLASTON, NY 11363

DADRAS ARCHITECTS

234-21 41ST AVENUE
DOUGLASTON, NY 11363
212 239-8293

NYC-LANDMARKS PRESERVATION COMMISSION

SUBMISSION DATE:08/31/22

ELEVATION

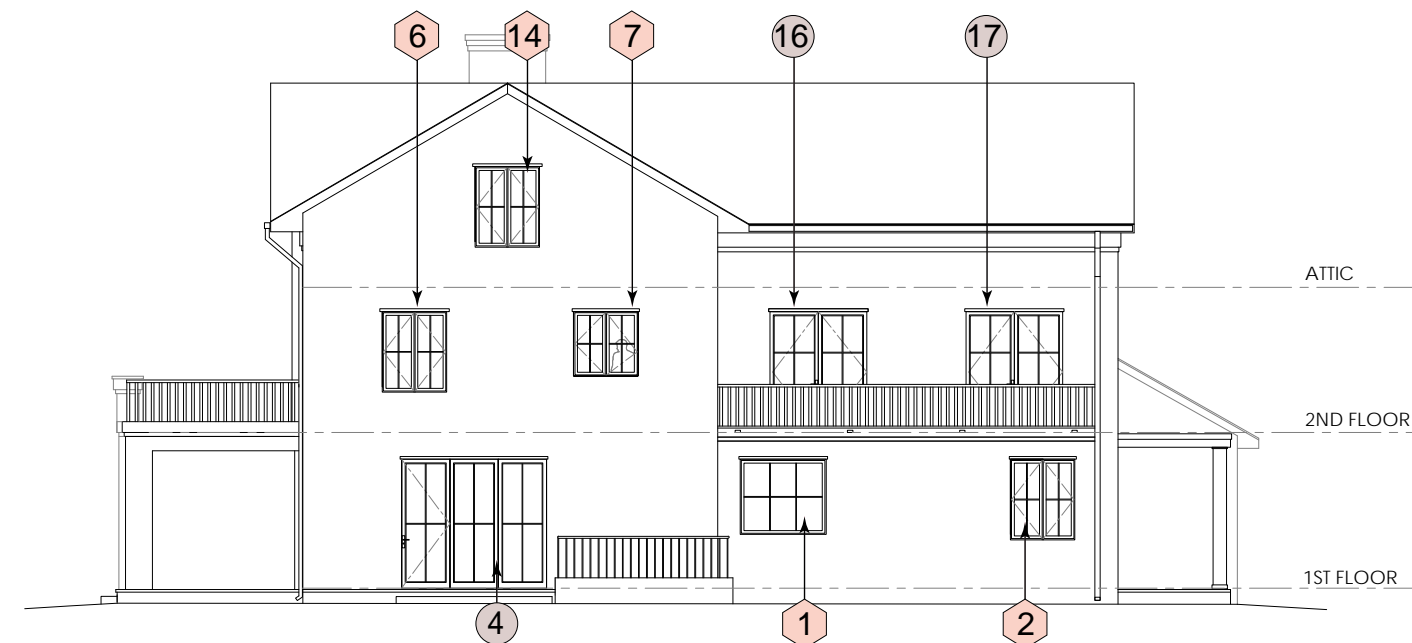
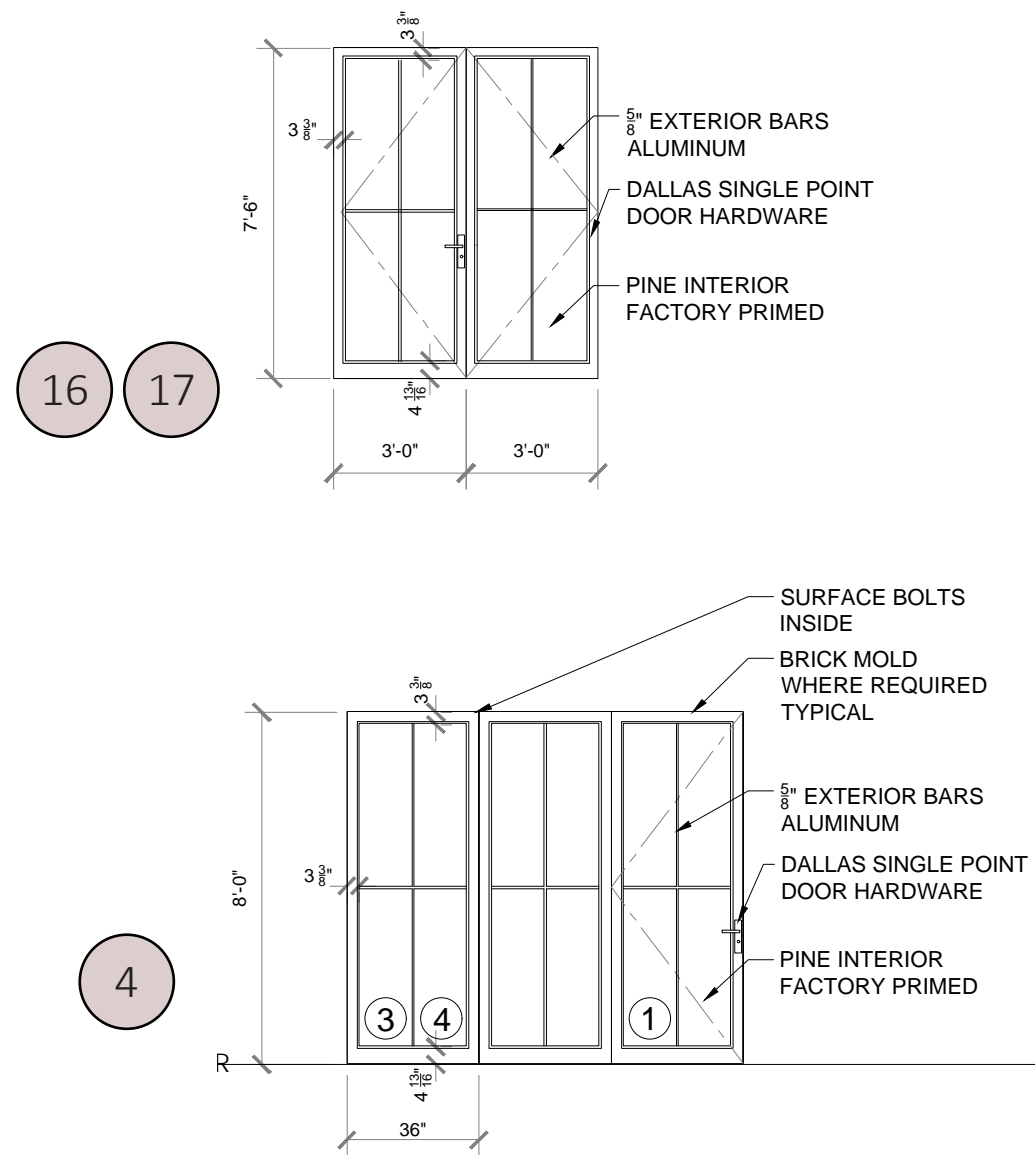

DOOR AND WINDOW SCHEDULE
SOUTH ELEVATION

FORGIONE RESIDENCE

108 SHORE ROAD

DOUGLSTON, NY 11363

DADRAS ARCHITECTS

234-21 41ST AVENUE
DOUGLSTON, NY 11363
212 239-8293

NYC-LANDMARKS PRESERVATION COMMISSION

SUBMISSION DATE:08/31/22

ELEVATION

15 16

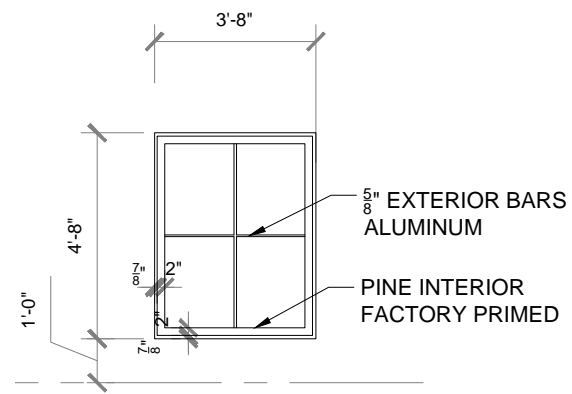

10 3

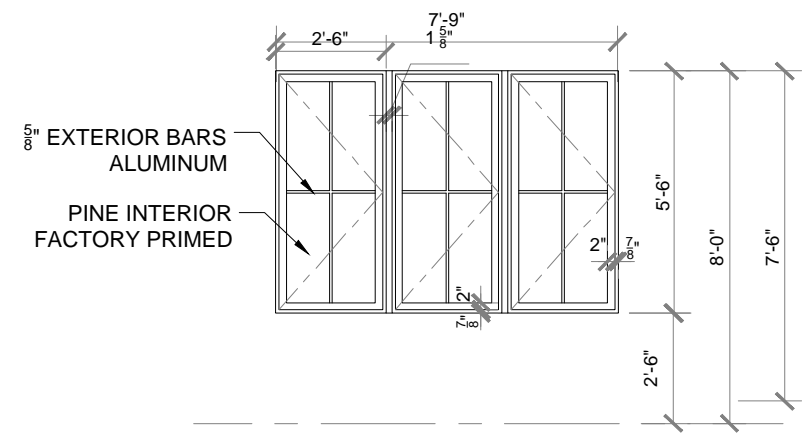

11 12

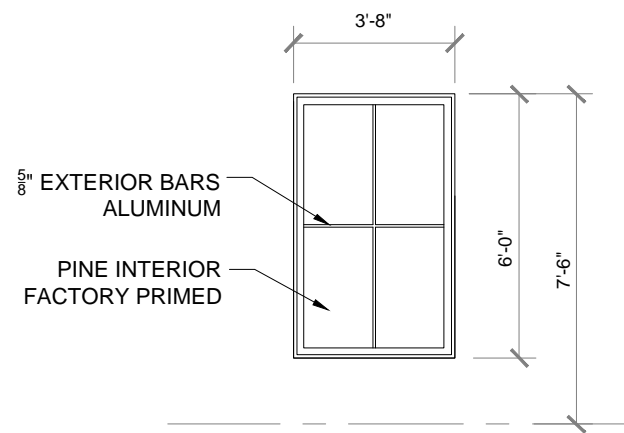

4 5

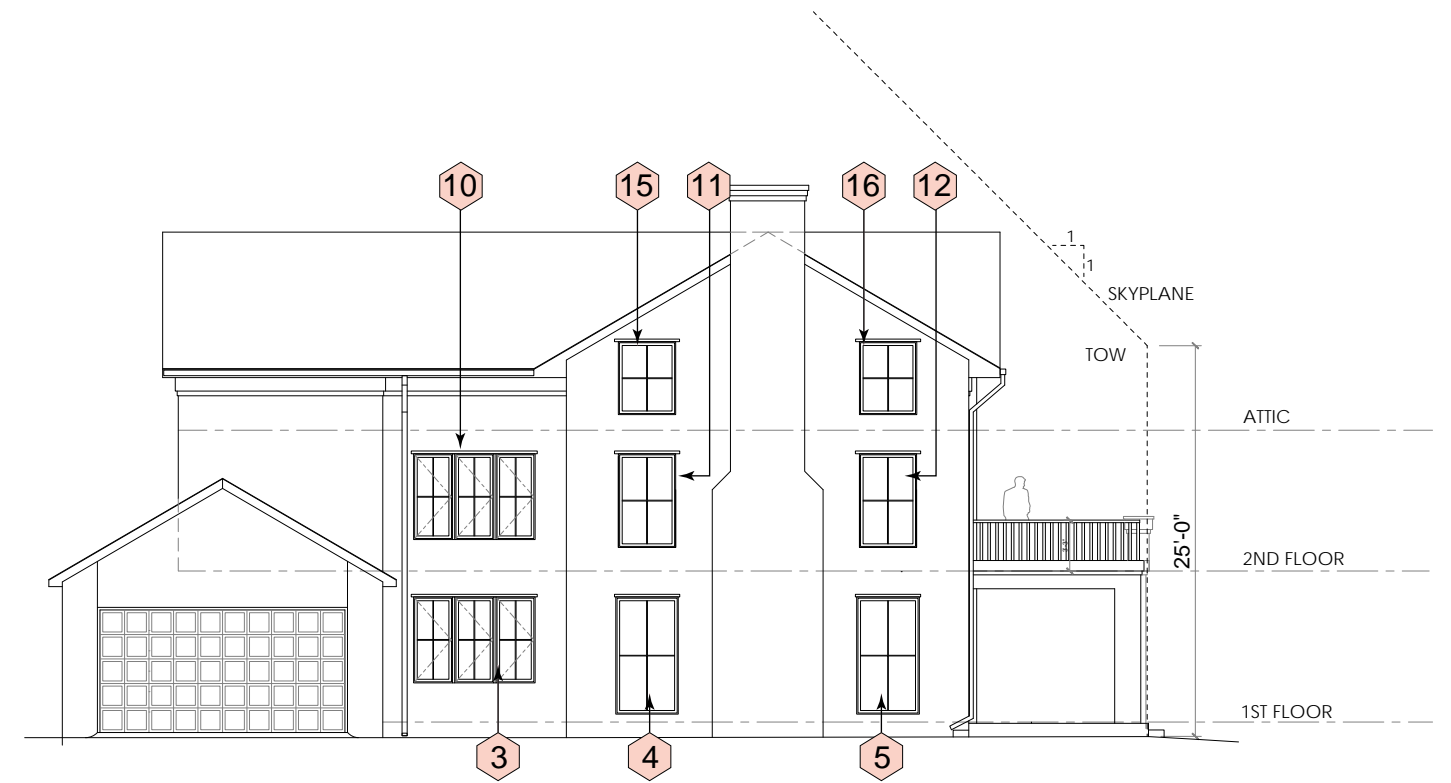
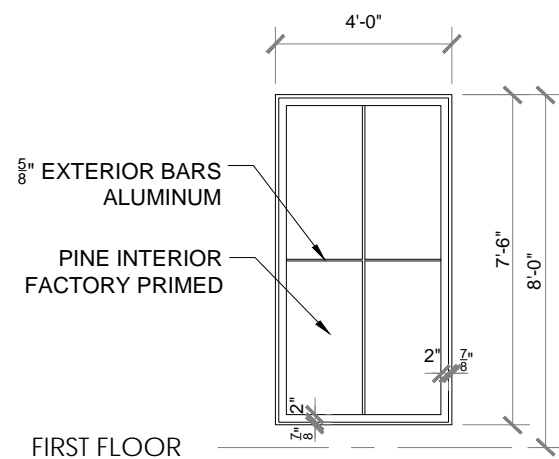

DOOR AND WINDOW SCHEDULE
NORTH ELEVATION

FORGIONE RESIDENCE

108 SHORE ROAD

DOUGLASTON, NY 11363

DADRAS ARCHITECTS

234-21 41ST AVENUE
DOUGLASTON, NY 11363
212 239-8293

NYC-LANDMARKS PRESERVATION COMMISSION

SUBMISSION DATE:08/31/22

ELEVATION

30

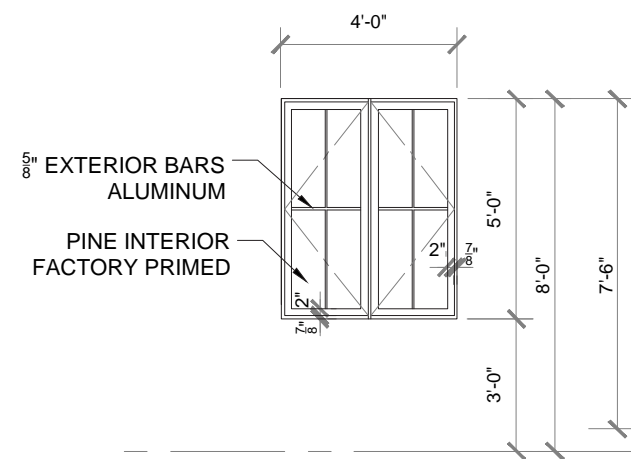
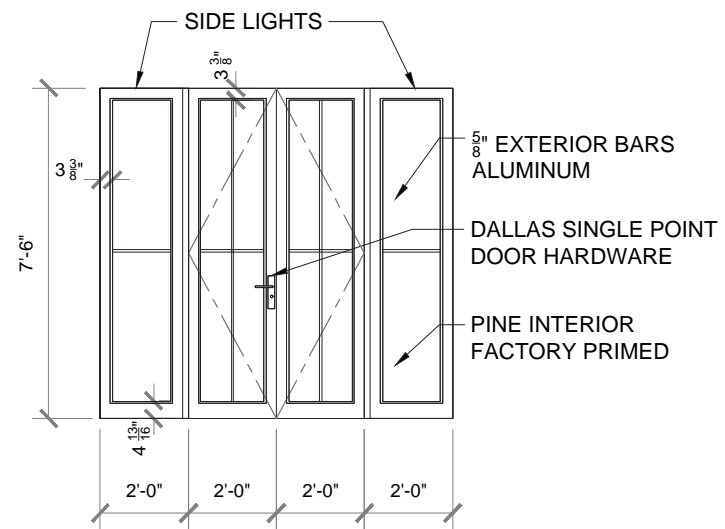

8 9

5

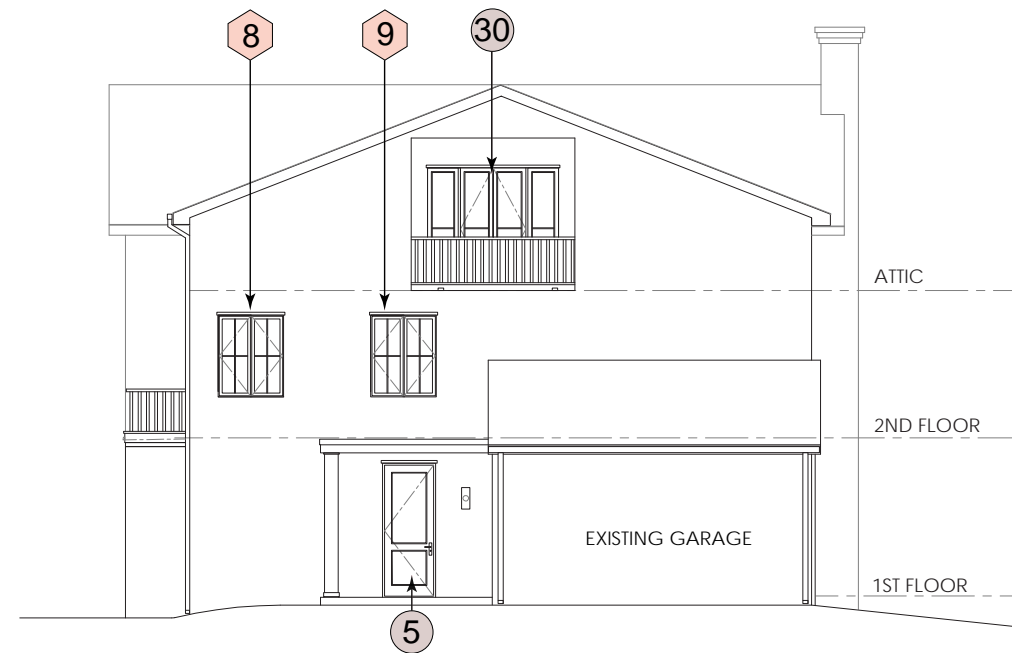
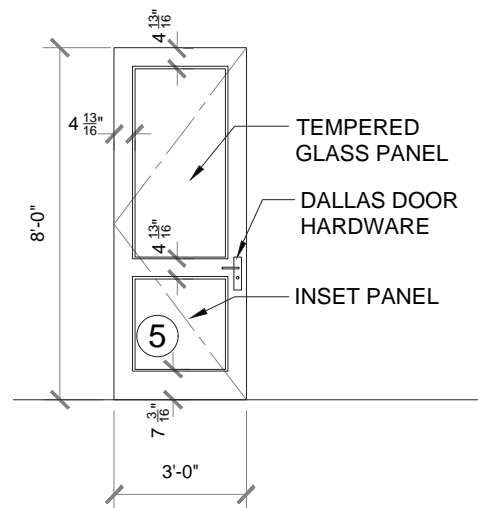

DOOR AND WINDOW SCHEDULE
EAST ELEVATION

FORGIONE RESIDENCE

108 SHORE ROAD

DOUGLASTON, NY 11363

DADRAS ARCHITECTS

234-21 41ST AVENUE
DOUGLASTON, NY 11363
212 239-8293

NYC-LANDMARKS PRESERVATION COMMISSION

SUBMISSION DATE:08/31/22



EXISTING REFERENCE: 25-04 WEST DR



EXISTING REFERENCE: 25-04 WEST DR



EXISTING REFERENCE: 7 HOLLYWOOD AVENUE

EXISTING REFERENCES:
DOUGLAS MANOR HOUSES

WINDOWS/ DOORS



EXISTING REFERENCE: 706 SHORE RD



EXISTING REFERENCE: 706 SHORE RD

EXTERIOR TRIM : NO EXTERIOR/WINDOW TRIM
WINDOW SILL : SAME STONE AS PORCH/WALKWAY/
STAIRS.

SIMULATED DIVIDED LIGHT
WOOD CORE, ALUMINUM CLAD
POWDER FINISH ON ALUMINUM: LINEN



PROPOSED MATERIALS AND REFERENCES

FORGIONE RESIDENCE

108 SHORE ROAD

DOUGLASTON, NY 11363

DADRAS ARCHITECTS

234-21 41ST AVENUE
DOUGLASTON, NY 11363
212 239-8293

NYC-LANDMARKS PRESERVATION COMMISSION

SUBMISSION DATE:08/31/22



**EXISTING SHORE RD PHOTO
WEST ELEVATION**



**PROPOSED SHORE RD VIEW
WEST ELEVATION**

FORGIONE RESIDENCE

108 SHORE ROAD

DOUGLASTON, NY 11363

DADRAS ARCHITECTS

234-21 41ST AVENUE
DOUGLASTON, NY 11363
212 239-8293

NYC-LANDMARKS PRESERVATION COMMISSION

SUBMISSION DATE:08/31/22



**EXISTING HOLLYWOOD AVE PHOTO
SOUTH-WEST ELEVATION**



**PROPOSED HOLLYWOOD AVE VIEW
SOUTH-WEST ELEVATION**

FORGIONE RESIDENCE

108 SHORE ROAD

DOUGLASTON, NY 11363

DADRAS ARCHITECTS

234-21 41ST AVENUE
DOUGLASTON, NY 11363
212 239-8293

NYC-LANDMARKS PRESERVATION COMMISSION

SUBMISSION DATE:08/31/22



EXISTING NORTH-WEST PHOTO



PROPOSED NORTH-WEST VIEW

FORGIONE RESIDENCE

108 SHORE ROAD

DOUGLASTON, NY 11363

DADRAS ARCHITECTS

234-21 41ST AVENUE
DOUGLASTON, NY 11363
212 239-8293

NYC-LANDMARKS PRESERVATION COMMISSION

SUBMISSION DATE:08/31/22



**EXISTING HOLLYWOOD AV PHOTO
NORTH ELEVATION**



**PROPOSED HOLLYWOOD AV VIEW
NORTH ELEVATION**

FORGIONE RESIDENCE

108 SHORE ROAD

DOUGLASTON, NY 11363

DADRAS ARCHITECTS

234-21 41ST AVENUE
DOUGLASTON, NY 11363
212 239-8293

NYC-LANDMARKS PRESERVATION COMMISSION

SUBMISSION DATE:08/31/22



FORGIONE RESIDENCE

108 SHORE ROAD

DOUGLASTON, NY 11363

DADRAS ARCHITECTS

234-21 41ST AVENUE
DOUGLASTON, NY 11363
212 239-8293

NYC-LANDMARKS PRESERVATION COMMISSION

SUBMISSION DATE:08/31/22



FORGIONE RESIDENCE

108 SHORE ROAD

DOUGLASTON, NY 11363

DADRAS ARCHITECTS

234-21 41ST AVENUE

DOUGLASTON, NY 11363

212 239-8293

NYC-LANDMARKS PRESERVATION COMMISSION

SUBMISSION DATE:08/31/22

The current proposal is:

Preservation Department – Item 2, LPC-22-11753

108 Shore Road – Douglaston Historic District
Borough of Queens

To Testify Please Join Zoom

Webinar ID: 846 5008 0041

Passcode: 554001

By Phone: 1 646-558-8656 US (New York)

877-853-5257 (Toll free) US

888 475 4499 (Toll free)

Note: If you want to testify on an item, join the Zoom webinar at the agenda’s “Be Here by” time (about an hour in advance). When the Chair indicates it’s time to testify, “raise your hand” via the Zoom app if you want to speak (*9 on the phone). Those who signed up in advance will be called first.