

The current proposal is:

Preservation Department – Item 9, LPC-22-11104

**65 Jumel Terrace – Morris-Jumel Mansion - Individual and  
Interior Landmark – Jumel Terrace Historic District  
Borough of Manhattan**

To Testify Please Join Zoom

**Webinar ID:** 868 9794 8074

**Passcode:** 501977

By Phone: 1 646-558-8656 US (New York)

877-853-5257 (Toll free) US

888 475 4499 (Toll free)

**Note:** If you want to testify on an item, join the Zoom webinar at the agenda’s “Be Here by” time (about an hour in advance). When the Chair indicates it’s time to testify, “raise your hand” via the Zoom app if you want to speak (\*9 on the phone). Those who signed up in advance will be called first.



## **The Morris-Jumel Mansion Exterior Restoration & ADA Accessibility Upgrade**

### **Project Type:**

HHT Sole Source Design

### **Scope of Work:**

Exterior restoration of mansion

ADA accessibility to first floor & restrooms

### **Consultant Team:**

Page Ayres Cowley Architecture, LLC



**The Morris-Jumel Mansion**

**Exterior Restoration & ADA Accessibility Upgrade**

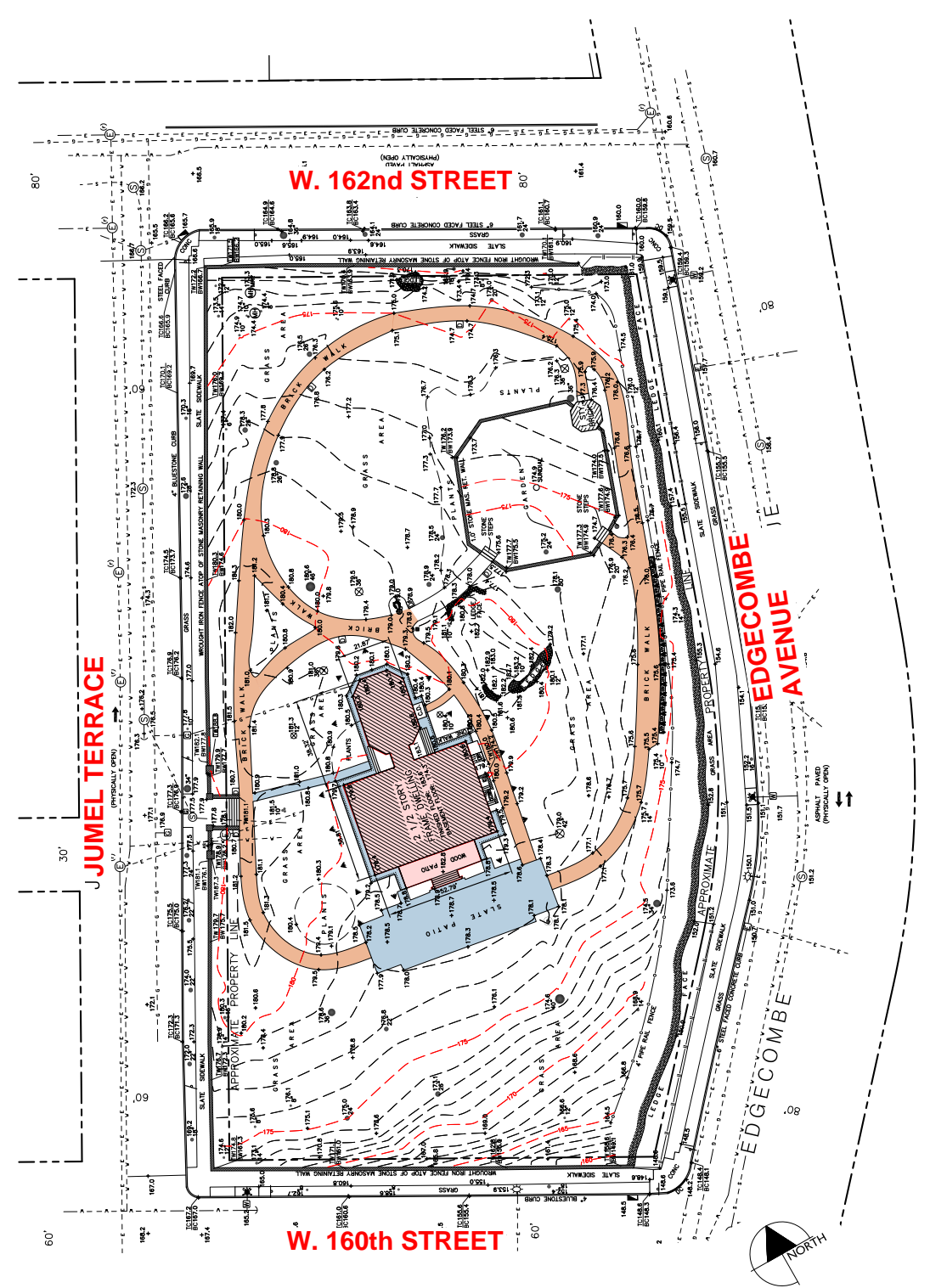

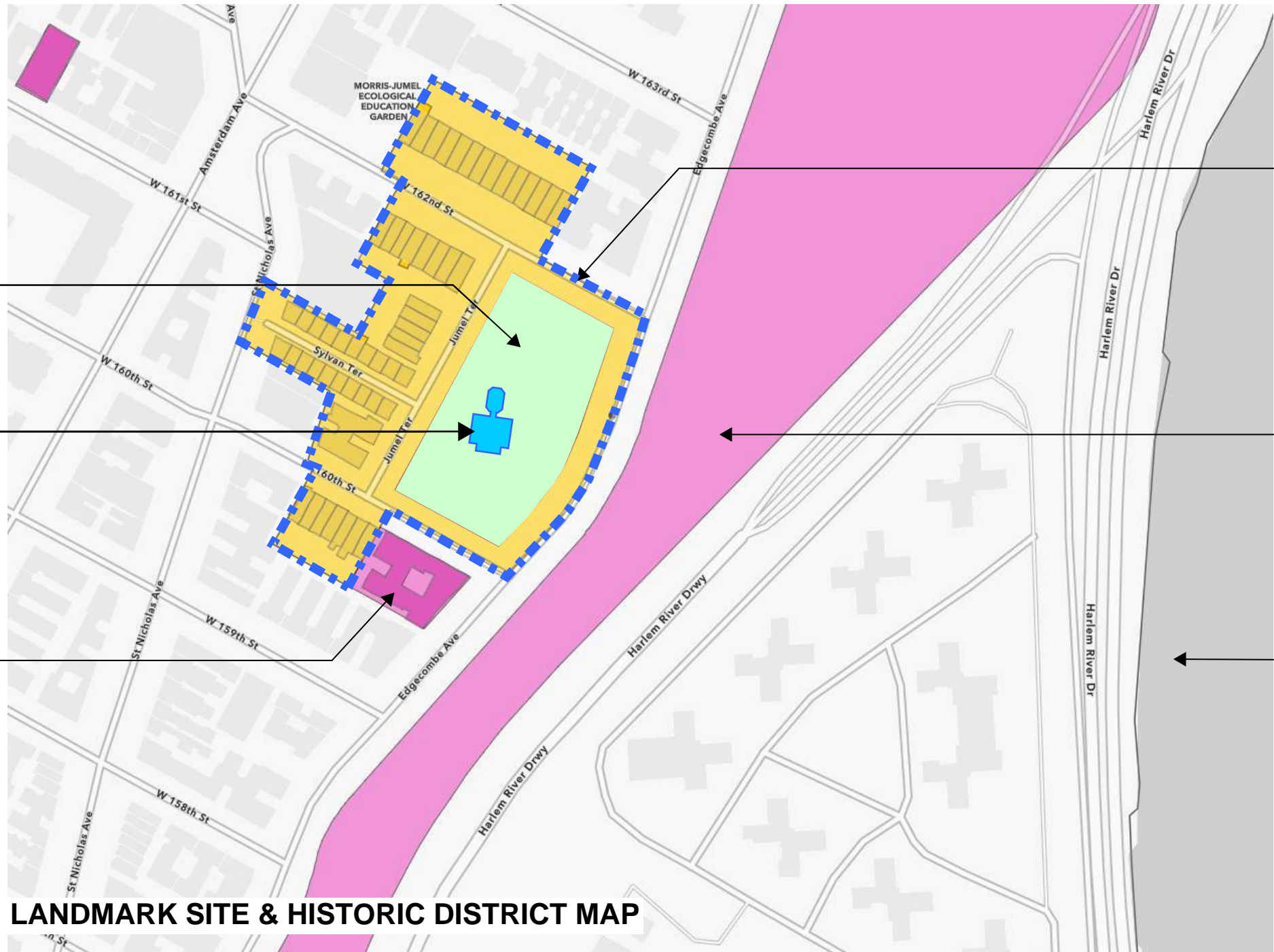

**Roger Morris Park**  
 Landmark Site:  
 Block 2109, Lot 106

**The Morris-Jumel Mansion**  
 Individual Landmark,  
 Constructed: 1765  
 Major Alteration: 1810

**555 Edgecomb Avenue  
 Apartments**  
 Individual Landmark

**Jumel Terrace Historic District**

**Highbridge, Aqueduct &  
 Pedestrian Walk**  
 Individual Landmark

**Harlem River**

**LANDMARK SITE & HISTORIC DISTRICT MAP**





View of the South Elevation & Portico, Colorized Postcard, C. 1904, NYPL Archives

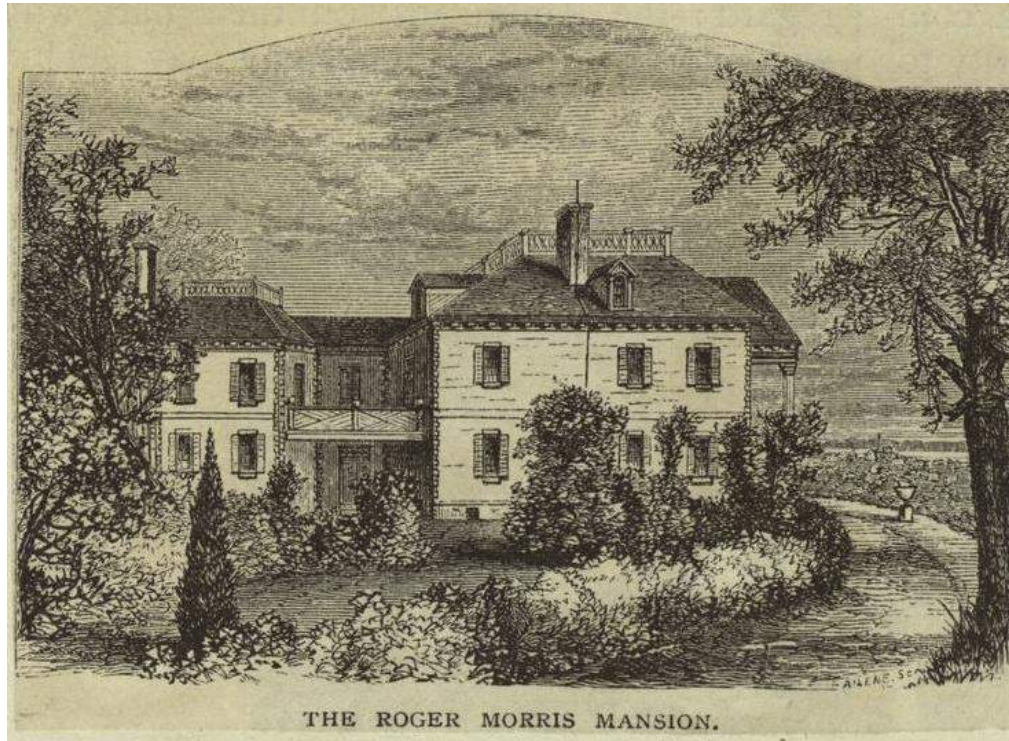

View of the West Elevation, Wood Engraving, C. 1876, NYPL Archives



View from the Southwest, Wood Engraving, C. 1915, NYPL Archives



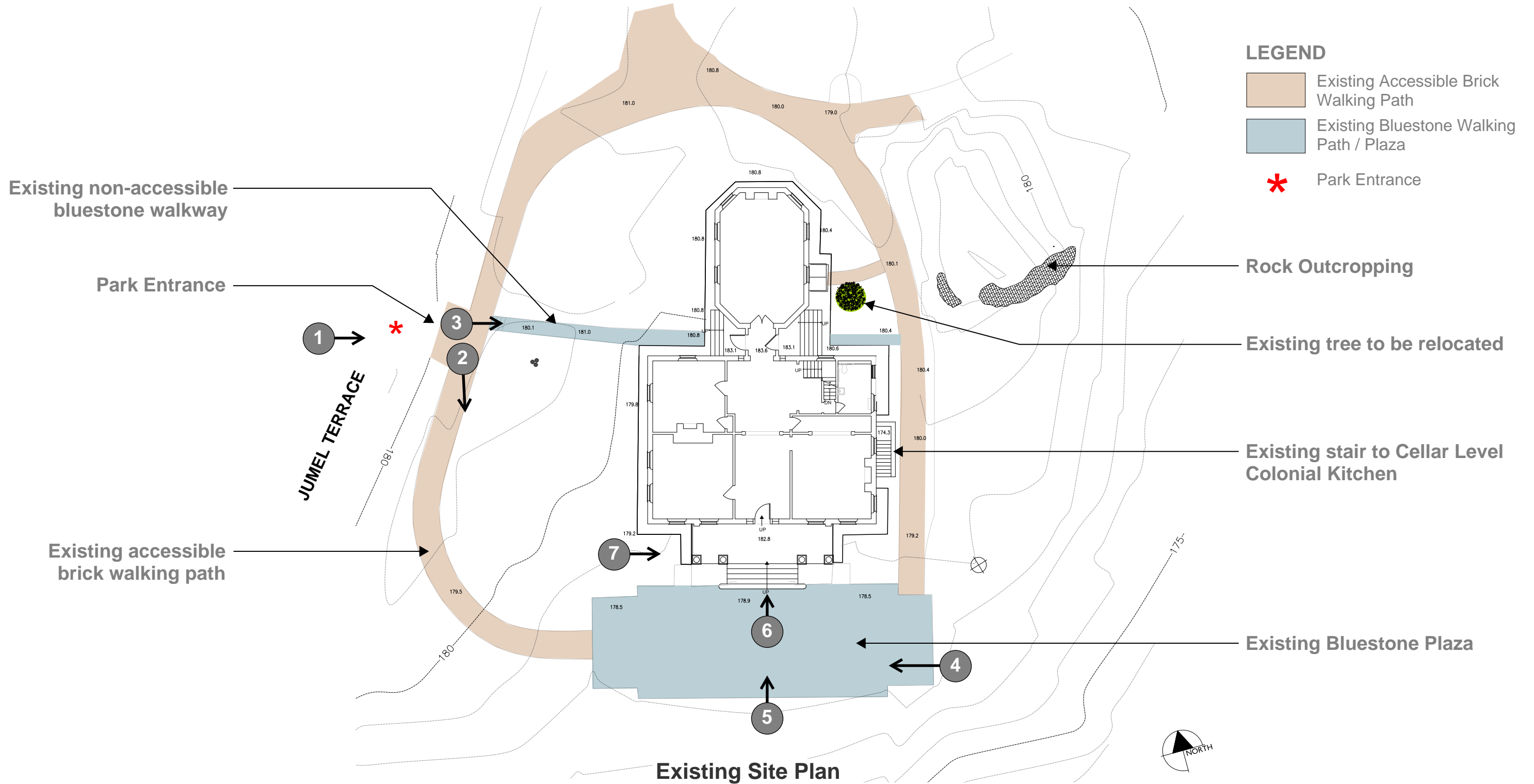



1. View of park entrance from the West (Jumel Terrace)



2. View of accessible walk paths adjacent to park entrance



3. View of non-accessible walking path at West side of mansion



4. View of bluestone plaza, South side of Morris-Jumel Mansion



5. View of South Elevation, Morris-Jumel Mansion

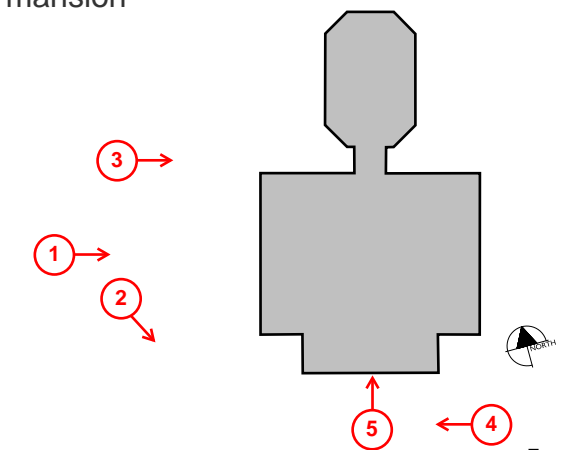

# LEGEND

- Existing Accessible Brick Walking Path
- Existing Bluestone Walking Path / Plaza
- New Bluestone Pavement
- New Brick Pavement

Accessible Route

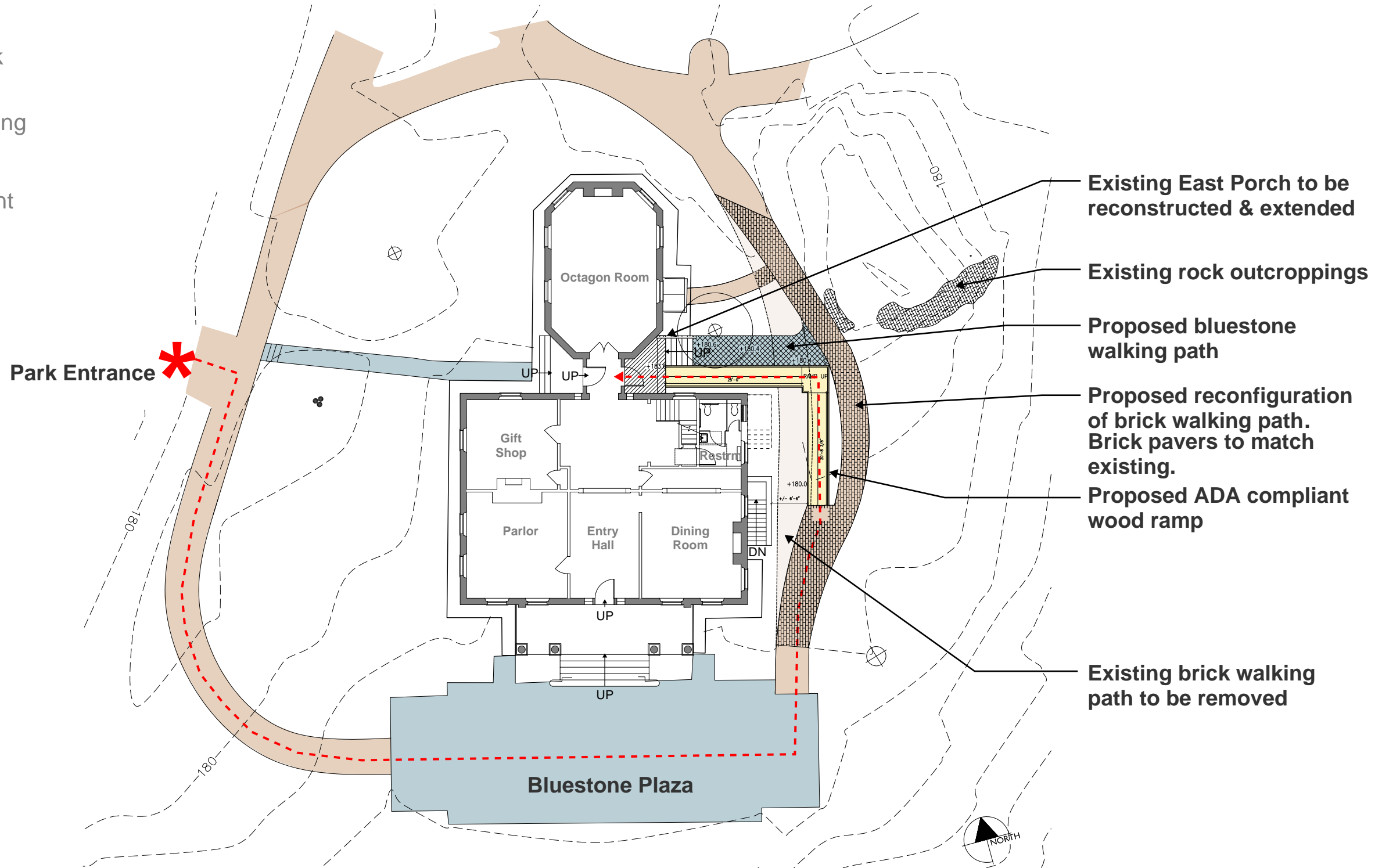

Proposed Site Plan





6. View of East Elevation at location of proposed ramp



7. View of approach to East Entrance at location of proposed ramp



8. View of approach to East Entrance from South side of mansion and bluestone plaza. Note adjacent grade change and rock outcropping

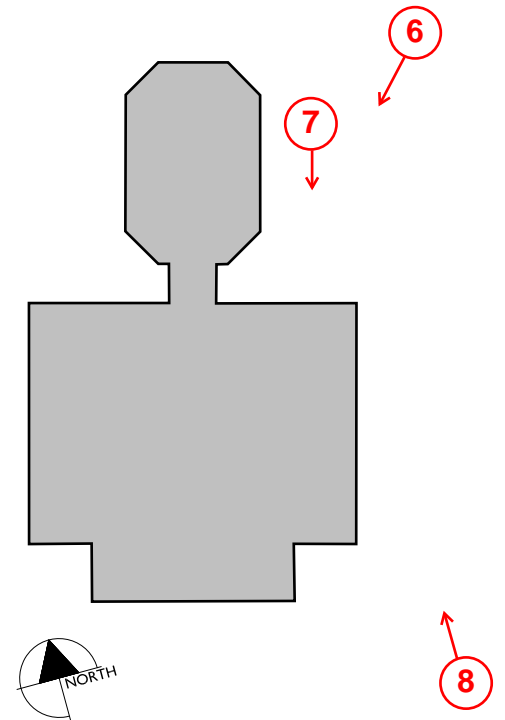



16. View of West side of South porch.  
Note: Pitch of the existing porch exceed the maximum slope for an ADA accessible approach.



17. View of main entrance at South Elevation. Note the additional step at the main entrance door.

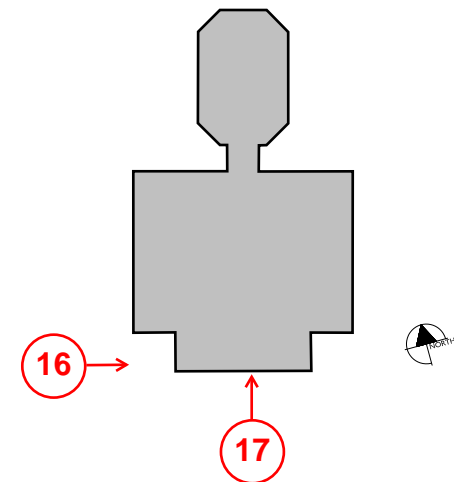



9. View of Southern end of East Elevation, Existing Conditions



10. View of East Elevation, Existing Conditions



11. View of East Elevation, Existing Conditions

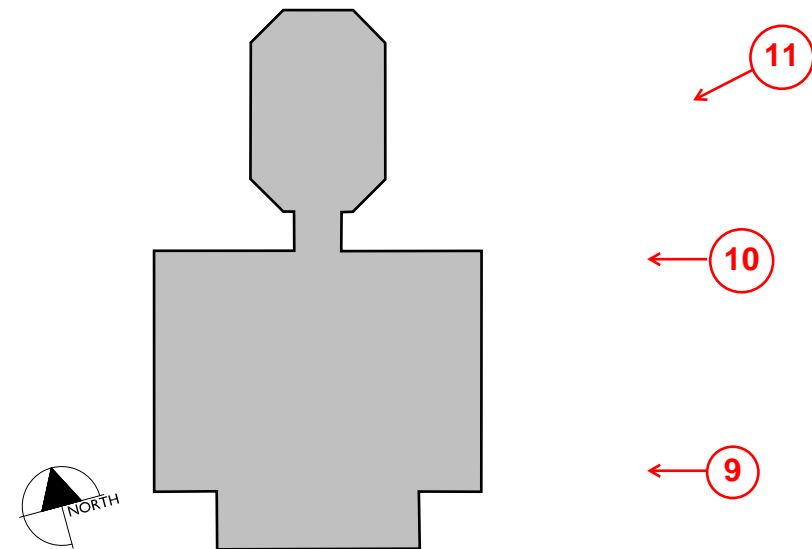



12. View of Southern end of East Elevation, Existing Conditions

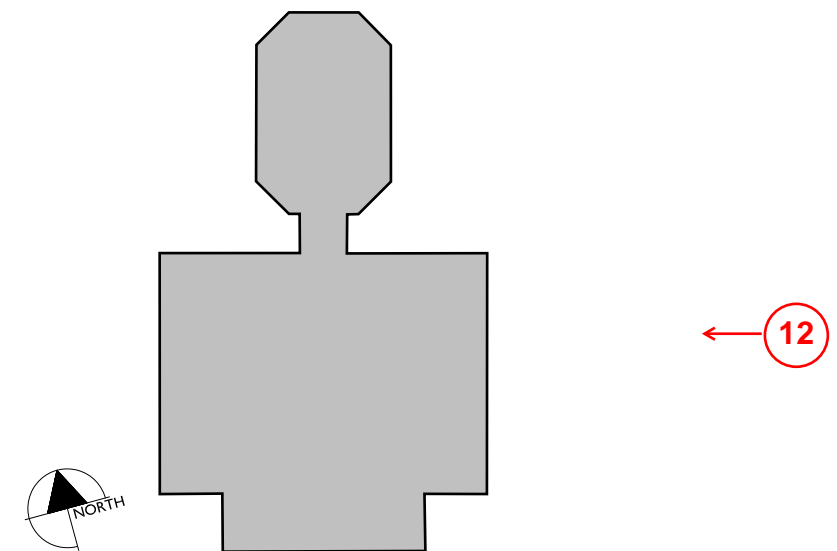



13. View of approach to East Entrance at location of proposed ramp



14. View of East walking path at location of proposed ramp

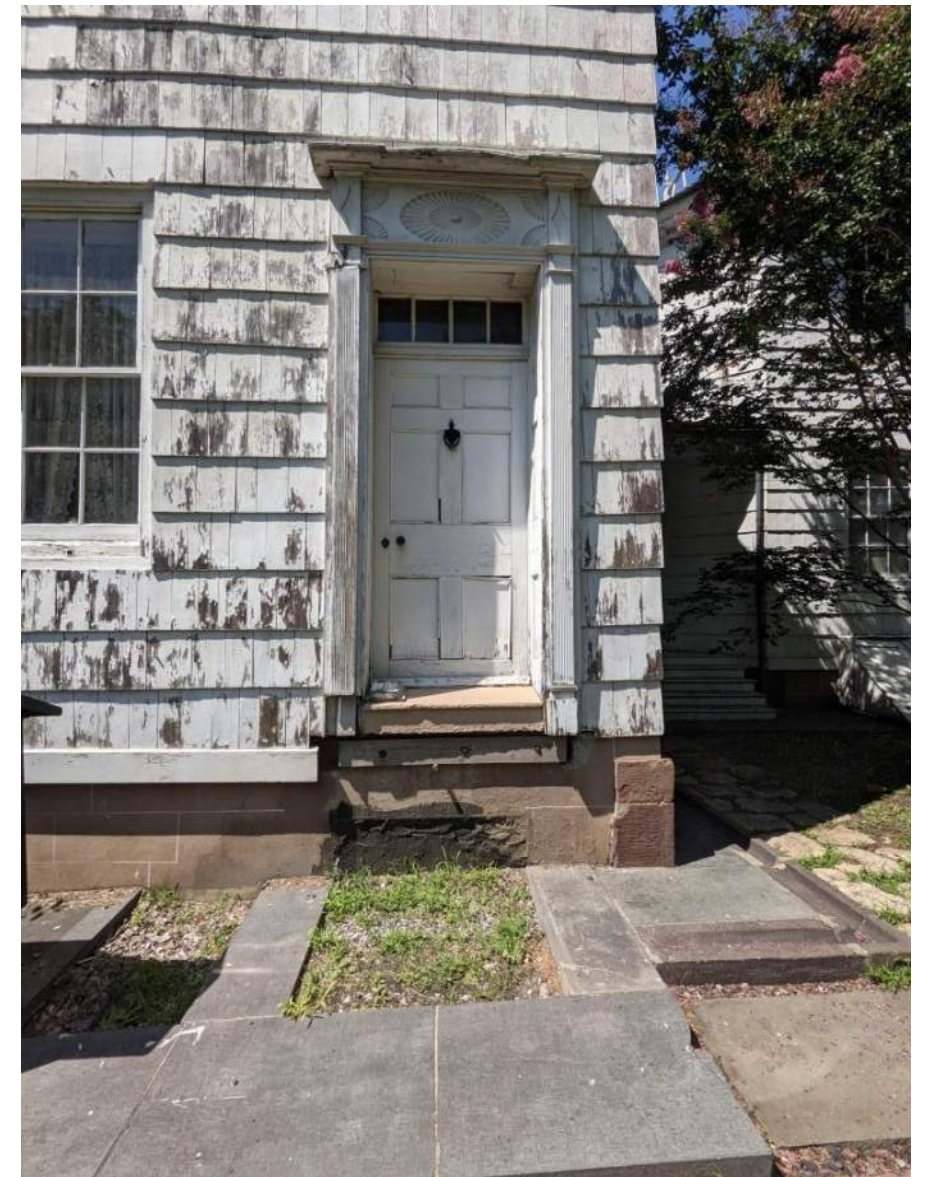

15. View of secondary entrance at location of proposed ramp

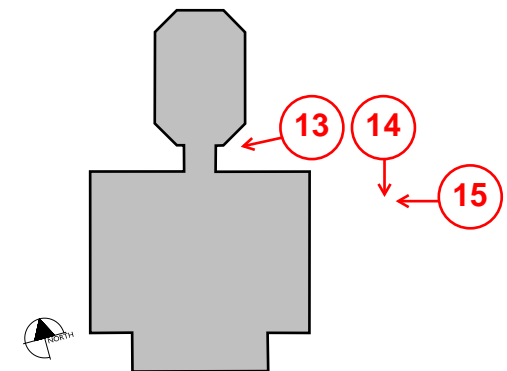

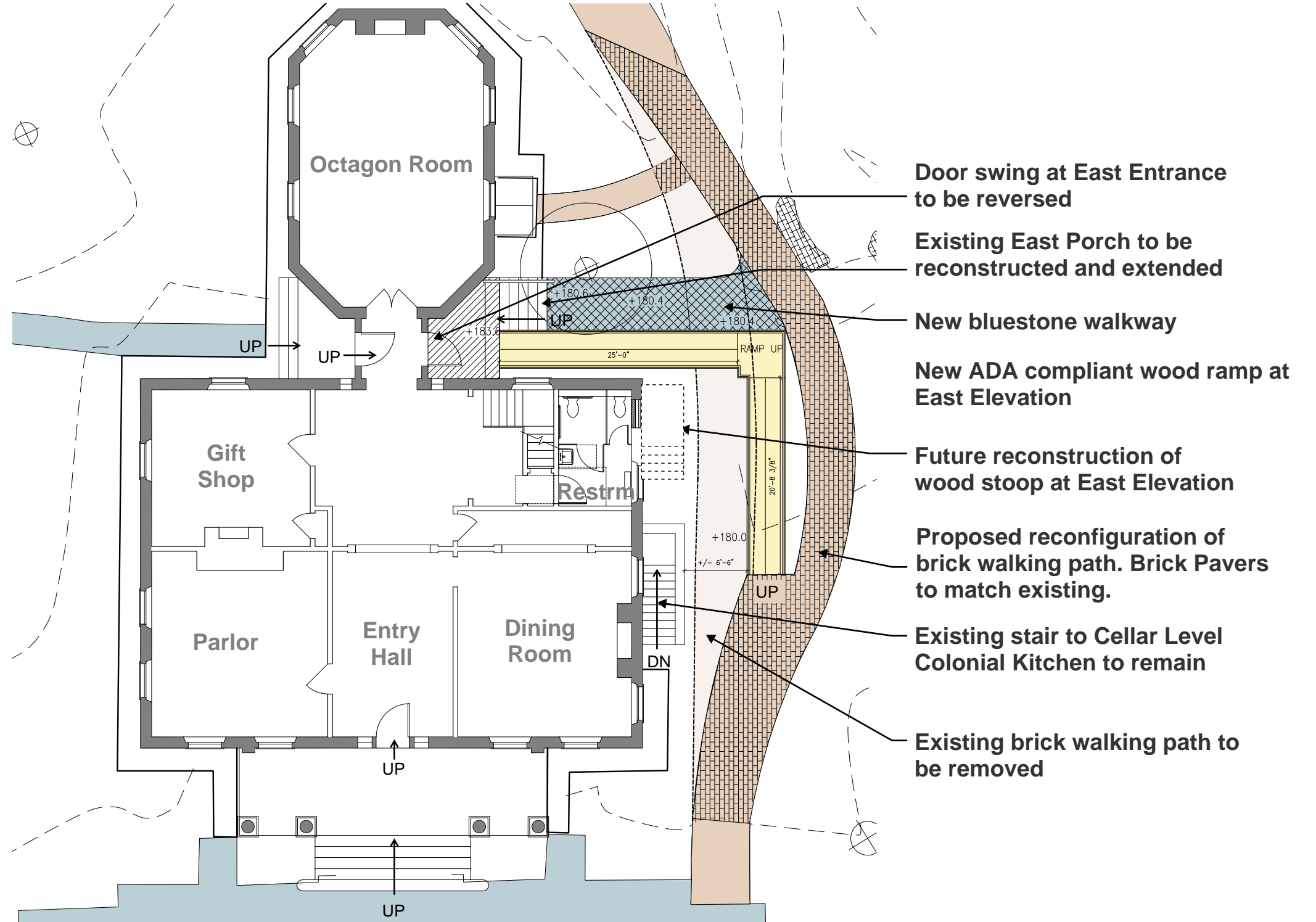

Door swing at East Entrance to be reversed

Existing East Porch to be reconstructed and extended

New bluestone walkway

New ADA compliant wood ramp at East Elevation

Future reconstruction of wood stoop at East Elevation

Proposed reconfiguration of brick walking path. Brick Pavers to match existing.

Existing stair to Cellar Level Colonial Kitchen to remain

Existing brick walking path to be removed

**Proposed First Floor Plan**





**Existing East Elevation**

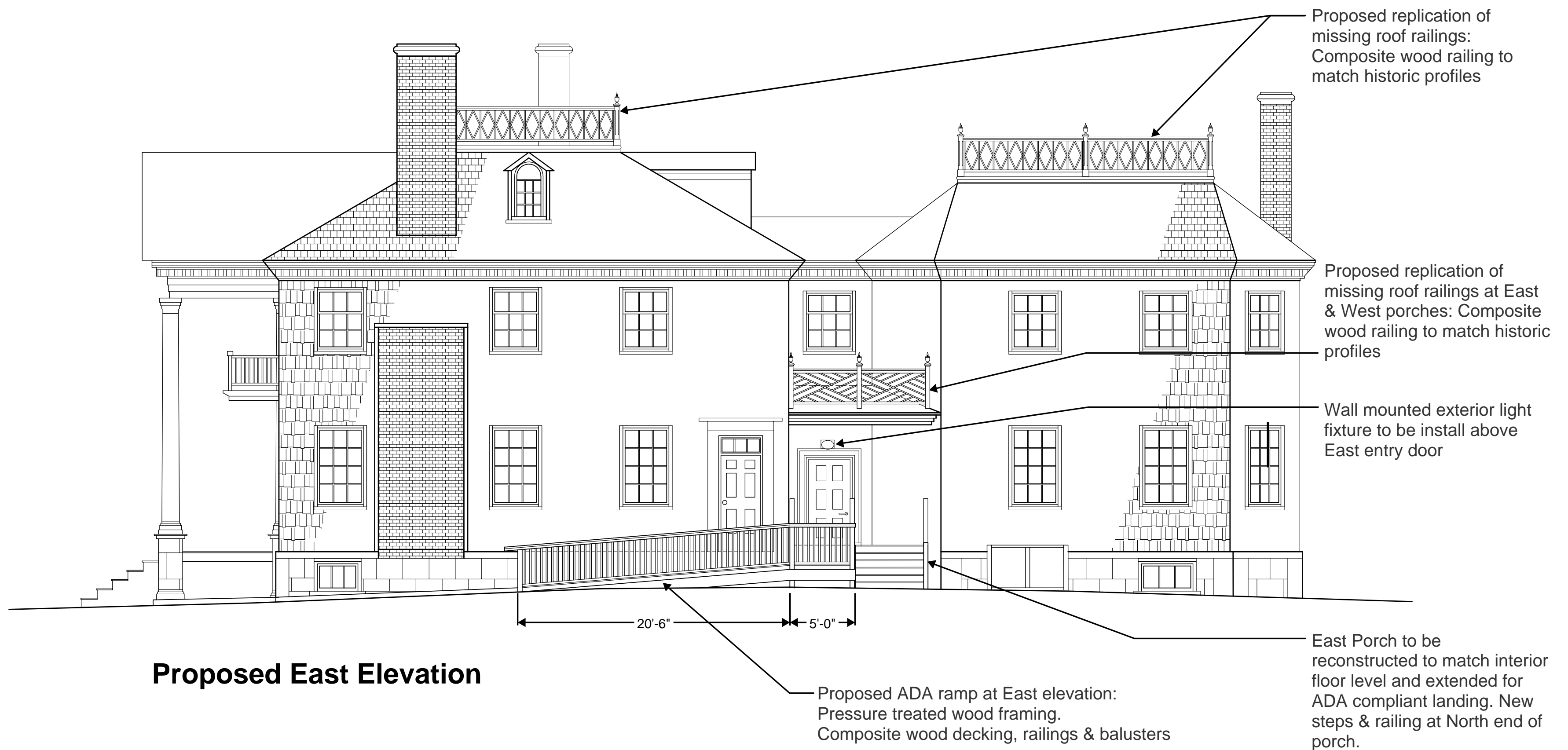

**Proposed East Elevation**



**Existing North Elevation**

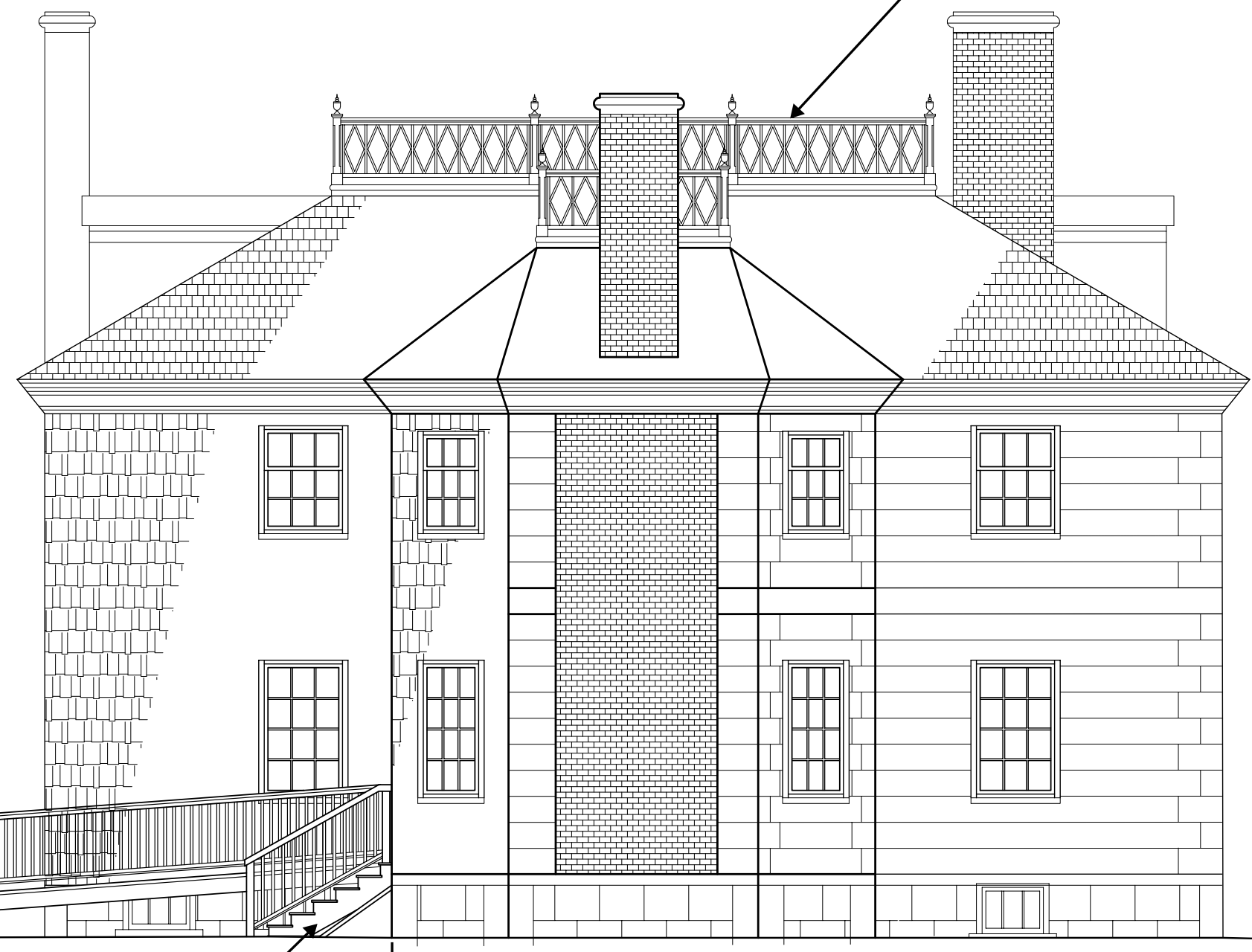

**Proposed North Elevation**

Proposed replication of missing roof railings: Composite wood railing to match historic profiles

Proposed ADA ramp at East elevation:  
Pressure treated wood framing.  
Composite wood decking, railings &  
balusters

Proposed rubble masonry retaining wall

Location of reconfigured brick walking path

Proposed wood steps & railing at North end of East Porch, 6 risers

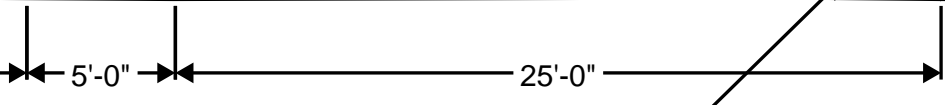

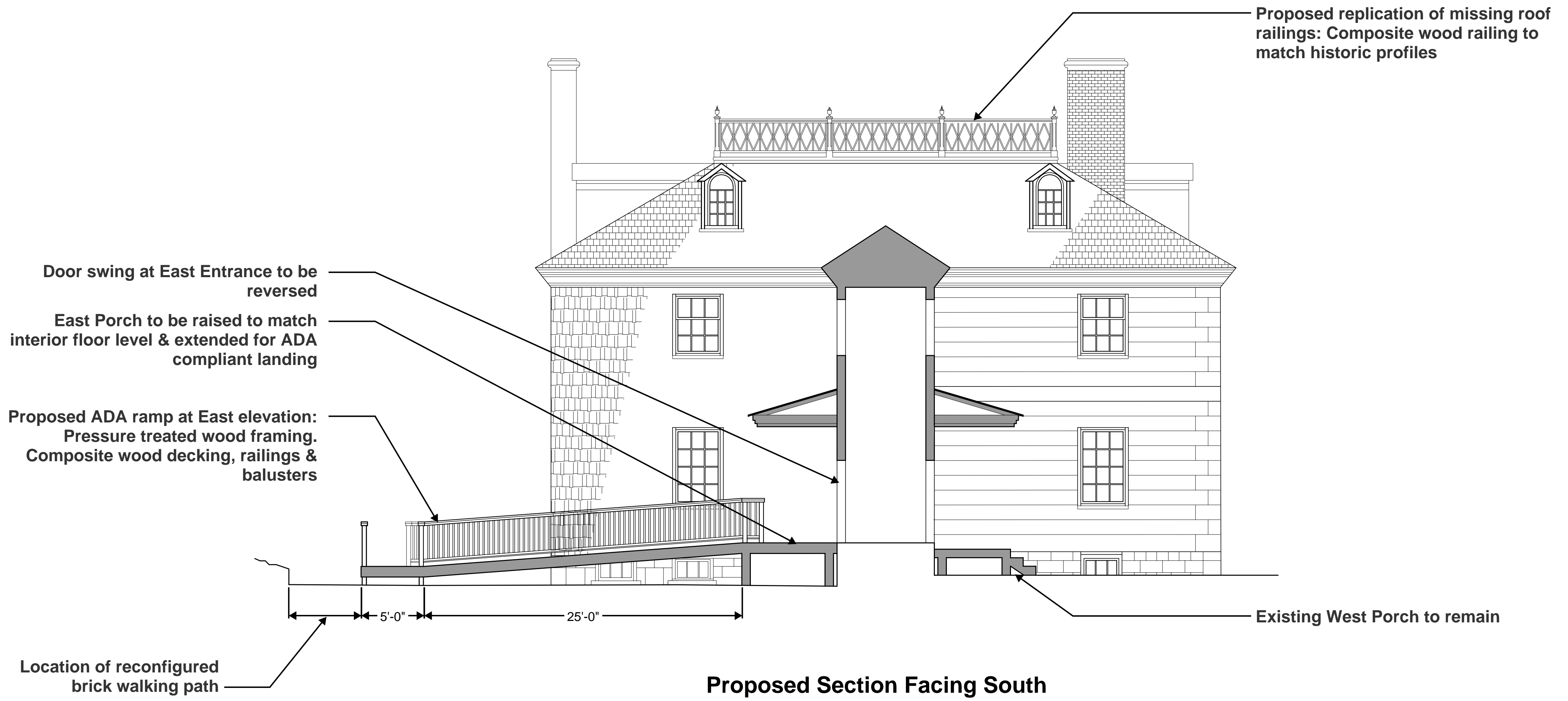



**Existing South Elevation**

Proposed replication of missing  
roof railings: Composite wood  
railing to match historic profiles



**Proposed South Elevation**





**Existing West Elevation**

Proposed replication of missing roof railings: Composite wood railing to match historic profiles

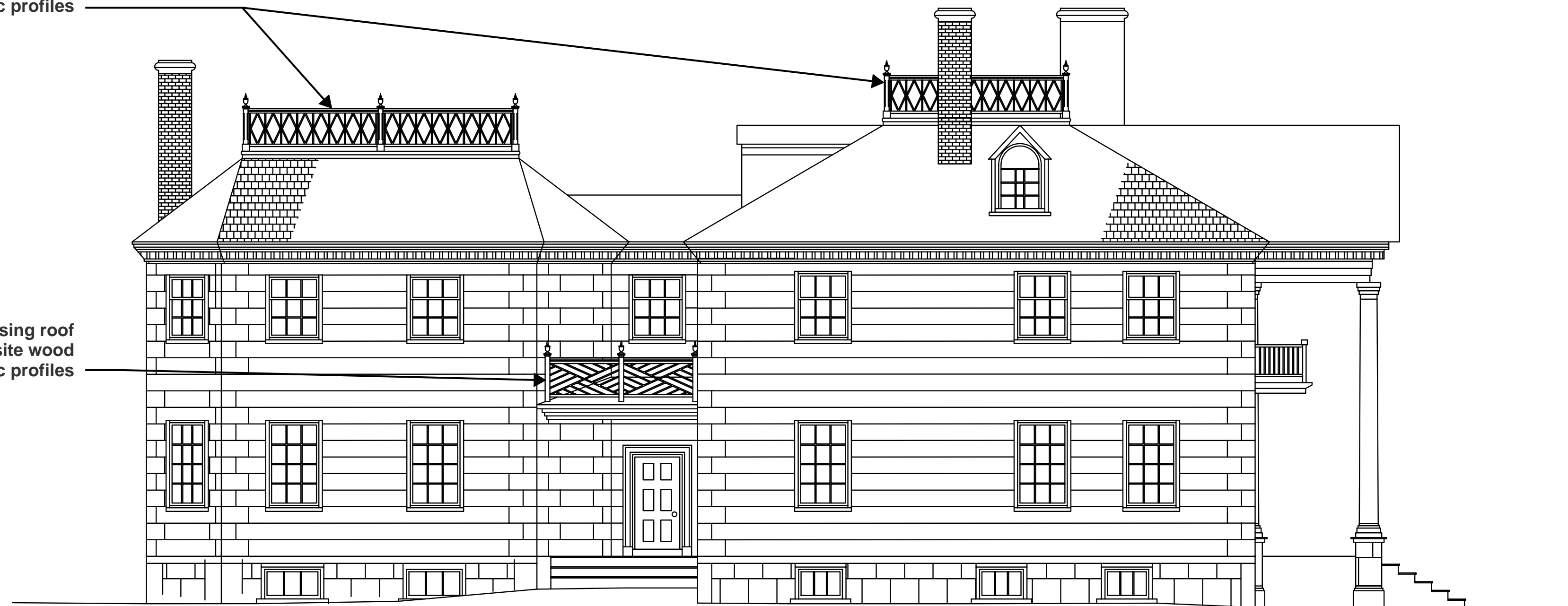

Proposed replication of missing roof railings at West Porch: Composite wood railing to match historic profiles

**Proposed West Elevation**



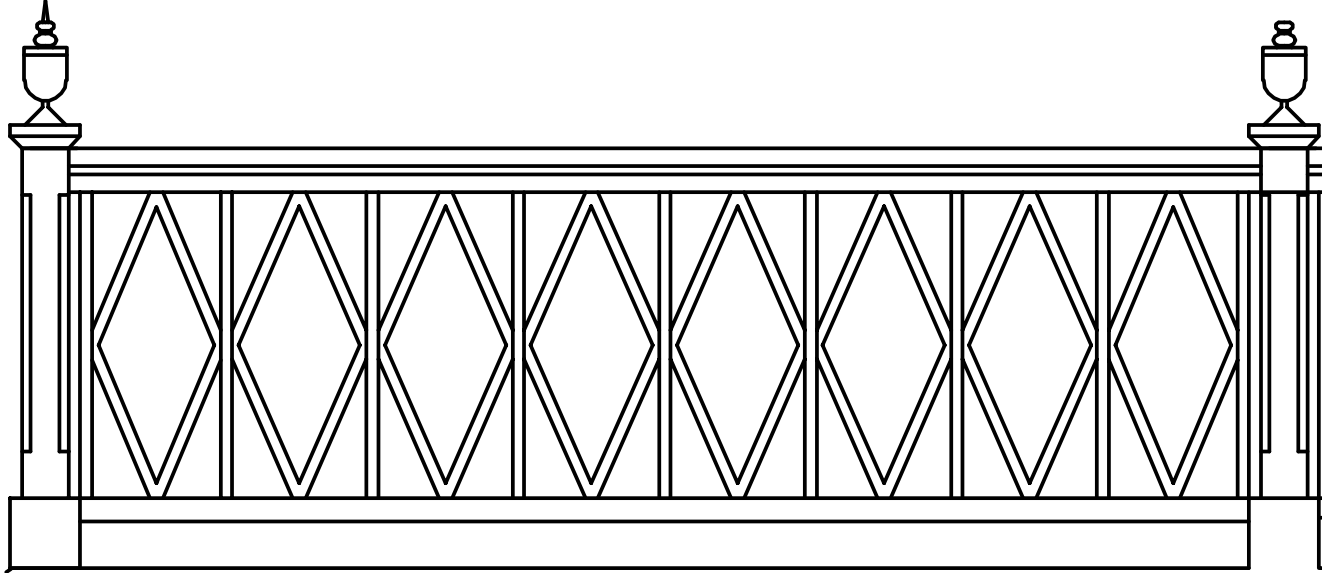

**Detail of Proposed Roof Railing Assembly, Main Roof & Octagon Wing**  
Composite wood railing to match historic profile and dimensions



Engraving of the West Elevation. Note the roof railings at the Main Block, Octagon Wing & Hyphen C. 1854, NYPL



Aerial view of missing roof railings, C. 1934, Olmsted Archives



Aerial view of the Morris-Jumel Mansion & roof railings from the Southwest. 1936. Library of Congress, Prints & Photographs Division, HABS NY,31-NEYO,51



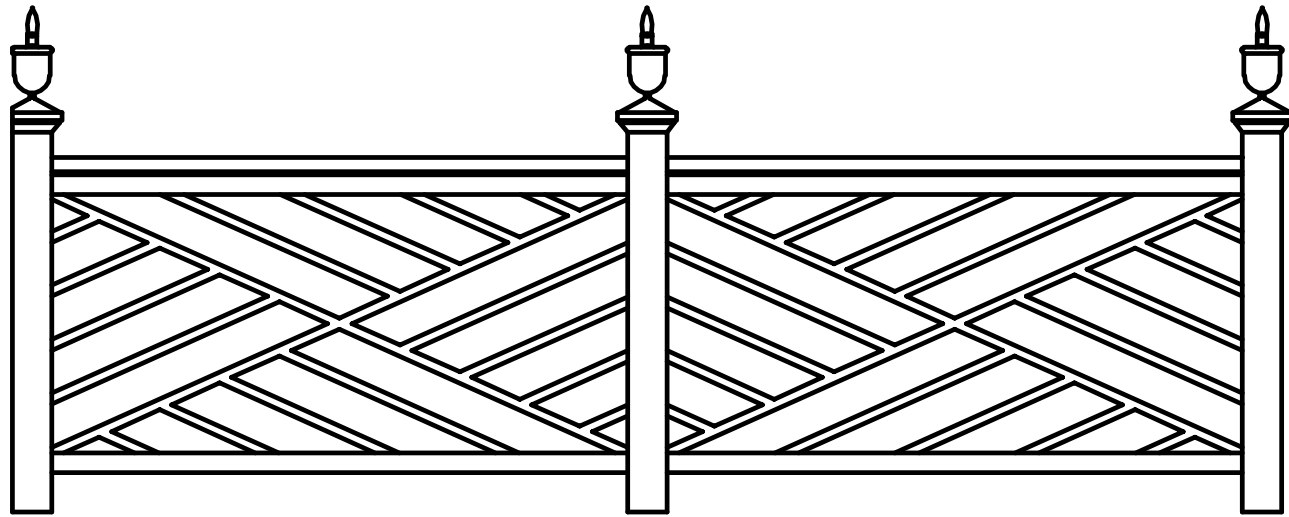

**Detail of Proposed Hyphen Railing Assembly, East & West Porches**  
Composite wood railing to match historic profile and dimensions



View from the Northwest, Note the roof railings at the Main Block, Octagon Wing & Hyphen. C.1936. Olmsted Archives



Aerial view of missing roof railings, C. 1934, Olmsted Archives

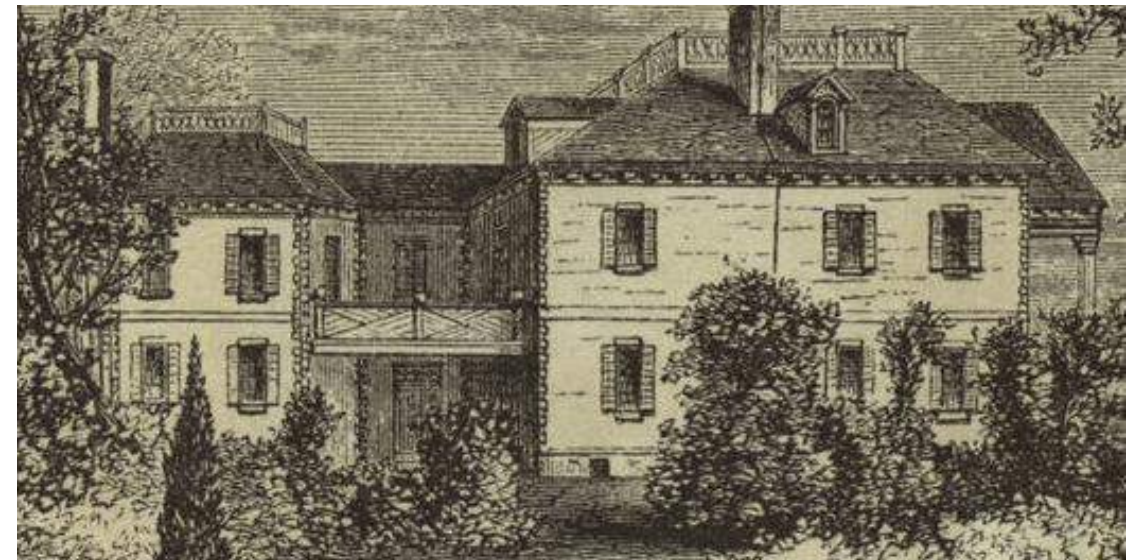

Engraving of the West Elevation, Note the roof railings at the Main Block, Octagon Wing & Hyphen. C. 1876, NYPL



COMPOSITE WOOD ROOF  
RAILING ASSEMBLY W/  
CONCEALED FASTENERS  
TO MATCH EXISTING

1" SQUARE DECORATIVE  
BALUSTERS TO MATCH  
EXISTING

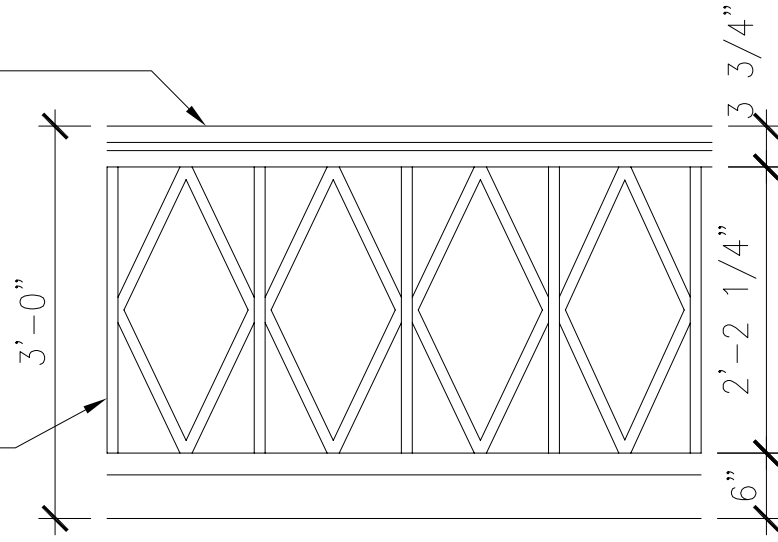

**Proposed Roof Railing Assembly**

Existing railing to be replicated in composite wood.  
All dimensions & profiles to match existing

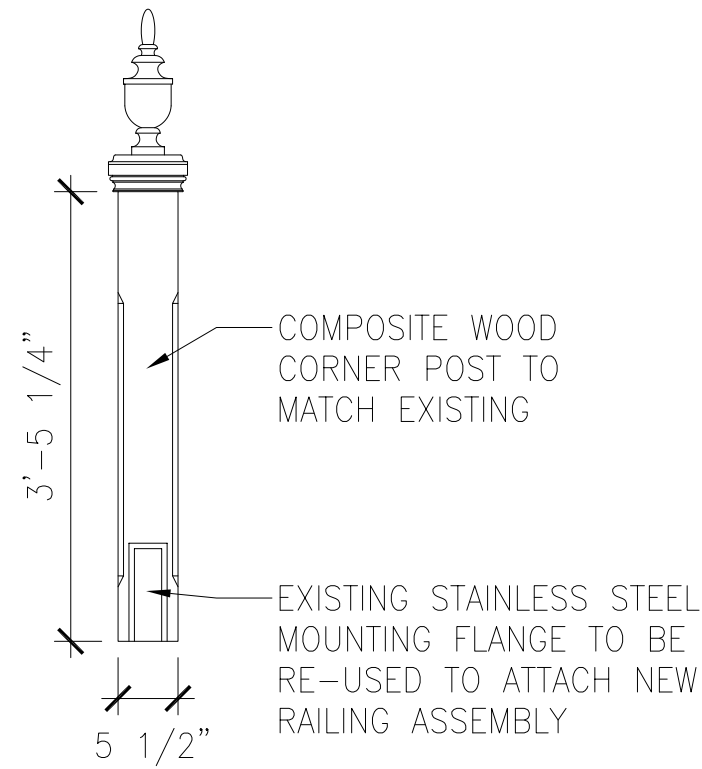

**Corner Post**

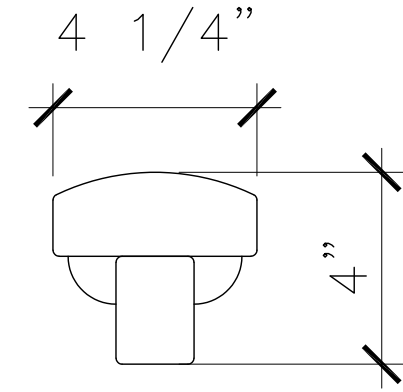

**Handrail**

COMPOSITE WOOD ROOF  
RAILING ASSEMBLY W/  
CONCEALED FASTENERS TO  
MATCH HISTORIC RECORD

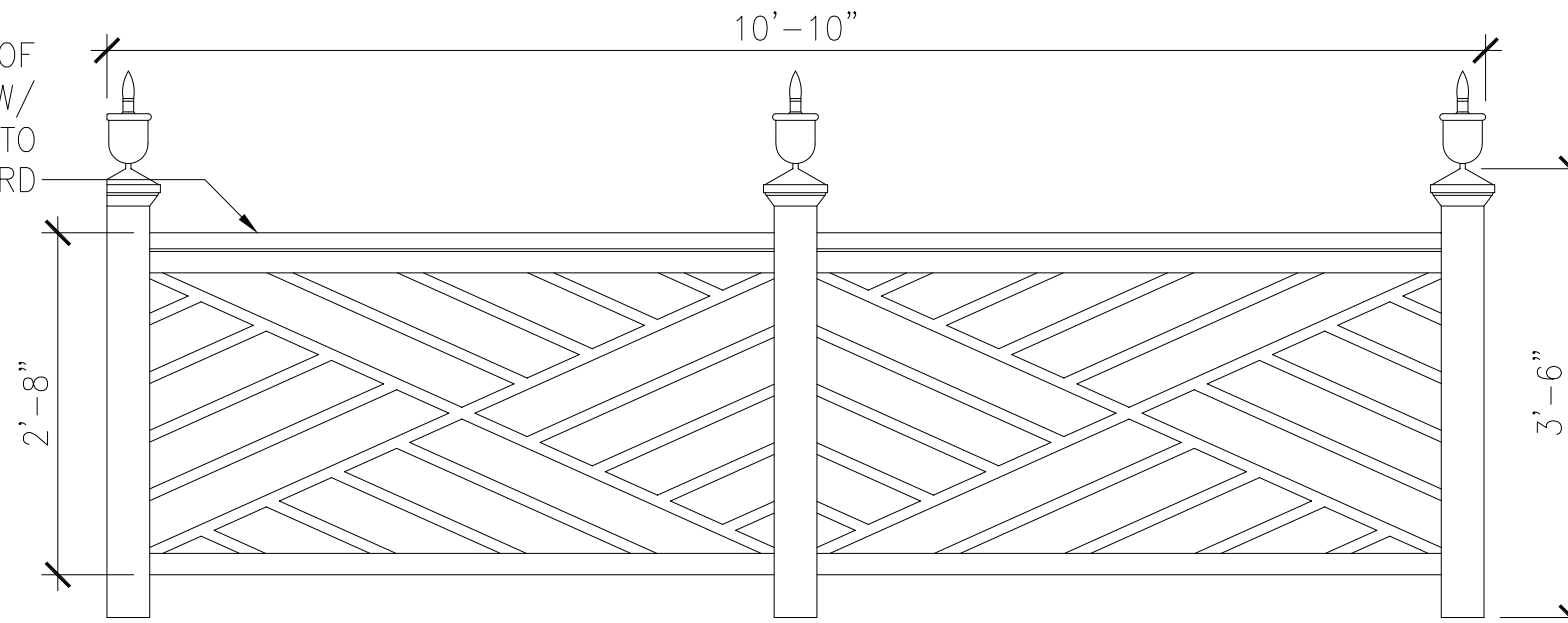

**Proposed Hyphen / Porch Railing Assembly**

Railings to be fabricated in composite wood to  
match historic record



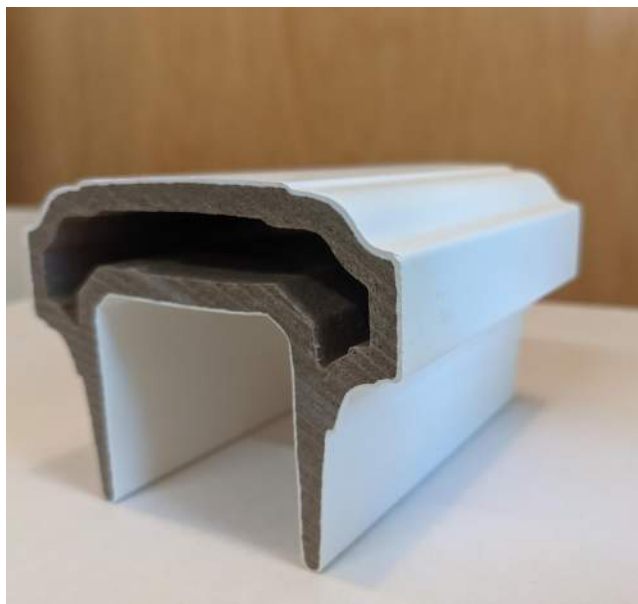

Sample of Proposed Composite Wood Railing,  
Ramp & Roof Railings



Proposed Concealed Exterior Lighting at Ramp



Sample of Proposed Composite Wood Decking  
Proposed Material for ADA Ramp Decking



Examples of Installed Composite Railing Assemblies





View of Proposed ADA Ramp Facing North





View of Proposed ADA Ramp & Replicated Roof Railings Facing East



**The Morris-Jumel Mansion**  
Exterior Restoration & ADA Accessibility Upgrade

The current proposal is:

Preservation Department – Item 9, LPC-22-11104

**65 Jumel Terrace – Morris-Jumel Mansion - Individual and  
Interior Landmark – Jumel Terrace Historic District  
Borough of Manhattan**

To Testify Please Join Zoom

**Webinar ID:** 868 9794 8074

**Passcode:** 501977

By Phone: 1 646-558-8656 US (New York)

877-853-5257 (Toll free) US

888 475 4499 (Toll free)

**Note:** If you want to testify on an item, join the Zoom webinar at the agenda’s “Be Here by” time (about an hour in advance). When the Chair indicates it’s time to testify, “raise your hand” via the Zoom app if you want to speak (\*9 on the phone). Those who signed up in advance will be called first.