

**FIRE DEPARTMENT • CITY OF NEW YORK**



**STUDY MATERIAL FOR THE EXAMINATION FOR  
THE CERTIFICATE OF FITNESS FOR**

**FIRE ALARM SYSTEMS INSPECTION, TESTING AND SERVICE  
TECHNICIAN**

**S-98**

ALSO INCLUDED IN THIS BOOKLET YOU WILL FIND THE FOLLOWING:

NOTICE OF EXAMINATION (NOE)

© 08/2012 New York City Fire Department - All rights reserved ®

Official use (Cpgs:41-43)

## **NEW MAJOR UPDATES TO S-98 TEST AND STUDY MATERIAL**

\*On **April 1, 2026**, the new updated test for S98 Fire Alarm Systems Inspection, Testing and Service Technician will go into effect.

The test questions have been refined as follows:

- updated to clearly reflect the knowledge and responsibilities required of technicians performing these duties only.
- updated requirements and functions with the most current codes, rules, and regulatory updates.
- questions have been revised to reflect current standards and practices.

The previous test and study guide have been revised using the following documents, which are now reflected in the updated test questions:

1. **NYC 2022 Fire Code and 2023 Fire Rules**
2. **NFPA 72–2016** (National Fire Protection Association)
3. **FDNY Information Bulletin** (Fire Alarm Inspection Unit)  
<https://www.nyc.gov/site/fdny/codes/reference/bulletins.page>

### 2020

- [#02-09/2020 Revision 1 - Filing procedures for requesting expedited FA Plan Examination Unit Reviews](#) (PDF)
- [#01-09/2020 Filing procedures for “Core and Shell” Installations](#) (PDF)
- [#12-01/2013 Secondary Fire Command Center Guidelines \(revised\)](#) (PDF)

### 2019

- [#03-01/2019 Locations of Fire Command Centers](#) (PDF)

### 2012

- [#08-02-12 Mounting Height for Fire Alarm Equipment](#) (PDF)
- [#01-03-12 Modification of Fire Alarm Signaling](#) (PDF)

4. **NYC 2025 Electrical Code** (Check the study guide for the required section)
5. **NYC 2022 Building Code** (Check the study guide for the required section)

Please note that from all the materials listed above, the only document you will receive during the exam as a reference material is **NFPA 72–2016 and Pages (41-43)**

All other materials must be read and studied in advance prior to taking the exam.

You are strongly advised to review all materials thoroughly, including NFPA 72–2016. The reference copies provided during the exam are intended only for reference.

## **Table of Contents**

NEW MAJOR UPDATES TO S-98 TEST AND STUDY MATERIAL .....	2
EXAM SPECIFIC INFORMATION FOR S-98 CERTIFICATE OF FITNESS .....	4
REQUIREMENTS FOR CERTIFICATE OF FITNESS APPLICATION.....	4
PART 1. INTRODUCTION.....	9
PART 2. DEFINITIONS.....	10
PART 3. RECORD KEEPING .....	13
PART 4. OUT-OF-SERVICE PROTOCOLS .....	14
PART 6. PARTIAL RELEVANT CODE SECTIONS .....	19
6.1 Fire Code .....	19
6.1.1 Section FC 901 – General .....	19
6.1.2 Section FC 907 – Fire Alarm & Detection Systems.....	22
6.2 Fire Rules.....	24
6.2.1 Section § 104-4 Certification of Corrected Defects in Fire Alarm System Installations.....	24
6.2.1 Section § 105-01 Approval of Fire Alarm System Installations.....	29
6.2.2 Section § 907-01 Fire Alarm Recordkeeping, Smoke Detector Maintenance, Testing and Recordkeeping, and the Prevention of unnecessary and Unwarranted Fire Alarms. ....	32
6.3 Fire Department Information Bulletins (Fire Alarm Inspection Unit) .....	36
6.4 NFPA 72-2016 National Fire Alarm Code .....	36
6.5 NYC 2025 Electrical Code .....	36
6.5.1 EC SECTION 780.33.....	36
6.5.1 EC SECTION 760.41.....	37
6.5.2 EC SECTION 760.49.....	39
6.5.3 EC SECTION 760.131.....	40
6.7 Unit Measurement and Formulas .....	41
6.8 Resistor Color Code.....	43
6.9 Common Defects for Installation, Testing and Servicing Fire Alarm Systems .....	45
PART 7. LITHIUM-ION BATTERY SAFETY.....	46
NEW S-98 - LIST OF MAJOR CHANGES .....	49

## **EXAM SPECIFIC INFORMATION FOR S-98 CERTIFICATE OF FITNESS**

***Save time and submit applications online!***

***All applicants are required to apply and pay for an exam online before arriving at FDNY. It can take about 30 minutes to complete.***

Simplified instructions for online application and payment can be found here:

<http://www1.nyc.gov/assets/fdny/downloads/pdf/business/fdny-business-cof-individuals-short.pdf>

This book is provided to the public for free by FDNY.

Create an Account and Log in to:

<http://fires.fdnyccloud.org/CitizenAccess>

## **REQUIREMENTS FOR CERTIFICATE OF FITNESS APPLICATION**

### **General requirements:**

Review the General Notice of Exam:

<http://www1.nyc.gov/assets/fdny/downloads/pdf/business/general-notice-of-exam-cof.pdf>

### **Special requirements for the S-98 Certificate of Fitness:**

- Applicants must be employed by FDNY approved companies for Fire Alarm Company. The approved fire alarm company list:

<https://www1.nyc.gov/assets/fdny/downloads/pdf/business/approved-companies-fire-alarm-system-inspection-testing-service.pdf>

- Applicants are limited to hold one S-98 COF per company. FDNY may allow more than one certificate (S-98), **ONLY** if the additional company is owned by the same principal(s). The applicant must submit a notarized correspondence on company letterhead stating all pertinent information regarding the related ownership of the companies. The FDNY may require further proof of ownership if necessary.
- Applicants must be employed by an FDNY S-97 certificate holding company. The applicant must present a letter of recommendation from their S-97 employer that includes the applicant's full name, experience and work address and must be on official letterhead. Applicants must provide proof of at least three (3) years of full-time experience in the programming, testing, inspection or servicing of fire alarm systems and signed by his/her current S-97 certified employer.

## **Application Fee**

The application fee is **\$25**. Applicants must apply online and submit payment using one of the following methods:

- **Credit card:** American Express, Discover, MasterCard, or Visa
- **Debit card:** MasterCard or Visa
- **Personal or company check or money order** (made payable to the **New York City Fire Department**)
  - Applicants choosing this option must apply online and submit payment in person at FDNY.

A **2% convenience fee** will be applied to all credit card payments.

For fee waivers submit: ***(Only government employees who will use their COF for their work-related responsibilities are eligible for fee waivers.)***

- A letter requesting fee waiver on the Agency's official letterhead stating applicant full name, exam type and address of premises; **AND**
- Copy of identification card issued by the agency

## **REQUIREMENTS FOR ALTERNATIVE ISSUANCE PROCEDURE (AIP)**

The S-98 Certificate of Fitness can be obtained by the alternative issuance procedure. Qualified applicants should review and complete the S-98 Certificate of Fitness Alternative Issuance Procedure Application Affirmation Form:

<http://www1.nyc.gov/assets/fdny/downloads/pdf/business/cof-s98-aip.pdf>

The AIP applicants must submit the application, required documents and payment on **FDNY Business**:

<http://fires.fdnyccloud.org/>

## **EXAM INFORMATION**

The **S-98** exam will consist of **80** multiple-choice questions, administered on a "touch screen" computer monitor. It is a time-limit exam. Based on the amount of the questions, you will have 160 minutes to complete the test. A passing score of at least 70% is required to secure a Certificate of Fitness.

**It is critical that you read AND understand the S-98 booklet and NFPA 72 (2016) before taking the exam to help increase your chance of passing this exam.**

**For additional information:** Phone: 311 | [FDNY.BusinessSupport@fdny.nyc.gov](mailto:FDNY.BusinessSupport@fdny.nyc.gov) | [nyc.gov/fdny](http://nyc.gov/fdny)

*Special material provided during the exam:* A copy of relevant sections of NFPA 72 (2016) and a calculator will be provided during your exam. This study material, however, will NOT be provided during your exam.

Please always check for the latest revised booklet at FDNY website before you take the exam.

<http://www1.nyc.gov/assets/fdny/downloads/pdf/business/cof-s98-noe-study-materials.pdf>

**EXAM SITE:**      **FDNY Headquarters, 9 MetroTech Center, Brooklyn, NY. Enter through the Flatbush Avenue entrance (between Myrtle Avenue and Tech Place).**

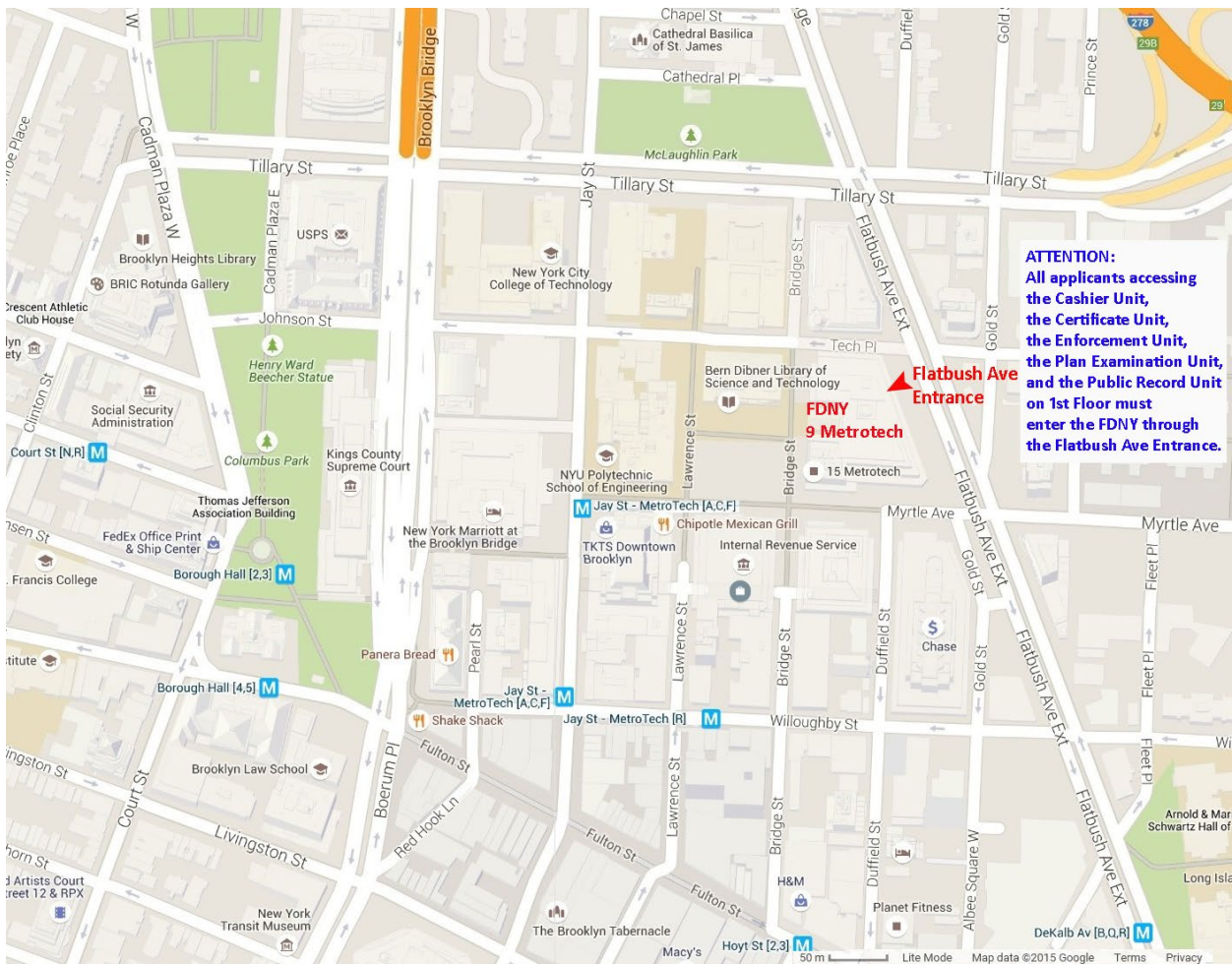

**ATTENTION:**  
All applicants accessing the Cashier Unit, the Certificate Unit, the Enforcement Unit, the Plan Examination Unit, and the Public Record Unit on 1st Floor must enter the FDNY through the Flatbush Ave Entrance.

## **RENEWAL REQUIREMENTS**

**General renewal requirements:**

Review the General Notice of Exam:

<http://www1.nyc.gov/assets/fdny/downloads/pdf/business/general-notice-of-exam-cof.pdf>

**Special renewal requirements. S-98 Certificate of Fitness: None**

## **QUESTIONS?**

**FDNY Business Support Team:** For questions, call 311 and ask for the FDNY Customer Service Center or send an email to [FDNY.BusinessSupport@fdny.nyc.gov](mailto:FDNY.BusinessSupport@fdny.nyc.gov)

### **STUDY MATERIAL AND TEST DESCRIPTION**

#### **About the booklet**

This study material will help you prepare for the written examination for the Certificate of Fitness (**C of F**) for the Fire Alarm Systems Inspection, Testing and Service Technician (**S-98**). The study materials include information taken from the 2022 New York City Fire Code (FC) Chapter 9 and Fire Department Rules Chapter 1 and Chapter 9, Building Code Section 907, FD information bulletin and applicable NFPA Standard 72, 2016 Edition Inspection, Testing and Maintenance, NYC Electrical Code (2025 edition). **It is critical that you read AND understand this booklet and NFPA 72 (2016) to help increase your chance of passing this exam.**

#### **About the Test**

You must pass an 80-question multiple choice test to qualify for the C of F. A score of 70% correct is required to pass the test. All questions have four answer options. Only **one** answer is correct for each question. If you do not answer a question, or if you mark more than one answer to a single question, your answer to that question will be scored as incorrect. Read each question carefully before marking your answer. There is no penalty for guessing.

**A copy of relevant sections of NFPA 72 (2016) and a calculator will be provided during your test. This study material, however, will NOT be provided during your test.**

#### **SAMPLE EXAM QUESTIONS**

*The following questions represent the “format” of the exam questions, not the content of the real exam.*

**1. Which of the following are allowed to be used while taking a Certificate of Fitness examination at 9 Metro Tech Center?**

- I. cellular phone
- II. study material booklet
- III. reference material provided by the FDNY
- IV. mp3 player

- A. III only
- B. I, II, and III
- C. II and IV
- D. I only

Only reference material provided by the FDNY is allowed to be used during Certificate of Fitness examinations. Therefore, the correct answer would be A. You would touch "A" on the computer terminal screen.

**2. If the screen on your computer terminal freezes during your examination, who should you ask for help?**

- A. the person next to you
- B. the firefighters in the testing room
- C. the examiner in the testing room
- D. the computer help desk

If you have a computer-related question, you should ask the examiner in the testing room. Therefore, the correct answer would be C. You would touch "C" on the computer terminal screen.

**3. If you do not know the answer to a question while taking an examination, who should you ask for help?**

- A. the person next to you.
- B. the firefighters in the testing room.
- C. the examiner in the testing room.
- D. you should not ask about test questions since FDNY staff cannot assist applicants.

You should not ask about test questions or answers since FDNY staff cannot assist applicants with their tests. Therefore, the correct answer would be D. You would touch "D" on the computer terminal screen.

## **PART 1. INTRODUCTION**

The S-98 Certificate of Fitness, FIRE ALARM SYSTEMS INSPECTION, TESTING AND SERVICE TECHNICIAN, was developed in order to certify technicians who program, test, inspect and service fire alarm systems in the City of New York. This certification applies to fire alarm systems as defined in Part 2, which is in the “Definitions” section found in this booklet.

The programming, inspection, testing, and servicing of fire alarm systems, systems initiating devices, and notification appliances shall comply with the requirements of the 2022 NYC Fire Code, Fire Rules 2023, NFPA 72 (2016) and the equipment manufacturer’s recommendations, and verify the correct operation of the fire alarm system. The programming, inspecting, testing and servicing of fire alarm systems shall only be performed by S-97/S-98 Certification of Fitness holders. S-95 or F-58 (FSD) C of F holders are **ONLY** allowed to perform the daily visual inspections, the monthly manual fire alarm activation test and maintain the logbook.

Technicians applying for the S-97/S-98 Certificate of Fitness shall be familiar with NFPA 72 (2016), the 2022 NYC Fire (FC) and Building Codes, the Rules of the City of New York (FR), NYC Electrical Code, and FDNY Fire Alarm Bulletins that are applicable to their performance within the scope of the S-97/S-98 Certificate of Fitness. The comprehensive examination offered by the FDNY is based on these books and documents.

An S-97/S-98 Certificate of Fitness holder must be present at any FDNY Fire Alarm System test and inspection. The holder must make an entry in the premise logbook, including the holder’s name, Certificate of Fitness number, employer, as well as record the purpose of the visit and its official outcome.

The FDNY certifies individuals in different aspects of fire alarm maintenance. There are 3 Certificate of Fitness categories: S-78(citywide inspection, cleaning & testing of smoke detectors), F-78 (premises related to inspection, cleaning & testing of smoke detectors, and S-97/S-98 (Fire Alarm Systems Inspection, Testing and Service Technician). The scope for each of the Certificates is different, and it is critical to know the limitations of each. Holders of the S-97/S-98 may perform the responsibilities of holders of the S-78/F-78 Certificates of Fitness; however, S-78/F-78 holders cannot perform all the functions of a S-97/S-98 holder (see the chart on next page). S-95 is the Certificate of Fitness for Fire Alarm Supervision.

C of F Holder Duties		May be performed by		
		S-78/F-78	S-95	S-97/S-98
1.	Smoke detector visual inspection	Yes	Yes	Yes
2.	Smoke detector inspections, testing, cleaning and maintenance	Yes	NO	Yes
3.	Program, service, cleaning, testing, repair and/or replacement of low voltage fire alarm system components	NO	NO	Yes

## PART 2. DEFINITIONS

**ACCESSIBILITY:** As defined in NFPA admitting close approach: not guarded by locked doors, elevation, and other effective means.

**ALARM NOTIFICATION APPLIANCE:** A fire alarm system component, such as a bell, horn, speaker, light, text display or vibration device that issues an audible, tactile, and/or visual alert.

**ALARM SIGNAL:** A signal indicating an emergency requiring immediate action, such as a signal indicative of fire.

**ANNUNCIATOR:** A unit containing one or more indicator lamps, alphanumeric displays, or other equivalent means in which each indication provides status information about a circuit, condition or location.

**AUTOMATIC:** As applied to fire protection devices, any device, equipment or system that initiates system function as a result of a predetermined temperature rise, rate of temperature rise, or combustion products, without the necessity for human intervention.

**APPROVED CENTRAL STATION COMPANY:** A central station company that has been issued a valid certificate of operation from FDNY.

**ARCS (Auxiliary Radio Communications System):** In-Building Emergency Radio Communication Systems. ARC system is a wireless two-way building communication system for Fire Department use only.

**CENTRAL STATION COMPANY:** A person or entity engaged in the operation of a central station.

**CENTRAL STATION SIGNALING SYSTEM:** A system comprised of the protective signaling system at the protected premises, the central station physical plant, the exterior communications channels, and satellite stations, if any.

**CENTRAL STATION:** A facility that receives alarm signals from protected premises and retransmits or otherwise reports such alarm signals to the Fire Department.

**DEDICATED FUNCTION FIRE ALARM SYSTEM (DFS):** A protected premises fire alarm system installed specifically to perform emergency control function(s) where a building fire alarm system is not required.

**DEFINED FIRE ALARM SYSTEM:** A fire alarm system or any sub-system thereof that automatically transmits signals to the department or a central station and that is installed in premises which are required to have a fire alarm system.

**DESIGNATED REPRESENTATIVE:** A person or entity designated by the subscriber who shall be responsible for receiving notifications from the Central Station Company concerning the status of the protective signaling system at the protected premises and who is authorized to take action with respect to such system.

**EMERGENCY ALARM SYSTEM:** A system to provide indication and warning of an emergency conditions involving the release of hazardous materials or other hazardous material incident.

**FIRE ALARM BOX, MANUAL:** A manually operated device used to initiate an alarm signal.

**FIRE ALARM CONTROL UNIT (FACP, FCS):** A system component that receives inputs from automatic and manual fire alarm devices and is capable of supplying power to detection devices and transponder(s) of off-premises transmitter(s). The control unit is capable of providing a transfer of power to the notification appliances and transfer of condition to relays of devices.

**FIRE ALARM SIGNAL:** A signal initiated by a fire alarm-initiating device such as a manual fire alarm box, automatic fire detector, water-flow switch, or other device whose activation is indicative of the presence of a fire or fire signature.

**FIRE ALARM SYSTEM:** Any system, including any interconnected fire alarm sub-system, of components and circuits arranged to monitor and annunciate the status of fire alarm or supervisory signal-initiating devices.

**FIRE DETECTOR, AUTOMATIC:** A device designed to detect the presence of a fire signature and to initiate action.

**FIRE PROTECTION SYSTEM:** Approved devices, equipment and systems or combinations of systems used to detect a fire, activate an alarm, extinguish or control a fire, control or manage smoke and products of a fire or any combination thereof, including fire extinguishing systems, fire alarm systems, sprinkler systems and standpipe systems.

**FIRESTOPPING:** Firestops are fire protection barriers which prevent the spread of fire and smoke. These may enter into openings created in walls and floors because of the installation of electrical, communications, plumbing and ventilation systems. Fire-stopping prevents or significantly limits the spread of fire and smoke by filling the openings with fire resistant material such as fire rated caulks, mortars, putties as well as collars and pillows which expand when exposed to fire or heat. These effectively seal cracks, gaps and other openings. This is very important when containing a fire and is part of an effective fire prevention strategy when combined with fire alarm and fire suppression systems. A few of the nationally recognized independent laboratories which conduct tests of fire stopping materials, devices and systems are Underwriters Laboratories Inc., Omega Point Laboratory and Factory Mutual.

**IMPAIRMENT COORDINATOR:** The person responsible for ensuring that proper safety precautions are taken when a fire protection system is out-of-service.

**INITIATING DEVICE:** A system component that originates transmission of a change-of-state condition, such as in a smoke detector, manual fire alarm box, or supervisory switch.

**INTERMEDIATE FIRE ALARM OR FIRE SUPERVISORY CONTROL UNIT:** A control unit used to provide area fire alarm or area fire supervisory service that, where connected to the proprietary fire alarm system, becomes a part of that system. It is also known as Sub-System or Extension.

**MANDATORY SYSTEM:** A protective signaling system whose installation at a protected premises is required by law.

**MULTIPLE-STATION ALARM DEVICE:** Two or more single-station alarm devices that can be interconnected such that actuation of one causes all integral or separate audible alarms to operate. It also can consist of one single-station alarm device having connections to other detectors or to a manual fire alarm box.

**OUT-OF-SERVICE SYSTEM:** A fire protection system that is not fully functional; or whose operation is impaired or is otherwise not in good working order.

**PLENUM:** The open space that carries air between the ceilings and floor above.

**PROPRIETARY CENTRAL STATION:** A central station operated by or on behalf of the owner of the protected premises monitored by the central station that monitors protected premises other than the premises in which the central station is located. For purposes of this section and R4604-01, unless otherwise specifically provided, reference to “central station company” shall be deemed to include proprietary central stations.

**PRESIGNAL SYSTEM:** A fire alarm system having a feature that allows initial fire alarm signals to sound in a constantly attended central location and for which a human action is subsequently required to achieve a general alarm, or a feature that allows the control equipment to delay the general alarm by more than one minute after the start of the alarm processing.

**PROTECTED PREMISES:** A building, occupancy or structure located in the city that is equipped with a fire alarm system that transmits an alarm signal to the Fire Department or a central station that monitors such system for the purposes of reporting fire alarms to the Fire Department, whether or not the installation of such system on the premises is required by law.

**PROTECTIVE SIGNALING SYSTEM:** A system or device installed at a protected premises and designed to transmit an alarm signal, a supervisory signal or a trouble signal.

**RELEASING FIRE ALARM SYSTEM (RFAS):** A protected premises fire alarm system that is part of a fire suppression system or that provides control inputs to a fire suppression system related to the fire suppression system’s sequence of operations and outputs for other signaling and notification.

**SINGLE-STATION SMOKE ALARM:** An assembly incorporating the detector, the control equipment, and the alarm-sounding device in one unit, operated from a power supply either in the unit or obtained at the point of installation.

**SMOKE ALARM:** A single-or multiple-station alarm responsive to smoke and not connected to a system.

**SMOKE DETECTOR:** A listed device that senses visible or invisible particles of combustion that is connected to a fire alarm system.

**SMOKE DETECTOR MAINTENANCE COMPANY CERTIFICATE:** A certificate issued by the Fire Commissioner to a person engaged in the business of performing smoke detector cleaning and testing, which authorizes such person to engage in such business and supervise the performance of such cleaning and testing by certificate of fitness holders.

**SUPERVISORY SIGNAL:** A signal indicating the need for action in connection with the supervision of guard tours, fire extinguishing systems or equipment, fire alarm systems or the maintenance features of related systems.

**SUPERVISORY SIGNAL-INITIATING DEVICE:** An initiating device, such as a valve supervisory switch, water level indicator, or low-air pressure switch on a dry-pipe sprinkler system, that triggers a supervisory signal.

**TROUBLE SIGNAL:** A signal initiated by the fire alarm system or device indicative of a fault in a monitored circuit or component.

**UNNECESSARY ALARM:** An alarm signal transmitted by a fire alarm system which functioned as designed, but for which a department response proved unnecessary. An example of an unnecessary alarm is an alarm triggered by smoke from a lit cigarette in a non-smoking area, when the presence of such smoke does not implicate fire safety concerns.

**UNWARRANTED ALARM:** An alarm signal transmitted by a fire alarm system which failed to function as designed as a result of improper installation, improper maintenance, malfunction, or other factor. Examples of unwarranted alarms are alarms resulting from improper smoke detector placement, improper detector setting for installed location, lack of system maintenance, and control panel malfunction. It is important to know that the alarm verification feature reduces the number of unwarranted alarms.

**TRANSMITTER:** A component of a protective signaling system that provides the link between a fire alarm system and the transmission channels.

## **PART 3. RECORD KEEPING**

### **901.6.2 Records.**

Records of all system inspections, tests, servicing and other maintenance required by the Fire Code, the Fire Rules or the referenced standards shall be maintained on the premises for a minimum of 3 years and made available for inspection by any FDNY representative.

A central station company shall **test** all paths of communication for the central station signaling system that are not supervised at least once every **24 hours**. A record of such tests shall be maintained in the central station log.

## **RECORDKEEPING**

1. All records required to be maintained under this section shall be entered in a central station log which shall be maintained at each central station.
2. The central station log shall always be available to the Fire Department for inspection. Copies shall be provided upon the Fire Department's request.
3. The central station log shall be kept on a yearly basis and be maintained for six (6) years following the period of use.

## **PART 4. OUT-OF-SERVICE PROTOCOLS**

The owner or owner's representative shall be notified when any part of a fire alarm system is impaired. The Certificate of Fitness holder should attempt to correct the defect or impairment. If the defect or malfunction is not corrected at the conclusion of a system inspection, testing, or maintenance, the system owner or the owner's representative shall be informed of the impairment immediately. The Certificate of Fitness holder shall make a log book entry prior to notifying the owner. The owner also shall be notified when an impairment period is completed or discontinued. System defects and malfunction shall be corrected.

### **REQUIREMENTS FOR OUT-OF-SERVICE**

**901.7 Out-of-service systems.** See part 6 of this study material.

The Fire Code (FC) requires the Fire Department to be notified of any fire protection system (including fire alarm) outages. Below are the general information (non-emergency) numbers to use for the 5 boroughs.

Manhattan	(212) 570-4300
Brooklyn	(718) 965-8300
Queens	(718) 476-6200
Bronx	(718) 430-0200
Staten Island	(718) 494-4296

**901.7.1 Impairment coordinator.** The building owner shall assign an impairment coordinator to comply with the requirements of this section. In the absence of a specific designee, the owner shall be considered the impairment coordinator.

### **IMPAIRMENT SITUATIONS**

An S-97/S-98 Certificate of Fitness holder may discover an Out-of-Service fire alarm system (see "definitions") during his or her duties. This circumstance is referred to as an impairment situation. An S-97/S-98 Certificate of Fitness holder must notify the owner or the owner's representative of the FDNY requirements in this situation.

## Requirements

In any occupancy, where a required fire protection system (e.g. sprinkler system, fire alarm system and standpipe system) is out-of-service, a fire watch shall be maintained. The fire watch shall consist of one or more persons holding Certificates of Fitness for an F-01 (Fire Guard for Impairment). The fire guards are required to be immediately available when the system is out-of-service with the following exception:

When the affected area does not exceed 50,000 square feet, the impairment coordinator (or a trained and knowledgeable person who can perform fire watch duties and is designated by the building owner) may perform the duties of the fire watch for the initial 4 hours of a planned or unplanned out of service condition.

In other words, the impairment coordinator or a trained and knowledgeable person designated by the building owner should immediately begin conducting a fire watch in the area where the fire protection systems are out-of-service. After 4 hours of an out-of-service condition, such patrols shall only be conducted by fire guards holding the F-01 Certificate of Fitness.

The number of fire guards generally depends on the location and the size of the area affected by the out-of-service fire protection system. A fire guard should be available to patrol all areas in which the fire protection system is out-of-service at least once every hour. No individual fire guard should patrol more than 50,000 square feet of building floor area. It may be necessary that more than one fire guard be designated to meet this standard.

The recommended coverage for performing fire watch in affected area(s) is summarized in the table below.

Area	Planned or Unplanned < 4 hours	> 4 hours
≤ 50,000 ft <sup>2</sup>	A COF for F-01 City wide Fire Guard for an Impairment coordinator  An Impairment coordinator or a trained and knowledgeable person	One F-01 C of F holder
> 50,000 ft <sup>2</sup>	One F-01C of F holder per 50,000 square feet	

The fire guard should be maintained continuously, 24 hours a day, until such systems are restored to good working order. In some cases, Fire Department personnel may be on scene and can provide additional directions on the number of fire guards required and other fire protection measures until such time as the fire protection system is restored to good working order.

**The Certificate of Fitness holder must keep the Certificate of Fitness upon his or her person, or otherwise readily available for inspection by any representative of the Fire Department, at all times while conducting or supervising the material, operation or facility for which the certificate is required.**

Fire guards for impairment are recommended to be familiar with the types of fire safety evacuation plans for the buildings where they provide fire watches and the associated staff available to implement the fire plan. Fire guards must be familiar with his obligations for notifying the Fire Department in the event of fire. (FC901.7.7.)

### **Emergency procedures**

Fire guards must have a method of communicating to the emergency services. Fire guards can use cell phones to make immediate notifications. Fire guards should ensure that there is enough power to cover their shift. **Notifying by phone is the most direct and effective way to notify the Fire Department.**

### **Construction**

Temporary covering of fire protection devices to protect them during construction is permissible as long as the coverings are removed at the completion of each work shift.

## **PART 5. INSPECTION, TESTING AND OTHER MAINTENANCE**

**907.20 Inspection, testing and other maintenance.** Fire alarm and fire alarm detection systems shall be operated and maintained in accordance with Fire Code Section 901, the Fire Rules and NFPA 72.

### **INSPECTION**

Visual inspection shall be made to ensure that there are no changes that affect equipment performance.

**907.19 Instructions.** Inspection, testing, operation and maintenance instructions, as built design and installation documents and equipment shall be provided on site at an approved location.

### **TESTING**

**907.20.2 Testing.** Testing shall be performed in accordance with the schedules in NFPA 72 or more frequently, where required by the Fire Commissioner.

Where automatic testing is performed at least weekly by a remotely monitored fire alarm control unit specifically listed for the application, the system may be manually tested on an annual basis.

**Exception:** Devices or equipment that are inaccessible for safety considerations shall be tested during scheduled shutdowns where approved by the Fire Commissioner, but not less than every 18 months.

**907.20.3 Detector sensitivity.** Detector sensitivity shall be checked in compliance with the manufacturer's instructions and NFPA 72. Detectors which are connected to a fire alarm system that automatically transmit signals to the Fire Department or to a central station shall, as applicable, also be checked in compliance with the Fire Rules.

**907.20.4 Method.** To verify that each smoke detector is within its listed and marked sensitivity range, it shall be tested using one of the following methods or types of equipment, and detectors found to have a sensitivity outside the listed and marked sensitivity range shall be cleaned and recalibrated or replaced:

1. A calibrated test method.
2. The manufacturer's calibrated sensitivity test instrument.
3. Listed control equipment arranged for the purpose.
4. A smoke detector/control unit arrangement whereby the detector causes a signal at the control unit where its sensitivity is outside its acceptable sensitivity range; or
5. Another calibrated sensitivity test method acceptable to the commissioner.

**Exceptions:**

1. Detectors listed as field adjustable shall be allowed to be either adjusted within the listed and marked sensitivity range and cleaned and recalibrated or they shall be replaced.
2. This requirement shall not apply to single-station smoke alarms

**907.20.4.1 Testing device.** Detector sensitivity shall not be tested or measured using a device that administers an unmeasured concentration of smoke or other aerosol into the detector.

**904.4.2 Alarm testing.** Notification appliances, connections to fire alarm systems, and connections to an approved central station shall be tested in accordance with this section and Section 907 to verify proper operation.

**904.4.2.1 Audible and visible signals.** The audibility and visibility of notification appliances signaling agent discharge or system operation, where required, shall be verified.

**904.4.3 Monitor testing.** Connections to central stations shall be tested to verify proper identification and retransmission of alarms from fire extinguishing systems.

**MAINTENANCE**

**907.20.5 Maintenance.** The owner shall be responsible for ensuring that the fire and life safety systems are always maintained in good working order. Service personnel shall possess the qualifications set forth in NFPA 72 for inspecting, testing, servicing and otherwise maintaining such systems.

**907.20.5.1 Five-year retest.**

All fire alarm and other detection systems shall be retested once every five years from the date of acceptance of the system. The first retest of fire alarm and other detection systems lawfully existing on the effective date of this provision shall be conducted on or before the fifth anniversary of the date of acceptance after such effective date. Such test shall be conducted, and reported to the department, in the manner prescribed by rule, by a person holding a certificate of fitness for professional certification of fire alarm and emergency alarm installations and testing, as set forth in FC 104.2.1(1) and the rules, or a fire alarm system installer with NICET-Level II certification licensed by or registered with the State of New York and holding a certificate of fitness in accordance with the rules.

**907.20.6 Smoke detector maintenance.** The owner of any premises, or part thereof, monitored by a fire alarm system or sub-system thereof, whether required or not required by this code, which automatically transmit signals to the Fire Department or to a central station, shall be responsible for preventing unnecessary and unwarranted alarms as set forth in Fire Rules.

Cleaning and testing of smoke detectors shall be performed and records maintained of smoke detectors installed in a defined fire alarm system as required by the Fire Rules.

**907.20.7 Hold-open devices.**

The fire alarm system connections for hold-open devices installed on fire doors pursuant to the Building Code, including hold-open devices provided for vertical exit enclosure doors pursuant to the exception to Section BC 713.7 of the building Code, shall be inspected, tested and otherwise maintained in accordance with FC 703.2 and 907.20 and NFPA 72. Hold-open devices and automatic door closers provided for such vertical exit enclosure doors shall be inspected and tested annually to ensure the proper functioning of:

- 1.** the manual control on the fire alarm system control panel, or the fire command center where a fire command center is required, that transmits a signal to release the hold-open devices.
- 2.** the fire alarm system output programming, which automatically transmits a signal to release the hold-open devices upon activation of an automatic alarm initiating device or manual elevator recall.
- 3.** the circuitry for each hold-open device, which upon receipt of a manual or automatic signal, releases the door; and
- 4.** each automatic door closer, which, upon release of the door by the hold-open device, mechanically moves the door to its fully closed position.

## **PART 6. PARTIAL RELEVANT CODE SECTIONS**

### **6.1 Fire Code**

#### **6.1.1 Section FC 901 – General**

**901.1 Scope.** This chapter shall govern the design, installation, operation and maintenance, including inspection and testing, of fire protection devices, equipment and systems, and other fire protection measures for the control and extinguishment of fire.

**901.2 Design and installation documents.** The commissioner may require design and installation documents and calculations to be submitted for review for all fire protection systems. Design and installation documents required or regulated by this code or the rules shall be submitted for review and approval prior to installation and shall certify that the design complies with the requirements of this code and the rules.

#### **901.4 Design and installation.**

**901.4.1 Required fire protection systems.** Fire protection systems shall be designed and installed in accordance with the construction codes, including the Building Code, and, as applicable, this code and the rules, and the applicable referenced standards listed in this code. Required systems shall be extended or altered as necessary to maintain and continue protection whenever the building or structure is altered. Alterations to fire protection systems shall be performed in compliance with the requirements of this code, the rules, and the construction codes, as applicable. Buildings and structures shall be provided with such fire hose, portable fire extinguishers and other means of preventing and extinguishing fires as the commissioner may direct.

**901.4.2 Fire protection systems not required by code.** Any fire protection system or portion thereof not required by this code, the rules or the construction codes, including the Building Code, may be installed to provide partial or complete protection of a building or structure, provided such system meets the requirements of this code, the rules and the construction codes, including the Building Code, as applicable. Where the design and installation of such fire protection system is governed by this code or the rules, the commissioner may modify such requirements, consistent with the interests of fire safety, upon a determination that such modification will promote public safety by encouraging the installation of such systems.

**901.4.3 Additional fire protection systems.** Where the material or operation to be conducted in a particular occupancy gives rise to special hazards in addition to the normal hazards of the occupancy, or where the commissioner determines that access to the occupancy would unduly delay the ability of firefighting personnel to respond to the hazard, the commissioner may require additional safeguards. Such safeguards include, but shall not be limited to, the following: automatic fire detection systems, fire alarm systems, fire extinguishing systems, standpipe systems, or portable or fixed extinguishers. Fire protection equipment shall be installed in accordance with the construction codes, including the Building Code.

**901.4.4 Prohibition of deceptive equipment.** It shall be unlawful to install or maintain any device that has the physical appearance of fire protection equipment but that does not perform the fire protection function, in any building, structure or premises where it may be confused with actual fire protection equipment.

**901.4.5 Certificate of approval.** The following fire protection devices, equipment and systems shall be of a type for which a certificate of approval has been issued in accordance with this code, or which was approved by the Department of Buildings or the Board of Standards and Appeals prior to the effective date of this section, unless such approval by the Department of Buildings or the Board of Standards and Appeals is amended or repealed by the commissioner:

1. Pre-engineered non-water fire extinguishing systems, including systems installed in connection with commercial cooking systems.
2. Prefabricated hoods and grease filters installed in connection with commercial cooking systems.
3. Fire department siamese connections, standpipe system hose outlets and pressure reducing valves.
4. Fire alarm system control panels.

**901.5 Installation acceptance testing.** Fire detection and alarm systems, fire extinguishing systems, private fire hydrant systems, yard hydrant systems, standpipe systems, fire pump systems, private fire service mains and all other fire protection systems and appurtenances thereto shall be subject to acceptance tests as set forth in the installation standards specified in this code. Where required by the construction code, including the Building Code, this code or the rules, such tests shall be conducted, at the owner's risk, by his or her representative before a representative of the department. When an installation does not pass an acceptance test required to be witnessed by the department, the necessary corrections shall be made and the installation retested, or, when authorized by the rules, certification of such corrections by a licensed or certified professional submitted to the department

**901.5.1 Occupancy.** It shall be unlawful to occupy any portion of a building or structure until any required fire detection system, fire alarm system, standpipe system and fire extinguishing systems have been tested and approved.

**901.6 Maintenance.** Fire protection systems shall be maintained in good working order at all times. Any fire protection system that is not in good working order shall be repaired or replaced as necessary to restore such system to good working order, or, where authorized by the Building Code, removed from the premises.

**901.6.1 Standards.** Fire protection systems shall be inspected, tested, serviced and otherwise maintained in accordance with this section, the rules and the referenced standards listed in Table 901.6.1. Where required by this section, such inspection, testing and maintenance shall additionally comply with the rules. Where applicable, the requirements of the reference standards listed in Table 901.6.1 shall be in addition to those requirements specified in the rules.

**TABLE 901.6.1**

<b>FIRE PROTECTION SYSTEM MAINTENANCE STANDARDS SYSTEM</b>	<b>STANDARD</b>
Portable fire extinguishers	NFPA 10
Low, medium and high expansion foam systems	NFPA 11 and NFPA 25
Carbon dioxide fire extinguishing system	NFPA 12
Halon 1301 fire extinguishing systems	NFPA 12A
Foam water sprinkler and spray systems	NFPA 16 and NFPA 25
Dry chemical fire extinguishing systems	NFPA 17
Wet chemical fire extinguishing systems	NFPA 17A
Water based fire protection systems	NFPA 25
Fire alarm systems	NFPA 72
Water mist fire extinguishing systems	NFPA 750
Clean agent fire extinguishing systems	NFPA 2001
Aerosol fire extinguishing systems	NFPA 2010

**901.7 Out-of-service systems.** The owner and the impairment coordinator for a standpipe system, sprinkler system or fire alarm system shall comply with the requirements of this section whenever such fire protection system is out-of-service. The department may direct that, until such fire protection system has been returned to service, fire safety measures appropriate to the size, configuration, occupancy, use and hazards be implemented that are in addition to or in lieu of those required by this section.

**901.7.3 Planned removal from service.** The certificate of fitness holder and the impairment coordinator shall be made aware of and authorize the placing of systems out-of-service. Before authorizing such action the impairment coordinator shall:

1. notify the certificate of fitness holder responsible for supervising the maintenance of the standpipe system, sprinkler system or fire alarm system.
2. determine the extent and expected duration of the out-of-service condition.
3. inspect the areas or buildings involved and assess the increased risks.
4. make appropriate recommendations to the owner.
5. notify the department in accordance with FC901.7.5, if required.
6. notify the responsible person designated by the owner to issue hot work authorizations in accordance with FC Chapter 26.
7. notify the central station and insurance carrier.
8. notify the occupants in the affected areas if the duration of time the sprinkler system or fire alarm system will be out-of-service is estimated to be more than 30 minutes.
9. place a tag at each fire department connection, standpipe and sprinkler system control valve and fire command center, indicating which fire protection system, or part thereof, is out-of-service.
10. maintain the fire protection system in service until work is ready to begin.

**901.7.4 Unplanned out-of-service condition.** Any person, upon becoming aware of any condition, except a planned removal from service, rendering a standpipe

system, sprinkler system or fire alarm system, or part thereof, inoperable in whole or in part, shall notify the owner and the impairment coordinator of such condition. The impairment coordinator shall take the actions set forth in FC901.7.3 and 901.7.5, and such other actions as are necessary or appropriate to protect the occupants of the building and promptly restore the system to service.

**901.7.6 Restoring systems to service.** When an out-of-service device, equipment or system is restored to normal working order, the impairment coordinator shall:

1. Conduct necessary inspections and tests to verify that the affected systems are operational.
2. Notify the department.
3. Notify the owner, central station, insurance carrier and occupants in the affected areas.
4. Remove the out-of-service tags.

**901.8 Tampering with or rendering equipment inoperable.** Fire protection systems and related apparatus shall not be tampered with or rendered inoperable, except as set forth in Section 107.4.

**107.4.1 Temporary covering of fire protection devices.** Coverings placed on or over fire protection devices to protect them from damage during construction operations shall be removed immediately upon the completion of each work shift.

## **6.1.2 Section FC 907 – Fire Alarm & Detection Systems**

**907.1 General.** This section covers the operation and maintenance of fire alarm systems and their components.

**907.1.1 Design and installation documents.** Design and installation documents for fire alarm systems shall be submitted to the Fire Department for review and approval prior to system installation. Design and installation documents shall include such design and installation details as may be required by the construction codes, including the Building Code.

**907.2 Where required.** An approved manual, automatic, or manual and automatic fire alarm system shall be provided where required by the construction codes, including the Building Code or this code. An approved automatic fire detection system shall be installed in accordance with the construction codes, including the Building Code, and NFPA 72, as modified by FC Appendix B.

**907.4 Manual fire alarm boxes.** Manual fire alarm boxes shall be installed in accordance with the construction codes, including the Building Code.

**907.4.5 Protective covers.** The Fire Commissioner may require the installation of manual fire alarm box protective covers to prevent malicious false alarms or provide the manual fire alarm box with protection from physical damage. The protective cover shall comply with the requirements of the construction codes, including the Building Code.

**907.8 Presignal system.** Where a presignal system is installed, personal supervision shall be provided at an approved location, in order that the alarm signal can be activated in the event of fire or other emergency.

**907.13 Access.** Access shall be provided to each detector for periodic inspection, testing and other maintenance.

**907.14 Fire extinguishing systems.** Fire extinguishing systems shall be connected to the building fire alarm system where a fire alarm system is required or is otherwise installed.

**907.15 Monitoring.** Where required by this code, the Fire Rules or by the construction codes, including the Building Code, such monitoring by a central station shall be performed in compliance with the requirements of NFPA 72 and the Fire Rules.

**Exception:** Central station monitoring is not required for:

1. Single- and multiple-station smoke alarms required by Section 907.2.10 of the Building Code.
2. Smoke detectors in Group I-3 occupancies.
3. Sprinkler systems in Group R-3 occupancies.

**907.16 Automatic telephone-dialing devices.** Automatic telephone-dialing devices used to transmit an emergency alarm shall not be connected to any department telephone number unless approved by the Fire Commissioner.

**907.17 Acceptance tests.** Upon completion of the installation of a fire alarm system, including alarm notification appliances and circuits, alarm-initiating devices and circuits, supervisory signal initiating devices and circuits, signaling line circuits, and primary and secondary power supplies, such system shall be tested at the owner's risk, by his or her representative, before a representative of the Fire Department, to confirm its proper installation and operation of the system in compliance with the requirements of the Building Code and this code.

**907.18 Record of completion.** A record of completion in accordance with NFPA 72, as modified by FC Appendix B, this code and the rules, verifying that the system has been installed in accordance with the approved design and installation documents and specifications, shall be provided by the installing contractor.

**907.19 Instructions.** Inspection, testing, operation and maintenance instructions, as built design and installation documents and equipment specifications shall be provided on site at an approved location.

**907.20 Inspection, testing and other maintenance.** Fire alarm and fire alarm detection systems shall be operated and maintained in accordance with this code, Section 901, the Fire Rules and NFPA 72, as modified by FC Appendix B.

**907.20.2 Testing.** Testing shall be performed in accordance with the schedules in NFPA 72 as modified by FC Appendix B, or more frequently where required by the Fire Commissioner.

**Exception:** Devices or equipment that are inaccessible for safety considerations shall be tested during scheduled shutdowns where approved by the Fire Commissioner, but not less than every 18 months.

**907.20.3 Detector sensitivity.** Detector sensitivity shall be checked in compliance with the manufacturer's instructions and NFPA 72, as modified by FC Appendix B, and the rules. Detectors which are connected to a fire alarm system that automatically transmit signals to the Fire Department or to a central station shall, as applicable, also be checked in compliance with the Fire Rules.

### **907.20.4 Method.**

To verify that each smoke detector is within its listed and marked sensitivity range, it shall be tested using one of the following methods or types of equipment, and detectors found to have sensitivity outside the listed and marked sensitivity range shall be cleaned and recalibrated or replaced:

1. A calibrated test method;
2. The manufacturer's calibrated sensitivity test instrument;
3. Listed control equipment arranged for the purpose;
4. A smoke detector/control unit arrangement whereby the detector causes a signal at the control unit where its sensitivity is outside its acceptable sensitivity range; or
5. Another calibrated sensitivity test method acceptable to the commissioner.

### **Exceptions:**

1. Detectors listed as field adjustable shall be allowed to be either adjusted within the listed and marked sensitivity range and cleaned and recalibrated or they shall be replaced.
2. This requirement shall not apply to single-station smoke alarms.

**907.20.4.1 Testing device.** Detector sensitivity shall not be tested or measured using a device that administers an unmeasured concentration of smoke or other aerosol into the detector.

**907.20.5 Maintenance.** The owner shall maintain fire and life safety systems in good working order at all times. Service personnel shall possess the qualifications set forth in NFPA 72, as modified by FC Appendix B, and the rules, for inspecting, testing, servicing and otherwise maintaining such systems. When required by the rules, a smoke detector maintenance log book and an alarm log book shall be maintained.

**907.20.6 Smoke detector maintenance.** The owner of any premises, or part thereof, monitored by a fire alarm system or sub-system thereof, whether required or not required by this code, which automatically transmit signals to the Fire Department or to a central station, shall be responsible for preventing unnecessary and unwarranted alarms as set forth in Fire Rules. Cleaning and testing of smoke detectors shall be performed as set forth in the Fire Rules.

## **6.2 Fire Rules**

### **6.2.1 Section § 104-4 Certification of Corrected Defects in Fire Alarm System Installations**

- (a) Scope. This section sets forth the standards, requirements and procedures for certification of correction of defects in the design and installation of newly-installed and altered *fire alarm systems*, when such defective conditions are cited by the *Department* upon inspection or acceptance testing of such a system.
- (b) Definitions. The following terms, for purposes of this section and as used elsewhere in the *rules*, have the meanings shown herein:

Certification of corrected defects. Certification by licensed or certified professionals, in accordance with R104-04, that a defect cited by the *Department* in the design and/or installation of a *fire alarm system* has been corrected, as follows:

- (1) certification by the *fire alarm system* installer who personally corrected the defect. Such person shall either be:
    - (A) a principal of a company to which the *Department* has issued a company certificate for *fire alarm system* installation, inspection, testing and servicing who holds a *certificate of fitness* for *fire alarm system* installation, inspection, testing and servicing and for *certification of corrected defects*; or
    - (B) a technician employed by such a company who holds a *certificate of fitness* for *fire alarm system* installation, inspection, testing and servicing, and for *certification of corrected defects*; and
  - (2) if correction of the defect necessitated the installation of electrical wiring or other work requiring the services of a licensed electrician, certification by the licensed master electrician or licensed special electrician who holds a *certificate of fitness* for *certification of corrected defects* who personally corrected the defect or supervised the work of a qualified electrical technician under such licensed electrician's direction and control; and
  - (3) the licensed or certified professional who personally verified the functionality of the *fire alarm system* following correction of the defect. Such person shall hold a *certificate of fitness* for verification of corrected *fire alarm system* defects. Such person shall not be one of the licensed or certified professionals who certified correction of the *fire alarm system* defects.
  - (4) A licensed special electrician may certify correction of work or verify system functionality only for *fire alarm system* installations for which the special electrician made the required filings.
- (c) Applicability. In lieu of *Department* re-inspection, *owners* may elect to certify correction of defects in newly-installed or altered *fire alarm system* installations that have not yet been *approved* by the *Department*, when all of the following conditions have been met:
- (1) **Approved design documents.** The *owner* submitted *design and installation documents* with the *Department* and obtained *Department* approval of the design of the system;
    - a. **Acceptance test.** The owner's representatives conducted the required acceptance test of the system before *Department* representatives;
    - b. **System defects.** The *Department* identified defects in the design and installation of the system, including whether it operates as designed, as set forth in a notice of defect or other *Department* documentation issued after the effective date of this section, and such defects cited prior to the effective date of this section as the *Department* may

determine to allow to be certified pursuant to this section, consistent with the standards, requirements and procedures of this section;

- c. **Ineligible defects.** The notice of defect does not identify more than 10 fire alarm system defects in a low-rise building or more than 20 fire alarm system defects in a high-rise building, and/or does not identify any defects in the design and installation of any of the following system components (when required), including whether they operate as designed:

(A) Emergency *alarm systems*;

(B) Emergency power switchover;

(C) Firefighter service (Phase 1 and Phase 2), including elevator recall operation.

(D) Fan shut down affecting the operation of more than 20% of fan systems;

(E) Fire shutter operation;

(G) Power riser (including fire rating requirements);

(H) Primary power supply connection (including connection after building disconnect);

(I) Smoke control operation.

(J) Sprinkler water flow switches and other non-sprinkler fire extinguishing system activation devices;

(K) Stair pressurization; and

(L) Central station connection.

- (5) **Timely submission.** *Certification of corrected defects* is submitted to the *Department* within 90 days of the date the notice of defect was issued.

- (d) Eligibility for Certificate of Fitness for Certification of Corrected Defects. The following licensed or certified professionals may obtain a *certificate of fitness* for verification of corrected *fire alarm system* defects:

- (1) a *registered design professional*;

- (2) a principal of a company for which a company certificate for *fire alarm system* installation, inspection, testing and servicing has been issued, who is a fire alarm system installer registered with or licensed by the State of New York; and
  - (3) a master electrician or special electrician licensed by the *Department of Buildings*.
- (e) Scope of Certification of Professional Correcting Defects. *Certification of corrected defects* constitutes a representation by the licensed or certified professional correcting the defects, made under the authority granted to the licensed or certified professional by his or her professional license or certification and the applicable *Department* certificate, that the defect in the design or installation of the *fire alarm system*, identified in the applicable notice of defect, has been corrected, in accordance with the applicable requirements of the *Building Code*, *Fire Code*, *Electrical Code*, NFPA 72 and/or other law, rule, regulation, standard or component listing, as follows:
- (1) **Types of defects.** *Certification of corrected defects* constitutes a representation that each defect has been corrected as follows:
    - (A) **Missing component.** If the defect was a system component that was not installed, the component has been installed and connected to the requisite power source, and operates as designed.
    - (B) **Non-approved component.** If the defect was a system component that was not *listed* or otherwise not *approved* for use in New York City, the component has been replaced with a *listed* or *approved* component, and operates as designed.
    - (C) **Non-working component.** If the defect was a system component that was not working or not working properly, the condition has been corrected, and the component is in good working order and operates as designed.
  - (2) **Operates as designed.** For purposes of *certification of corrected defects*, “operates as designed” means that the system component performs the function for which it has been designed and installed, in accordance with the manufacturer’s specifications and the *approved design and installation documents* for the system, as amended by any as-built *design and installation documents* and (with respect to electrical work) any A-433 form, including activating or shutting down all devices the system component is designed to activate or shut down.
  - (3) **Minimum duration of testing.** *Certification of corrected defects* of a system component shall be based on operation of the device for the period of time necessary to assure its proper operation.
  - (4) **Inspection of other system components.** *Certification of corrected defects* includes a representation that other system components, within

the scope of work performed, have been inspected and tested, including inspection and testing of devices that activate such component and devices activated or shut down by the component. The certification does not include a representation that wiring and/or other inaccessible components have been inspected and tested, except for certifications by the licensed or certified professional who, to correct the defect, installed such wiring and/or performed work on such other inaccessible components.

- (f) **Scope of Certification of Professional Verifying System Functionality.** *Certification of corrected defects* constitutes a representation by the licensed or certified professional verifying the functionality of *fire alarm system* components after correction of defects, made under the authority granted to the licensed or certified professional by his or her professional license or certification and the applicable *Department* certificate, that a defect involving a missing or non-working component has been corrected and the *fire alarm system* components that were installed and/or repaired in order to correct the defective condition are operating as designed in accordance with the approved plans for the *fire alarm system*, as amended by any as-built *design and installation documents*, including the Input/Output programming matrix that defines the sequence of operation (as set forth in Section A.14.6.2.4 of Annex A to NFPA Standard 72).
- (g) **Submission and Acceptance of Certification of Corrected Defects.** *Certification of corrected defects* shall be submitted to the *Department*, and, if satisfactory, accepted by the *Department*, in the following manner:
- (1) **Submission.** *Certification of corrected defects* shall be submitted on the form *approved* by the *Department* for this purpose. If there are no defects in the design or installation of the *fire alarm system* and the notice of defect requires submission of the applicable A-433 form, as-built *design and installation documents* or other documentation required solely to complete the application (administrative defects), submission of *certification of corrected defects* is not required. Such submissions must bear such certifications as may be required by law, rule or *Department* procedure.
  - (2) **Required signatures.** The *approved* form for *certification of corrected defects* shall be personally signed by all parties required for the certification. As such, except as otherwise provided in R104-04(g)(3), it shall bear the signatures of up to three separate licensed or certified professionals: the signature of the one or two licensed or certified professional(s) who corrected the defect(s) and the signature of the licensed or certified professional who verified the functionality of the *fire alarm system* following correction of defects.

- (3) **As-built plans and A-433 forms.** To complete a *fire alarm system* application, any changes to a *fire alarm system* from the original approved design must be reflected on the applicable *Department A-433 form*, as-built *design and installation documents* and/or other required documentation and submitted
  
- (4) **Acceptance and letter of approval.** Upon acceptance of *certification of corrected defects*, including, where required, acceptance of the as-built *design and installation documents*, A-433 forms and/or other documentation, the *Department* will deem the defective condition corrected. If there are no other outstanding defects or other considerations preventing its issuance, a *letter of approval* will be issued for the *fire alarm system*.
  
- (h) **False Certification.** All *certifications of corrected defects* are subject to audit. Any licensed or certified professional and certificate holder found to have submitted false or fraudulent certification shall be subject to the penalties provided therefor in the Fire Code and rules, and any other applicable law, rule or regulation, including the penalties for misconduct set forth in R113-01(g) and R115-01(i), as applicable. False *certification of corrected defects* may also be considered in connection with the false certifier's fitness to hold other *certificates of fitness* or company certificates.

### **6.2.1 Section § 105-01 Approval of Fire Alarm System Installations**

- (a) Scope. This section sets forth the standards, requirements and procedures for the submission of *design and installation documents* for *fire alarm system* installations for *Department* review and approval.
  
- (b) General Provisions
  - (1) Submission and approval required. Pursuant to FC 907.3, *design and installation documents* for *fire alarm system* installations, containing such details as may be required by the Fire Code, *Building Code*, *Electrical Code* and this section, shall be submitted for *Department* review and approval prior to system installation in the form and manner prescribed on the *Department's* electronic portal.
  
  - (2) Certification of design and installation documents. Pursuant to FC 105.4.1, *design and installation documents* must be prepared by a *registered design professional*. Such documents shall bear the seal of such design professional, which shall serve to certify that the documents are in compliance with applicable provisions of the Fire Code, *Building Code*, *rules*, and other applicable laws, rules and regulations.

- (3) Filings upon completion of installation. Upon completion and satisfactory testing of a *fire alarm system* installation that comprises any part of a *core building system*, the *owner* shall submit a request for inspection pursuant to R105-01(c)(2). Upon completion of a *fire alarm system* installation that does not comprise any part of a *building core fire alarm system*, the *owner* may alternatively submit *professional certification* of the installation, except as may otherwise be provided in the letter of acceptance approving the design of the installation.
- (4) Format of design and installation documents. The *design and installation documents* required by this section shall be formatted (to scale) in the form and manner prescribed on the *Department's* electronic portal.

(c) Submission and Approval Procedure

- (1) Submission and approval of *design and installation documents*
  - (A) *Submissions. Applications for approval of fire alarm systems shall be electronically filed with the Department in the form and manner prescribed on the Department's electronic portal, including completion of the applicable application form and payment of applicable fees.*
  - (B) *Approval. The Department will review the design and installation documents submitted pursuant to R105-01(c)(1)(A), and, if determined to be in compliance with the requirements of the laws, rules and regulations enforced by the Department, approve such documents in accordance with FC 105.4.4.2 and Department procedures.*
- (2) Department inspection filing
  - (A) *Submissions. Applications for Department inspection of a fire alarm system installation shall include the following documentation and such other information and documentation as the Department may require:*
    - (1) the *Department's* “request for inspection” application form;
    - (2) “as built” *design and installation documents* of the *fire alarm system* installation, and the facility in which it is installed, as actually constructed, formatted in folio (11 x 17) size, and containing:
      - (a) the information required by *Building Code* Section 907.1; and

- (b) the Input/Output programming matrix and written certification required by R105-01(c)(2)(A)(3) and (4).

If such “as built” *design and installation documents* cannot be electronically filed at the time of submission of the request for inspection because installation work has not been completed, such “as built” documents may be submitted thereafter but no later than the date of inspection of the installation, either by electronically filing them using the *Department*’s electronic portal or by providing them to the *Department* representative at the time of inspection of the installation.

- (3) a completed Input/Output programming matrix that defines the sequence of operation, as set forth in Section A.14.6.2.4 of Annex A to NFPA Standard 72; and
- (4) a written statement from a *registered design professional*, a person holding a license to engage in the business of installing, servicing and maintaining fire alarm systems issued by the New York Secretary of State pursuant to Article 6-D of the New York State *Department of Buildings* and registered with the New York Secretary of State in accordance with such Article 6-D, certifying that a functional test has been conducted of the *fire alarm system* and the system operates as designed and in accordance with the Input/Output programming matrix. If such functional test cannot be conducted at the time of submission of the request for inspection because installation work has not been completed, such written certification may be submitted to the *Department* in accordance with R105-01(c)(2)(A)(2).

- (B) Acceptance. The *Department* will review such *application* for inspection and supporting documentation for completeness and/or other purposes, and if satisfactory, will authorize an inspection.

(3) Inspection and approval of fire alarm system installation

- (A) Availability of documents. A printed copy of standard-size (24” x 36”) set of approved engineering drawings of the *fire alarm system* design and installation, and a set of “as built” *design and installation documents* of the installation, pursuant to R105-01(c)(2)(A)(2), shall be made available for inspection by the *Department* representative at the time of inspection of the *fire alarm system* installation.

**6.2.2 Section § 907-01 Fire Alarm Recordkeeping, Smoke Detector Maintenance, Testing and Recordkeeping, and the Prevention of unnecessary and Unwarranted Fire Alarms.**

- a) Scope. This section sets forth standards, requirements and procedures for the operation and maintenance of *fire alarm systems* relating to fire alarm recordkeeping, *smoke detector* maintenance, testing and recordkeeping, and the prevention of *unnecessary* and *unwarranted alarms*.
- (b) General Provisions
- (1) Purpose. Pursuant to FC901.6, all *fire alarm systems* shall be maintained in good working order at all times. This section sets forth operating and maintenance requirements intended to minimize the number of *unwarranted* and *unnecessary alarms* transmitted by such systems that automatically transmit signals to the Fire Department or a *central station*, including minimum *smoke detector* maintenance and testing requirements, the type and format of alarm and maintenance records to be kept and used in identifying defective smoke detectors and patterns of *unnecessary or unwarranted alarm* transmissions. Such alarms, which trigger an emergency response, are costly and endanger the public safety. This section sets forth the standard to which the *owners* (including lessees) of *premises* having such systems shall be held in regard to the transmission of such alarms.
- (2) All *owners* shall comply with the requirements of this section and prevent *unnecessary* and *unwarranted alarms*.
- (c) Prevention of Unnecessary and Unwarranted Alarms
- (1) In any *premises* having a *fire alarm system* or a *smoke detector* that automatically transmits signals to the Fire Department or a *central station*, the *owner* (including any lessee) of the *premises* shall be responsible for preventing the transmission of *unnecessary* or *unwarranted alarms*, and shall be liable for any violation of this section.
- (2) It shall be unlawful to transmit two (2) or more *unnecessary* or *unwarranted alarms* in any three-month period, and it shall be unlawful to transmit any additional *unnecessary* or *unwarranted alarms* as set forth in R907-01(c)(4).
- (3) The *owner* of any *premises* from which a second *unnecessary* or *unwarranted alarm* is transmitted in any three-month period will be subject to issuance of a *notice of violation*. Such *notice of violation* will afford the *owner* the opportunity to address the cause of the *unnecessary* or *unwarranted alarm* and to certify correction of the violation in accordance with R109-01(c), without having to appear for an *ECB* hearing and without imposition of a penalty.
- (4) An *owner* issued a *notice of violation* pursuant to R907-01(c)(3) shall be liable for a violation of this section for any subsequent *unnecessary* or *unwarranted alarm* within six (6) months of the date of issuance of the *notice of violation*. Each such subsequent *notice of violation* shall constitute a repeat offense pursuant to *Administrative Code* §15-229(a) and shall not be eligible for certification of correction without a hearing and penalty pursuant to R109-

01(c). Each such subsequent *notice of violation* shall extend for an additional six (6) months the time the *owner* is liable for *unnecessary* or *unwarranted alarms* pursuant to this provision.

- (5) An owner issued one (1) or more *notices of violation* pursuant to R907-01(c)(3) or (4) who does not transmit any *unnecessary* or *unwarranted alarm* within six (6) months of the date of issuance of the last-issued *notice of violation* shall be restored to compliant status and shall thereafter be subject to issuance of a *notice of violation* only for two (2) *unnecessary* or *unwarranted alarms* within a three month period, as set forth in R109-01(c)(2).
- (6) Nothing contained herein shall be deemed to preclude the Fire Department from utilizing other means of enforcement with respect to *unnecessary* or *unwarranted alarms* that meet or exceed the number set forth in R907-01(c)(2).
- (7) For purposes of this section, the malicious transmission of a false alarm by activation of a *manual fire alarm box* shall not be construed as an *unnecessary alarm*.

(d) Alarm Log Book

- (1) The provisions of this section shall apply to any *premises* having a *defined fire alarm system*.
- (2) The fire safety director, or in buildings not requiring a fire safety director, a person designated by the *owner*, shall be responsible to make all log book entries required by this section.
- (3) An alarm log book shall be maintained on the *premises*, at the building's main fire alarm control panel. In the absence of a secure location at the main fire alarm control panel, the alarm log book may be secured during non-business hours in another area provided it is made available for inspection by any *Department* representatives responding to an alarm on the *premises*. Alarm log book entries shall be made in chronological order, recording the location and causes of all *alarm signals* transmitted by such *fire alarm system*.
- (4) The alarm log book shall be a bound book (other than spiral bound) with consecutively numbered and lined pages. The cover of the log book shall bear the inscription, "ALARM LOG BOOK", together with the name and address of the building. All entries shall be made in ink and dated. A separate log book shall be kept for each calendar year. Log books shall be retained for a period of three (3) years from the date of the last entry.
- (5) The alarm log book shall be divided into three (3) separate sections as set forth below. Each section shall have a sufficient number of pages to allow for entries for at least one (1) year. The following log book entries are required and shall be made in each instance:
  - (A) Daily entries. The name of the person who made the entry, the *certificate of fitness* number of the fire safety director on duty, if applicable, and the time each tour of duty began and ended, shall be entered in the alarm log book on a daily basis. These entries shall be set forth in columns in the log book as follows:
    - (1) name
    - (2) *certificate of fitness* number

- (3) time started
- (4) time relieved
- (B) System off-line entries. The date and time the alarm system was taken off-line, the reason for such action, the name and *certificate of fitness* number of the person notified at the *central station* (or other evidence of notification satisfactory to the Fire Department), and the date and time the system was restored to service, shall be entered in the alarm log book in each such circumstance. These entries shall be set forth in columns in the log book as follows:
  - (1) time off line
  - (2) reason off line
  - (3) *central station* name and telephone number
  - (4) time restored
- (C) Activated alarm entries. The date and time the alarm activated, the type and location of the device (e.g., *smoke detector*, 27th floor, elevator lobby), the probable cause of the alarm, and the Fire Department unit and officer responding shall be entered in the alarm log book in each such circumstance. These entries shall be set forth in columns in the log book as follows:
  - (1) date and time activated
  - (2) location and detector type
  - (3) probable cause
  - (4) *Department* unit and officer
- (D) Notification entries. The date and time of any notification to the occupants of the *premises* pursuant to FC Chapter 9 and R907-01(d), regarding a non-functioning or improperly functioning alarm system.
- (e) Smoke Detector Maintenance and Recordkeeping
  - (1) Owner responsibility. The *owner* (including any lessee) of any *premises* monitored by a *defined fire alarm system* shall be responsible for the detector maintenance required by FC Chapter 9 and the *smoke detector* cleaning and testing required by this section.
  - (2) Certificate of fitness. The *smoke detector* cleaning and testing required by this section shall be performed by a person holding a *certificate of fitness* for *smoke detector* maintenance.
  - (3) Smoke detector maintenance company certificate. Such work shall be performed under the supervision of a company holding a *smoke detector maintenance company certificate*. All other *smoke detector* maintenance and testing shall be performed by a person possessing the requisite qualifications and experience, and any applicable license or certificate. Notwithstanding the foregoing, the *smoke detector* cleaning and testing required by this section may be performed by an *owner* of the *premises*, or an employee thereof, who possesses a *certificate of fitness* for *smoke detector* maintenance and the tools, instruments or other equipment necessary to perform *smoke detector* cleaning and testing required by this section.
  - (4) Smoke detector cleaning and testing

- (A) All *smoke detectors* connected to a *defined fire alarm system* shall be cleaned and tested in compliance with the procedures set forth in the manufacturer's specifications and in NFPA 72, except that where such procedures are inconsistent with the provisions of this section, the provisions of this section shall apply.
  - (B) All *smoke detectors* connected to a *defined fire alarm system* shall be:
    - (1) cleaned not less than once every six (6) months, except for analog (intelligent) *smoke detectors*, which shall be cleaned no later than one (1) week from receipt of an indication of the need for cleaning.
    - (2) tested for smoke entry not less than once a year.
    - (3) tested for sensitivity not less than once a year, except for analog (intelligent) *smoke detectors*, which shall be tested for sensitivity no later than one (1) week from receipt of an indication of the need for such testing.
  - (C) Any *smoke detector* not performing in conformance with the manufacturer's specifications or the standards set forth in NFPA 72 shall be re-calibrated, repaired or replaced, as required, in accordance with the manufacturer's recommendations and the requirements of said standard.
- (5) Smoke detector maintenance recordkeeping
- (A) The provisions of this section shall apply to any *premises* having a *defined fire alarm system*.
  - (B) A *smoke detector* maintenance log book shall be maintained on the *premises* in the office of the fire safety director, or, in buildings not requiring a fire safety director, in the building superintendent's office. Such log book shall state the total number of *smoke detectors* on the *premises* and list each *smoke detector* by location. Entries shall be made in such log book, in chronological order, regarding the installation, repair, maintenance and testing of the *smoke detectors*, and any signals transmitted by such detectors. Such entries shall include the date and the person and company performing such work, and any signal transmitted by analog (intelligent) *smoke detectors* communicating a need for cleaning and/or adjustment.
  - (C) The fire safety director, or in buildings not requiring a fire safety director, a person designated by the *owner*, shall be responsible to make all *smoke detector* maintenance log book entries required by this section.
  - (D) The *smoke detector* maintenance log book shall be a bound book (other than spiral bound) with consecutively numbered and lined pages. The cover of the log book shall bear the inscription, "SMOKE DETECTOR MAINTENANCE LOG BOOK," together with the name and address of the building or occupancy. All entries shall be made in ink and dated. A separate log book shall be kept for each calendar year. Log books shall be retained for a period of three (3) years from the date of the last entry. A computer record that is designed to prevent or detect alteration of information and that is otherwise maintained in a manner acceptable to the Fire Department, may be maintained in lieu of a bound log book provided that such computerized

record is available on the *premises* for inspection by any *Department* representative during business hours.

- (E) A copy of the *smoke detector* manufacturer's recommended maintenance procedures shall be kept with the *smoke detector* maintenance log book.
- (F) Compliance with Other Laws, Rules and Regulations. Nothing contained in this section shall be construed to authorize any installation, alteration or repair of electrical wiring or other component of a *fire alarm system* that any other law or rule, including the *Electrical Code* or the *Building Code*, requires to be performed by a licensed electrician.

### 6.3 Fire Department Information Bulletins (Fire Alarm Inspection Unit)

<https://www.nyc.gov/site/fdny/codes/reference/bulletins.page>

#### 2020

- [#02-09/2020 Revision 1 - Filing procedures for requesting expedited FA Plan Examination Unit Reviews](#)
- [#01-09/2020 Filing procedures for "Core and Shell" Installations](#)
- [#12-01/2013 Secondary Fire Command Center Guidelines \(revised\)](#)

#### 2019

- [#03-01/2019 Locations of Fire Command Centers](#)

#### 2012

- [#08-02-12 Mounting Height for Fire Alarm Equipment](#)
- [#01-03-12 Modification of Fire Alarm Signaling](#)

### 6.4 NFPA 72-2016 National Fire Alarm Code

The relevant sections of NFPA 72 (2016) will be provided to applicants that are testing at the Fire Department. However, it is critical that you read and understand NFPA 72 (2016) before taking the test.

### 6.5 NYC 2025 Electrical Code

#### 6.5.1 EC SECTION 780.33

**760.33 Fire Alarm Circuit and Equipment Grounding.** Fire alarm system and equipment grounding shall be installed in accordance with the following:

**(A) Grounding Electrode Conductor.** Each service or separately derived system supplying a fire alarm system shall be provided with a separate grounding electrode conductor originating at any point on the building grounding electrode system and sized and installed in accordance with Part III of Article 250.

**(B) Equipment Grounding Conductor.** Where there are conduits supplying 120V to the fire command center, control unit, or distributed control cabinets, a separate green

insulated equipment grounding conductor shall be sized and installed in accordance with Article 250, Table 250.122.

**(C) Grounding Separately Derived Supply.** A green insulated equipment grounding conductor shall be sized and installed in accordance with Article 250, Table 250.122, using a minimum of 10 AWG, in distributed cabinets where the 120V supply is not derived from the main fire alarm power supply. In steel framed buildings, an additional connection to local steel shall be permitted.

### **6.5.1 EC SECTION 760.41**

**760.41 NPLFA Circuit Power Source Requirements.** The power source for fire alarm circuits shall comply with (A) through (E).

**(A) Primary Power Source.** All fire alarm circuits shall be provided with a primary power source not exceeding 600 volts nominal supplied by utility company power or isolated plant. The primary power supply to the fire alarm system shall comply with the following:

**(1) Primary Power Supply for the Fire Alarm System(s).** Where a fire alarm system is installed as required by the New York City Building Code, primary power supply shall be connected to the primary power source ahead of all building service disconnecting means so that the building service disconnecting means can be opened without de-energizing the fire alarm supply.

**(2) Primary Power Supply for Dedicated Function Fire Alarm System.** Primary power supply for Dedicated Function Fire Alarm System shall be permitted to be connected to the power supply through the protected area of such system by means of a connection ahead of the disconnecting means for the power supply to the protected area.

**(3) Primary Power Supply for Releasing Fire Alarm System(s).** Where the building is not equipped with an automatic or manual fire alarm system power riser, primary power supply for Releasing Fire Alarm System shall be permitted to be connected to the power supply through the protected area of such system by means of a connection ahead of the disconnecting means for the power supply to the protected area.

**(4) For Nonrequired (Voluntary) Fire Alarm Systems Primary Power Supply.** Primary power supply for nonrequired (voluntary) fire alarm system shall be permitted to be connected to the power supply through the protected area of such system by means of a connection ahead of the disconnecting means for the power supply to the protected area. Informational Note: Dedicated Function Fire Alarm System (required and voluntary) and Releasing Fire Alarm System may also use the connected means defined in paragraph (1) where available.

**(B) Secondary Power Source.** Where an emergency power system is provided or required to be provided for emergency system loads, the fire alarm circuits shall be connected to the emergency power system. The secondary power supply shall be

connected such that all other disconnecting means serving other building emergency loads can be opened without de-energizing the facility fire alarm secondary power supply.

All building fire alarm systems connected to an emergency generator shall be provided with a dedicated transfer switch and be connected ahead of the emergency generator overcurrent protective devices as follows:

(1) 208Y/120 volts systems-by a dedicated fused disconnecting means.

(2) 480Y/277 volts systems-by a dedicated fused disconnecting means on the secondary of the associated transformer.

**(C) Battery.** Regardless of whether a secondary power source is also provided, each fire alarm system shall be equipped with a storage battery power supply sized to meet the operating power requirements of the system in accordance with (1), (2) or (3) below and shall automatically connect to and operate the fire alarm system upon failure of the primary or secondary power supply or sources.

**(1) With Voice Communications Capability.** Supervisory operation for 24 hours followed by full load operation for 6 hours for systems with voice communications capability. Informational Note: A 45-minute period of voice and alarm operation at the maximum connected load shall be considered equivalent to 6 hours of total system operation.

**(2) Without Voice Communications Capability.** Supervisory operation for 24 hours followed by full load operation for 15 minutes for systems without voice communications capability.

**(3) Dedicated Function Fire Alarm System (DFS) and Releasing Fire Alarm System (RFAS).** Supervisory operation for 24 hours followed by full load operation for 15 minutes.

**(D) Arrangement of Power Sources.** 1 source of power shall be connected to the fire alarm system at all times. The primary and secondary power sources shall be arranged and controlled by an automatic transfer switch dedicated to the fire alarm system such that the secondary source will be automatically connected to the fire alarm system should the primary power source fail. The following conditions shall be met where applicable:

(1) Intermediary devices between the fire alarm system power supply and the power source, other than fused disconnect switches, transformers and automatic transfer switches are prohibited. Such disconnect switches, transformers, and automatic transfer switches shall supply only the fire alarm system and other systems specifically permitted by applicable New York City rules and regulations.

(2) The primary and secondary power sources shall each be provided with a means of disconnecting from the fire alarm system. Each disconnecting means shall consist of a fused disconnect switch, locked in the ON position. The key shall be kept on premises and made accessible only to authorized personnel. Such disconnect shall be painted red and permanently identified as a fire alarm circuit and labeled as to system/location served.

(3) The fire alarm system fused disconnect switch on the transformer secondary side shall comply with the requirements of the primary and secondary power source fused disconnect switches pursuant to Article 240.

(4) For buildings served at up to 300 volts to ground, the service voltage shall be transformed to 208/120 volts and a fire alarm fused disconnect, provided within a circuit length of 10 feet (3 m), shall be connected at the transformer secondary on the 208/120-volt side.

(5) Approved disconnecting means assembly, such as fusible panel boards with compact branch fused disconnects or fusible switches, with selectively coordinated overcurrent protection device shall be provided where multiple circuits are required to support the fire alarm system and related auxiliaries.

**(E) Branch Circuit.** An individual branch circuit shall be required for the supply of the power source. The location of the branch circuit overcurrent protective device shall be permanently identified. The circuit disconnecting means shall have red identification, shall be accessible only to qualified personnel, shall not contain any splices, and shall be identified as "FIRE ALARM CIRCUIT". This branch circuit shall not be supplied through ground-fault circuit interrupters or arc-fault circuit interrupters. Where splicing is necessary, a listed method utilizing irreversible mechanical wire termination shall be permitted. The fire alarm branch-circuit disconnecting means shall be permitted to be secured in the ON position.

### **6.5.2 EC SECTION 760.49**

**(A) Sizes and Use.** Only copper conductors' size 14 AWG and larger shall be permitted to be used as NPLFA circuit conductors.

**(B) Insulation.** Insulation on conductors shall be suitable for 600 volts, 90 C, and shall comply with Article 310. Conductors shall be Type THHN, THWN/THHN, TFFN, TFN, FEP, RHH, RHW2, XHH, XHHW, MI, or listed electrical protective systems. Application of conductor ampacity shall be in accordance with 110.14 for terminal device ratings.

**(C) Conductor Materials.** Conductors shall be solid copper up to size 10 AWG. Stranded copper conductors shall be used for sizes 8 AWG and larger.

### 6.5.3 EC SECTION 760.131

**760.131PLFA Mechanical Execution of Work.** Installation shall conform to the following requirements:

**(A) Mechanical Rooms, Elevator Rooms, Garages and Loading Docks.** All wiring installed up to 8 ft (2.4 m) above the finished floor in garages, loading docks, mechanical rooms, and elevator rooms shall meet the installation requirements of Article 344. Wiring installed above 8 ft (2.4 m) above finished floor shall meet the installation requirement of Articles 342, 344, and 358, or use Type MI Cable in accordance with Article 332. Where flexibility is required after installation, Flexible Metallic Conduit (FMC) or Liquid tight Flexible Metallic Conduit (LFMC) shall be permitted up to 36 inches (915 mm) at the last termination.

**Exception:** For mechanical rooms and elevator rooms having a floor area of less than 900 square feet (83.6 square meters), installation pursuant to Articles 332, 342, 344, or 358 is permitted without height limitation.

**(B) Releasing Fire Alarm Systems.** Suppression systems activated by automatic fire detection and using fire alarm cables shall be installed pursuant to Articles 332, 342, 344, or 358. Such systems shall include, but not be limited to, pre-action sprinkler, deluge sprinkler, water mist, clean air agent, Halon, range hood, CO<sub>2</sub>, and dry chemicals."

**(C) Installation.** Installation of raceways, boxes, enclosures, cabinets, and wiring shall conform to the following requirements:

- (1) Covers of boxes, enclosures, and cabinets shall be painted red and permanently identified as to use.
- (2) Penetrations through rated walls, ceilings, and floors shall be fire stopped.
- (3) Raceways or wiring shall not penetrate the top of any control equipment cabinet or enclosure.
- (4) Raceways shall not be installed in stair enclosures unless they are serving the stairways. Informational Note: For allowed raceways that are serving stairs enclosures, refer to Section 1023.5 of the New York City Building Code.
- (5) Cables shall be secured by cable ties, straps, or similar fittings designed and installed so as not to damage cables. Such fittings shall be secured in place at intervals not exceeding 5 ft (1.5 m) in the center and within 1 ft (300 mm) of associated cabinet, enclosure, or box.

## 6.7 Unit Measurement and Formulas

**(This material will be provided to candidates as reference material for use during the test)**

### Ohm's Law

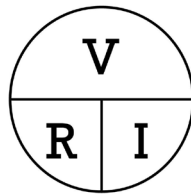

$$V = I \times R$$

$$R = V/I$$

$$I = V/R$$

### Parallel Circuit

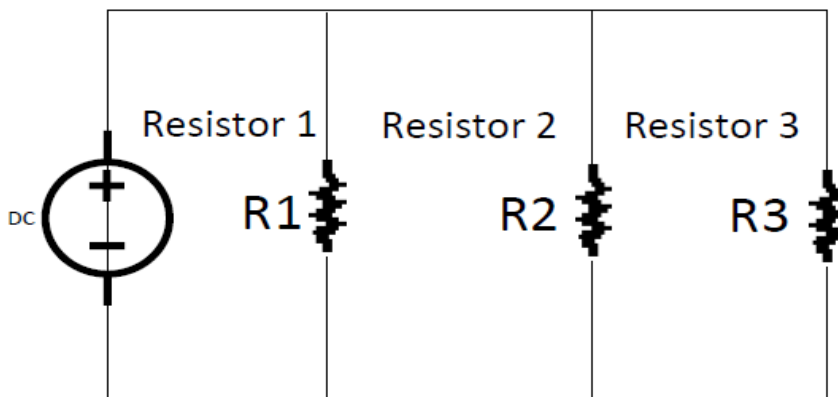

$$\frac{1}{R_{eq}} = \frac{1}{R1} + \frac{1}{R2} + \frac{1}{R3}$$

### Series

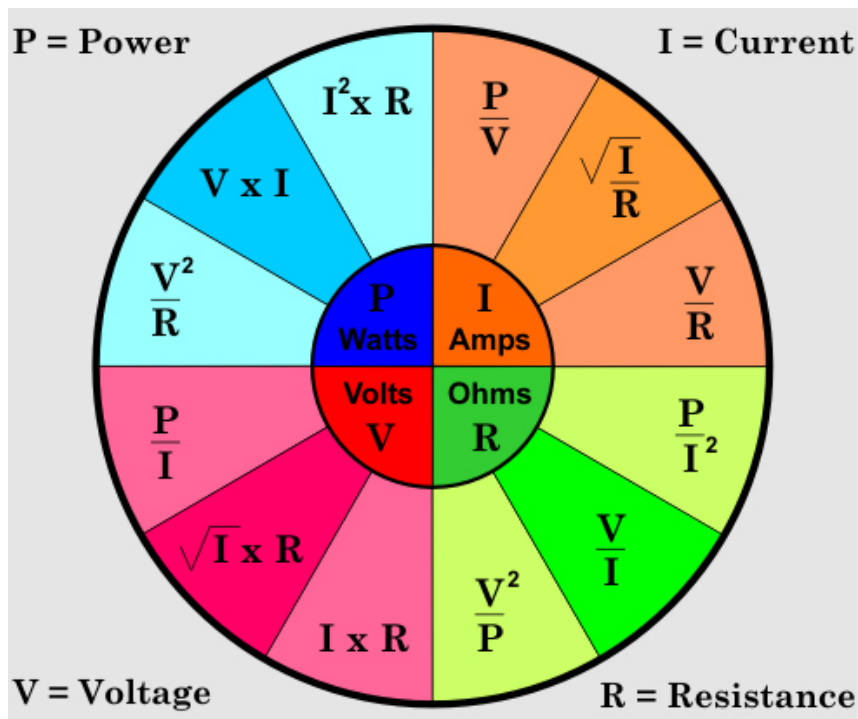
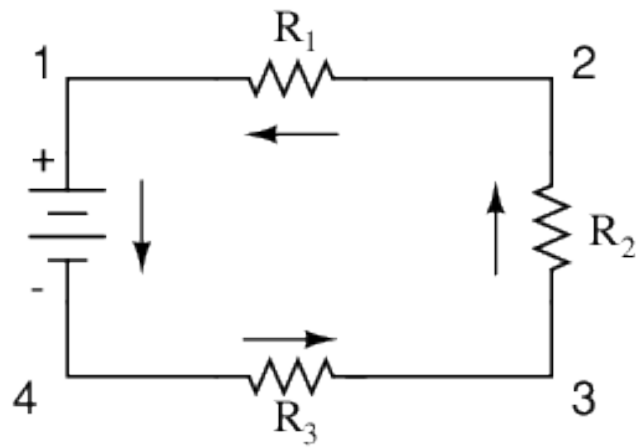

### Calculation for Standard Smoke Detectors:

**For Single Smoke Detector: 30ft x 30 ft = 900 sq ft= 1 Detector**

### 6.8 Resistor Color Code.

(This material will be provided to candidates as reference material for use during the test)

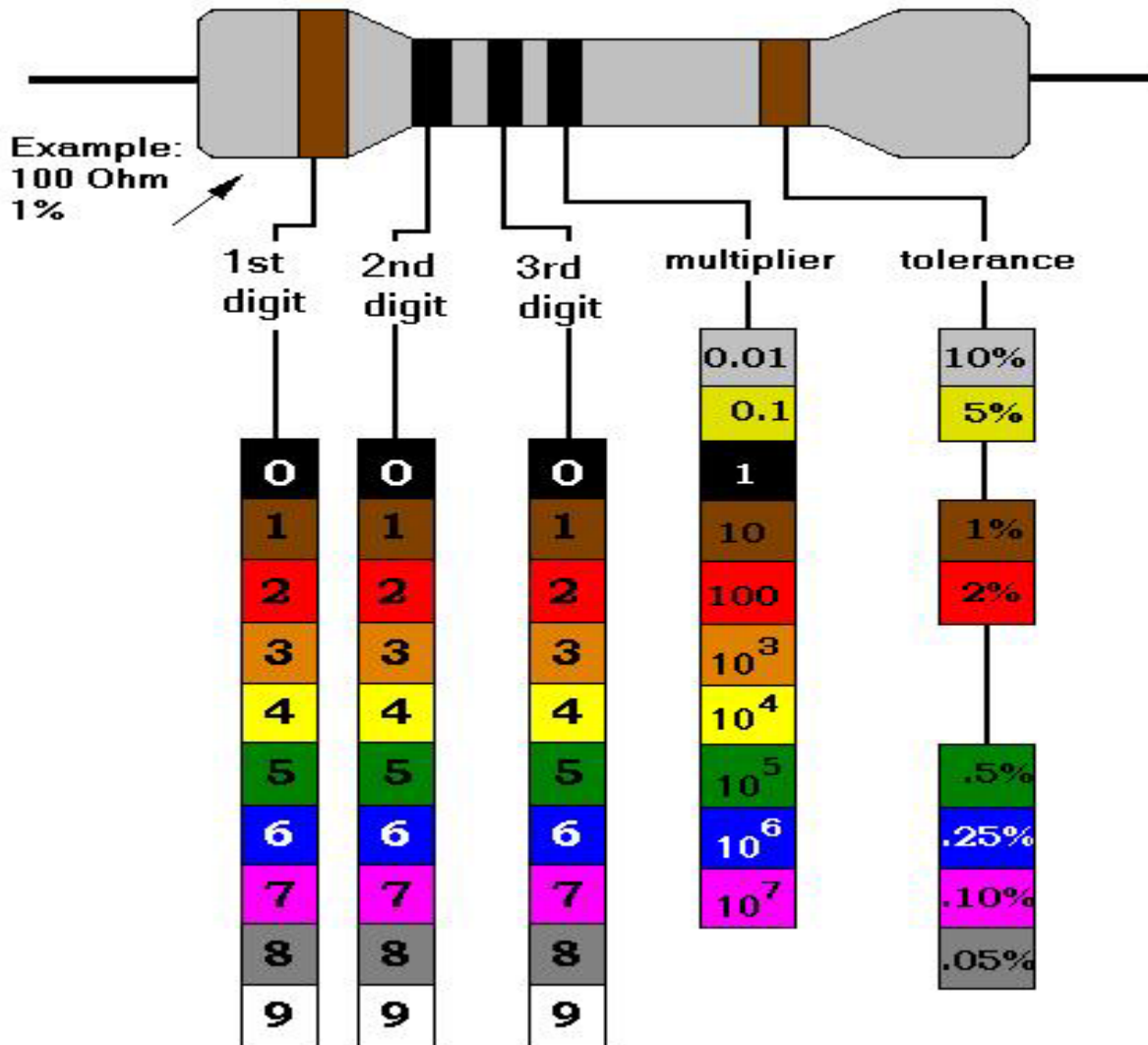

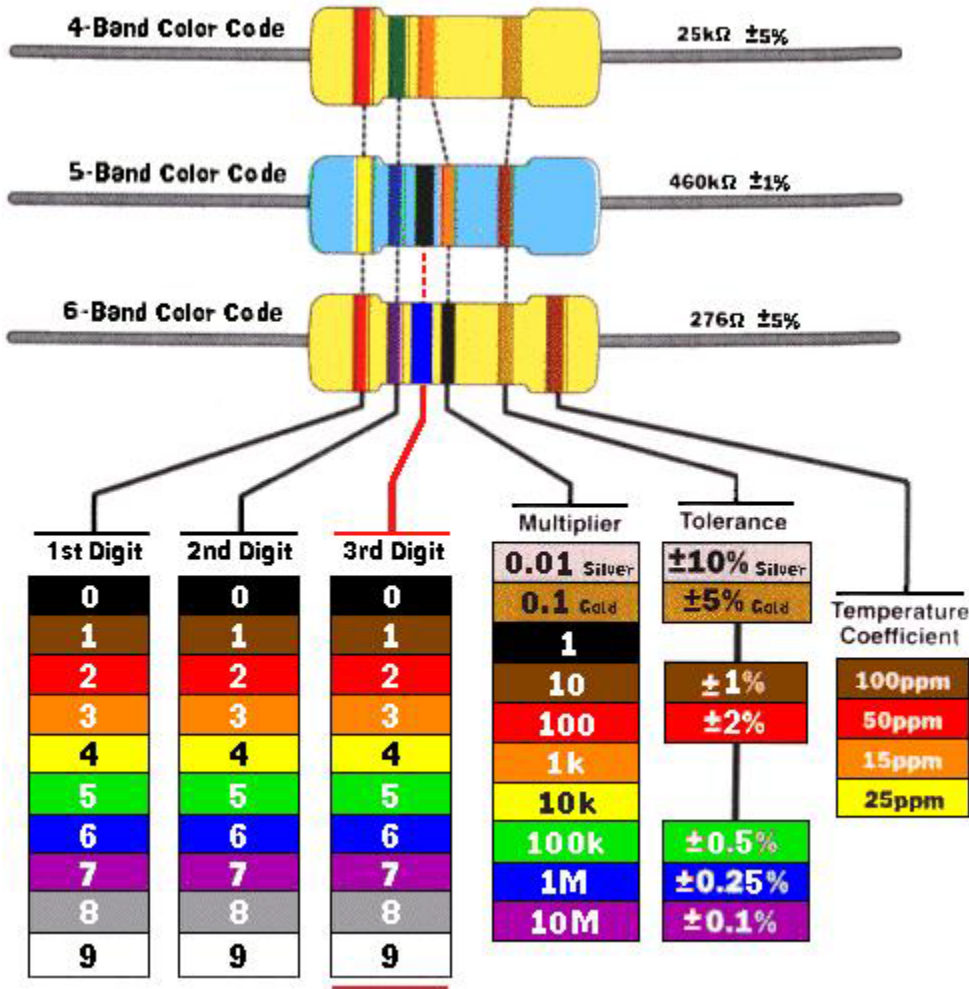

## Temperature Classification and Color Code for Heat-Sensing Fire Detectors

<u>Temperature classification</u>	<u>Temperature Rating Range</u>		<u>Maximum Ceiling Temperature</u>		<u>Color Code</u>
	<u>*F</u>	<u>*C</u>	<u>*F</u>	<u>*C</u>	
Low*	100 - 134	39 - 57	80	28	uncolored
Ordinary	135 - 174	58 - 79	115	47	uncolored
Intermediate	175 - 249	80 - 121	155	69	White
High	250 - 324	122 - 162	230	111	Blue
Extra high	325 - 399	163 - 204	305	152	Red
Very extra high	400 - 499	205 - 259	380	194	Green
Ultra-high	500 - 575	260 - 302	480	249	Orange

\*Intended only for installation in controlled ambient areas. Units shall be marked to indicate maximum ambient installation temperature.

### 6.9 Common Defects for Installation, Testing and Servicing Fire Alarm Systems

#### Failure to meet the following requirements:

- Provide 8-hour battery backup for central station phone line modem.
- Provide for waterflow alarm activation to be between 30-90 sec.
- Provide for smoke detector to be installed at least 36 inches away from any air diffuser.
- Complete the installation of door release.
- Arrange for remote LED to have mechanical protection (back boxes).
- Provide for conduit to be ¼ inch off wall as per damp locations electrical code.
- Arrange for fire shutters to have safety pads as per manufactures specifications.
- Provide/Arrange for elevator to recall upon activation of elevator lobby smoke detector elevator lobby.
- Provide for AC unit to shut down upon activation of any automatic alarm and make operable as per code.
- Provide/Arrange for CO producing equipment to shut down upon activation associated CO detectors. (Note: Gas fired boiler and AC units)

- Provide/Arrange for central station to receive separate and distinct signals for alarm, trouble and supervisory signals.

## **PART 7. LITHIUM-ION BATTERY SAFETY**

### **Lithium-ion safety**

Lithium-ion batteries are rechargeable batteries found in electric bikes, scooters, cars, laptops, tablets, phones, and many other common household devices.

Lithium-ion battery fires have caused deaths, serious injuries, and devastating damage to property around the city. It's important to follow rules for safe storage, charging, and disposal for these types of batteries.

If you own a lithium-ion powered device or plan to buy one, the FDNY has important safety tips that you should follow. These tips apply to all devices powered by lithium-ion batteries, including phones, tablets, laptops, e-cigarettes, toys, high-tech luggage, and even robotic vacuum cleaners.

**Immediately stop** using or charging battery and call 911 if you notice:

- **Fire or smoke**
- **Overheating**
- **Change in color or shape**
- **Odd noises**
- **Leaking**
- **Strange smell**

### **ALWAYS:**

- purchase and use devices certified by a Nationally Recognized Testing Laboratory (NRTL). 
- follow the manufacturer's instructions for:
  - charging and storage.
  - correct battery, cord, and power adapter
- **keep exit path clear at all times.**
- plug directly into a wall electrical outlet for charging.
- keep batteries and devices at room temperature.
- store and/or charge batteries away from anything flammable.
- keep away from heat sources.

### **NEVER:**

- use aftermarket batteries or chargers.
- use damaged or altered batteries
- plug into a power strip or overload an outlet.
- overcharge or leave battery charging overnight.
- charge a battery or device under your pillow, on your bed, or near a couch.
- leave e-bikes or e-scooters unattended while charging.
- block your primary way in or out of a room/space with e-bikes, e-scooters, wheelchairs, etc.
- place batteries in Trash or Recycling bin. **It is ILLEGAL.** Visit

- bring batteries to the NYC **Battery Recycling Center**. Visit [nyc.gov/batteries](https://nyc.gov/batteries) for more information. [nyc.gov/batteries](https://nyc.gov/batteries) for disposal locations and information.

**In the event of a Fire,**

**Leave and CLOSE the door.**

**Call 911 once you are in a safe location.**



### **Charging Lithium Ion**

Lithium-ion batteries do not have to be fully charged; partial charge is the most suitable.

When **charging more than five (5)** personal mobility devices or their removable batteries, it must be in a **dedicated room with ventilation** and a self-closing door.

For a total battery capacity of 20 kilowatt-hours (kWh), a 2-foot separation between charging batteries is required. For a total battery capacity up to 50 kWh, a 3-foot separation is needed.

Chargers must only be used with a compatible battery pack. The original equipment manufacturer (OEM) charger interplays with the battery pack using the battery management system (BMS). The wrong battery/charger combination may not work safely. For example, the 100% cutoff to prevent overcharging, which damages batteries, may not work, which can easily create hazardous conditions such as fires, explosions and/or injuries.

Always check with the manufacturer or retailer of the personal mobility device, an authorized repair shop or a testing laboratory such as Underwrites Laboratories (UL) to see if replacement is recommended or listed and safe for use with that device. Using unauthorized parts, including batteries and/or chargers, may cause damage, fire and possibly void your warranty.

### **Extinguishing Lithium-ion**

Water may not prevent a battery from burning and spreading. Battery cells are known to explode and quickly spread to another battery. It can spread to another devices.



**Fire Extinguishers**  
**do not work**  
on lithium-ion batteries fires.

### **Unexpected Re-ignition.**

Reignition is common. Lithium-Ion Batteries are known to unexpectedly re-ignite (without warning) minutes, hours and even days after all visible fire has been put out.

Lithium-ion batteries can enter an uncontrollable, self-heating state. This can result in the release of gas, cause fire and possible explosion.

These batteries may continue to generate heat even when there is no visible sign of fire. Once heat reaches a certain level fire may reignite on the battery and surrounding area.

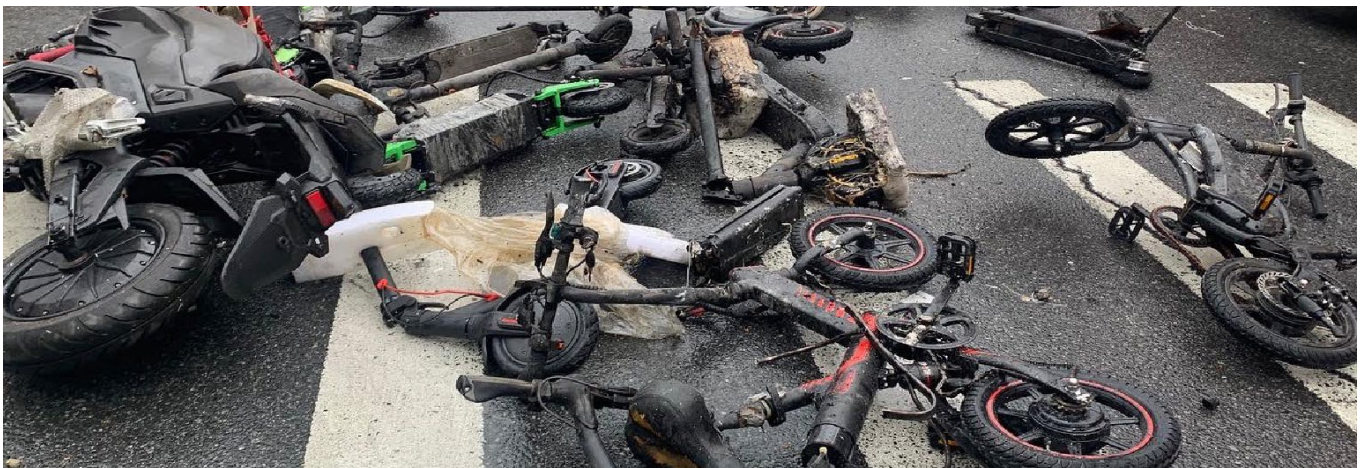

## **NEW S-98 - LIST OF MAJOR CHANGES**

THE FOLLOWING INFORMATION IS TAKEN OUT OF THE NEW S-98 CERTIFICATE OF FITNESS STUDY MATERIAL. BELOW IS A LIST OF MAJOR CHANGES.

S-98 Study Material and Exam were switched from:

2010 NFPA 72 Standard to 2016 NFPA 72 Standard

2014 NYC Fire Code to 2022 NYC Fire Code

2011 NYC Electrical Code to 2025 Electrical Code

Added Common List of Defects

NEW DEFINITIONS:

ACCESSIBILITY

ARCS (Auxiliary Radio Communications System)

DEDICATED FUNCTION FIRE ALARM SYSTEM (DFS):

DEFINED FIRE ALARM SYSTEM

FIRE ALARM CONTROL UNIT (FACP, FCS)

SMOKE DETECTOR

RELEASING FIRE ALARM SYSTEM (RFAS):

UNWARRANTED ALARM