



LANDLORD INSTRUCTIONS ABATING LEAD PAINT HAZARDS

New York City Department of Health & Mental Hygiene (DOHMH)
Healthy Homes Program (HHP)

1

You have been served with a New York City Department of Health and Mental Hygiene (DOHMH) Commissioner's Order to Abate Nuisance. You are ordered to correct lead paint violations in a dwelling, which you own or manage, within **5 days** of receipt of the Order. The Healthy Homes Program identified these violations during an inspection.

LANDLORDS MUST:

Hire an EPA-Certified Lead Abatement Firm (contractor) to correct lead paint violations.

- Abatement firm, supervisor and workers must be certified by US Environmental Protection Agency (EPA).
- Refer to: Handout [2](#) "Landlord Instructions, Hiring EPA-Certified Lead Abatement Firms and Lead Inspectors".

File a Notification of Commencement of Lead Abatement (yellow form).

- Fill out notification form completely and sign.
- Fax or hand-deliver to the Healthy Homes Program (HHP) 1-3 days before work begins. **The Healthy Homes Program is located at 125 Worth Street, 6th floor, New York, NY 10013. The fax number is (347) 396-8926.**
- Re-file notification if you change contractor, start date, or work methods.
- You must also file a notification with the Environmental Protection Agency (EPA). Please call EPA Region 2 at (732) 321-6671 for more information.

Use Safety Standards in the New York City Health Code §173.14. The Health Code Safety Standards describe all procedures, including, but not limited to:

- Posting warning signs
- Cleaning and removing furniture or cleaning and covering with plastic sheeting.
- Covering floors, windows, and air vents with 2 layers of plastic sheeting.
- Sealing work area with plastic sheeting and covering the door with 2 layers of plastic sheeting.
- Adjusting all painted doors and windows so that painted surfaces do not bind.
- Fully preparing work area before starting abatement work.
- Using only approved lead abatement methods.
- Preventing workers from tracking paint dust and debris from work area.
- Doing daily and final cleaning using wet methods and HEPA vacuuming.
- **For full details refer to New York City Health Code §173.14.**
- Also refer to Handout [4](#) "Methods for Abating Lead Paint Hazards" for more information.

Hire an EPA-Certified Lead Inspector to take clearance dust wipes when the work is completed.

- EPA-Certified Inspector or Risk Assessor, independent of the abatement contractor, must take dust samples.
- Results must be faxed or hand delivered to HHP within 5 days after work is finished.

- **Call 646-632-6002 for more information** about complying with the Commissioner's Order or if you wish to contest the violations. To contest the Order, you must contact the Healthy Homes Program within 3 days of receipt of the Order.
- **Failure to comply fully with Commissioner's Order to Abate** can result in fines of up to \$2,000 per violation.
- **A tenant CANNOT be evicted for lead paint violations.**
- **Federal law requires that landlords notify** tenants and prospective buyers about any known lead paint or lead paint hazards in the apartment or house.
- **For information on J-51 tax abatement or tax exemption** call the Department of Housing Preservation and Development (HPD) at 311.

LANDLORD INSTRUCTIONS: Hiring EPA-Certified Lead Abatement Firms & lead INSPECTORS

New York City Department of Health & Mental Hygiene (DOHMH)
Healthy Homes Program (HHP)

You have been served with a New York City DOHMH Commissioner's Order to Abate Nuisance. You must correct all lead paint hazards cited in the order.

You must:

- Hire an EPA-Certified Lead Abatement Firm to correct the lead paint violations.
- Hire an EPA-Certified Lead Inspector (Lead Paint Evaluation Firm) to make a final inspection and take dust wipe samples when the work is finished. The inspector must be independent of the abatement contractor and the owner.

What does EPA-Certified mean?

- EPA-Certified lead abatement supervisors, workers and lead inspectors have completed a training program approved by the US Environmental Protection Agency (EPA).
- **Lead abatement firms** have workers who have been trained in lead abatement methods, safe work practices, cleaning methods and worker protection. EPA-Certified supervisors have completed a 32-hour course and certified workers have completed a 16-hour course. EPA requires that all lead abatement jobs have at least one EPA-certified lead abatement supervisor assigned to the project.
- **Lead inspectors** are trained to inspect for lead paint hazards and to take dust wipe samples after the lead abatement work is finished. EPA-Certified inspectors have completed a 24-hour course. **Lead risk assessors** are inspectors who have additional training.

How do I find an EPA-Certified Lead Abatement Firm and an EPA-Certified Lead Inspector?

- Call EPA at 732-321-6671 for lead abatement firms and lead evaluation firms in NYC or visit EPA's website at <http://cfpub.epa.gov/flpp/>
- Look in the phone book for environmental services or lead paint detection services.
- HHP does not endorse any specific lead abatement firm, inspector, or listing service.

What should I ask before hiring a lead abatement contractor?

- Most importantly, ask if the contractor is certified by the EPA.
- Ask if the contractor uses the lead abatement and cleaning methods in the NYC Health Code §173.14.
- Ask the contractor for a work plan that describes: how each violation will be corrected, how the contractor will prepare the work area and seal off the rest of the apartment, how the work area will be cleaned.
- Ask how long the work will take.
- Tell the contractor that an EPA-Certified supervisor and EPA-Certified workers must do the work.
- Ask how the contractor will prevent lead dust and debris from spreading out of the work area.
- Ask if the contractor has ever had any violations for unsafe lead abatement work.
- Ask the contractor for references from other building owners who had similar work done. Call the references and ask if they were satisfied with the contractor, and if the work was completed on time.

What questions should I ask before hiring a lead inspector to take dust wipes?

- Ask if the inspector is independent of the abatement company and the building owner?
- Ask if the inspector uses a laboratory approved by New York State to analyze dust samples. Ask for the Environmental Laboratory Approval Program (ELAP) number.
- Ask if the inspector uses a laboratory accredited by the National Lead Laboratory Accreditation Program (NLLAP). Ask for the American Industrial Hygiene Association (AIHA) or the American Association of Laboratory Accreditation (A2LA) certificate number.

For more information call the New York City Department of Health and Mental Hygiene, Healthy Homes Program (HHP) at: 646-632-6002.



INSTRUCTIONS
ABATEMENT SUPERVISORS & INSPECTORS
New York City Department of Health & Mental Hygiene (DOHMH)
Healthy Homes Program (HHP)

3

PLEASE FORWARD TO THE LEAD ABATEMENT FIRM AND LEAD INSPECTOR.

NOTICE TO LEAD ABATEMENT FIRM

Read this notice carefully. If you have been hired to correct lead paint violations in the home of a lead poisoned child, you must follow all rules in the NYC Health Code §173.14.

You must be an EPA-Certified lead abatement firm and you must:

- Provide your company name, contact person, phone and fax numbers, and address to the building owner before starting the job.
- Complete and sign the Notification of Commencement of Lead Abatement (yellow form).
- Require that all workers assigned to the job be EPA-Certified.
 - Supervisor and workers must have their EPA Lead Abatement Certificates at the jobsite.
 - Supervisor and workers must show certificates to a health department inspector upon request.

Provide a scope of work to the building owner for all lead hazard repairs:

- Describe all surfaces and components to be abated as cited in the Commissioner’s Order.
- Describe the method of abatement for each surface or building component.
- Provide a start and finish date for the repairs.

You must follow the rules in New York City Health Code §173.14. The rules include, but are not limited to:

- Posting warning signs.
- Cleaning and removing furniture or cleaning and covering with plastic sheeting.
- Covering floor, windows, and air vents with 2 layers of plastic sheeting.
- Sealing work area with plastic sheeting and covering the door with 2 layers of plastic sheeting.
- Adjusting all painted doors and windows so that painted surfaces do not bind.
- Fully preparing work area before starting abatement work.
- Using only approved lead abatement methods.
- Preventing workers from tracking paint dust and debris from work area.
- Doing daily and final cleaning using wet methods and HEPA vacuuming.
- **For full details refer to New York City Health Code §173.14**
- Also see Handout [4](#) “Methods for Abating Lead Paint Hazards” for more information.

NOTICE TO LEAD INSPECTORS

If you have been hired to take dust wipe samples when the work is finished, you must:

- Not be an employee of the building owner or the abatement contractor.
- Provide your company name, contact person, phone and fax numbers, address and EPA Certificate Number to the building owner before the job starts.
- Submit dust wipe samples for analysis to a laboratory accredited by the EPA National Lead Laboratory Accreditation Program (NLLAP) **and** approved by the NYS Environmental Laboratory Approval Program (ELAP).
- Complete and sign the Notification of Commencement of Lead Abatement (yellow form).

NOTICE: Working without proper EPA-Certification or failure to follow safety standards can result in fines up to \$2000 per violation to the contractor and the building owner.
For more information call the Healthy Homes at: 646-632-6002.

LANDLORDS AND CONTRACTORS: The New York City Health Code requires specific abatement methods and work procedures for correcting lead paint violations in housing where a lead poisoned child lives or visits frequently. Examples of some lead abatement methods approved under the NYC Health Code Safety Standards are described below. Use this information to select and apply appropriate abatement methods.

Below are some acceptable abatement methods for certain building components. Refer to New York City Health Code §173.14 for a description of all acceptable methods.

Please note: Dry sanding and scraping lead paint is prohibited.

Component	Walls and Ceilings	Windows	Doors and Door Frames	Baseboards, Moldings and Trim	Radiators, Cabinets, and Other Surfaces
Acceptable Methods	Enclosure	Enclosure <i>(Sills, Aprons, Casings only)</i>	Enclosure <i>(Door Frames Only)</i>	Enclosure	Enclosure
		Replacement	Replacement	Replacement	Replacement
		Paint Removal	Paint Removal	Paint Removal	Paint Removal

During all lead paint abatement work, you must use New York City Health Code Safety Standards described in Section 173.14. Safety standards include: preparing the work area, containing dust and debris, and daily and final cleanup. If you fail to follow these safety standards you are subject to fines.



FIX BUILDING PROBLEMS BEFORE YOU BEGIN

As part of the abatement, you **must** repair any conditions that may cause paint to peel, crack, blister, or chip. Common building problems that damage paint include: water leaks from pipes, roofs, windows, or radiators. Any repair or maintenance work that disturbs paint must be done safely to prevent release of paint dust and debris.

Explanation of Wall Numbers

In the Commissioner’s Order to Abate Nuisance, walls and building parts are identified by numbers. The wall with the doorway or entrance is Wall #1. Starting at the entrance and facing into the room, the walls are numbered in a clockwise direction as shown in the diagram below. If there is more than one doorway or entrance, one doorway will be designated as the reference point.

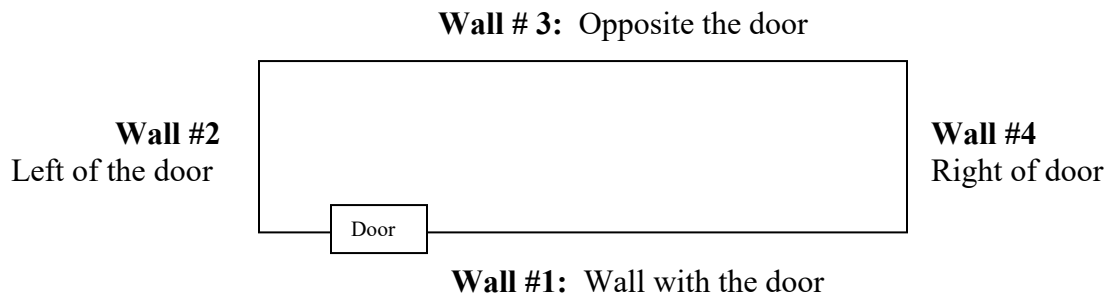

Instructions: Abating Lead Paint Hazards

ENCLOSURE

Enclosure is the installation of a rigid barrier onto a lead painted surface.

To enclose a lead painted surface, follow these instructions:

1. Make sure the structure to be enclosed is sound and can hold the weight of the enclosure.
2. Dampen loose or defective paint with a water mister.
3. Use a scraper to remove defective paint while it is damp.
4. Before covering walls, remove baseboards.
5. Cover walls entirely with wallboard, sheet rock, plasterboard, or paneling.
6. Tightly seal all seams after enclosure and replace baseboards with lead free components.
7. Paint new component (where appropriate) with primer and two coats of non-lead based paint.

Notice:

- Currently, the Lead Program allows use of liquid encapsulants by approval only.

REPLACEMENT

This method is strongly recommended for windows and doors.

To remove and replace lead painted components, follow these instructions:

1. Wet mist or HEPA-vacuum old component before removal.
2. Remove entire component using appropriate methods to minimize dust dispersal.
3. Wrap old building part in plastic sheeting and dispose of properly.
4. Install new part. Seal properly to avoid leaving spaces or holes around edges.
5. Paint new component as necessary with primer and two coats of non-lead based paint.

PAINT REMOVAL

This method preserves historic or decorative building parts, but is *not* recommended in most other cases.

To remove lead paint, follow these directions:

1. Select a paint removal method: off-site paint removal or on-site; chemical stripping; using a heat gun below 1100°F; or power sanding with HEPA dust collector. **Please note: Dry scraping and dry sanding lead paint is prohibited.**
2. Clean up debris and dust as you work.
3. Seal surfaces with a primer and two coats of non-lead based paint or other coating material.

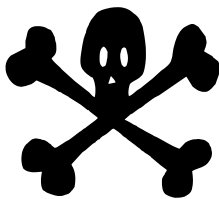

PROHIBITED METHODS OF PAINT REMOVAL

- Dry scraping and sanding
- Chemical strippers containing methylene chloride
- Grinding or sanding without HEPA exhaust
- Heat guns operating above 1100°F
- Open flame gas fired torch

NOTICE: AREAS DAMAGED DURING ABATEMENT

All surfaces near the work area damaged during abatement must be repaired and returned to an intact condition and repainted using safe methods and precautions.

Building Structure Diagrams

WALLS

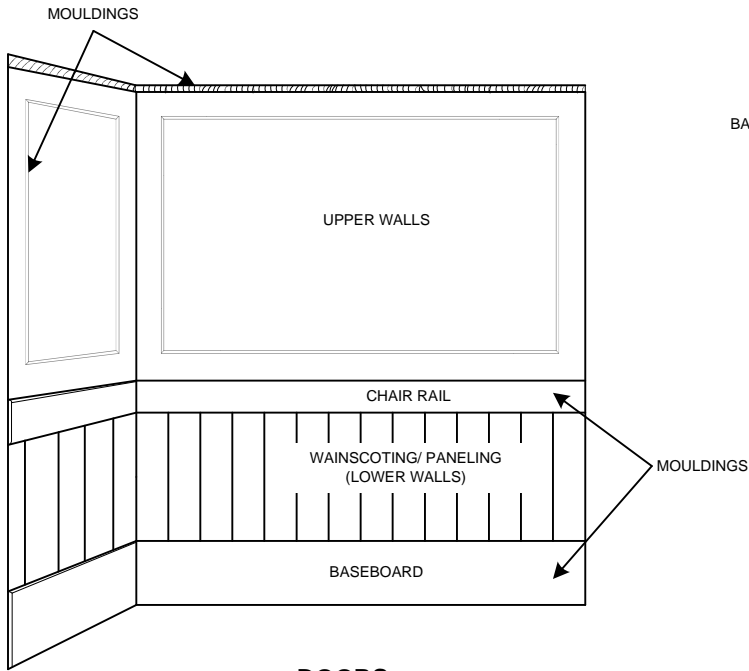

STAIRS

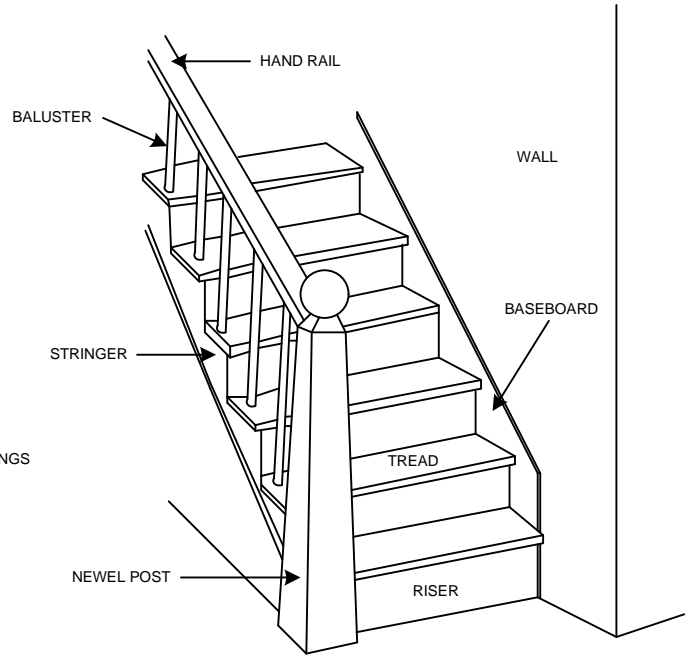

DOORS

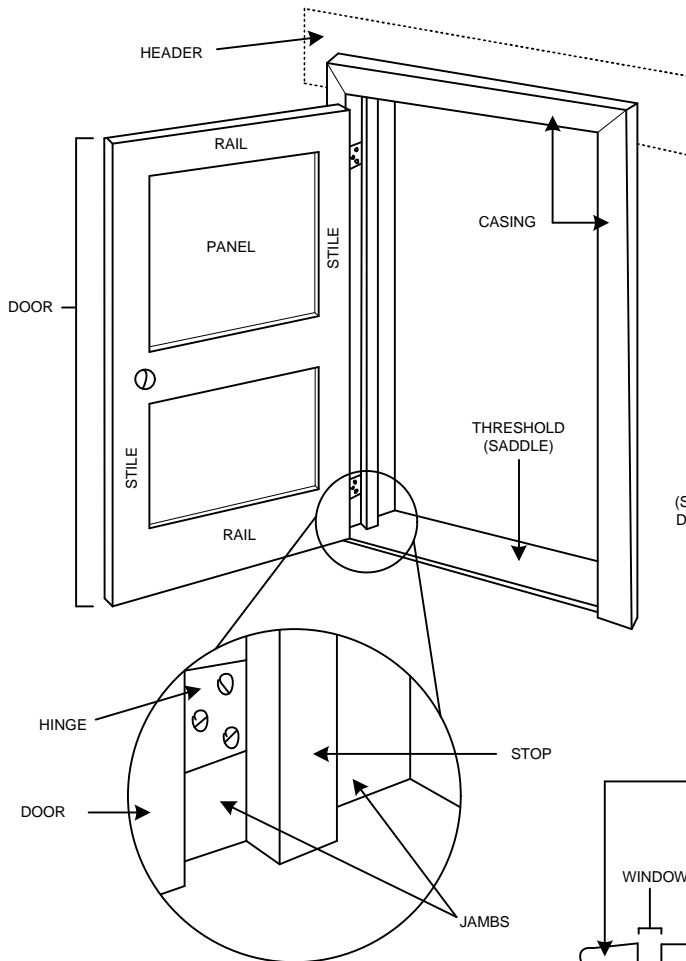

WINDOWS

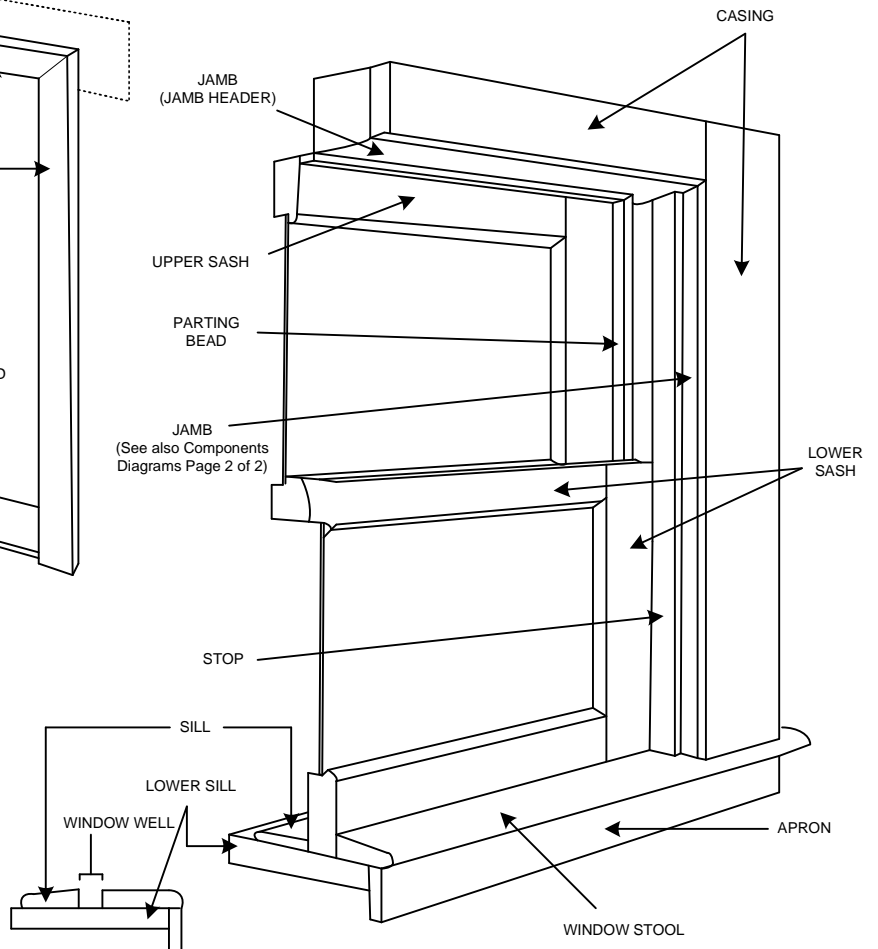

***Some components described in the diagrams may not be present in structures at the property.**

WINDOW JAMB VARIATIONS DIAGRAMS

Unless otherwise noted in the Commissioner's Order, a jamb violation includes:

- Side and header jambs (exposed jambs on both the interior and exterior parts of a window).
- Jamb tracks.
- Stops and window well.
- All decorative mouldings covering jambs.

EXPOSED JAMB

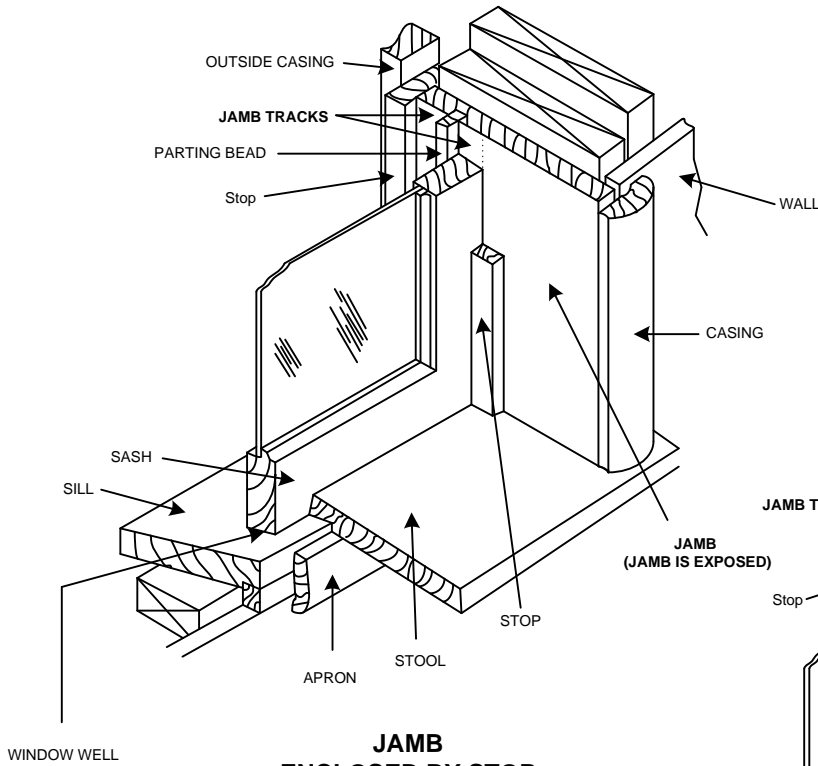

JAMB WITH DECORATIVE MOULDING

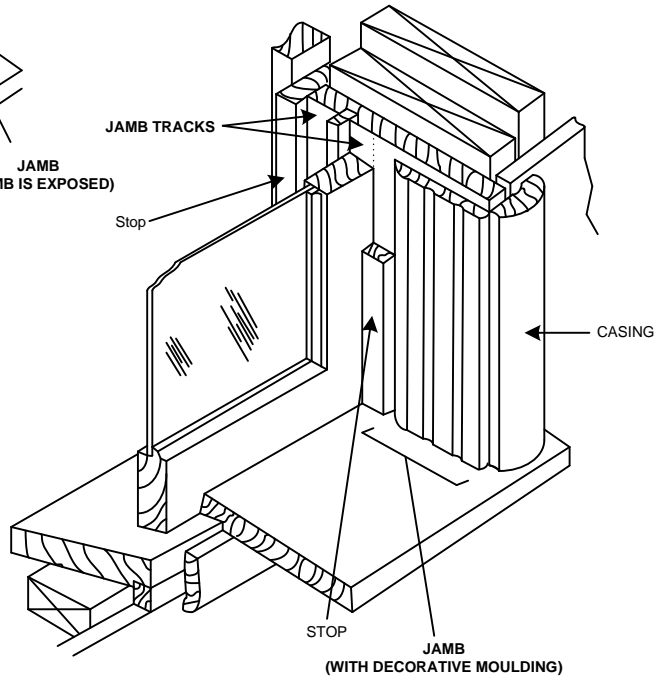

JAMB ENCLOSED BY STOP

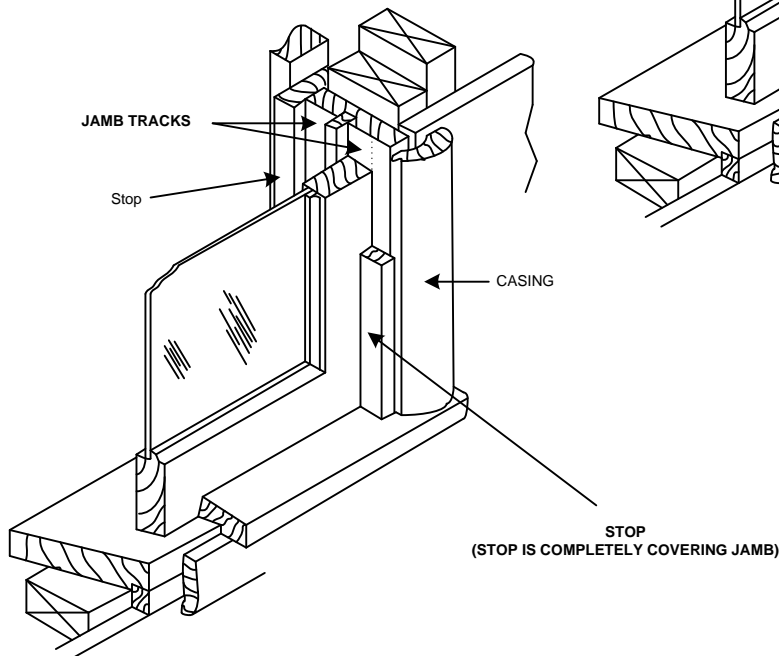

NOTIFICATION OF COMMENCEMENT OF LEAD ABATEMENT/REMEDATION

NOTIFICACIÓN DE COMIENZO DE TRABAJO PARA EL CONTROL DE PLOMO

DATE: _____ DOHMH Order No.: _____ CHILD ID: _____
(FECHA) (NO. DE ORDEN DE DOHMH) (NO. DE IDENTIFICACION DEL NIÑO)

Post Copies of This Notice at least 24 Hours Before Starting Work
CALL (646) 632-6002 TO MAKE ANY COMPLAINTS CONCERNING THIS WORK

IF YOU HAVE RECEIVED A COMMISSIONER'S ORDER TO ABATE OR REMEDIATE YOU MUST COMPLETE AND FILE THIS NOTICE. THEN, HAND DELIVER OR FAX THIS NOTICE NO LESS THAN 24 HOURS AND NO MORE THAN 96 HOURS BEFORE BEGINNING THE REPAIR WORK ORDERED BY THE DEPARTMENT OF HEALTH AND MENTAL HYGIENE (DOHMH). FILE A COMPLETED COPY OF THIS FORM WITH:

THE NEW YORK CITY DEPARTMENT OF HEALTH AND MENTAL HYGIENE
FIELD SUPPORT UNIT

125 WORTH STREET, 6TH FLOOR, CN 58 NEW YORK, NEW YORK 10013
Telephone Number: (646) 632-6002 Fax Number: (347) 396-8926

NOTE: File any changes in the information provided in this notice with the Department of Health and Mental Hygiene before beginning work, or if work has begun, within 24 hours of any change.

Copias de Esta Notificación Deben Ser Colocadas en un lugar visible, por lo menos 24 horas antes de empezar el trabajo.
ALGUNA QUEJA SOBRE ESTE ASUNTO PUEDE SER DIRIGIDA LAS 24 HORAS AL DIA, AL SIGUIENTE TELÉFONO: (212) 676-6379

EL DUEÑO DE LA PROPIEDAD DEBE LLENAR ESTE FORMULARIO Y NOTIFICARNOS EN NO MENOS DE 24 HORAS Y NO MAS DE 96 HORAS EN PERSONA O VIA FAX ANTES DE COMENZAR EL TRABAJO ORDENADO POR EL DEPARTAMENTO DE SALUD Y SALUD MENTAL (DOHMH). DIRIJA DICHA NOTIFICACIÓN A LA SIGUIENTE DIRECCIÓN:

THE NEW YORK CITY DEPARTMENT OF HEALTH AND MENTAL HYGIENE
FIELD SUPPORT UNIT
125 WORTH STREET, 6TH FLOOR, CN 58 NEW YORK, NEW YORK 10013
 Número de teléfono: (646) 632-6002 Número de fax: (347) 396-8926

NOTA: Si tiene algún cambio que hacerle a la información proporcionada en este formulario, debe informar al Departamento de Salud y Salud Mental antes de comenzar el trabajo, o si el trabajo ya comenzó, tiene 24 horas para informar al Departamento después que el cambio haya ocurrido.

PLEASE PRINT OR TYPE CLEARLY (POR FAVOR ESCRIBA EN IMPRENTA O ESCRÍBALO A MÁQUINA)

LOCATION OF LEAD BASED PAINT VIOLATION(S) (INFORMACIÓN SOBRE LA UBICACIÓN DE LAS VIOLACIONES)

ADDRESS: <small>DIRECCIÓN:</small>	APT: <small>APTO:</small>	BOROUGH: <small>CONDADO:</small>	ZIP CODE: <small>ZONAL POSTAL:</small>
--	-------------------------------------	--	--

OWNER INFORMATION (INFORMACIÓN SOBRE EL DUEÑO)

NAME (NOMBRE):	PHONE (TEL): ()	FAX: ()
ADDRESS (DIRECCIÓN):	CITY (CIUDAD):	STATE (ESTADO):
ZIP (ZONAL POSTAL):	SIGNATURE (FIRMA):	<small>(MUST BE SIGNED)(DEBE DE SER FIRMADO)</small>

EPA CONTRACTOR (FIRM) INFORMATION (INFORMACIÓN SOBRE EL CONTRATISTA)

Co. NAME (NOMBRE DE LA COMPAÑIA):	CONTACT PERSON (PERSONA A CONTACTAR):
ADDRESS (DIRECCIÓN):	CITY (CIUDAD): STATE (ESTADO):
ZIP (ZONA POSTAL):	PHONE (TEL): () FAX: ()
SIGNATURE (FIRMA):	EPA CERTIFICATE No.:

DUST TESTING COMPANY / LABORATORY INFORMATION (INFORMACIÓN SOBRE LA COMPAÑIA DE PRUEBAS DE POLVO Y EL LABORATORIO)

Co. NAME (NOMBRE DE LA COMPAÑIA):	CONTACT PERSON (PERSONA A CONTACTAR):
ADDRESS (DIRECCIÓN):	CITY (CIUDAD): STATE (ESTADO): ZIP (ZONA POSTAL):
PHONE (TEL): ()	FAX: ()
SIGNATURE (FIRMA):	EPA CERTIFICATE No. (FOR DUST WIPE SAMPLING): <small>(EPA No. DE CERTIFICADO PARA LAS PRUEBAS DE POLVO)</small>

LABORATORY NAME FOR SAMPLE ANALYSIS:

NYS DOH ELAP No.:

<small>NOMBRE DEL LABORATORIO PARA EL ANÁLISIS DE MUESTRAS</small>	
ADDRESS (DIRECCIÓN):	CITY (CIUDAD): STATE (ESTADO): ZIP (ZONA POSTAL):
PHONE (TEL): ()	FAX: () SIGNATURE (FIRMA):

(For internal use only.) (Para uso interno solamente)

LASU No.:

