



# **Al Qalam: Poets in the Park**

## **Sara Ouhaddou**

Elizabeth H Berger Plaza

August 14, 2023

Presented by Washington Street Historical Society  
Sara Ouhaddou and UAP Company

# **Parks**

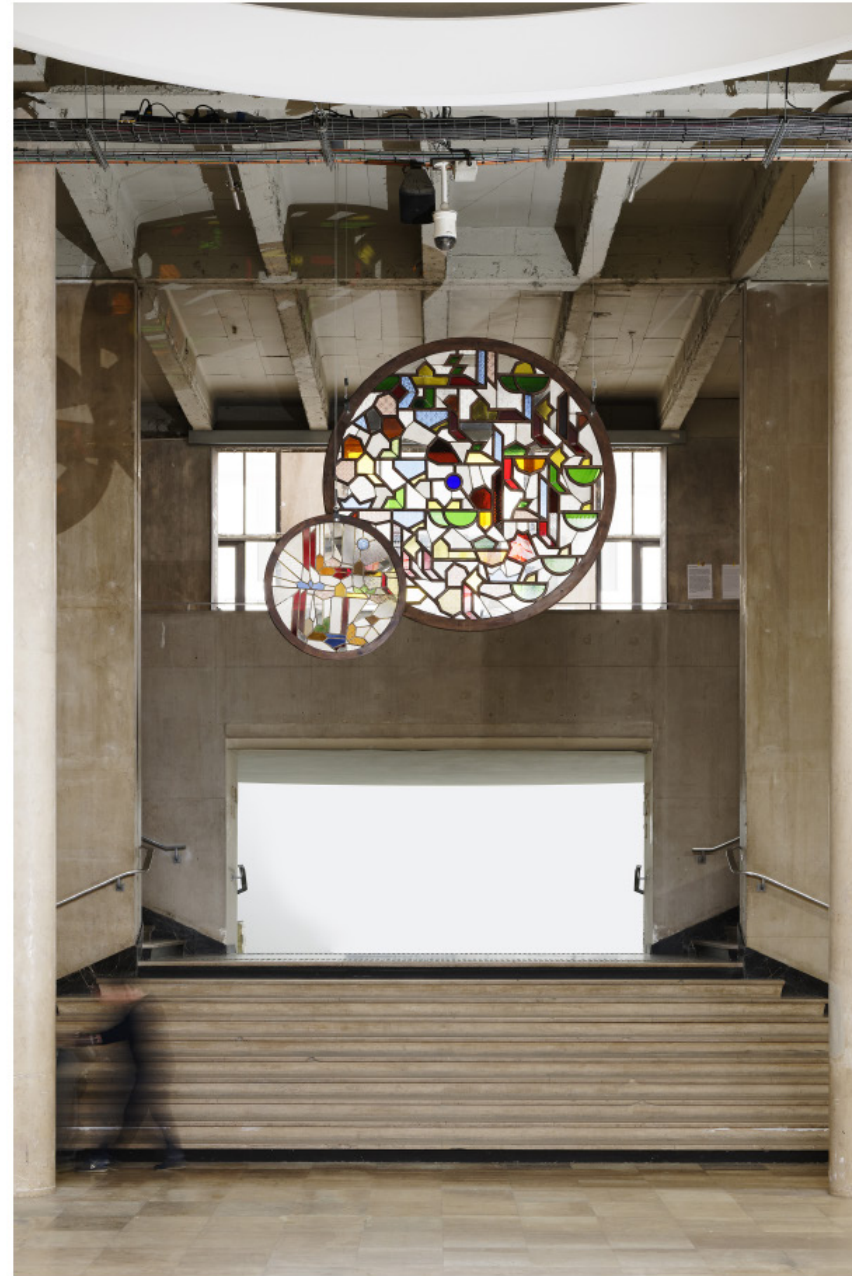

**Al Qalam: Poets in the Park**  
Elizabeth H. Berger Plaza | Past works

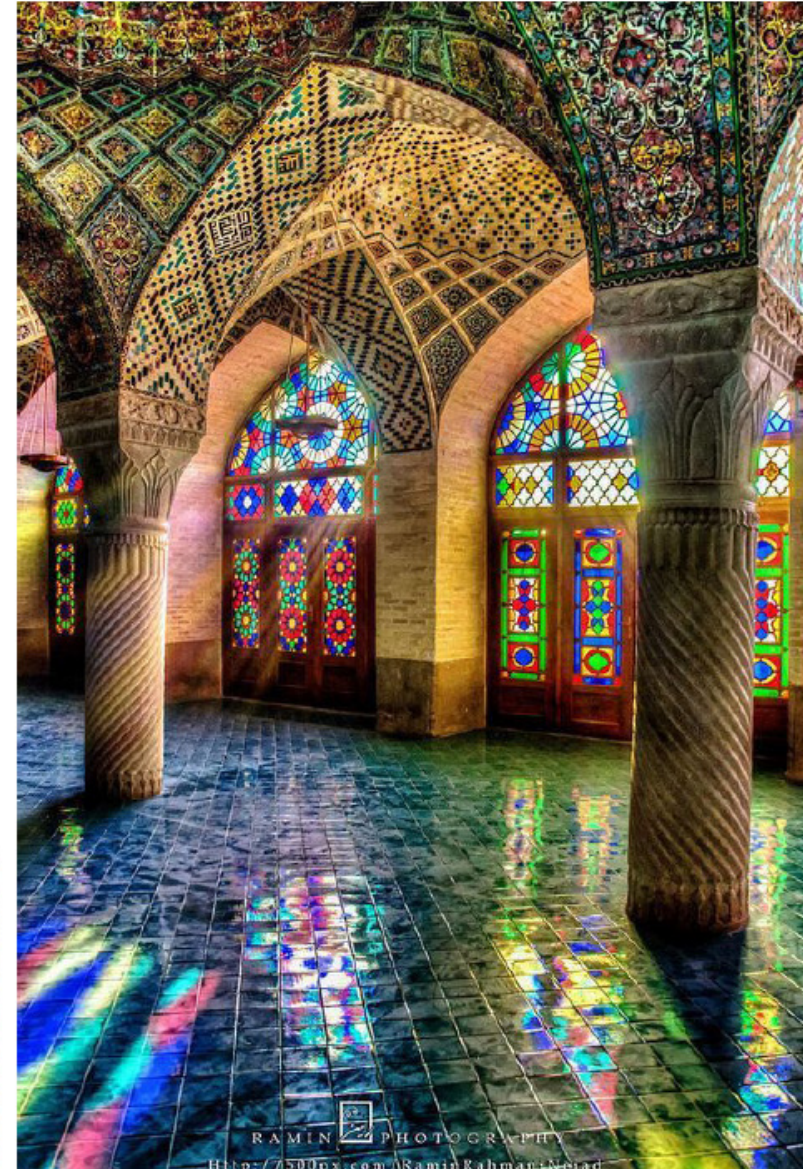
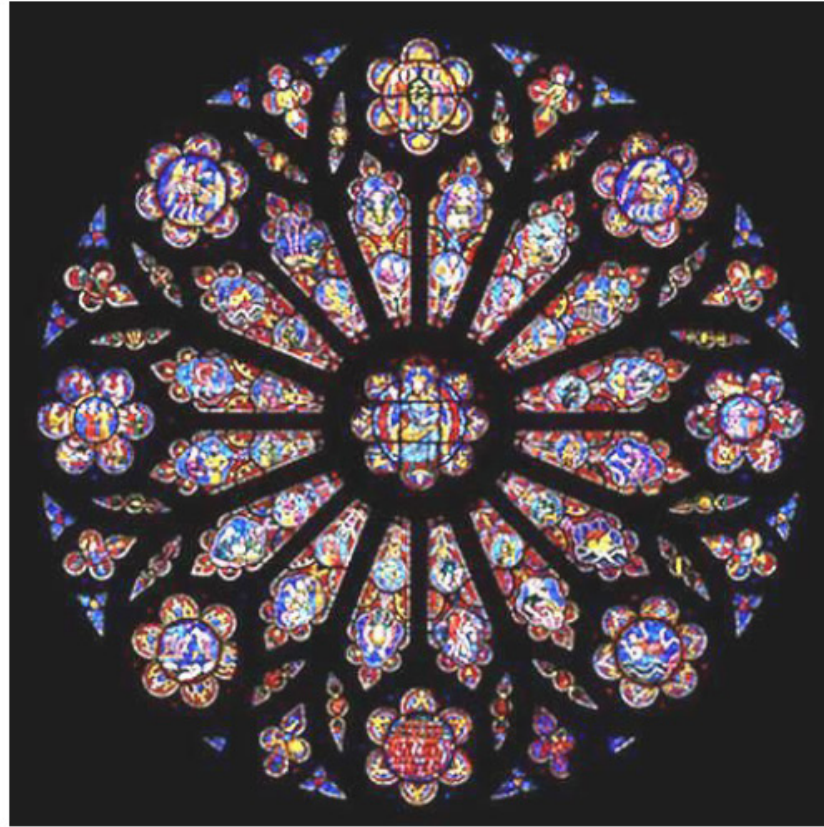

INSPIRATIONS - SPIRITUALITY - UNIVERSALISM  
Colorful mosaics made of glass will replace glass itself and marble.



## Al Qalam: Poets in the Park Elizabeth H. Berger Plaza | Inspiration

Lynn Basa by Mosaika

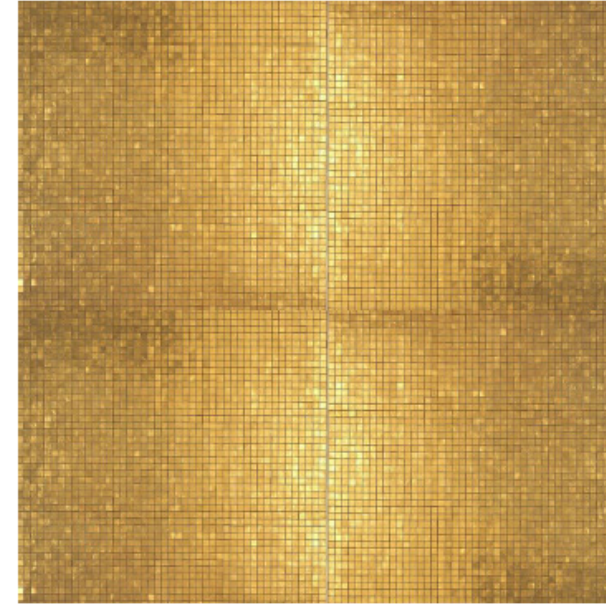

Klimt



Katy Fischer by Mosaika



Katy Fischer by Mosaika



INSPIRATIONS



**Al Qalam: Poets in the Park**  
Elizabeth H. Berger Plaza | Inspiration

# The Genesis of Al Qalam: Poets in the Park

Washington Street Historical Society

- In the late nineteenth and early twentieth centuries, the Lower West Side of Manhattan was home to a vibrant Arabic-speaking community called “the Syrian Quarter” or “Little Syria.”
- The neighborhood was the heart of a literary flowering, producing poets and writers who changed Arabic and American literature. The Al Qalam: Poets in the Park project celebrates these writers in Elizabeth H. Berger Plaza, located just steps away from their original home on Washington Street.
- The Project comprises two seat walls with quotations of some of the members of The Pen Bond (Arabic: al Rabitah al Qalamiyyah), founded in 1920 by Kahlil Gibran and others.
- Two women, Afifa Karam and Agabia Maloof, though not members of the all-male Pen Bond, are also represented as they were important members of the literary community.
- The sculpture celebrates these writers, first, by spelling out the Arabic word, al Qalam, which means “Pen” in Arabic, and second by inscribing their names in the letters of the sculpture.



# Project Statement

- I have a great interest in the history of language and writing, from the origin of human modes of expression to their transformation through time and cultures.
- The project I am proposing here is a natural continuation of my research, but above all it is in keeping with the philosophy of the poets of this era of enlightenment in the Arab world.
- I have invented an abstract alphabet at the crossroads between the literary Arabic alphabet and Islamic geometry.
- The level of abstraction also embraces the philosophy of calligraphy, which is not read, but felt.
- At a time when it is more and more complicated to come from the Arab community, we have chosen poems that are unifying and of universal consideration.
- The work is a tribute to this exceptional group of poets, as well as a space of recognition for the history of the community of Little Syria, which created, invented, imagined, came to this neighborhood. A space of memory.
- The gentle curve of the sculpture follows the meandering path of planting bed and decorative stone on walkway. The seat walls also incorporate this language by following the arc of the stone planting bed walls and provide an additional seating area for the passerby.

- Sara Ouhammadou



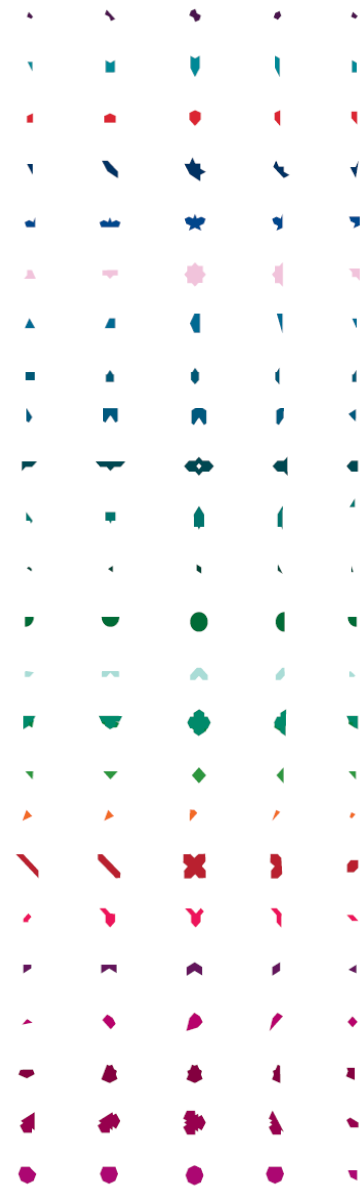

Islamic Geometry

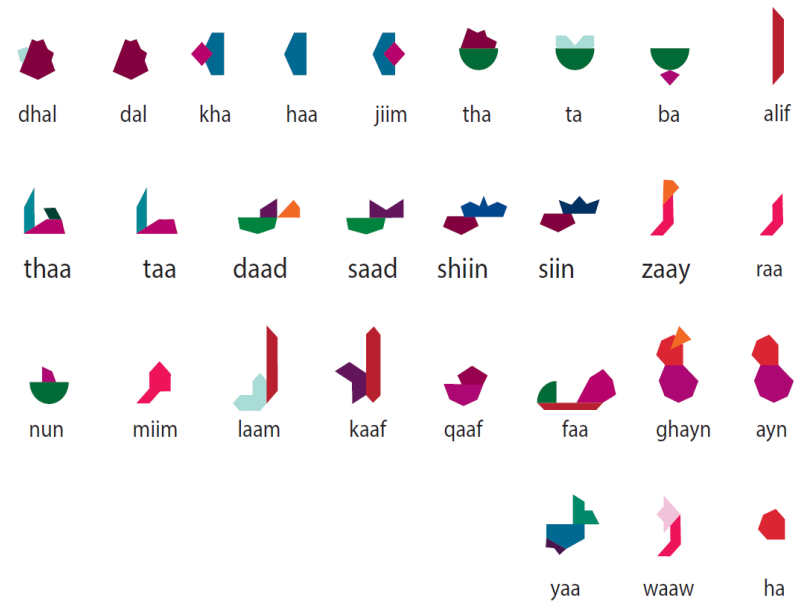

Syntax alphabet



Translation from Arabic to Syntax Alphabet



**Al Qalam: Poets in the Park**

Elizabeth H. Berger Plaza | Sara Ouhaddou's Syntax of the Arab Alphabet



Manhattan

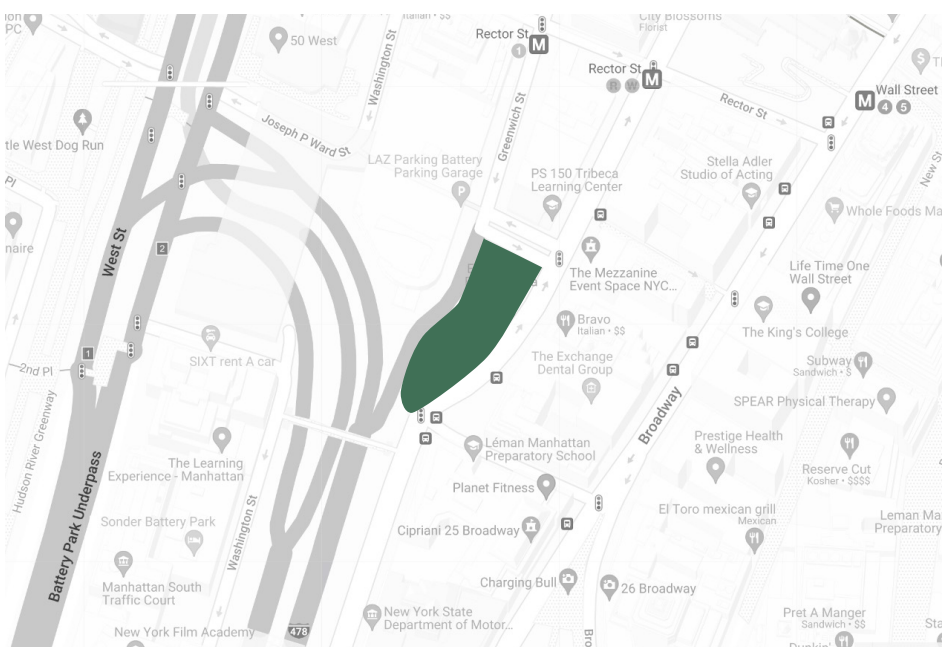

Neighborhood



Site



NYC Parks

**Al Qalam: Poets in the Park**  
**Elizabeth H. Berger Plaza | Project Location**



NYC Parks

## Al Qalam: Poets in the Park Elizabeth H. Berger Plaza | Site Photos



NYC Parks

## Al Qalam: Poets in the Park Elizabeth H. Berger Plaza | Site Photos



**Al Qalam: Poets in the Park**  
Elizabeth H. Berger Plaza | Site Photos



**Al Qalam: Poets in the Park**  
Elizabeth H. Berger Plaza | Site Photos

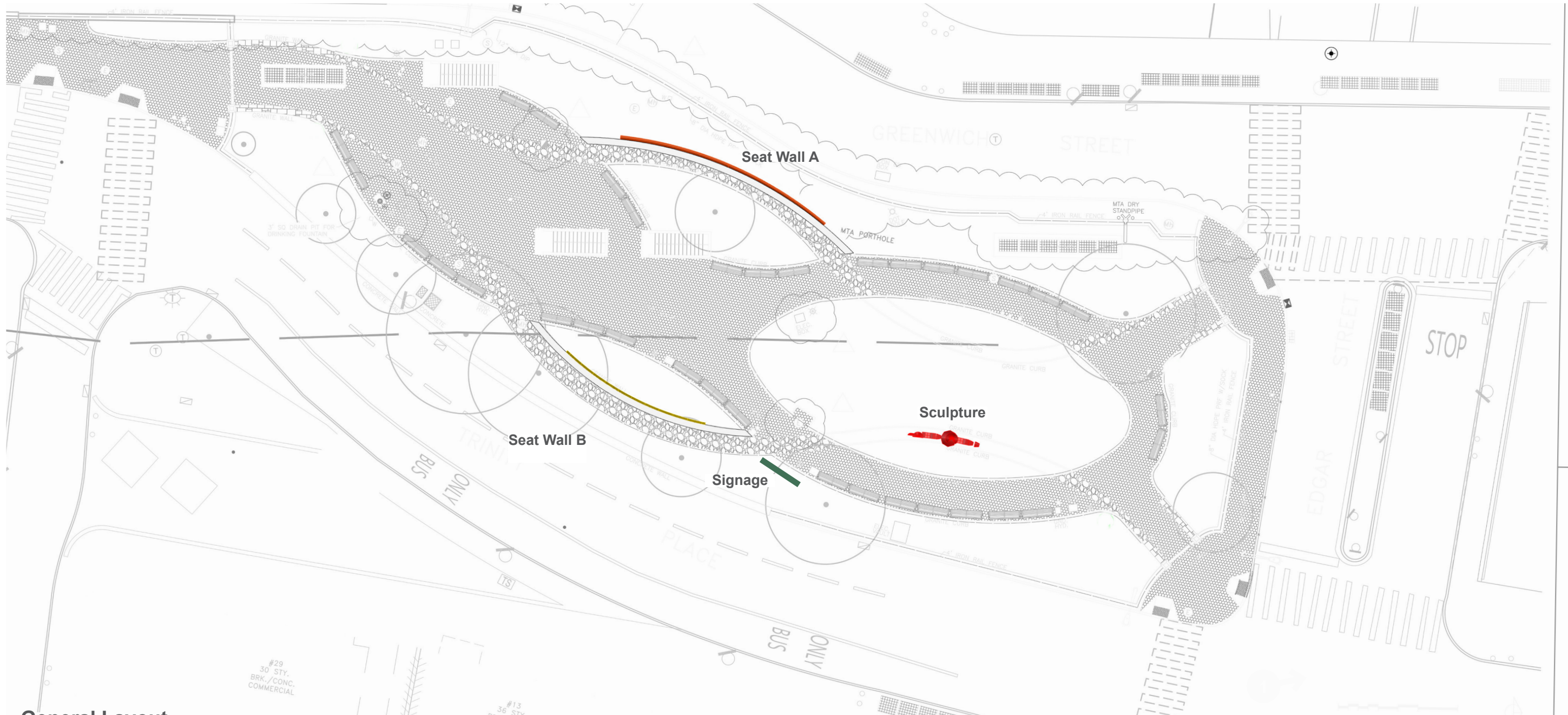

General Layout



NYC Parks

**Al Qalam: Poets in the Park**  
**Elizabeth H. Berger Plaza | Placement of Artwork**





**Al Qalam: Poets in the Park**  
**Elizabeth H. Berger Plaza | Seat Wall A**



**Al Qalam: Poets in the Park**  
**Elizabeth H. Berger Plaza | Seat Wall A**

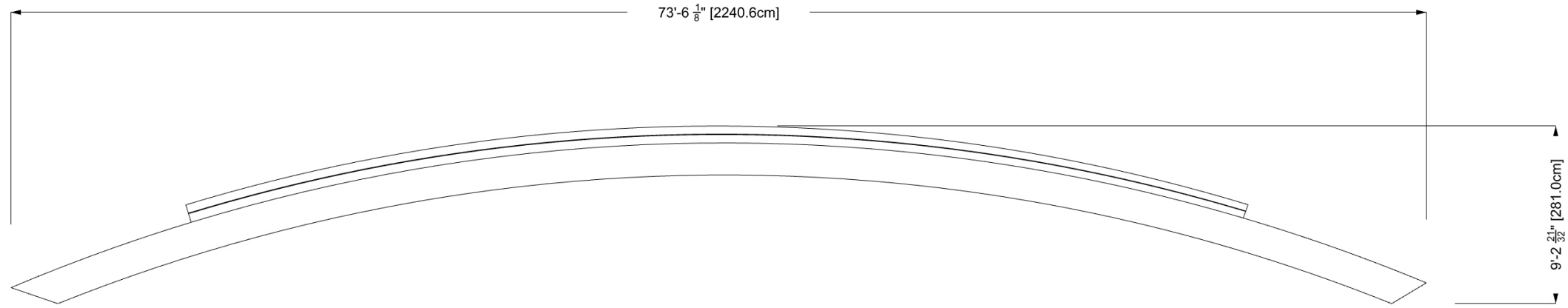

Top

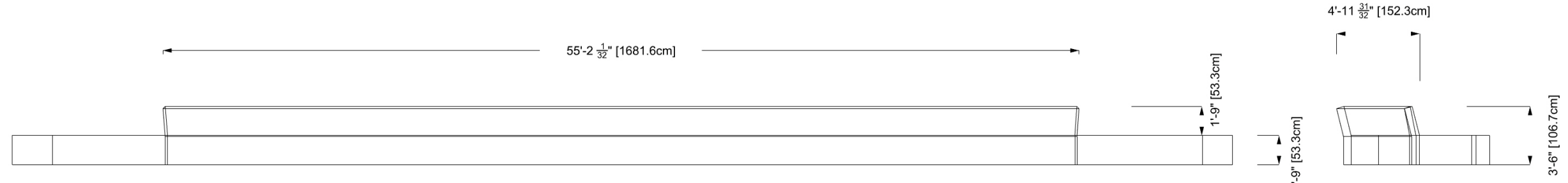

Front

Right



**Al Qalam: Poets in the Park**  
**Elizabeth H. Berger Plaza | Seat Wall A General Dimensions**



**Al Qalam: Poets in the Park**  
Elizabeth H. Berger Plaza | Seat Wall B



**Al Qalam: Poets in the Park**  
**Elizabeth H. Berger Plaza | Seat Wall B**

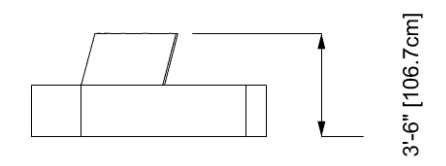
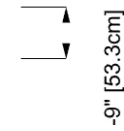
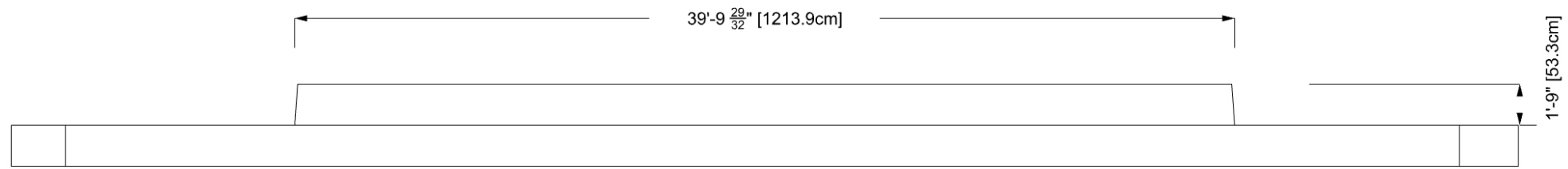
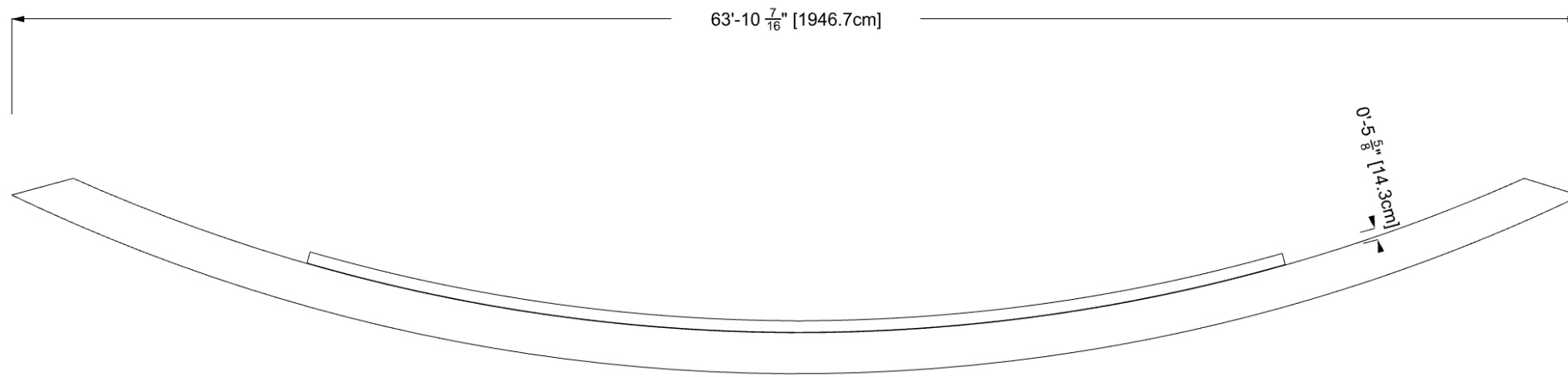

**Al Qalam: Poets in the Park**  
**Elizabeth H. Berger Plaza | Seat Wall B General Dimensions**

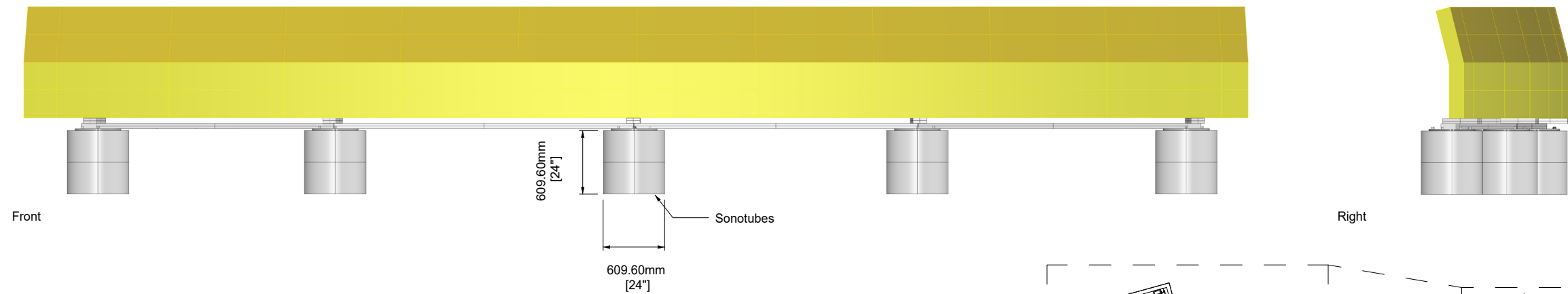

Front

Right

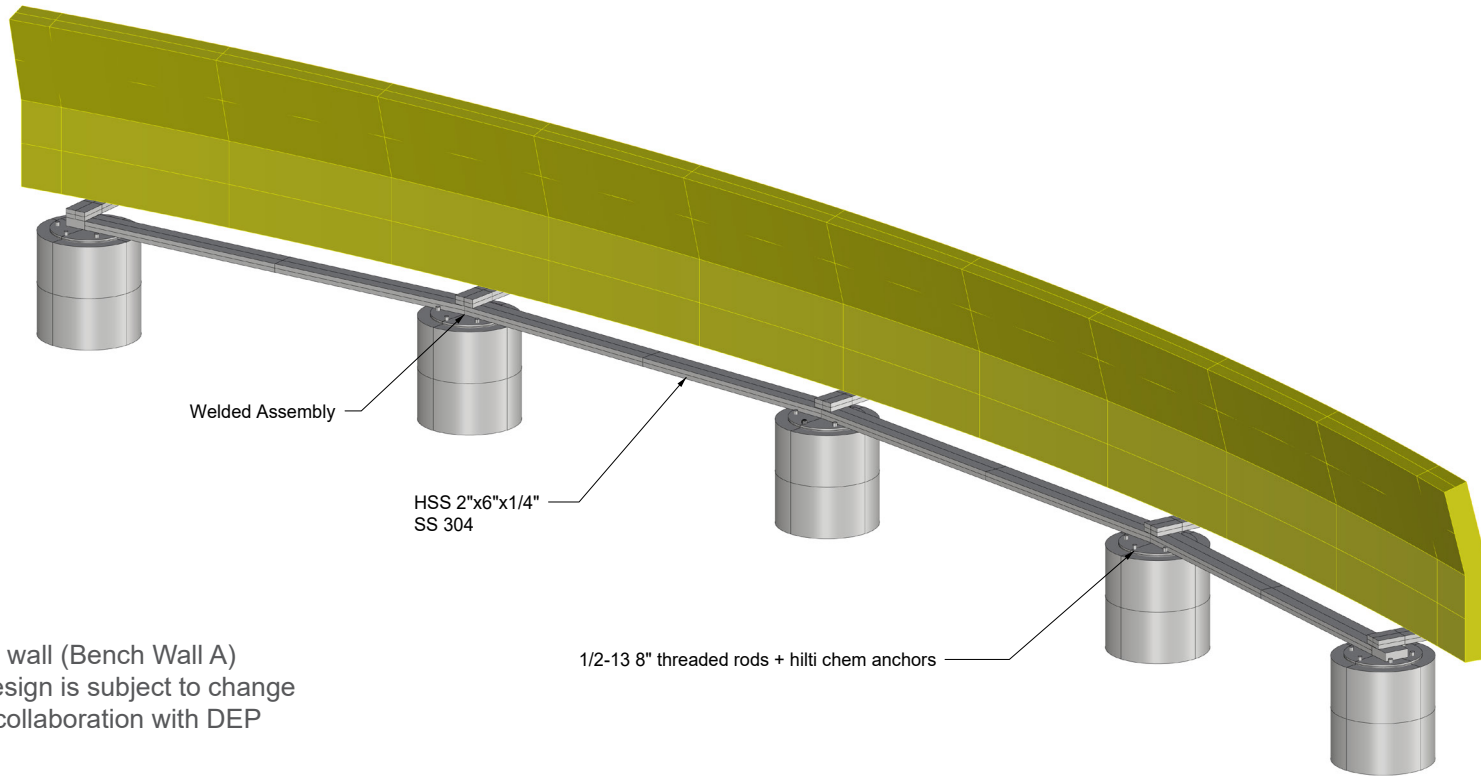

Welded Assembly

HSS 2"x6"x1/4"  
SS 304

1/2"-13 8" threaded rods + hilti chem anchors

Western wall (Bench Wall A)  
anchorage design is subject to change  
based on collaboration with DEP

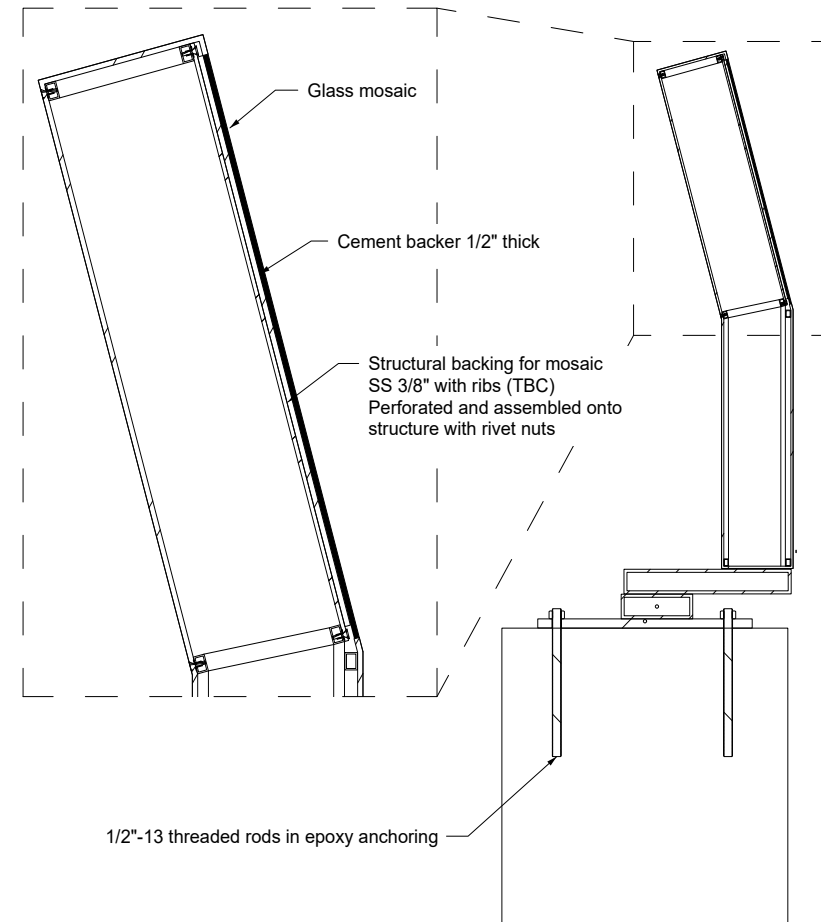

1/2"-13 threaded rods in epoxy anchoring



**Al Qalam: Poets in the Park**  
Elizabeth H. Berger Plaza | Seat wall Technical Details



**Al Qalam: Poets in the Park**  
Elizabeth H. Berger Plaza | Sculpture



**Al Qalam: Poets in the Park**  
Elizabeth H. Berger Plaza | Sculpture



NYC Parks

**Al Qalam: Poets in the Park**  
Elizabeth H. Berger Plaza | Sculpture



## Front View



NYC Parks

### **Al Qalam: Poets in the Park** **Elizabeth H. Berger Plaza | Sculpture**

Alqalam | The Pen

Nassib Aridah, Agabia Malouf, Gibran Kahlil Gibran, Nadra Haddad, Abbas Abu Shakra, Elia Abu-Madey, Mikhail Naimy, Amin Rihani, Afifa Karam



Back View



NYC Parks

**Al Qalam: Poets in the Park**  
Elizabeth H. Berger Plaza | Sculpture

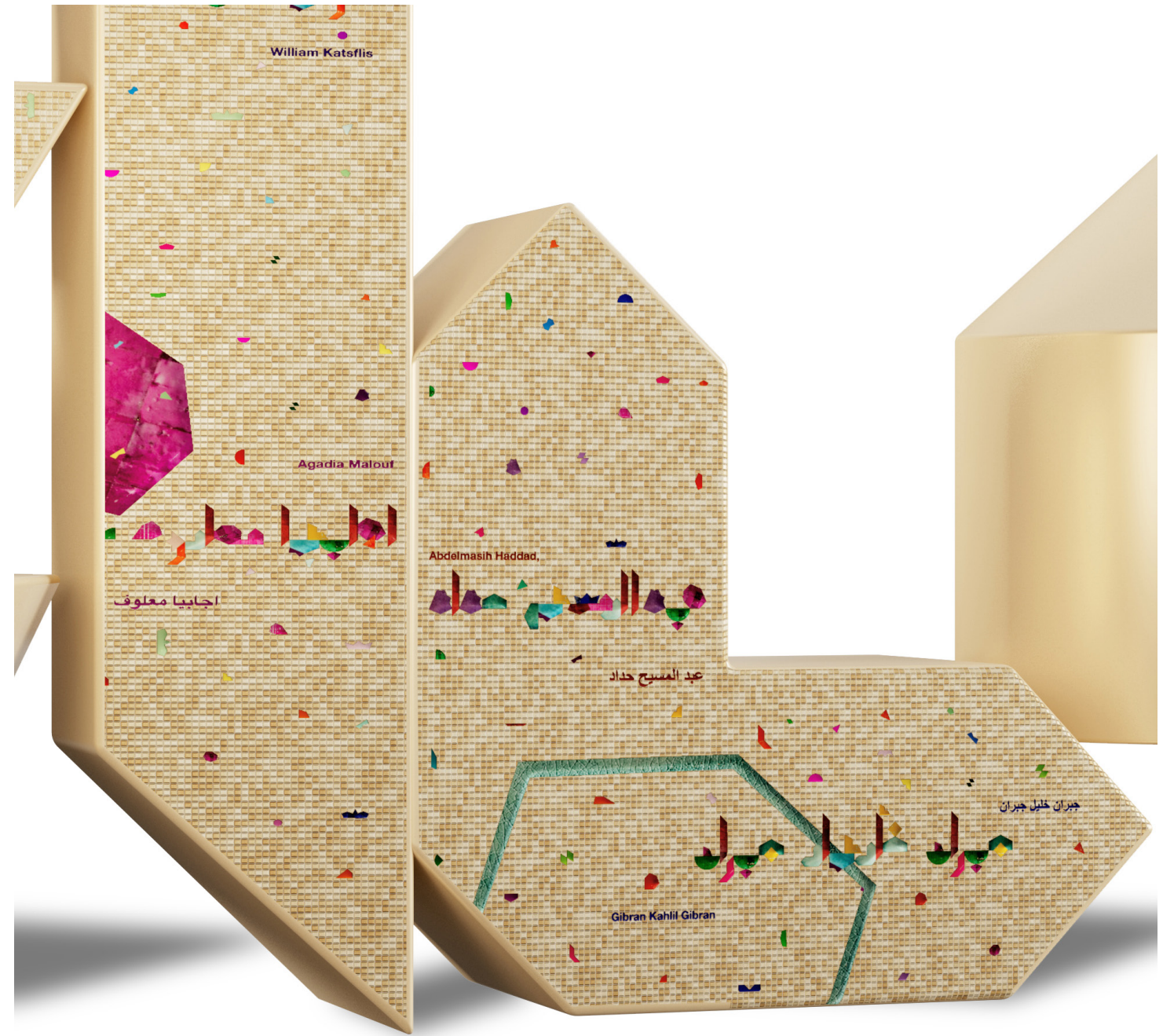
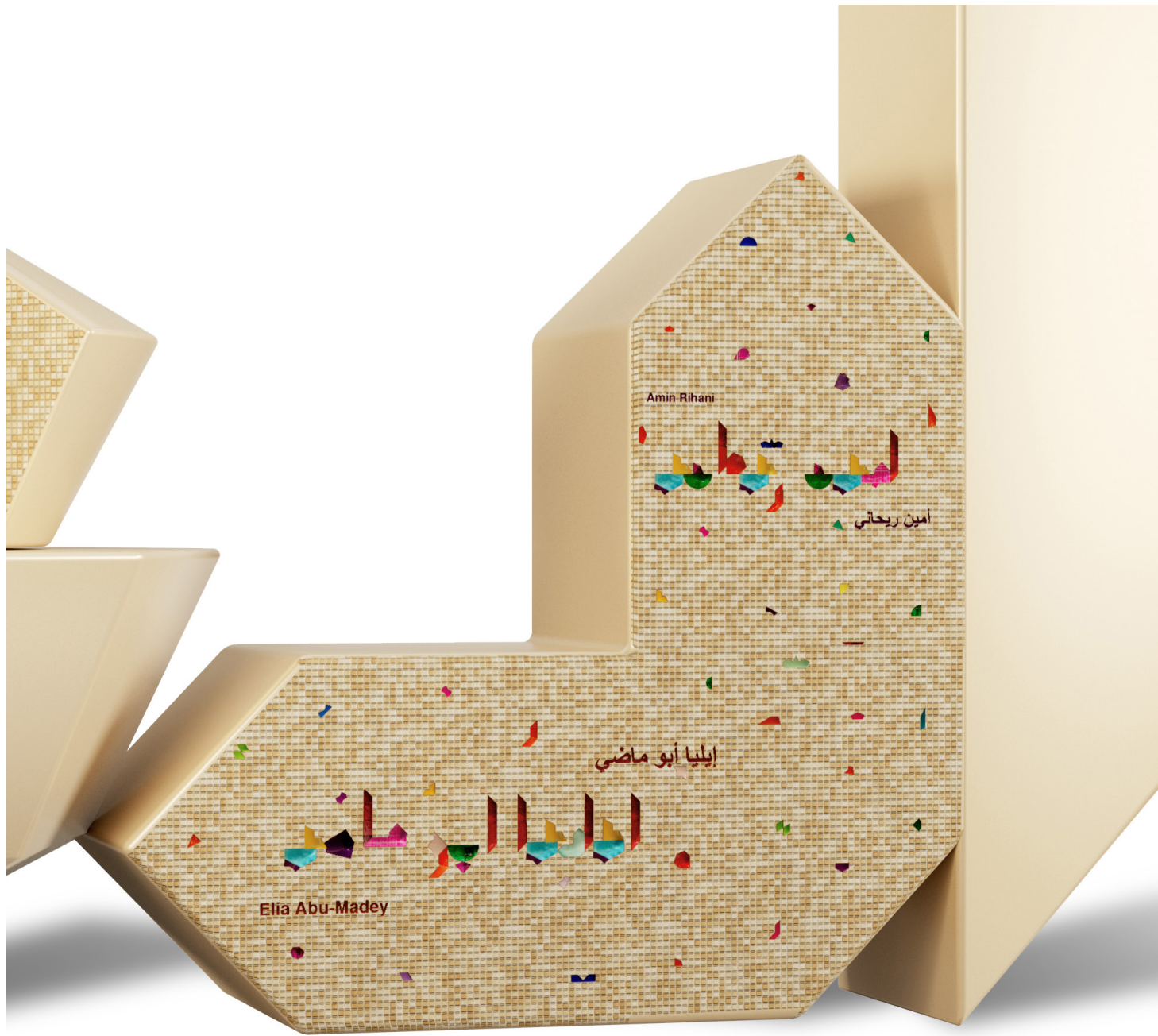

Details



Al Qalam: Poets in the Park  
Elizabeth H. Berger Plaza | Sculpture

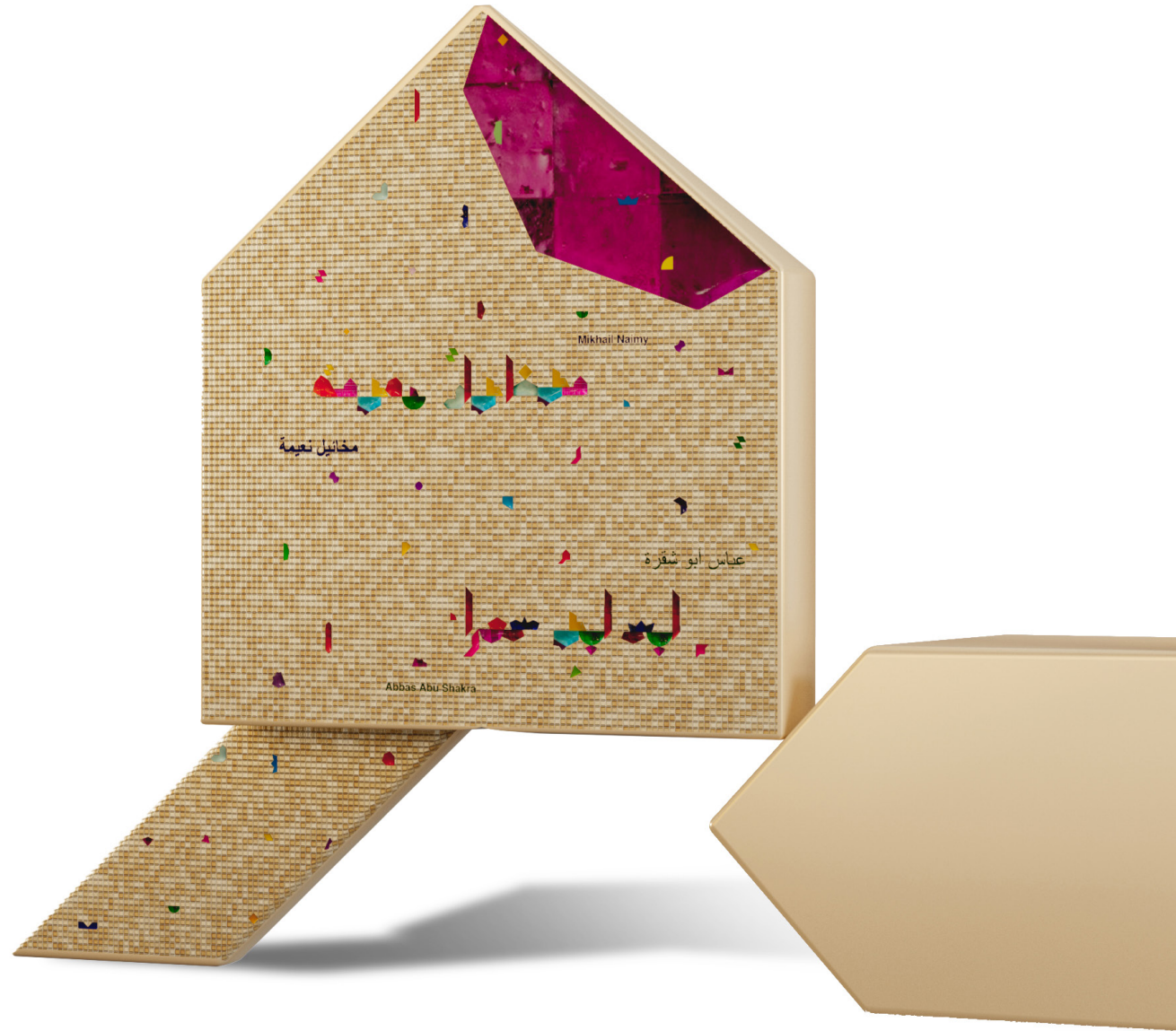

## Details



NYC Parks

**Al Qalam: Poets in the Park**  
Elizabeth H. Berger Plaza | Sculpture

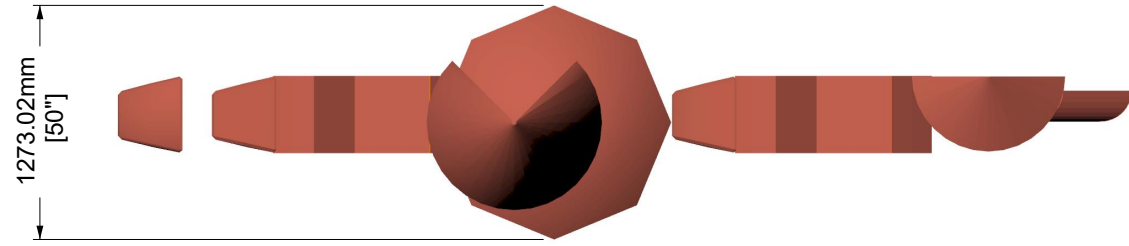

TOP VIEW

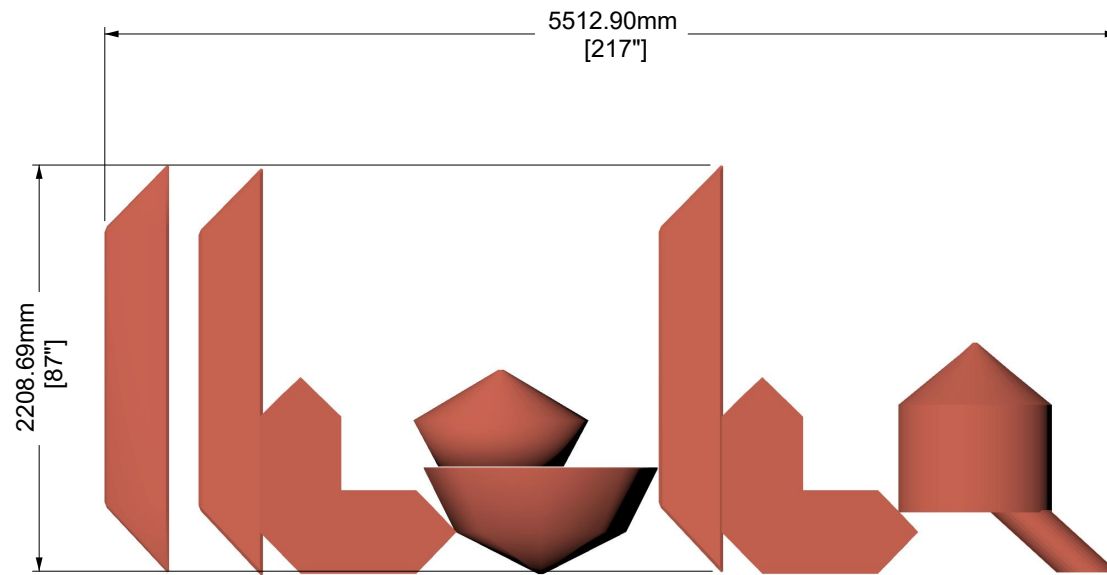

BACK VIEW

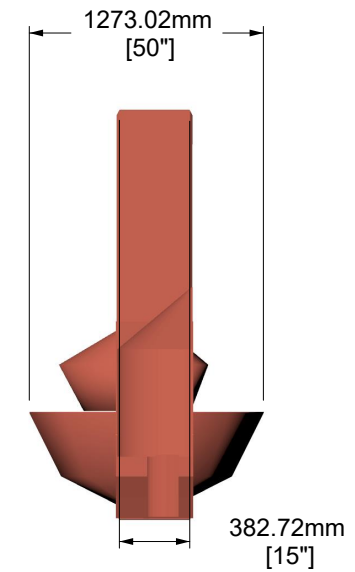

**Al Qalam: Poets in the Park**  
 Elizabeth H. Berger Plaza | Sculpture General Dimensions



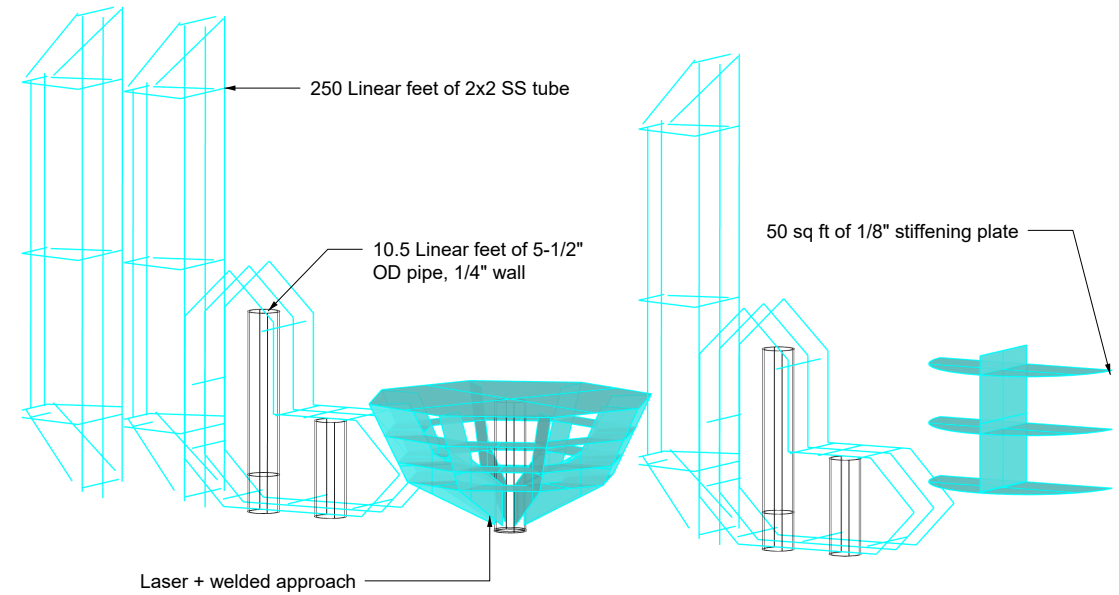
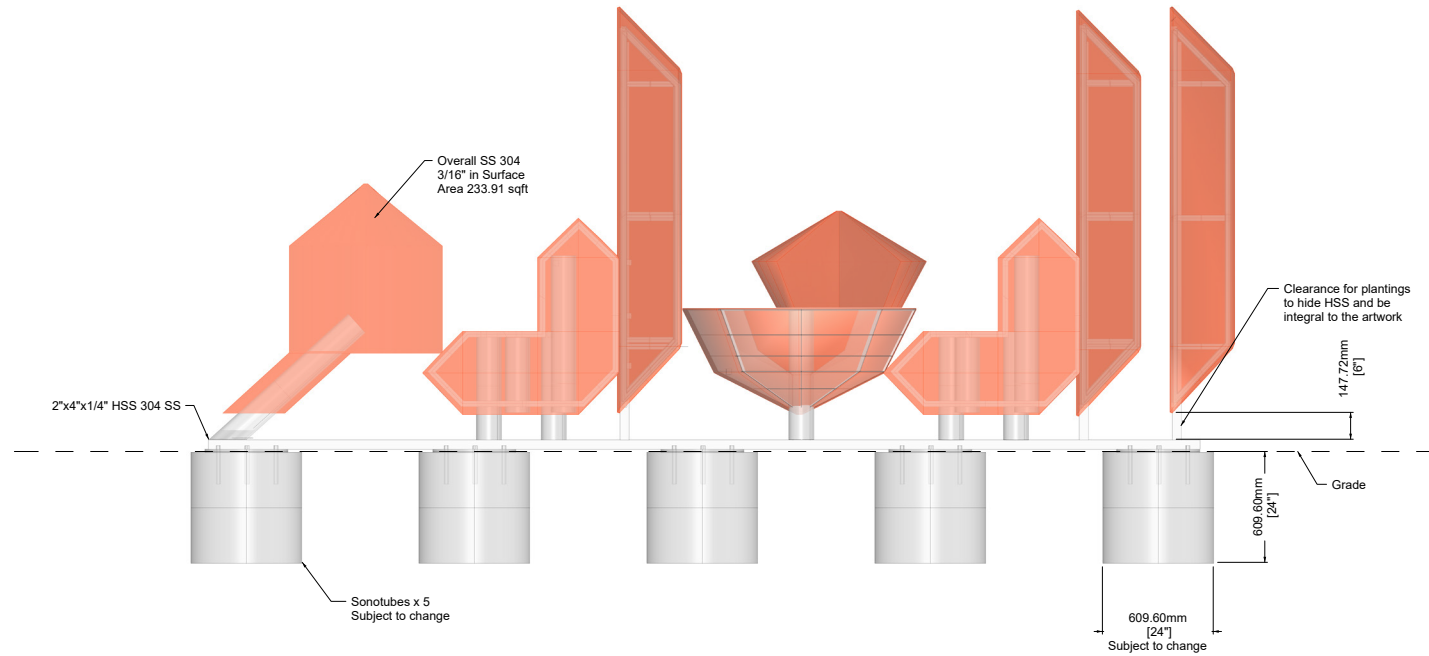
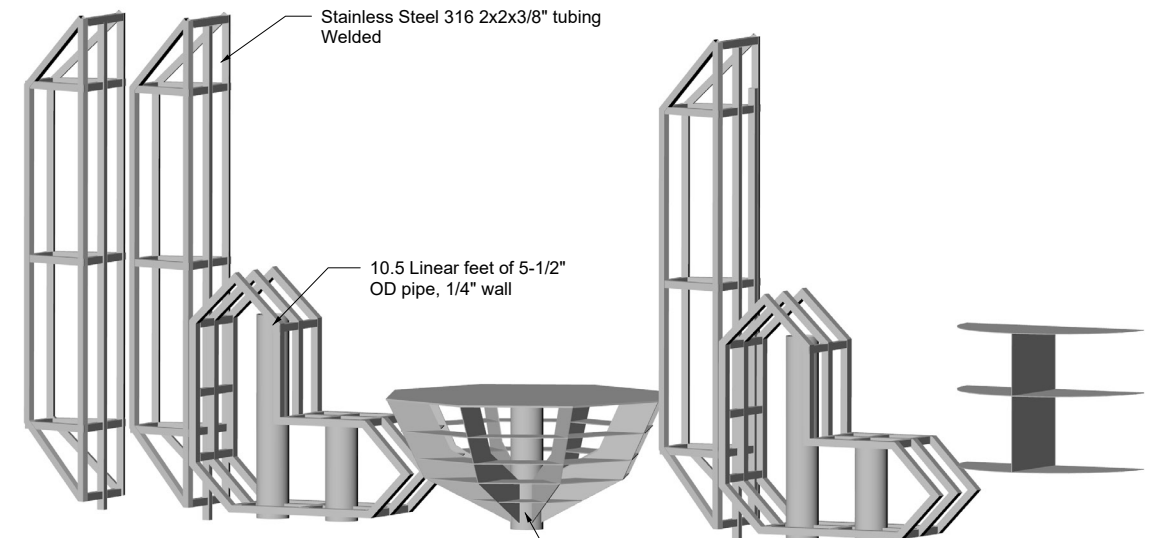
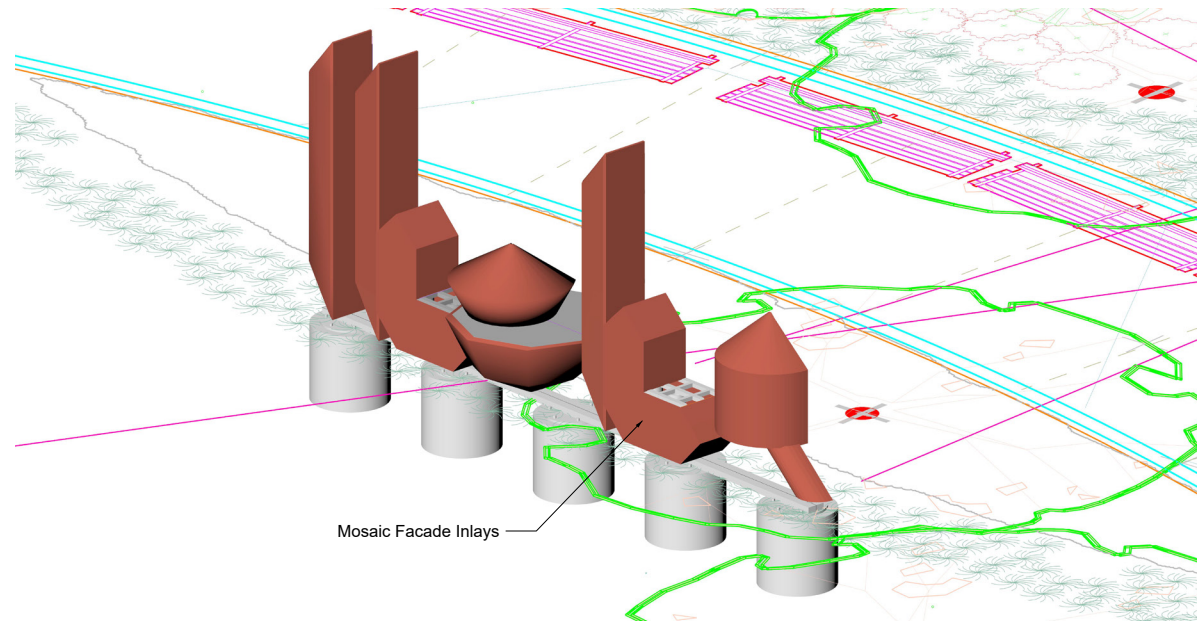

**Al Qalam: Poets in the Park**  
**Elizabeth H. Berger Plaza | Sculpture Technical Details**



A

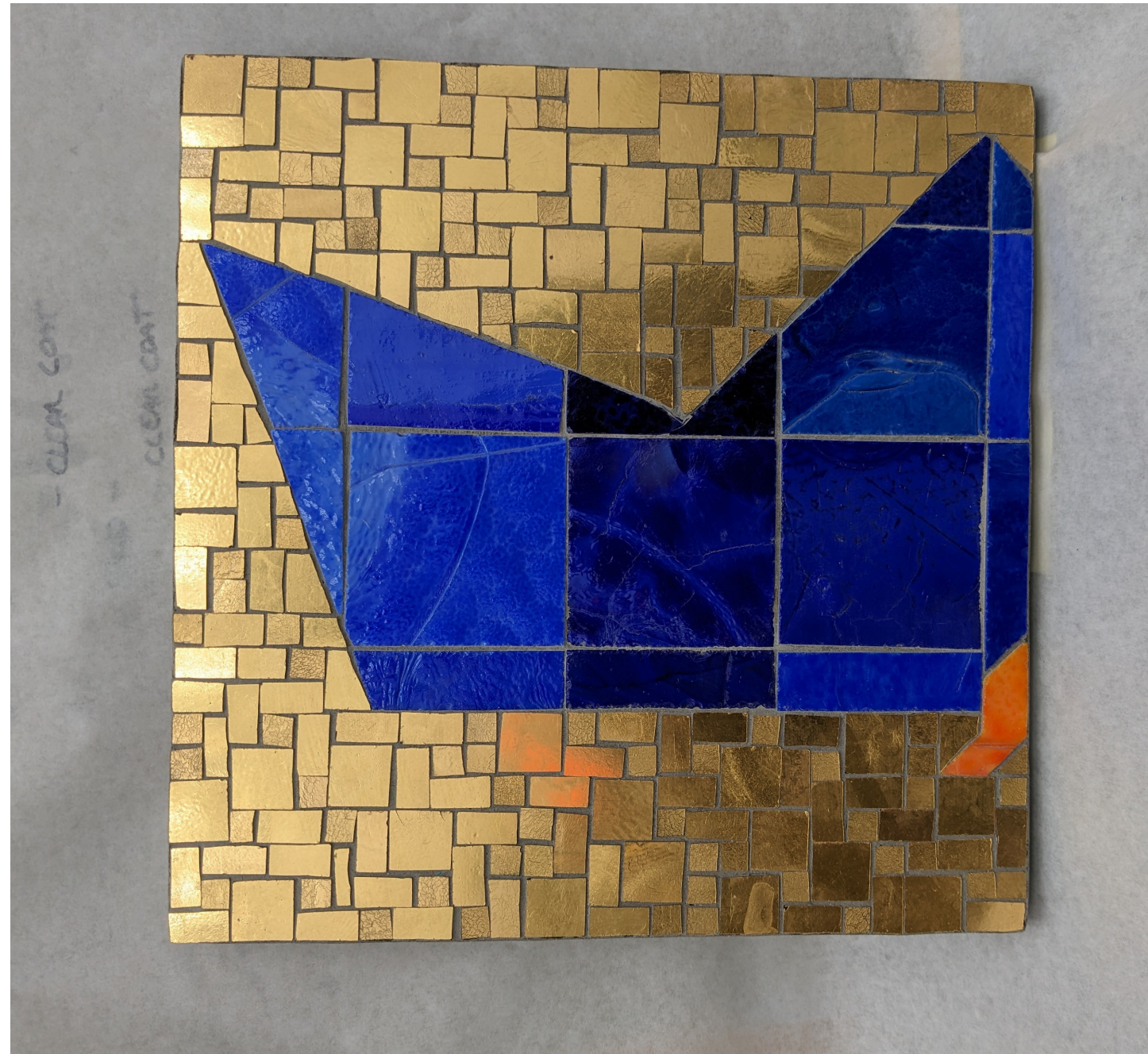

B



**Al Qalam: Poets in the Park**  
Elizabeth H. Berger Plaza | Mosaic Samples

# AL QALAM - POETS IN THE PARK

## ELIZABETH H. BERGER PLAZA

Just steps away from this park, the first Arabic-speaking community in the United States took root. Between 1880 and 1945, when the neighborhood was destroyed by the construction of the Brooklyn Battery Tunnel, immigrants from present-day Lebanon and Syria made their home on Washington Street between The Battery and Albany Street. Known to New Yorkers as "the Syrian quarter" or "Little Syria," about 1500 immigrants lived on Washington Street. Their homes were crowded tenements that had been carved from single-family residences built in the early nineteenth century. Like their Irish, German, and Eastern European neighbors, the Syrians lived with no indoor plumbing and no access to fresh air or light. Infant mortality rates were tragically high. Yet the Syrians not only survived but thrived.



1923. Their writing and that of other members of the community played an important role in the literary renaissance in the Middle East, radically transforming the Arabic language, inspiring generations of later writers in the United States and the Middle East and creating innovative forms of Arabic literature. Women were not members of al Rabitah but were nevertheless respected members of the literary community, and two are included in this commemoration, Afifa Karam and Agabia Malouf.

Most of them peddled when they first arrived, but by 1900, the street boasted Arabic shops, factories, and restaurants; four chapels; a Syrian school to teach adults English and children American history; and a half-dozen Arabic newspapers. Musicians and poets were respected members of the community, performing extemporaneously at weddings, baptisms, and social gatherings. Poetry was regularly published in the newspapers and by the early twentieth century, the Syrians had begun to publish books and magazines in both Arabic and English. Among these writers were Kahlil Gibran, Ameen Rihani, Nassib Arida, and Ilya Abu Madi, who were instrumental in the formation of a writers' association called al Rabitah al Qalamiyah (The Pen Bond).

Formed first in 1916 and reconstituted in 1920, al Rabitah al Qalamiyah produced works of fiction, poetry, and visual art that imagined new ways of being Arab and American. Their most famous work, The Prophet by Kahlil Gibran, was published in

Washington Street Historical Society has commissioned the artwork in Elizabeth H. Berger Plaza to celebrate the literary legacy of New York's first Arabic-speaking community. The Moroccan French artist Sara Ouhaddou has designed the mosaic panels displaying excerpts from their work in an abstract alphabet created by her. The sculpture on the edge of the central mound spells out the Arabic word, al Qalam, the Pen.

Scan the QR Code for more information on the artwork and the poets of the Pen Bond or a virtual tour of the historic Syrian neighborhood.

Washington Street Historical Society.



# AL QALAM - POETS IN THE PARK

## ELIZABETH H. BERGER PLAZA

Artworks locations

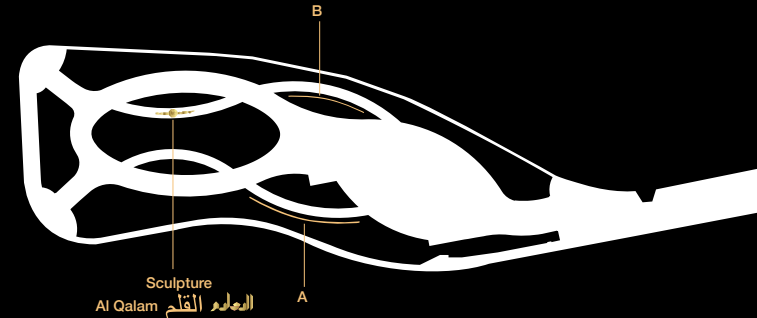

Sculpture  
Al Qalam القلم

Al Qalam Alphabet by Sara Ouhaddou :

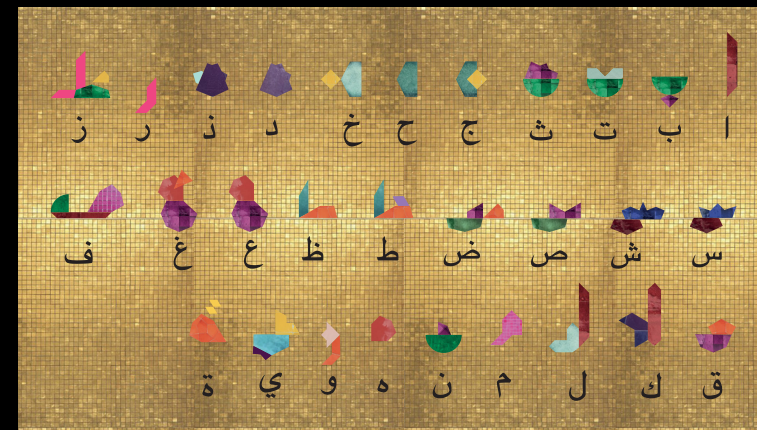

# AL QALAM - POETS IN THE PARK

## ELIZABETH H. BERGER PLAZA

Translations

*please refer to map key at left*

Wall A :

Naseeb Arida

*I adopted America as my beloved homeland. I wanted of her a life of freedom. And that I have found.*

اتخذتُ أمريكا وطناً عزيز  
طلبتُ بها حياة  
مع الحرية المثلى فالت. نصيب عرادة

Agabia Malouf

*It is for us in the American diaspora to study the meaning of freedom and carry it back home.*

يجب علينا نحن الذين في المهجر أن ندرس  
معنى الحرية ونحملها إلى تلك الديار ولا نكل  
من مناصرة وطناً يدعونا لمناصرتة.  
أغابية مخلوف

Afifa Karam

*Woman is the oldest and greatest of all schools known to humanity.*

المرأة أقدم وأعظم المدارس المعروفة للإنسان.  
عفيفة كرم

Abbas Abu Shakra

*Behold the Cedar Tree, rooted in the East, extending her sheltering shade to the West.*

لمن شجره خضراء في الشرق أصلها ولكنما  
للغرب يمتد ظلها. عباس أبو شقرة

Mikhail Naimy

*Love is the essence of life. When people love, all shades of ugliness will shrink away, and they will see that everything within them is beautiful.*

الحب خلاصة الحياة، فمتى تقلصت عنهم كل  
ظلال الشناعة فرأوا كل ما فيهم جميلاً، ومتى  
رأى الناس كل ما فيهم جميلاً عرفوا الحب،  
ومتى عرفوا الحب عرفوا الحياة. ميخائيل نعيمة

Wall B :

Ilya Abu Mady

Be a Balm.

*Do good, though you may not be recompensed by a word of thanks. What reward does rain expect when it falls? Who rewards the scent-giving flower? Who repays the singing nightingale? Friend, learn love from them.*

كن بلسماً  
أحسن وإن لم تُجزَ حثى بالتنا  
أيّ الجزاء الغيثُ يبغى إن همى  
من ذا يكافئ زهرة فواحة  
أو من يُثيب البُلبُل المُنترماً  
يا صاح خذْ عِلْمَ المَحَبَّةِ عنهُما.

إيليا أبو ماضي

Nadra Haddad

*I left my homeland but kept in my heart its likeness, and also its name.*

فرقتَه فحفظت رسمه في مهيجتي  
وكذلك اسمه. نادرة حداد

Kahlil Gibran

*The whole earth is my homeland, and the human family is my tribe.*

الأرض كلّها وطني ولعائلة البشرية عشيرتي.  
جبران خليل جبران

Amin Rihani

*The light! The light! Let it blaze in our hearts. And should the world darken, let that light stream outwards from our hearts, even if the whole horizon is gloom.*

النور! النور! ليسطع في قلوبنا، وإن أظلم  
العالم لينتشر من قلوبنا، وإن اكفهرت الأفق  
كلها. أمين الريحاني



Al Qalam: Poets in the Park  
Elizabeth H. Berger Plaza | Signage

NYC Parks

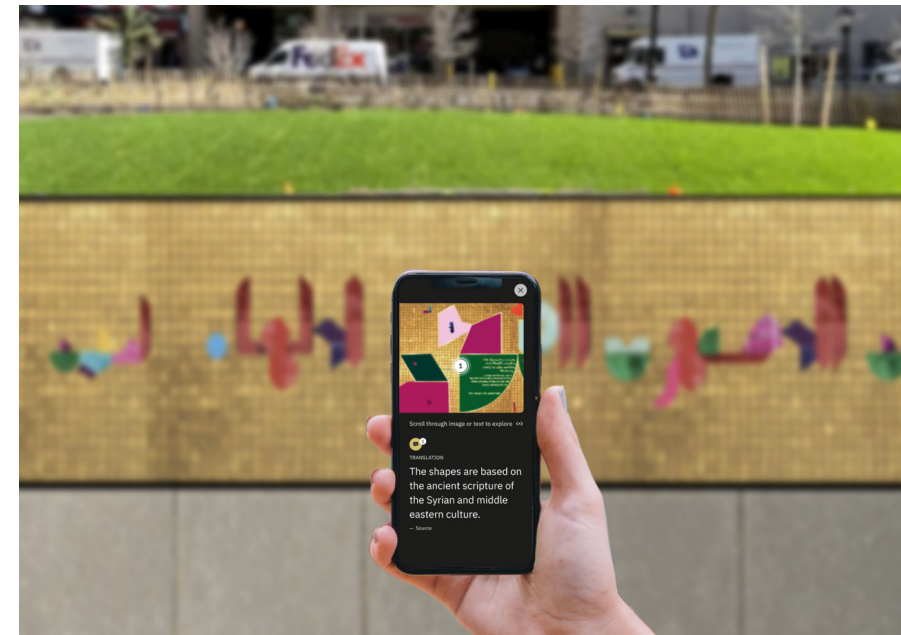

**Al Qalam: Poets in the Park**  
**Elizabeth H. Berger Plaza | Smart Phone Application**

# Maintenance

## ARTWORK

The artwork will consist of a series of (2) bench walls and a sculpture. The medium of all elements is clear coated painted stainless steel and mosaic. Cleaning as outlined below will be required annually, although at times further cleaning and maintenance may be necessary due to unforeseen environmental factors, misuse, or vandalism.

## ANNUAL CLEANING INSTRUCTIONS

### MOSAIC

Little maintenance is generally required for glass mosaics other than periodic cleaning. This should be done with a soft brush and a cleaner such as Dirtex, followed by a rinsing with clean water. Never use a pressure washer on a mosaic.

### PAINTED STAINLESS STEEL

Rinse the sculpture with clean, clear water using a microfiber cloth or soft sponge. Use non-ionic detergent such as Orvus. Proprietary mild detergents such as Dawn can be used, however proprietary formulations are subject to change so testing should be carried out in an inconspicuous area prior to overall cleaning. Dry with gentle air pressure or with clean microfiber cloths. Aggressive rubbing during washing or drying may burnish ie. increase the sheen of the shine.

## ANNUAL STANDARD CLEANING

It is expected that the annual cleaning will require a team of 3 for 1 day. Duration depends on the level of cleaning required. The annual cost for a standard soap and water cleaning for general wear and tear for the sculpture and mosaic panels of the Project, Rabitah: Poets in the Park, will be covered by Washington Street Historical Society, the funder and steward of the Project. WSHS commits to providing the amount on an annual basis to ensure the art is conserved in perpetuity. WSHS has funding for the first two years of annual cleaning up to \$5000 a year for two years, and once we determine the actual cost of such, we will set up an escrow fund.

Exclusions: Cleaning beyond standard processes described above, Off-site fabrication of replacement parts, On-site fabrication, or repair of damaged components beyond cleaning or standard graffiti removal, painting beyond minor touch-up paint, full structural review, full conditions report, travel expenses. Please see repair estimates below.



# Maintenance

## CONCERNS

### GRAFFITI

#### Mosaics

Most paints and markers can be cleaned off the glass tesserae easily. Blot acetone onto a soft microfiber cloth or soft sponge and rub gently. For more stubborn markings, a lacquer thinner will also work. Never apply a clear coat or other preventive coating over the mosaic. It will dull or cloud the color.

#### Stainless Steel

UAP will apply a catalyzed and hardened two component urethane clear coat to all metal components after powder coat. This creates a layer of protection. Solvent based inks such as graffiti can be easily wiped off. UAP will also provide a touch up bottle of paint and clear coat to Parks should metal be scratched or vandalized.

### GROUT CONCERNS

#### Mosaics

Grout is a mixture of sand, cement, and latex additive. It is permanent and will stay in place for perpetuity if properly cared for by hand washing. Never pressure wash. The following are cost estimates in case of disturbance to grout and tile by vandalism, accidental misuse or extreme weather.

## REPAIR ESTIMATES

Miotto Mosaic Art Studio will provide attic stock of tesserae tiles from surplus left after installation. These tiles can be used if repairs become necessary due to vandalism or other unexpected occurrences. Repair costs are best estimated by providing a per diem rate for labor.

2 artisans x 1 day on site = \$1,700

### Sample Repair Estimates

Replace 10 tesserae; 2 artisans for 1- 2 days, depending on location / vicinity to each other; if tiles are available from attic stock, total costs \$1700.00 - \$2400.00.

Replace 1 Typical Bench Wall Section; as the level of detail is different on each wall and final material has not been chosen, only ROM pricing is available at this time; \$17,000 - \$25,000 total including materials and labor on site.



# Maintenance

## BENCH WALL MOSAIC CONCERNS

It is recommended that the tesserae on the bench background be 90% glass and 10% gold.

As this wall is incorporated into a seating area, it is more likely to be touched than the other elements. The preference for 90% glass smalti is because the color is solid through and a chip in the glass will not be noticeable. The gold tesserae is, however, made up of three layers. If it is chipped, it is possible that only the green base layer will remain and stand out.

## CONDITION ASSESSMENT

In addition to standard cleaning as detailed above, UAP recommends a formal condition assessment be carried out to identify any potential defects that have developed on the artwork's surface or structure. See below for examples. UAP's Preservation Department can provide written condition assessment documentation and recommended repair procedures, if needed, for \$2,500.

- CORROSION OR FAILURE AT WELDS

If any corrosion or damage is identified at welded seams, UAP should be contacted to conduct a structural review and determine a treatment plan.

- LOOSENING OR DISENGAGEMENT OF MECHANICAL CONNECTIONS

All exposed hardware and mechanical connections should be inspected and re-tightened if required. If discovered, UAP should be contacted to conduct a structural review and determine any further treatment that may be required.

- DELAMINATION OR CRACKING OF MOSAIC TILES

All mosaic surfaces should be closely examined. If any delamination or cracking of tiles is discovered, UAP should be contacted to conduct a structural review and determine any further treatment that may be required.



# Planned Community Engagement

Washington Street Historical Society sees the al Qalam: Poets in the Park project as an opportunity to engage and educate the public about the Arabic-speaking community on the Lower West Side. We have planned extensive public programming, beginning even before the project is unveiled. In June 2023, we participated in the Lower Manhattan Cultural Council's 2023 River to River Festival, during which we conducted tours of Washington Street and gave poetry readings in Arabic and English, accompanied by the New York Arabic Orchestra. All four tours were sold out and more than one hundred people attended the poetry reading. Once the artwork is installed, we will begin guided tours, poetry readings, and music, both in the park and in the neighborhood. We have had preliminary conversations with the principal of P.S. 150 who has expressed an interest in WSHS working with his older students to introduce them to the Syrian community that settled nearby.

In 2016, the Department of Cultural Affairs' held a competition which mirrored the city's Percent for Art process to select an artist to create a permanent artwork for the park. Additional collaborators included the Mayor's Community Affairs Unit, NYC Parks, WSHS, the Public Design Commission, the Manhattan Borough President's Office, Community Board 1, as well as then Council Member Margaret Chin's office. Voting panelists also included individuals with Hyperallergic, the Guggenheim UBS MAP Global Art Initiative for Middle East & N. Africa, the office of Arabic and Arabic Literature at the University of Pennsylvania, and AE Superlab. In 2017, Sara Ouhammadou was publicly announced as the selected artist. Since that time, Kendal Henry and Alton Murray from the NYC Department of Cultural Affairs have been supportive. On July 18, 2023, the Waterfront, Parks & Cultural Committee of Community Board 1 approved the design as presented.

WSHS has cultivated and maintained close ties with the Arab American community in New York and throughout the country. We have participated in conferences and panels with American and Lebanese universities; several of our Board members are scholars; and academics serve as advisors. Two important exhibitions about the Syrian colony in New York City have taken place in New York, organized by the Museum of the City of New York and the Arab American National Museum in Dearborn, Michigan, respectively, with WSHS serving as adviser to both. New York arts organizations like ArteEast and Alwan for the Arts have collaborated with us on talks and film screenings. We have been featured in Arabic-language television and newspaper articles about the project and about the history of the Syrian colony.

Our web-based app, accessible and free to the public, was released in May of 2023. Bilingual in Arabic and English, it introduces the history of the Syrian community of Washington Street in the form of a tour of the neighborhood. With historic photos, video and audio clips and text, it can be used both on-site and remotely. A second app will use Augmented Reality to illuminate the artwork of Al Qalam: Poets in the Park, with translations, essays about the poets and their literary movement, historic photographs, and recorded poetry readings and music.



# Funding Sources

## BUDGET

Budget allocated for this project is \$900 000 USD.





**Al Qalam: Poets in the Park**  
Elizabeth H. Berger Plaza | Sculpture