



# Right-of-way Green Infrastructure Protection During Construction

---

Updated September 2021

NYC DEP Green Infrastructure Program Overview	<b>3</b>
DOT Stipulations	<b>11</b>
Protection Measures for ROW Green Infrastructure	<b>16</b>
Rain Gardens	<b>18</b>
Infiltration Basins	<b>26</b>
Porous Pavements	<b>28</b>
Summary and Review	<b>36</b>

- As part of efforts to improve water quality in New York City, the New York City Department of Environmental Protection (DEP) is implementing a Green Infrastructure (GI) Program.
- The program includes the construction of GI in the Right-of-Way (ROW) throughout the combined sewer areas of the City.
- The goal of the ROW GI practices is to collect stormwater runoff from the ROW and infiltrate it into existing subsoils.



# Green Infrastructure Program Snapshot

## Green Infrastructure Program Area-wide Construction

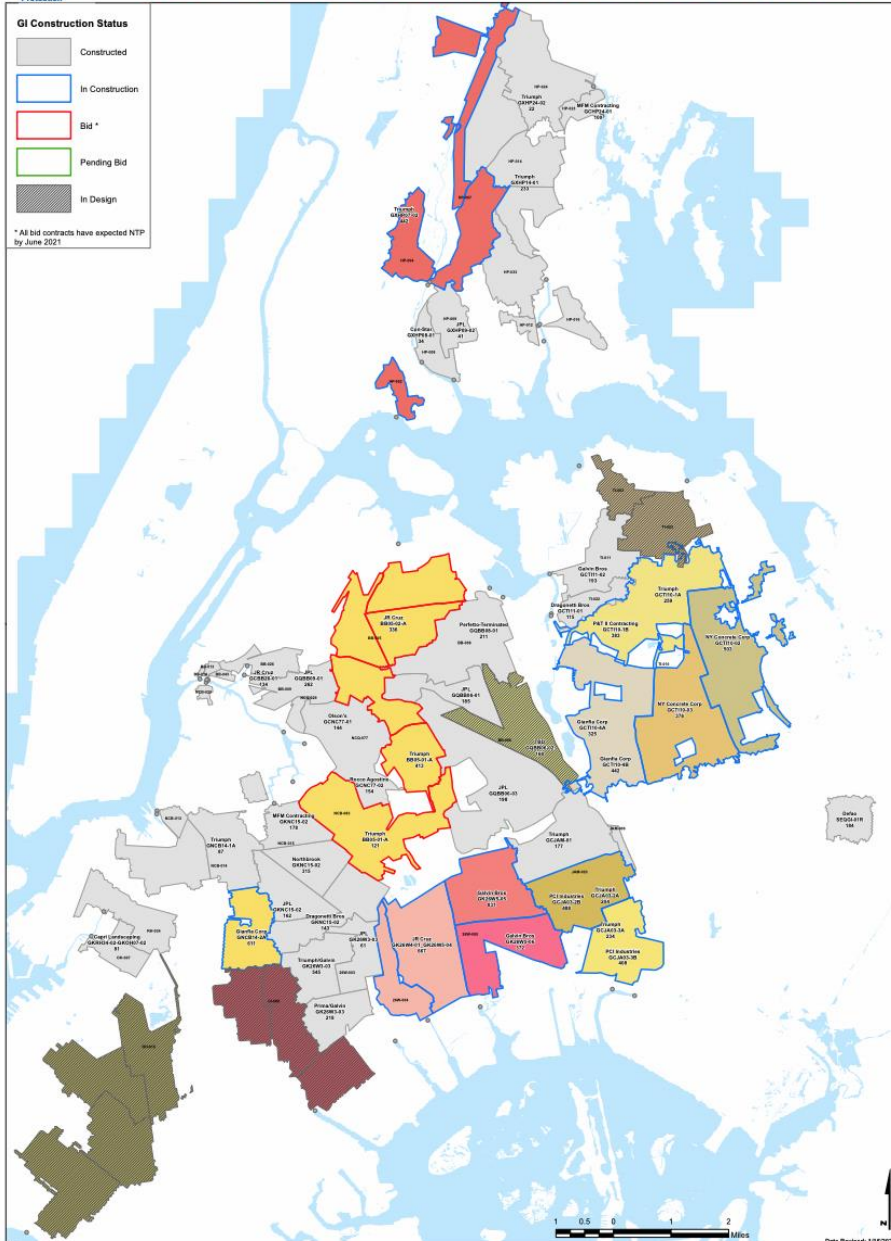

- Over 10,000 ROW green infrastructure practices constructed or in construction

### GI Construction Status

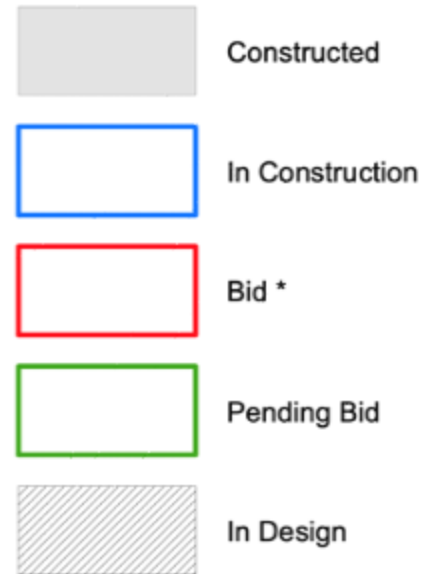

[www.nyc.gov/dep/greeninfrastructure](http://www.nyc.gov/dep/greeninfrastructure)



- Types of Green Infrastructure +
- Private Property Stormwater Incentives +
- Green Infrastructure Reports and Plans +
- Green Infrastructure Standards and Specifications +
- Green Infrastructure Protections +
- Impervious Area Map Layer +



Example rain garden schematic

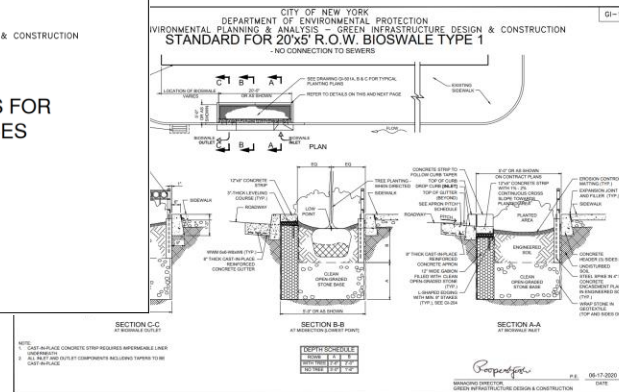

Design Standards

# Purpose of Proper Protections

- Protect hardscape, vegetation, and soil from being damaged, directly or indirectly, by construction debris or physical impacts
- **Prevent construction debris** from entering practice by blocking all openings and setting up fence
- Set up physical barriers to **discourage people, equipment, materials, etc. from entering practice**

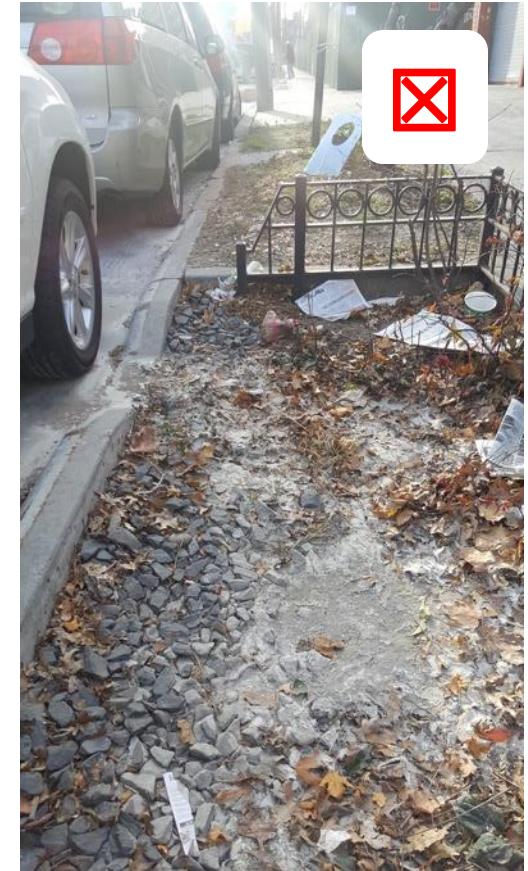

Left: Materials from DPR tree protection causing damage to other vegetation in rain garden  
Right: Concrete runoff entering rain garden due to upstream construction activities and lack of any protections

- Rain gardens
  - Bioswales and Greenstrips with vegetation
  - Bioswales and Greenstrips that are not yet planted
  - Bioswales with stormwater inlet (Type B and Type D)
  - Stormwater Greenstreets
  
- Infiltration Basins
  - Grass Top
  - Concrete Top
  - Combination Grass and Concrete Top
  
- Porous pavements (typically in the parking lane/gutter, entire roadway width in some locations)
  - Precast concrete panels
  - Permeable pavers
  - Porous asphalt

# How to Identify ROW Green Infrastructure

Which of these pictures show ROW Green Infrastructure?





# How to Identify ROW Green Infrastructure

On the surface, ROW Green Infrastructure assets look similar to typical streets and sidewalks.



- Check address/location information on permit
- Confirm exact location on DEP online GI map
- Look for signs of stormwater conveyance
  - Tapered curbs
  - Cuts in the curb
  - Stormwater grates (catch basins)
- Other identifying features
  - Signs with DEP logo
  - RAIN GARDEN decals
  - Pucks on sidewalk



## BIOSW1

- A NYC DEP Right of Way Green Infrastructure practice is located in the roadway and/or sidewalk. Permittee must contact NYC DEP 48 business hours before construction starts at [giutility@dep.nyc.gov](mailto:giutility@dep.nyc.gov) for further instruction on how to proceed. Also, the Permittee must follow NYC DEPs Green infrastructure protection requirements at <https://www1.nyc.gov/site/dep/water/green-infrastructure.page>. Permittee is responsible for restoration, replacement, or reconstruction of damaged DEP Green Infrastructure assets impacted by the Permittee as directed by DEP.

## PERMPV

- NYC DEP Permeable Pavement is located in the roadway and/or sidewalk. Permittee must contact NYC DEP 48 business hours before construction starts at [giutility@dep.nyc.gov](mailto:giutility@dep.nyc.gov) for further instruction on how to proceed. Also, the permittee must follow NYC DEP Green infrastructure a protection requirements available at <https://www1.nyc.gov/site/dep/water/green-infrastructure.page>. Permittee is responsible for restoration, replacement or reconstruction of damaged DEP Green Infrastructure assets impacted by the Permittee as directed by DEP.

- City recently amended provisions in Title 15 Chapter 19 , the purpose of which are to protect the City’s green infrastructure
  - “adding a definition for ‘green infrastructure’ and include it in the definition of ‘sewerage system’ in order to ban the discharge of prohibited substances into such infrastructure, and protect such infrastructure from damage.”
- Effective since March 19<sup>th</sup> 2020
- BEPA intends to enforce aspects of Title 15 Chapter 19 by issuing administrative summonses to violators thereof with civil penalties
  - Discharge of obstructive substance into or other interference to green infrastructure, and discharge of oil into green infrastructure are prohibited

- Follow all GI Protection requirements as listed on DEP webpage
- Notify DEP at [giutility@dep.nyc.gov](mailto:giutility@dep.nyc.gov) at least 48 hours prior to commencing work. Provide the following information:
  - Date and time of planned work
  - Extent of work
  - Type of work
  - Attach the DOT permit
- Take photos of nearby and downstream GI assets before work and after protections are installed
- Install all applicable protection measures and keep in place throughout work

Given enough lead time, DEP staff will be available to provide **on-site guidance** for proper installation of GI protection measures

Good afternoon Matthew,

Based on the information provided there is one (1) bioswale that is in proximity to your construction project and needs to be protected according to the guidelines outlined on our website here:

<https://www1.nyc.gov/assets/dep/downloads/pdf/water/stormwater/green-infrastructure/right-of-way-green-infrastructure-protections-during-construction.pdf>

Please remove any snow that will interfere with installing the protection measures properly and securely.

We request that you provide us with photos of the current bioswale condition and photos of the installed protect measures. Construction should begin after the protection measures are in place. The contractor is liable for any damages to the asset.

Please let us know if you have any further questions.

DEP

## First Section

- States the type and number of GI assets that require protections
- Provides link to the protection guidelines pdf

Good afternoon Matthew,

Based on the information provided there is one (1) bioswale that is in proximity to your construction project and needs to be protected according to the guidelines outlined on our website here:

<https://www1.nyc.gov/assets/dep/downloads/pdf/water/stormwater/green-infrastructure/right-of-way-green-infrastructure-protections-during-construction.pdf>

Please remove any snow that will interfere with installing the protection measures properly and securely.

We request that you provide us with photos of the current bioswale condition and photos of the installed protect measures. Construction should begin after the protection measures are in place. The contractor is liable for any damages to the asset.

Please let us know if you have any further questions.

DEP

## Second Section

- Requests for photos of the current conditions and installed protections

- Site protection fence materials for rain gardens (bioswales, stormwater greenstreets, etc.)
  - Wooden 2x4 members for vertical, horizontal, and cross beams  
(For stormwater greenstreets: use wood or steel stakes instead)
  - Landscape fabric (filters debris but allows air, typically non-woven)
  - Zip ties to attach landscape fabric to wood
- Temporary cover material to protect vegetation during concrete work (less permeable than landscape fabric for rain garden protection fence, e.g., woven geotextile)
- Sandbags to block all curb cuts and grated inlets
- Silt sock for perimeter of rain gardens and/or permeable pavement
- Standard erosion control for catch basins (e.g., inlet filters)
- Safety cones
- Impermeable liner to cover grated openings on ROW Infiltration Basins
- Steel plate for permeable pavement, if using heavy machinery



- All GI practices **must be protected** if construction is being performed close by or upstream to a practice, in order for the GI practices to maintain their function. Install protection measures at **all nearby and downstream GI practices**.
- **Do not stockpile materials** within, around, or on top of any GI practice.
- **Control construction runoff and debris at the source** to the extent possible.
  - **Install control measures around work** producing dust, concrete slurries, or other construction debris. The Contractor must also control dust following DEP, OSHA and any applicable Federal and State regulations.
  - Cover and install erosion control measures for stockpiled materials to prevent particulates from migrating.
- The Contractor must ensure that protection measures **are properly installed, adequately maintained, and are kept in place** throughout all construction activity.
- The Contractor **must keep protective measures in place** until completion of construction activity or DOT Street Opening Permit is no longer required, and **properly remove all protective measures** at the conclusion of construction.
- **The Contractor shall be liable** for damage to ROW GI practices if proper controls are not installed and maintained throughout the construction period.
- The Contractor must **allow DEP personnel to have access** and to perform inspection of the ROW GI practice and GI protections, as necessary.

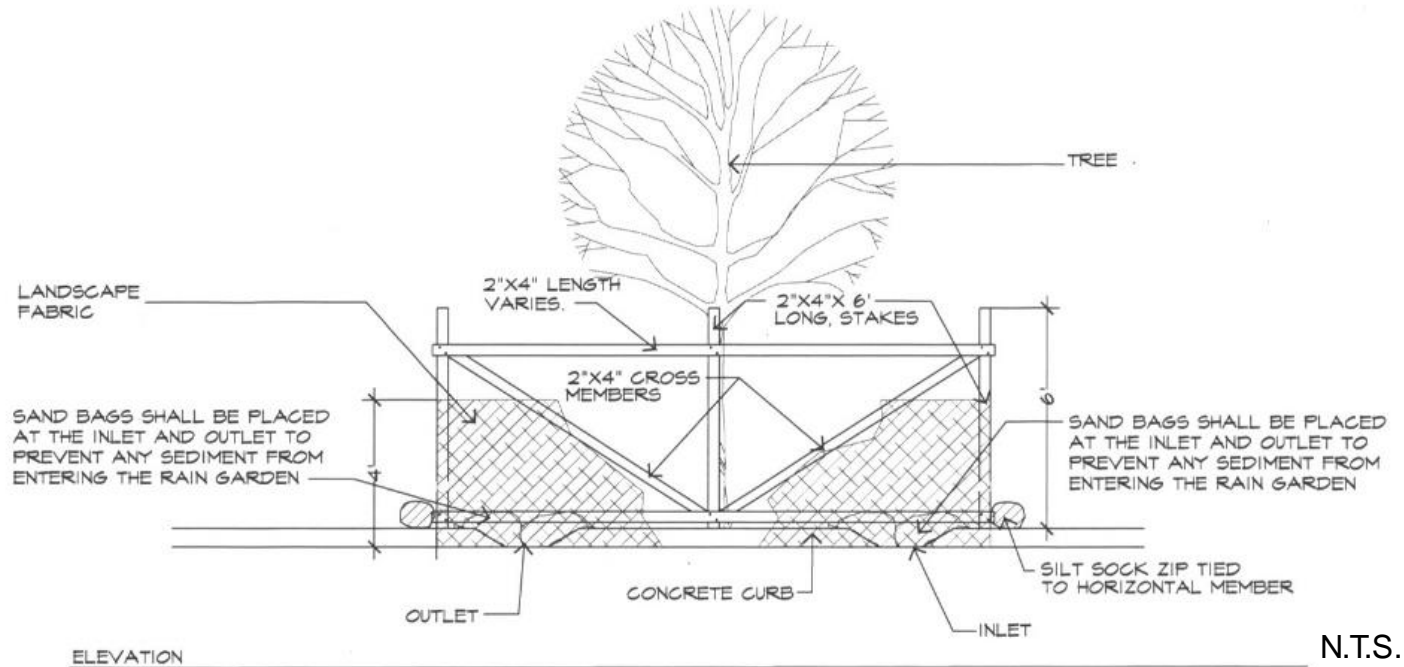

## PROTECTION COMPONENTS

- **Wooden protection** around entire rain garden. Wooden structure must be 6' high and installed outside of the rain garden steel tree guard.
- **Landscape fabric** or geotextile, 3'-4' high, installed flush to ground and attached to wooden members using zip ties on sidewalk side (may be attached with staples on street side)
- **Sandbags** at all curb openings
- **Silt sock** (minimum 6" diameter) on sidewalk, zip-tied to horizontal member around three sides of rain garden



## GI PROTECTION TIP

- Do not step inside rain garden when installing protection measures
- No protection components should be placed in or on top of soil bed – wooden members must rest on sidewalk or top of curb
- Fence can be stabilized by tying to tree guard if necessary
- Ensure sandbags are placed so that they completely block out all runoff from entering rain garden. Use sufficient number of sandbags and place firmly to close the open channel(s).
- Routinely check landscape fabric and sandbags to ensure that they are intact

- **Additional protection requirements** for the following types of work being conducted near or above existing vegetation in rain gardens:
  - Concrete work including, but not limited to :
    - concrete pouring
    - sawcutting
    - concrete demolition
  - Any other dust-producing work
  - Any other spatter-producing work
- Temporary coverings required daily
- Watering as needed per Section GI-4.10(D)(1) of the Standard Green Infrastructure Specs on DDC website ( [https://www1.nyc.gov/assets/ddc/downloads/publications/infrastructure/Green\\_Infra\\_Standard\\_Specs\\_2021\\_Initial\\_Release\\_2021-09-01.pdf](https://www1.nyc.gov/assets/ddc/downloads/publications/infrastructure/Green_Infra_Standard_Specs_2021_Initial_Release_2021-09-01.pdf) )



- Asset Type: Bioswale with tree
- Type of Work: Sidewalk replacement
- Key Take Away:
  - ✓ Use sandbags to protect inlets.
  - ✓ Landscape fabric height should be 4' maximum
  - ✓ Additional protection is needed for dust-producing work.
  - ✓ Notify DEP 48 hours before the start of construction.



- Vegetation within rain garden must be protected with a temporary cover material that is designed to filter out fine particles and is resistant to moisture and biological degradation
  - Typical acceptable material include woven geotextiles with Water Flow Rates (per ASTM D4491) of less than 100 gpm/ft<sup>2</sup>
  - Cover material shall not be kept over vegetation for more than 12 continuous hours



Source:geosolutionsinc.com



## PROTECTION COMPONENTS

- Install **all applicable protection measures for typical rain gardens** including, but not limited to sandbags and temporary fencing
- Install temporary **inlet filter bags** for stormwater conveyance inlets, following methods used to protect Standard DEP Catch Basins.
- Refer to NYC DOT's *Standard Highway Specification Volume II, Appendix F* for material and installation specifications for inlet protection.

## GI PROTECTION TIP

- Check protection measures regularly to ensure that the ROW GI is properly protected
- Check and remove sediment from the inlet filter bag when it becomes full
- Remove all protection measures after construction activities have ceased



## PROTECTION COMPONENTS

- Use same protections as rain gardens with vegetation where feasible. If not, at a minimum:
  - Place **sandbags** at curb cuts
  - Lay **temporary covering** (landscape fabric or plastic) over the bare soil area and gently secure
  - Install **landscape fabric** 2'-3' high around entire rain garden, supported by wooden stakes



## GI PROTECTION TIP

- Avoid stepping onto the soil when placing temporary covering
- Do not stockpile materials inside of rain garden, regardless of whether there is vegetation or not



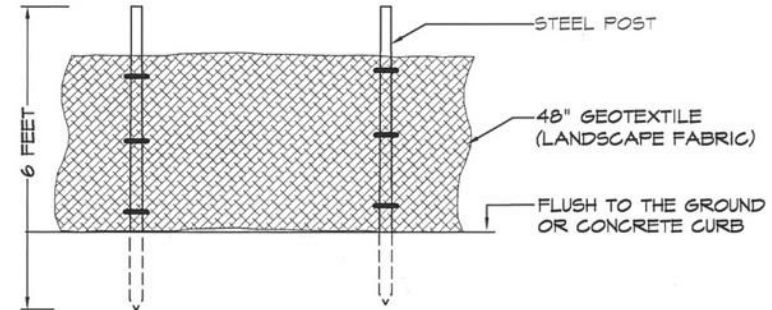

**NOTE:**  
SECURE FENCING TO POST WITH WIRE TOP, MIDDLE, AND BOTTOM OF POST. WIRE SHALL BE TIGHT ENOUGH TO PREVENT THE FENCING FROM SLIPPING DOWN.

## PROTECTION COMPONENTS

- Install site protection fence using 6' **steel or wood posts** and **landscape fabric** around entire perimeter of planted area
- Close off all curb openings with **sandbags**
- Trees within Stormwater Greenstreets will require DPR standard protection for street trees

## GI PROTECTION TIP

- Avoid impacting existing vegetation when installing fence and/or placing DPR tree protection
- Do not step inside or place materials within Stormwater Greenstreet
- Confirm protections are intact throughout construction activities

# Right-of-way (ROW) Infiltration Basins

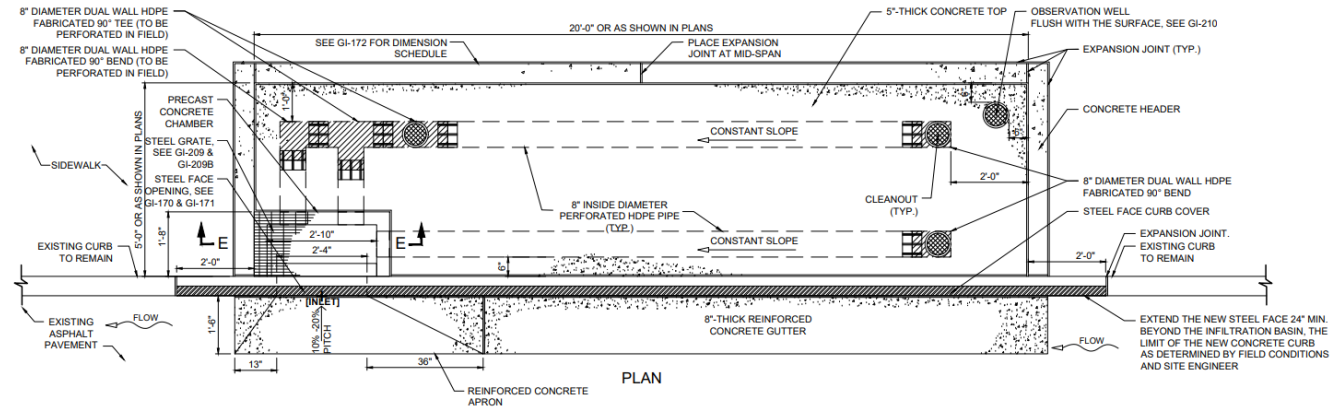

Key features: clean-out covers, concrete headers, NYC DEP logo on grates (at some locations), openings in the curb, concrete apron in roadway gutter



Left: Infiltration Basin with Concrete Top  
Right: Infiltration Basin with Grass Top





## PROTECTION COMPONENTS

- Install **sand bags** at curb cuts along the gutter line
- Cover or **close grate openings** (e.g. plywood, rigid plastic board, proprietary filtering system). Secure material as appropriate.

## GI PROTECTION TIP

- Place safety cones wherever there may be a tripping hazard on the sidewalk
- Do not stockpile materials on top of GI practice
- Check protection measures regularly to ensure that the ROW GI is properly protected. Repair or replace GI protection as needed



# ROW Porous Asphalt

## Porous Asphalt along parking lanes only & full roadway width

Location: 4 street segments in Maspeth (Queens)

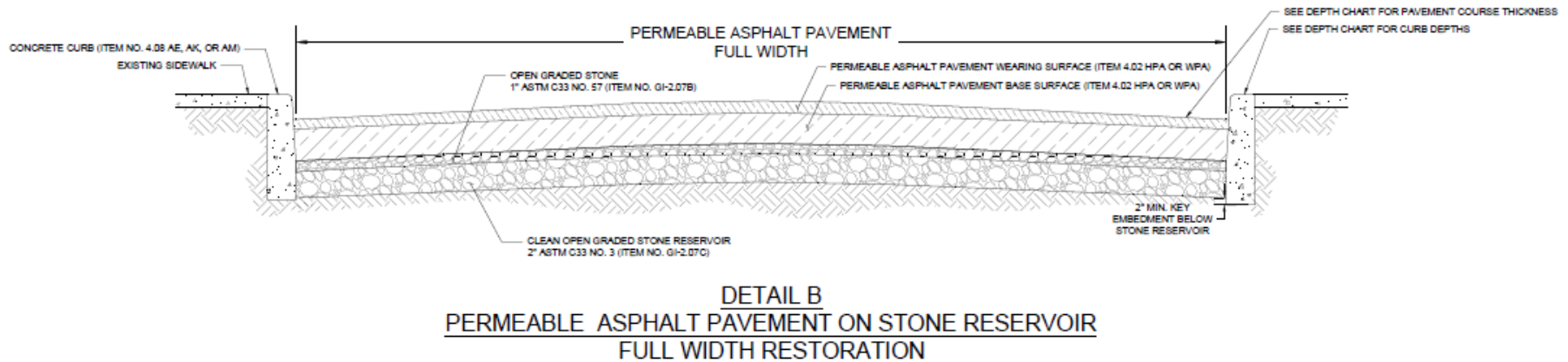
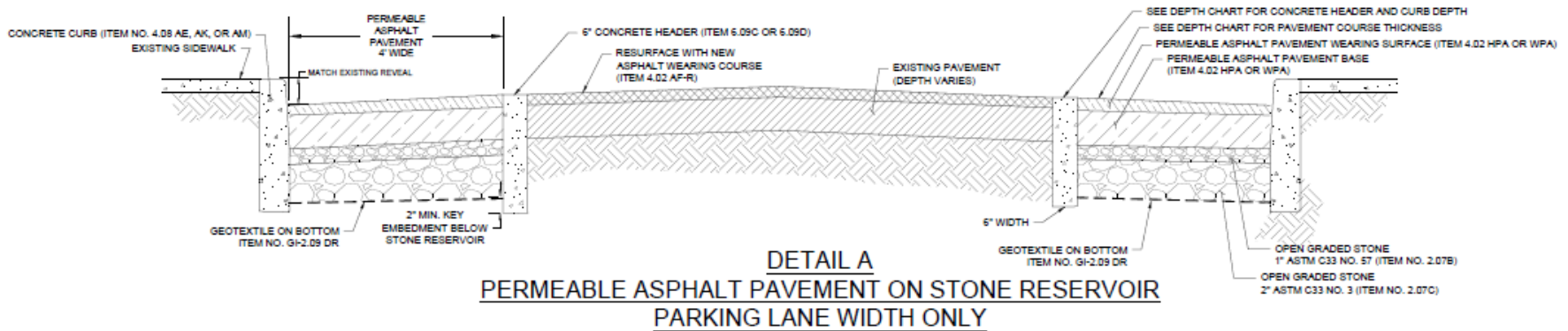

## Permeable Pavers and Porous Concrete Panels along the parking lane

Locations: Wakefield (Bronx), Rego Park (Queens), Ozone Park (Queens)

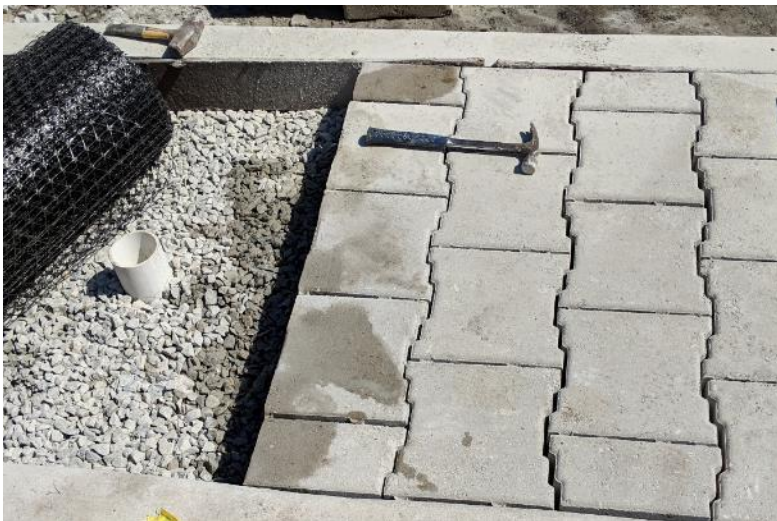
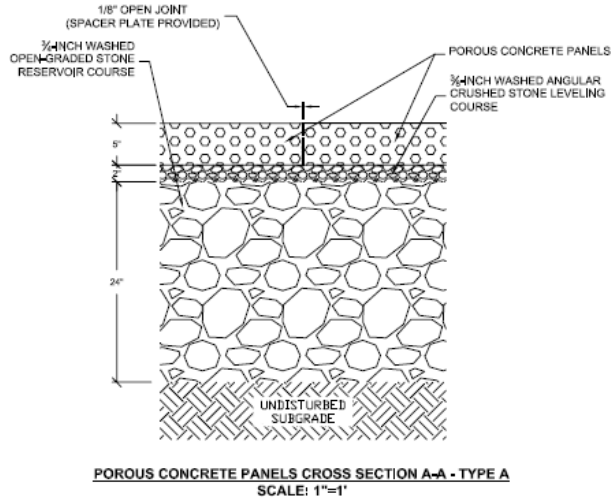

- Porous panels
- Concrete casing which contains utility valves.
- Road asphalt is separated from the pavers by concrete headers
- Permeable Structure is not connected to the catch basin



- Install sediment and erosion control:
  - Where possible, implement sediment control at the source
  - Place silt socks or other methods around the permeable pavement to divert sediment away
  - Use temporary cover over entire permeable surface

## PROTECTION COMPONENTS

- Utilize **silt sock** around segments of permeable pavement that are nearby and/or downstream
- Install **temporary covering** over entire permeable surface and secure in place.
- No heavy machinery. If unavoidable, use **steel plates**.

## GI PROTECTION TIP

- Check to make sure protection measures remain in place and are functioning as intended.
- Assess vehicular access considerations for permeable pavement in front of driveways
- Place steel plates gently and do not drag across pavement surface





- Contractor must restore permeable surface material AND underlying layers (open graded stone and choker course or geotextile) at the end of construction
- Removing *precast porous concrete slabs*:
  - In general, if slabs are removed correctly, they can be reused and reinstalled after completion of work.
  - Most slabs have cast-in ½” lifting inserts (typically four locations for 5’ x 4’ slabs and two locations for smaller slabs). Use equipment that can lift the slab vertically and not on an angle.
  - Only where necessary, slabs should be cut at joints.
  - In no case shall partially supported slabs remain in place during duration of the work.
- Removing *permeable pavers*: can also be reused if removed and handled carefully (e.g., by hand)





## Concrete Apron and Gutter

- The apron and gutter are used to maintain a steady flow into and out of the practice

### Steps:

- Use white spray paint to identify practice limits
- From the outside header place a white line leading from the sidewalk to the road.
- The paint marks be spaced 1' apart with the center called out with a dot.

## GI PROTECTION TIP

- Paint lines should be perpendicular to the curb

- Markings should be placed on both sides of the practice.
- Once the edge of the curb is marked, sawcut between the asphalt and concrete gutter to separate the materials.



- This allows for milling operator to reposition the machine around street components and to remove the asphalt while leaving the concrete.
- This process can be done without chipping or cracking the concrete elements.



- Increased pedestrian ramp construction
- Rain garden locations are upstream and in close proximity to street corners
- Protect the inlets with sandbags
- Cover bare soil with geotextile fabric



- Installing protection measures is easier than repairing damage. In many cases, damage cannot be “undone” and requires completely rebuilding the asset
- Improper protections can cause as much damage as no protection
- The Contractor shall be liable for damage to ROW GI practices if proper protections are not followed, installed, and maintained
- Consider what plants need for survival
  - sunlight
  - clean water
  - stable soil

Protection Requirements for  
Right-of-Way

## Green Infrastructure

(Rain Gardens, Infiltration Basin, and Permeable Pavements)



Utility Coordination:  
[giutility@dep.nyc.gov](mailto:giutility@dep.nyc.gov)

Additional Information:  
[nyc.gov/dep/greeninfrastructure](https://nyc.gov/dep/greeninfrastructure)

General GI Inquiries:  
[RainGardens@dep.nyc.gov](mailto:RainGardens@dep.nyc.gov) or  
718-595-7599