



2016 CRANE TECHNICAL WORKING GROUP REPORT

CRANE TECHNICAL WORKING GROUP REPORT

Contents

INTRODUCTION	3
EXECUTIVE SUMMARY	3
1.0 ACCIDENT SUMMARY	12
2.0 CRANE SAFETY TECHNICAL WORKING GROUP	12
2.1 Working group membership.....	12
2.2 Public and industry input.....	13
2.3 Working Group review.....	13
3.0 CRANE OVERVIEW	14
3.1 Mobile cranes.....	14
3.2 Tower cranes.....	18
3.3 Crane jobsite use and personnel.....	20
3.3.1 Assembly/disassembly phase	20
3.3.2 Operational phase.....	24
4.0 NEW YORK CITY CRANE REGULATIONS AND ENFORCEMENT SCHEME	26
4.1 Summary of New York City crane regulations.....	26
4.2 Exemptions from New York City crane regulations.....	30
4.3 Enforcement of city regulations.....	30
4.3.1 Plan Examination.....	30
4.3.2 Inspection.....	32
4.4 New York City crane activity.....	32
4.5 Historical New York City crane incidents.....	33
4.6 New York City Department of Transportation.....	37
4.7 FDNY and OEM.....	38
4.8 High Risk Construction Oversight (HRCO) study.....	38
4.9 Ongoing Department rulemaking surrounding cranes.....	38
4.10 Commissioner’s Order.....	39

5.0 NATIONAL AND INTERNATIONAL CRANE REGULATIONS	40
5.1 <i>Crane regulations across the United States</i>	40
5.2 <i>Model standards for cranes</i>	41
5.3 <i>International crane regulations</i>	42
5.4 <i>United States Navy crane regulations</i>	43
6.0 TRANSPORTATION INDUSTRIES	47
7.0 RECOMMENDATIONS	48

INTRODUCTION

The following is an interim report from the Crane Technical Working Group, which was established by Mayor Bill de Blasio and Buildings Commissioner Rick Chandler following the crane collapse in Tribeca on February 5, 2016. The 23 recommendations contained in this report reflect the Working Group's independent expertise in engineering and government; a thorough assessment of crane regulations in cities around the world that, like New York, have dense urban cores; and input from members of the city's construction industry, who also have a great stake in ensuring that our cranes are the safest in the world.

The investigation of February's accident is ongoing. Investigations of this kind can take many months to complete. Upon the completion of this investigation, the Technical Working Group will issue a final report that may include additional safety recommendations.

EXECUTIVE SUMMARY

In a vertical city, construction requires cranes. New York City's crane regulations are among the most comprehensive in the world. They cover all phases of a crane's lifecycle - from design and manufacturing at the factory; to maintenance, repair, and inspection in the crane yard; to installation and operation at a construction site.

Nevertheless, technology and best practices are continually evolving. Advances in technology have enabled cranes to expand their reach and become increasingly specialized. New York City's crane regulations were last comprehensively revised in 2006; subsequent provisions specific to tower cranes were added in 2008. In 2015, the Department of Buildings launched a new effort to update the city's crane regulations. This ongoing effort, together with the recommendations in this report, represent a unique opportunity to fundamentally improve crane safety in New York City.

This report examines the present state of cranes, the existing New York City regulatory and enforcement framework, national and international crane regulations, and best practices from other jurisdictions and industries. This review identifies areas of existing New York City regulation that can be strengthened. Also identified are areas of regulation or best practices that are not currently accounted for in New York City regulations and that should be implemented.

The Technical Working Group's 23 recommendations include the following provisions:

- That cranes be equipped with anemometers, data-logging devices (“black boxes”), and GPS tracking so that cranes can be more closely monitored;
- Additional industry oversight – both periodically and prior to use each day, similar to how airplanes are readied for flight; and
- That the Department of Buildings return to its previous practice of issuing advisories, rather than cease-operations orders, except in extreme weather events, since:
 - Forecasts are not site specific, and crane operators should not wait for DOB guidance before taking action;
 - Cranes rated for lower wind speeds have already been prohibited from City streets; and
 - The recommendations in this report greatly enhance DOB's ability to monitor compliance with regulations.

When enacted, these recommendations will strengthen the city's already robust regulatory framework by applying emerging best practices with technological tools, crane engineering, and design enhancements, ensuring the operation of cranes in New York City remains the safest in the world.

USING THE LATEST TECHNOLOGY

New York City crane industry operations and oversight have always been paper dependent, creating missed opportunities for recording and reviewing crane activities. The Department's ability to regulate the crane industry, and the industry's ability to mitigate hazards, will be improved by embracing the latest technological innovations.

- 1. Data loggers.** Data loggers, a technological enhancement that records activity over time, should be required. Data recorded by the logger must be made available to the Department at the Department's discretion. The creation of this data and its availability to the Department as well as to the crane owner, operator, and other critical partners in crane operations will provide transparency and accountability in crane operations. Data to be recorded can include the crane configuration, radius of the load, status of limit switches, and operator overrides. A mechanism to record the name and license number of individual operating the crane should also be provided.

- 2. GPS tracking.** Mobile cranes have the ability to relocate around New York City and to other jurisdictions. We recommend making it easier for the Department to know where mobile cranes are operating at all times. A GPS tracking device should be installed on all mobile cranes that are permitted to operate in New York City. Such an enhancement will enable the Department to better route inspectors and conduct real time audits of mobile crane activity in the city.
- 3. Electronic record keeping.** The Department is currently working to digitize its inspection and permitting processes; it is recommended that the Department prioritize this work as it relates to cranes and request that the city provide all appropriate resources to implement this work in a timely fashion. This will allow the Department to more efficiently process permit applications and track inspection results. In addition, the Department should explore mechanisms that will allow industry to maintain electronic records related to cranes (e.g. manuals, logs, inspection reports) in a manner that can be accessed by the Department upon request. Shifting the crane industry to electronic recordkeeping will make it easier for the Department to receive and review industry records.
- 4. Anemometers.** It is recommended that the Department mandate that cranes operating in New York City be equipped with an anemometer; except where the crane manufacturer otherwise specifies, the anemometer should measure a 3-second wind gust. The anemometer will enable the crane to measure winds at the jobsite. Wind conditions can vary across the city, and may not reflect what is reported by the National Weather Service at its Central Park or airport metrological stations - for example, winds may be calm at a metrological station, but breezy within the canyons of Manhattan; in the inverse, winds may be strong along the waterfront at JFK airport, but a jobsite blocked by buildings may not experience winds. Where the crane is equipped with an anemometer, the reading recorded at the jobsite should take precedence over National Weather Service measurements.
- 5. Pinpoint forecasting.** Forecasts are an important planning tool. Where the forecast indicates winds will exceed the operating threshold for the crane, the crane should be secured in advance. National Weather Service forecasts are issued on a regional level; however, wind conditions can vary across the city. Emerging technology is increasingly able to merge regional forecasts and block by block topology to provide jobsite specific forecasts. It is recommended that the Department mandate that contractors at large jobsites, or where utilizing a crane with a long boom/jib combination, engage a private metrological service to provide pinpoint forecasting.

6. Age limit. [Introductory Number 443 of 2014](#) is currently pending before the New York City Council. It is recommended that this bill be advanced by the City Council. This bill, if adopted, will impose an age limit on cranes operating in New York City. The phasing out of older cranes will facilitate the utilization of cranes with newer technology and safety features.

7. Self-erecting tower cranes. Self-erecting tower cranes represent a new type of technology, which are increasingly utilized in Europe to construct and service low to mid-rise buildings. Despite the similar name, self-erecting tower cranes are not assembled or operated like a traditional high-rise tower crane. Self-erecting tower cranes are driven to the jobsite and can be set up in under an hour by unfolding in a controlled sequence. They provide good reach and lifting capacity while having a small footprint, making them suited to operating within tight spaces. The Department's current crane regulations do not address self-erecting tower cranes. It is recommended that the Department develop a regulatory and licensing system specific to self-erecting tower cranes. This will enable industry to utilize the flexibility and efficiencies offered by self-erecting tower cranes while ensuring safe operation.

ADOPTING MODEL STANDARDS

The American Society of Mechanical Engineers (ASME), a nonprofit professional association of mechanical engineers, publishes a family of model standards (the B30 standards) relating to cranes and rigging. These standards are collaboratively developed and periodically updated by volunteer committees of crane experts operating under procedures developed by ASME and accredited by the American National Standards Institute (ANSI).

8. Model standards for cranes and rigging. It is recommended that the Department adopt relevant ASME standards for cranes and rigging. This will incorporate the latest thinking of the nation's top crane experts directly into the city's regulations. Appropriate modifications should be made to account for the city's characteristics.

GREATER INDUSTRY ACCOUNTABILITY

The Department's Cranes and Derricks Unit has three primary roles - issuing permits, deeming cranes fit to operate, and performing inspections to verify compliance with city regulations. The Department should develop a regulatory framework to shift the responsibility for certain regulatory activities to qualified and monitored private entities. Equally, similar to the site safety model used in high rise construction in New York City, the Department should create private positions within the crane industry to verify compliance with city regulations at

Crane jobs. Once implemented, these recommendations will allow the Department to more efficiently deploy its resources, perform surprise spot checks and audits, and focus on areas of emerging risk or problem actors.

9. Third party crane certifiers for comprehensive inspection. New York City is the only government body that performs an annual comprehensive inspection of a crane and deems it fit to operate. This inspection requires knowledge and expertise specific to the make and model of crane. California, Washington State, New Zealand, and Singapore have developed systems of licensed or accredited certifiers whose responsibility it is to inspect and signoff cranes as fit to operate. Crane certifiers are only authorized to inspect the types of cranes for which they have demonstrated knowledge and experience. The regulatory framework utilized in these other jurisdictions should be studied and used as a potential basis for a system in New York City. Appropriate modifications should be made to account for the city's characteristics.

10. Risk-based plan examination. It is recommended that the Department evaluate the plan exam functions of the Department's Cranes and Derricks Unit utilizing a risk-based model to identify areas of review to best utilize the Department's resources. A system to audit applications or spot check certain topical areas should be developed. This will allow the Department to more efficiently focus its engineering resources.

11. Adjust staffing models to address cyclical work and need for specialized expertise. The Department should explore the possibility of adjusting its staffing model in order to accommodate fluctuating application volumes and the need for more specialized crane expertise. This could include an evaluation of supplementing plan examination and inspection activities with outside review. It might also include contracting with an outside engineering firm or authorizing third party entities who meet criteria established by the Department. For particularly specialized or complex applications, such a system could allow the Department to leverage outside expertise. The volume of crane applications varies over the course of a year - with spikes in the spring and late autumn. Adjusting staffing structures or retaining outside expertise could enable the Department to more efficiently process applications during peak times.

12. Assembly/disassembly supervision. It is recommended that the Department mandate that a specific person be responsible for supervising the assembly or disassembly of a mobile crane. This will ensure a proper chain of command is in place during this work. The individual should possess appropriate training or experience, as determined by the

Department. OSHA has developed the position of assembly/disassembly supervisor. This regulatory framework should be studied and incorporated in New York City's regulations. Appropriate modifications should be made to account for the city's characteristics.

- 13. Post assembly inspection.** It is recommended that the Department mandate that appropriate personnel as defined by the Department, for example, the assembly/disassembly supervisor, crane operator, or professional engineer, inspect the crane after it has been assembled to verify that it has been properly assembled. A record of such inspection must be recorded.

- 14. Lift director.** It is recommended that the Department mandate that a specific person is present at the jobsite full time, charged with supervising the overall activity of the crane and monitoring compliance with city crane regulations; the crane operator would still be responsible for the safe operation of the crane, and the rigger responsible for safe rigging. The American Society of Mechanical Engineers (ASME) B30.5 standard has developed the position of lift director. The United States Navy utilizes a Rigger-in-Charge. The regulatory framework utilized in these other jurisdictions should be studied and used as a basis for a system in New York City. Appropriate modifications should be made to account for the city's characteristics. The duties of the related ASME position of site supervisor and the current New York City position of crane safety coordinator should also be reviewed to determine how they best fit into the framework of a lift director.

- 15. Pre-shift meeting and inspection.** It is recommended that the Department mandate that the crane operator, assembly/disassembly supervisor, lift director, rigging supervisor, and other personnel, as appropriate, meet prior to the start of each shift and review the day's planned activities, pedestrian and traffic controls, weather conditions and forecasts, wind speed thresholds for the crane configuration, sequence to secure the crane if high winds occur, hazards specific to the jobsite or the crane configuration, and any other appropriate items. An inspection of the crane and rigging hardware must also be conducted to verify that they are in a safe condition and in accordance with the approved plans and permits. Meeting attendance, subjects covered, and the results of the inspection must be recorded.

- 16. Monitoring weather conditions during work.** City regulations assign responsibility to the crane operator to monitor wind speed and to stop work

and secure the crane if winds prove unsafe. This responsibility is appropriate and will be aided by the installation of an anemometer on the crane (see recommendation #4). It is recommended that the Department mandate that the lift director (see recommendation #14) periodically monitor forecasts and receive weather advisories (see recommendations #5 and #17), and coordinate with the operator to cease operation and secure the crane if necessary.

17. Department issued advisories in advance of inclement weather.

Contractors should monitor weather conditions at their jobsite (see recommendation #16). The Department should issue weather advisories with the goal of putting contractors on notice of potential conditions. The Department should reserve its authority to issue orders to cease operation only in anticipation of extreme weather (e.g. a blizzard, tropical system, or similar extreme weather).

18. Post-shift check. It is recommended that the Department mandate that the crane operator and lift director, at the end of each shift, review the latest forecast and verify and record that the crane has been properly secured for forecasted overnight or weekend conditions.

19. Clearly indicate wind speed thresholds and securing sequence. It is recommended that the Department mandate that the wind speed threshold for the crane configuration, as well as the sequence to secure the crane in anticipation of high winds, be submitted to the Department as part of the Certificate of On-Site Inspection (CN) application. Such submittal must be kept in the crane cab for easy access by the crane operator and other appropriate personnel as defined by the Department.

20. Restrictions on cranes with lower wind thresholds. New York City's current regulations set a wind speed operational limit of 30mph. This is an appropriate standard, and should be measured at the jobsite via an anemometer installed on the crane (see recommendation #4). However, a small percentage of cranes with a long boom/jib combination are required by the crane manufacturer to cease operations and be lowered to the ground at a wind speed under 30mph. In the event such a threshold is 20mph or less, it is recommended that the Department codify the safety zone restriction in the Commissioner's Order of March 15, 2016, and restrict these crane configurations to a safety zone that is closed to the public and sufficiently set back from the public, open streets/sidewalks, and occupied buildings. In the event the threshold is above 20mph but below 30mph, the Department should only allow such a configuration if the crane is utilized in such a safety

zone, or if a plan for monitoring and securing the crane is submitted to the city and approved by appropriate city agencies. The plan for monitoring and securing the crane must be site specific, detail the safeguards to be provided for the public and adjoining property, monitoring protocols and thresholds for wind and other conditions, emergency response procedures, and notification requirements to the city.

21. Focused city coordination. The Commissioner’s Order of March 15, 2016, requires contractors to notify the Department of certain crawler crane activities, regardless of the size or location of the crane. Based on this notification, the Department coordinates with the Office of Emergency Management (OEM), which dispatches Fire Department resources as appropriate. The Department should rescind this blanket approach and instead work with the Office of Emergency Management, the Department of Transportation, and the Fire Department to develop tailored notification and response protocols focused on cranes that meet certain thresholds established by the Department (e.g. size of the crane, location in high traffic areas, cranes that have a low wind speed operational limit, or in anticipation of a blizzard, tropical system, or similar extreme weather). This will enable the city to focus resources on cranes and scenarios that will benefit from an enhanced level of coordination with government agencies.

TRAINING AND LICENSING ENHANCEMENTS

To operate a crane in New York City, one must possess a Hoisting Machine Operators license (HMO). The city’s current licensing framework is a combination of two systems grafted on top of one another. The older system, dating to the 1960s, is divided into three classes – A, B, and C. Depending on the class, operators are allowed to operate cranes (of any type) with a certain capacity and boom length. The newer system, implemented in the late 2000s, incorporates an OSHA mandate for crane operators to be certified as to the type of equipment (e.g. tower crane vs. crawler crane). The following recommendations are aimed at providing more specific training.

22. Orientation for cranes with a long boom/jib configuration. Prior to the operation of a crane with a long boom/jib combination, it is recommended that the Department mandate that the operator, assembly/disassembly supervisor, and lift director complete an orientation process specific to the crane configuration. The orientation should be provided by appropriate entities, as determined by the Department, prior to the use of the crane. Appropriate entities could include the crane owner or crane manufacturer. A record of the orientation must be kept at the jobsite and provided to the Department upon request.

23. Create specific licensing endorsement for cranes with a long boom/jib configuration. HMO A and C Class operators are restricted to operating cranes with a boom/jib of 200 feet or less in length. HMO Class B operators are unrestricted. These thresholds were established in the 1960s; however, in the decades since, technology has enabled cranes to reach greater distances. Class B HMOs should be restricted from operating cranes with a long boom/jib configuration, as determined by the Department, unless they hold a specific licensing endorsement for such a crane. The Department should determine the appropriate mechanism to earn the endorsement - training, hands on experience, simulator experience, examination, or some combination thereof.

1.0 ACCIDENT SUMMARY

On February 5, 2016, a Liebherr LR1300 crawler crane collapsed at 60 Worth Street, Manhattan (“the accident”). The accident killed one member of the public and seriously injured another. At the time of the accident, the crawler crane was set up to install a new generator and cooling tower onto a building at 60 Hudson Street, Manhattan.

The cause of the accident remains under investigation.

2.0 CRANE TECHNICAL WORKING GROUP

On February 24, 2016, Mayor Bill de Blasio and Commissioner Rick Chandler established the Crane Safety Technical Working Group (“working group”). The working group was charged to “review and recommend new City policies to improve crane safety” and “evaluate the circumstances surrounding the (accident) and propose additional best practices and regulations to make cranes operating in New York City the safest in the world.”¹ The working group was tasked to report its findings and recommendations within 90 days.

2.1 Working Group Membership

The members of the working group are:

- **Mary C. Boyce**, Dean of Engineering at The Fu Foundation School of Engineering and Applied Science at Columbia University
- **Wayne A. Crew**, General Secretary of the National Academy of Construction
- **Bill Goldstein**, who most recently served as Senior Advisor to the Mayor for Recovery, Resiliency, and Infrastructure
- **Peter J. Madonia**, Chief Operating Officer of the Rockefeller Foundation
- **Katepalli R. Sreenivasan**, President of NYU Polytechnic School of Engineering and Dean of Engineering at New York University

¹ Press release, February 24, 2016. [Mayor de Blasio's Buildings Crane Technical Working Group](#)

2.2 Public and industry Input

The working group solicited comments from the construction industry and members of the public. The working group also held a meeting with the city's existing Crane Rule Advisory Committee ("the advisory committee") on April 25, 2016.

2.3 Working Group review

As the cause of the accident remains under investigation, the working group is unable to "evaluate the circumstances surrounding" the accident, and this report does not specifically address the accident.

In order to "review and recommend new City policies to improve crane safety" and "propose additional best practices and regulations to make cranes operating in New York City the safest in the world", the working group has completed the following:

- A study of cranes generally;
- A review of New York City's current regulations and enforcement scheme;
- A review of national and international crane regulations;
- A review of best practices from the transportation industry; and
- Met with stakeholders of the crane and construction industries.

New York City's crane regulations are among the most comprehensive in the world. They cover all phases of a crane's lifecycle – from its design and manufacturing at the factory, to its maintenance, repair, and inspection in the crane yard, to its installation and operation at a jobsite in New York City.

Nevertheless, technology and best practices are continually evolving. Advances in technology have enabled cranes to expand their reach and become increasingly specialized. New York City's crane regulations were last comprehensively revised in 2006; subsequent provisions specific to tower cranes were added in 2008. In 2015, the Department launched a new effort to comprehensively revise the city's crane regulations. This ongoing effort, together with the Technical Working Group's recommendations, represents a unique opportunity to fundamentally improve crane safety in New York City.

Based on our review of the Department's crane regulations and enforcement scheme, national and international crane regulations, best practices from the transportation industry, and comments received from the public and industry stakeholders, the working group offers 23 recommendations divided into 4 topical areas. These recommendations reflect regulations or best practices that are currently not accounted for in New York City, as well as enhancements that can be made to the city's already robust regulatory framework.

We recommend that the Department work through its existing crane rule advisory committee to develop specific text to adopt these recommendations via rule or legislation. The Department should supplement this work via the issuance of Commissioners Orders and providing training to the industry, as necessary.

When enacted, these recommendations will strengthen the city's already robust regulatory framework by applying emerging best practice with technological tools, crane engineering, and design enhancements, ensuring the operation of cranes in New York City are the safest in the world.

3.0 CRANE OVERVIEW

Cranes utilized in the New York City construction industry are broadly divided into two types - mobile cranes and tower cranes. New York City also regulates other types of hoisting machines, including derricks, material hoists, personnel hoists, and pile drivers; these are beyond the scope of this report. The type of equipment utilized is a choice made by the contractor performing the work dependent upon job-specific needs.

3.1 Mobile cranes

Mobile cranes are self-propelled and capable of travel. They are divided into three general categories:

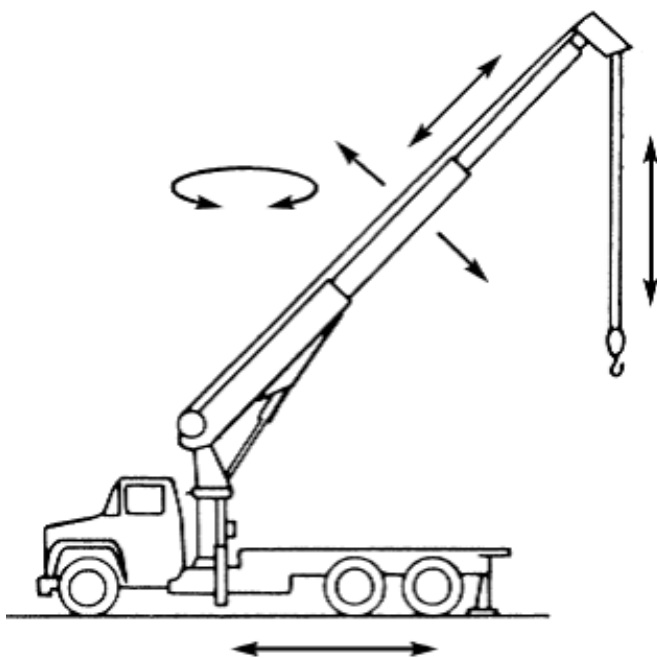

Figure 1: Truck mounted crane

A mobile crane in which the boom is attached to a commercial truck chassis equipped with wheels for travel.

Image: ASME

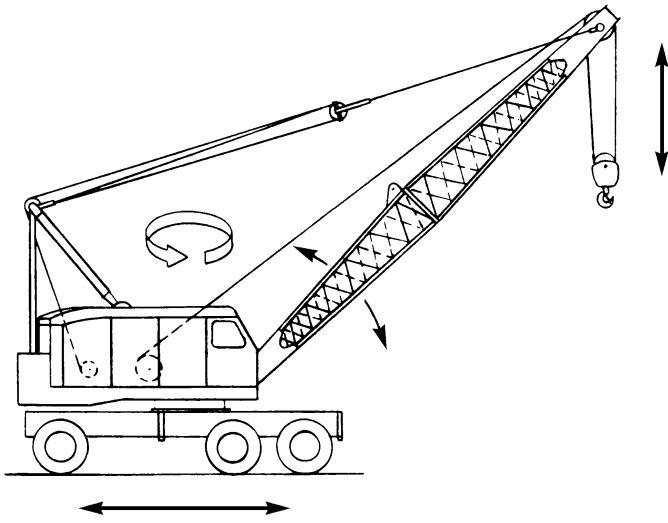

Figure 2: Wheel mounted crane

A mobile crane in which the boom and operating machinery is located on rotating a superstructure that is mounted on a crane carrier equipped with wheels for travel.

Image: ASME

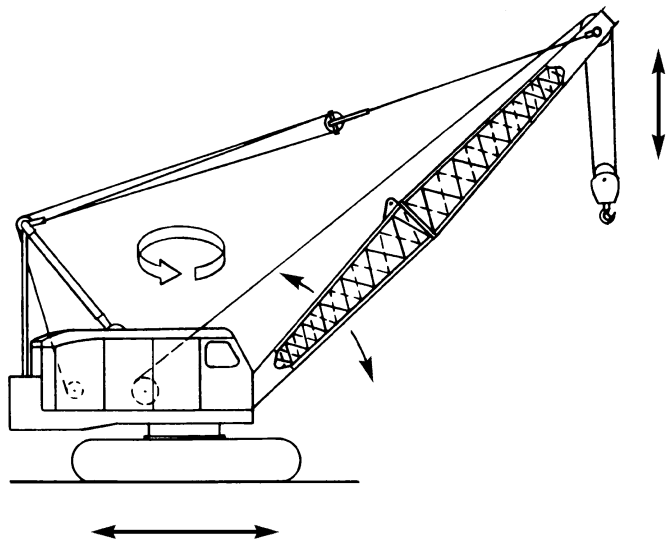

Figure 3: Crawler crane

A mobile crane in which the crane machinery is mounted on a base equipped with crawler treads for travel.

Image: ASME

Mobile cranes consist of a series of components; depending on the make and model of crane, these components can be interchangeable. Major components consist of the:

- **Boom** – The main arm of the crane.
- **Jib** – A component that can be attached to the end of the boom; extends the height and reach of the crane.
- **Counterweights** – Blocks of steel or concrete located on the crane; the weight counterbalances the weight of the item being lifted and prevents the crane from overturning.
- **Boom guy lines** – Cables that provide extra support to the boom.
- **Hoist line** – The main cable of the crane; used to lift and lower a load.
- **Hook** – Located at the end of the hoist line; loads are rigged and attached to the hook.
- **Operator's cab** – Where the operator sits; contains the controls and displays for the crane.

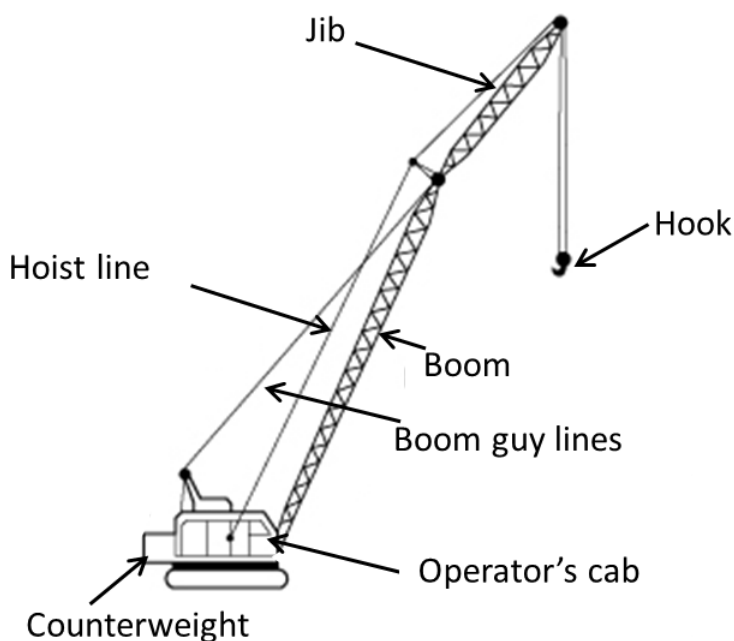

Figure 4: Major components of a mobile crane

Image: ASME

Mobile cranes are also referenced based on the type of boom they utilize :

- **Telescoping Boom** – A boom comprised of a series of concentric tubular parts that can extend or retract. An example is shown in Figure 1 .
- **Lattice boom** – A boom comprised of metal elements crossed and fastened together into square or diamond-shapes. An example is shown in Figures 2 and 3.
- **Articulating boom** – A boom comprised of a series of folding, pin connected structural members. An example is shown in Figure 5.

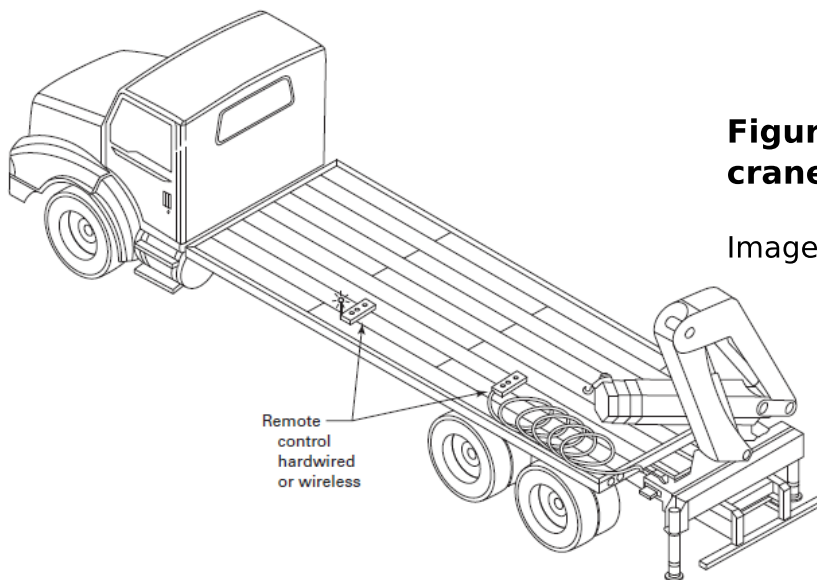

Figure 5: Articulating boom crane

Image: ASME

The type of boom is not dependent on the category of crane – a truck mounted crane, wheel mounted crane, or crawler crane can be outfitted with any type of boom. Jibs are always of the lattice type.

Mobile cranes are versatile and can be used for a variety of projects – from constructing a new building to replacing heating and cooling equipment on the roof of an existing building. The type of mobile crane utilized is dependent upon the reach and height required, as well as the weight of the object to be lifted. Truck mounted cranes generally have the smallest reach, height, and lifting capacity; crawler cranes have the largest. Wheel mounted cranes tend to be in-between. Ease of setup is also a consideration. Truck mounted cranes can be driven to the jobsite and begin operation within a matter of minutes. Crawler

cranes arrive in pieces and must be assembled at the jobsite, an operation which can take a day or more. Like truck mounted cranes, wheel mounted cranes can be driven to the jobsite; however, if the crane utilizes a lattice boom or jib, these components typically have to be installed on the crane at the jobsite, which can take several hours.

3.2 Tower cranes

Tower cranes are mounted on a mast and fixed in place. They are divided into two general categories:

- **Luffing boom** - A tower crane with a boom that can be raised or lowered
- **Hammerhead** - A tower crane with a horizontal boom equipped with a trolley that can traverse the boom.

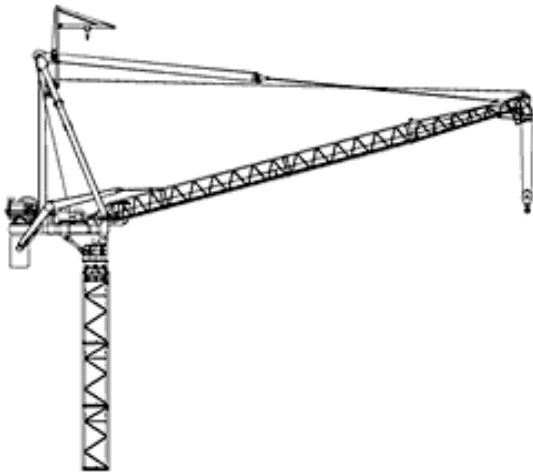

Figure 6: Luffing boom tower crane

Image: ASME

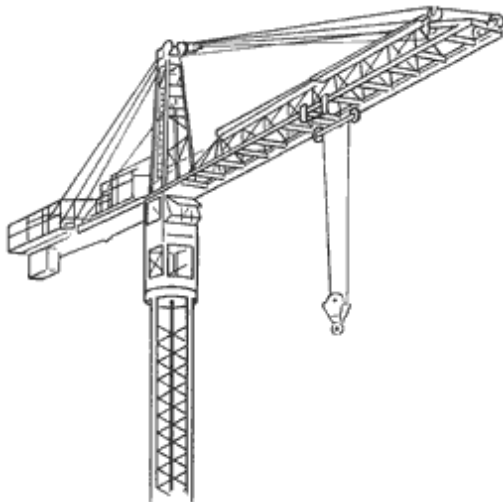

Figure 7: Hammerhead tower crane

Image: ASME

Major components of a tower crane have a similar name and function as their mobile crane counterparts, although tower cranes have noteworthy components, including:

- **Mast** - The tower which supports the crane.
- **Turntable** - The structure on which the upper works of the tower crane pivot; a tower crane is capable of swinging a full 360 degrees.
- **A-frame** - A structure that rises above the tower crane and from which cables are strung to support the boom.

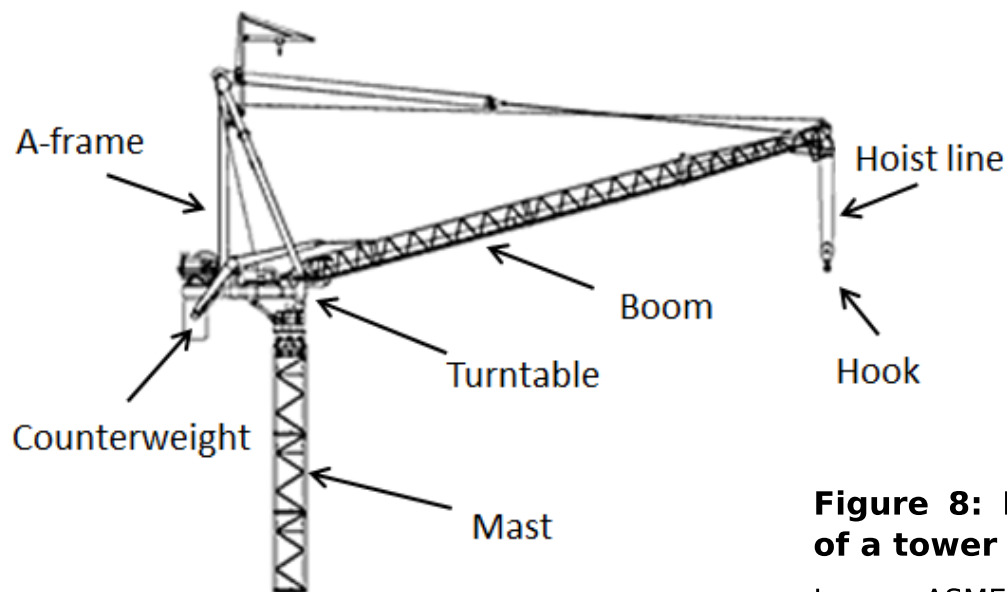

Figure 8: Major components of a tower crane

Image: ASME

Tower cranes are common to high rise construction, and are the only type of crane that can be utilized once the building surpasses a height that can be reached by a mobile crane. In order to support a tower crane, a foundation must be built, and for all but the shortest tower cranes, tie-ins must be added to connect the crane to the building .

The tower crane arrives at the jobsite in a series of pieces, which must be assembled. This process can take days. The components of a tower crane are largely interchangeable.

As the building under construction rises, new mast sections can be added to the tower crane to increase its height, a process known as jumping. A jump can take up to a day.

Separate from the traditional types of tower cranes described above, manufacturers are introducing a new technology - the self-erecting tower crane. Despite the similar name, self-erecting tower cranes are not assembled or operated like a traditional high-rise tower crane. Self-erecting tower cranes are driven to the jobsite and can be set up in a short amount of time by unfolding in a controlled sequence. They provide good reach and lifting capacity while having a small footprint, making them suited to operating within tight spaces. Unlike traditional tower cranes, currently available models of self-erecting tower cranes are limited in height and cannot be jumped to a newer height. Self-erecting tower cranes are not common in the United States, but are increasingly utilized in Europe to construct and service low to mid-rise buildings.

Figure 9: Self-erecting tower crane

Image: ASME

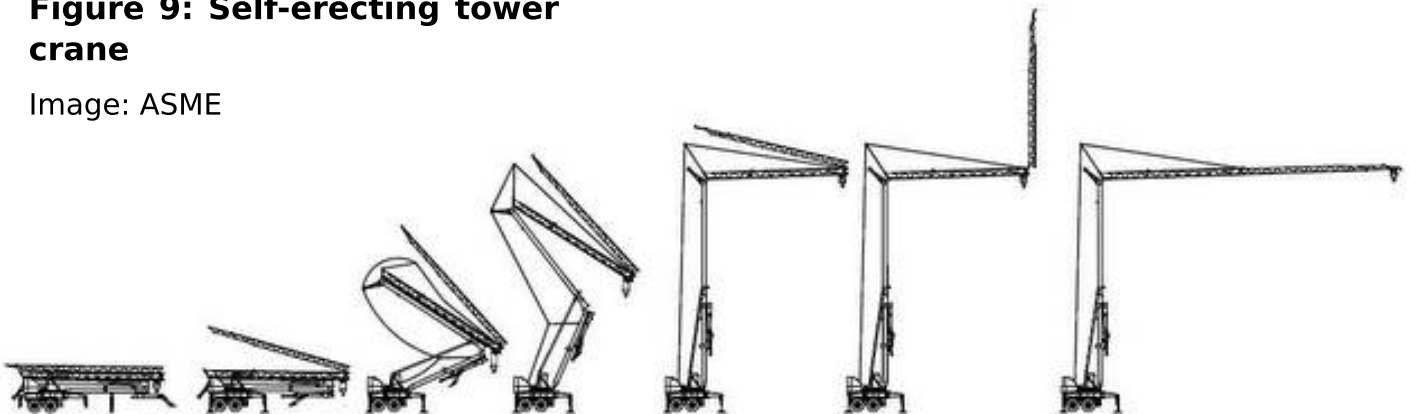

3.3 Crane jobsite use and personnel

The use of a crane at a jobsite is broken into two distinct phases - the assembly/disassembly phase, and the operational phase.

3.3.1 Assembly/disassembly phase

When the crane arrives at the jobsite, it must be prepared for operation. For a tower crane or larger mobile crane, crane components must be assembled together. For a smaller mobile crane, no actual assembly work has to occur;

the crane is simply set up – the operator will position the crane, secure the crane’s outriggers, which stabilize the crane, and begin operation.

At the conclusion of operations, the crane will be removed from the jobsite. For a tower crane or larger mobile crane, the crane components will be disassembled and hauled away. For a smaller mobile crane, the crane operator will simply retract the boom and outriggers, and the crane will be driven away.

Personnel associated with the assembly/disassembly of a crane include:

- **New York State professional engineer** – A New York State licensed professional engineer is required by city regulations to submit plans related to the crane’s assembly and operations at the jobsite. The engineer’s design must be submitted to and approved by the Department.
- **Site supervisor** – The individual who exercises overall planning and coordination of crane activity. This individual, however, does not have to be at the jobsite full time. In New York City, the individual is known as the *Crane Safety Coordinator*.
- **Assembly/disassembly supervisor** – The individual who is responsible for supervising the assembly or disassembly of a crane at a jobsite. For a tower crane, New York City requires this work to be supervised by a licensed rigger. There is no similar position for a mobile crane called out in New York City regulations.
- **Assembly/disassembly crew** – Individuals who assemble/disassemble crane components. This work typically consists of bolting together steel components, prepping cables, and connecting electrical systems and other relays.

ASSEMBLY

New York State Professional Engineer	City regulations require plan submittal related to the assembly and operations at the jobsite; design must be submitted and approved by the Department
Crane Safety Coordinator (Site Supervisor)	Exercises the planning and coordination of crane activity; individual does not have to be at the jobsite full-time
Assembly/Disassembly Supervisor	Supervises the assembly/disassembly of a crane at a jobsite
Assembly/Disassembly Crew	Individuals who assemble/disassemble crane components; consists of bolting together steel components, prepping cables, and connecting electrical systems and other relays

CURRENT STATE

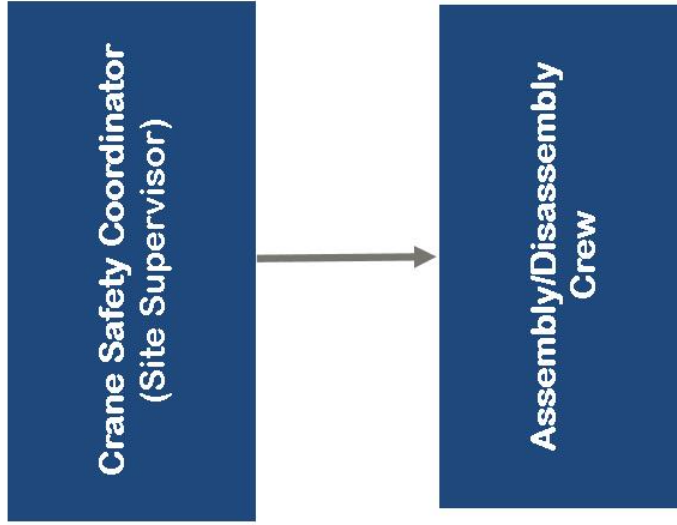

FUTURE STATE

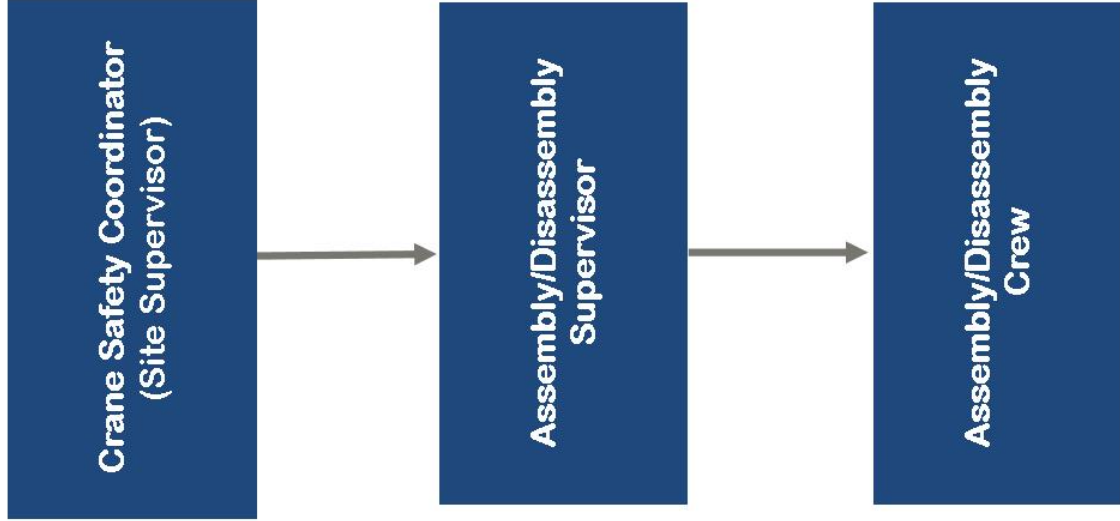

*****NOTE:** Plans must be kept onsite and be made available for these individuals; plans must be followed at all times

DISASSEMBLY

New York State Professional Engineer	City regulations require plan submittal related to the assembly and operations at the jobsite; design must be submitted and approved by the Department
Crane Safety Coordinator (Site Supervisor)	Exercises the planning and coordination of crane activity; individual does not have to be at the jobsite full-time
Assembly/Disassembly Supervisor	Supervises the assembly/disassembly of a crane at a jobsite
Assembly/Disassembly Crew	Individuals who assemble/disassemble crane components; consists of bolting together steel components, prepping cables, and connecting electrical systems and other relays

CURRENT STATE

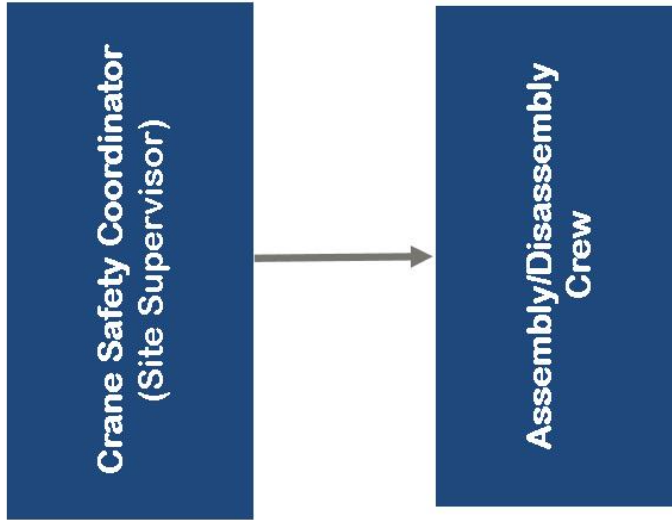

FUTURE STATE

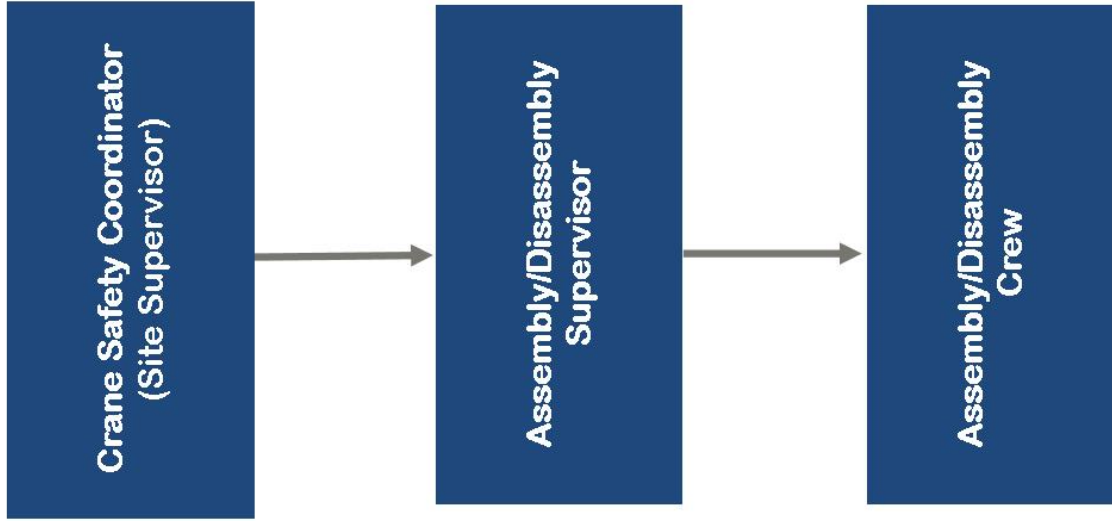

****NOTE: Plans must be kept onsite and be made available for these individuals; plans must be followed at all times*

3.3.2 Operational phase

The operational phase covers the entire life cycle of the crane at the jobsite between the time it has been assembled and until it leaves the jobsite. This includes times the crane is actively being utilized to lift or lower loads, as well as times (typically overnight) that the crane has been shut down and secured.

Personnel associated with the assembly/disassembly of a crane include:

- **New York State professional engineer** - A New York State licensed professional engineer is required by city regulations to submit plans related to the crane's assembly and operations at the jobsite. The engineer's design must be submitted to and approved by the Department.
- **Site supervisor** - The individual who exercises overall planning and coordination of crane activity. This individual, however, does not have to be at the jobsite full time. In New York City, the individual is known as the *Crane Safety Coordinator*.
- **Lift director** - The individual who oversees crane activity at the jobsite. The position of lift director and its entailed duties are spelled out in national model standards. While the duties of the lift director are today generally assigned in New York City to the contractor utilizing the crane, city regulations do not identify a specific individual responsible for performing the duties.
- **Crane operator** - The individual who physically controls the operation of the crane; the crane operator is required to possess a Hoisting Machine Operator (HMO) license issued by the city.
- **Rigging Supervisor** - The individual who supervises the preparation and attachment/detachment of loads from the hook of the crane. New York City requires certain work to be overseen by a rigger licensed by the city; for example, the hoisting or lowering of a boiler or tank. In all other cases, city regulations require the rigging supervisor to have completed a Department approved training course, or hold a Department recognized rigging certification.
- **Rigging Crew** - Individuals who prepare, attach, and detach loads from the hook of the crane. Where a licensed rigger is required, these individuals must be employed by the licensee. In all other cases, city regulations require the members of the rigging crew to have completed a Departmental approved training course, or hold a Department recognized rigging certification city.
- **Signalpersons** - Individuals who communicate with the crane operator and riggers. They must be employed by a licensed rigger or possess the same training/certification as a member of the rigging crew r (HMO) license issued by the city.

OPERATIONAL

CURRENT STATE

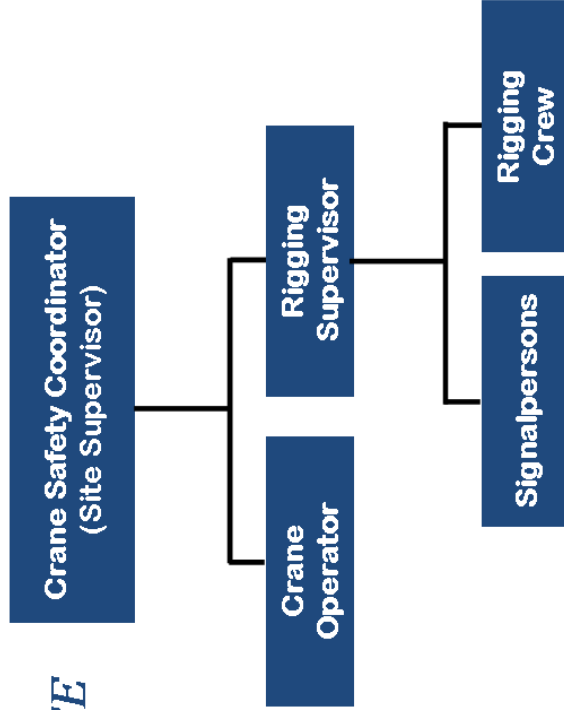

FUTURE STATE

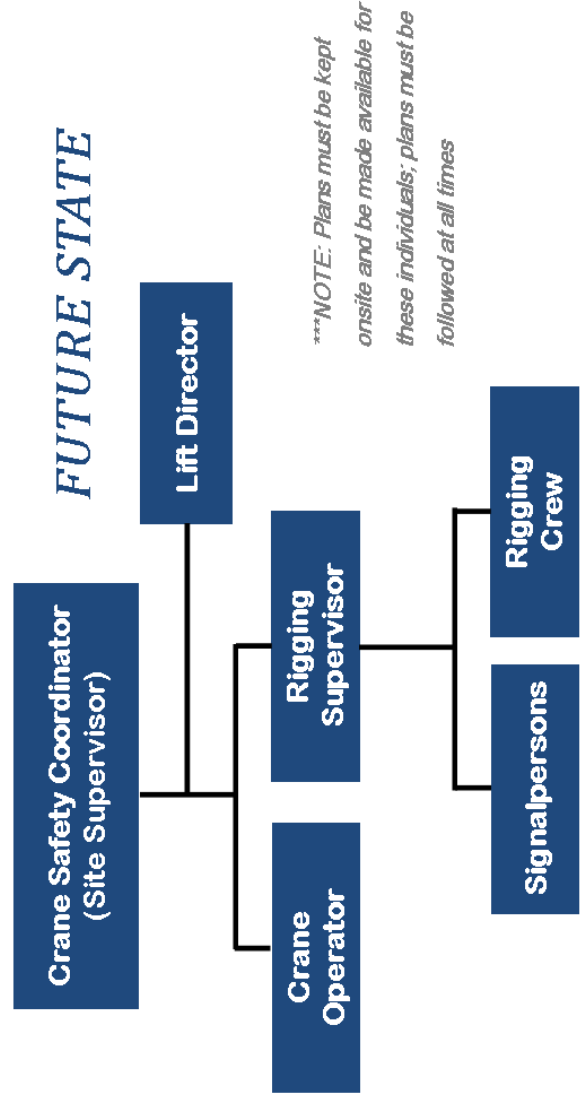

New York State Professional Engineer	City regulations require plan submittal related to the assembly and operations at the jobsite; design must be submitted and approved by the Department
Crane Safety Coordinator (Site Supervisor)	Exercises the planning and coordination of crane activity; individual does not have to be at the jobsite full-time
Lift Director	Oversees crane activity at the jobsite
Crane Operator	Controls the operation of the crane; is licensed by the City
Rigging Supervisor	Supervises the preparation, attachment and detachment of loads from the hook of the crane
Rigging Crew	Prepares, attaches, and detaches loads from the hook of the crane
Signalpersons	Communicates with the Crane Operator and Riggers

4.0 NEW YORK CITY CRANE REGULATIONS AND ENFORCEMENT SCHEME

This section examines New York City's current crane regulations and enforcement scheme. It provides an overview of topical areas regulated by the city, as well as current staffing and inspection levels at the Department related to crane enforcement. It also examines other city agencies that play a role in crane regulation.

4.1 Summary of New York City crane regulations

New York City has in place an extensive body of crane regulations, which are among the most comprehensive in the world. They cover all phases of a crane's lifecycle - from design and manufacturing at the factory; to maintenance, repair, and inspection in the crane yard; to installation and operation at a construction site.

New York City's crane regulations are largely contained in Section 3319 of the New York City Building Code ("BC 3319") and Rule 3319-01 of Title 1 of the Rules of the City of New York ("1 RCNY 3319-01") (formally Reference Standard RS 19-2). BC 3319 establishes the general framework for crane regulation by the Department. 1 RCNY 3319-01 sets forth the specific details concerning crane design, permitting, inspection, operation, maintenance, and repair. Related provisions exist in other sections of law, including Chapter 4 of Title 28 of the New York City Administrative Code and Chapter 100 of Title 1 of the Rules of the City of New York, which establish licensing requirements for hoisting machine operators ("HMO") and riggers, and Section 3316 of the New York City Building Code, which establishes training and supervisory requirements for workers engaged in rigging work. Over the years, the Department has also published Technical and Policy Procedure Notes, Buildings Bulletins, and Service Notices which interpret and clarify city regulations as they relate to cranes.

New York City's crane regulations cover the following topics :

- **Manufacturer requirements.** Crane manufacturers are required by New York City to meet certain baseline requirements, including holding an International Organization for Standardization (ISO) 9001 certification, possessing a 24/7 technical hotline, and having a manufacturer authorized service center, distributor, or authorized service provider located within a four hour travel window of New York City.

- **Make and model design.** Crane makes and models are required to meet design standards recognized by the Department. Currently, the Department recognizes crane design standards published by the American Society of Mechanical Engineers (ASME) and the European Committee for Standardization (EN). These standards provide criteria on loads, overturning stability, wind, and other engineering facets that dictate the design of the crane.
- **Make and model approval.** Before a new make and model of a crane can be introduced to the New York City marketplace, the crane manufacturer or owner must submit to the Department information demonstrating that the make and model meets New York City recognized design standards. This information is reviewed by the Department, and if deemed acceptable, the Department will issue a Certificate of Approval (aka “prototype approval”) for that make and model of crane.
- **Registration of cranes.** Individual cranes manufactured under an approved make and model must be registered with the Department in order to operate in New York City. For a crane to be registered, it must pass a comprehensive inspection (see below). If the crane passes the inspection, it is issued a Certificate of Operation (aka “CD”) by the Department as proof of registration. For a mobile crane that does not require assembly at a jobsite, the CD is valid for one year. For a mobile crane that requires assembly at a jobsite (e.g. a crawler crane) or for a tower crane, the CD is valid only for the duration of the job.
- **Frequent and periodic inspections.** The Department requires crane owners and crane users (the contractor utilizing a crane at a specific jobsite) to inspect the crane on both a frequent (daily to monthly) and a periodic (monthly to annual) basis. The scope and frequency of inspections are specified in Department regulations.
- **Comprehensive inspection.** A Department inspector will inspect the crane and review repair and maintenance records to determine if the crane is well maintained, properly repaired, and fit to operate. For a tower crane, the crane must also pass an inspection and a review of repair and maintenance records conducted by a third party licensed New York State professional engineer. In New York City, the comprehensive inspection is required in order to register the crane and receive a Certificate of Operation (CD).
- **Maintenance and repair requirements.** City regulations establish maintenance and repair criteria for cranes that operate in New York City.

- **Approval of repairs.** Structural repairs made to a crane registered with the Department must be approved by the Department. Once a structural repair is needed, the crane cannot operate in New York City until the Department has approved the repair.
- **Jobsite specific design.** Before a crane can be utilized at a specific jobsite, a New York State licensed professional engineer must develop plans. These plans indicate the proposed location and configuration of the crane, and demonstrate that the crane will be stable and able to clear all obstructions. The plans also detail any support or reinforcement required to the ground or to a building to support loads imposed by the crane. Where the crane attaches to a building or structure, details of these connections are also shown on the plans.
- **Jobsite specific permit.** Jobsite specific design plans (see above) must be submitted to the Department for review and approval. After the plans are approved, the crane can be installed at the jobsite. Upon an inspection that the crane has been installed according to plan (see below), the Department issues a Certificate of On-Site Inspection (aka "CN"), which authorizes the crane to operate at the specific jobsite.
- **Inspection to verify compliance with jobsite permit.** The inspection to verify the crane has been installed according to plan is conducted by a Department inspector; except that a mobile crane that has a boom of 250 feet or less is inspected by the engineer who developed the plans.
- **Comprehensive inspection.** A Department inspector will inspect the crane and review repair and maintenance records to determine if the crane is well maintained, properly repaired, and fit to operate. For a tower crane, the crane must also pass an inspection and a review of repair and maintenance records conducted by a third party licensed New York State professional engineer. In New York City, the comprehensive inspection is required in order to register the crane and receive a Certificate of Operation (CD).
- **Licensing of crane operators.** The Department licenses crane operators through the issuance of Hoisting Machine Operator ("HMO") licenses. Licenses are divided into three classes - A, B, and C. The class C license authorizes the operation of wheel mounted cranes and boom truck cranes (subsets of mobile cranes) that have a capacity of 50 tons or less and a boom of 200 feet or less. The Class A license authorizes the operation of any crane (mobile or tower) with a boom of 200 feet or less. The Class B license is an unlimited license that allows the operation of any type of hoisting machine. To obtain a license, an individual must obtain a prerequisite number of years of experience as a trainee under the

supervision of a licensed HMO (the amount varies depending on the type of license), pass a medical physical and a substance abuse test, complete a 40 hour course focused on New York City crane regulation, and hold a national certification for crane operation. The national certification further constrains the HMO as to the type of crane they can operate. National certifications test to specific types of cranes (e.g. lattice boom crawler crane, telescoping boom truck, tower crane, articulating boom crane, etc.); so for example, if a Class A HMO only possesses a national certification for a lattice boom crawler crane, he or she may only operate a lattice boom crawler crane with a boom of 200 feet or less and not, for example, a tower crane. Individuals may possess multiple national certifications. The Department tracks all of this information, including the specific types of cranes the operator is certified for.

- **Safety devices and operational aids.** City regulations mandate that cranes be equipped with certain safety devices and operational aids. For example, alarms that warn an operator when the crane is nearing an operational limit, and automatic shutdowns that stop a crane once it reaches an operational limit.
- **Operating procedures.** City regulations specify procedures to ensure the safe operation of the crane. For example, prohibiting the lifting of loads over people, or over occupied buildings unless the top two floors of the building are vacated; procedures for when operating near power lines; and procedures for hoisting, holding, and moving loads.
- **Rigging standards.** City regulations also address rigging operations – that is, how to prepare and attach loads to the hook of the crane. Particular attention is given to rigging work related to the erection, jumping, or dismantling of a tower crane. For example, a safety meeting is required prior to such work, and during which rigging (ropes, chains, slings, etc.) to be utilized are reviewed. The use of discarded ropes for slings is prohibited. Synthetic slings can only be utilized for tower crane erection, jumping, or dismantling if the manufacturer allows their use.
- **Licensing of riggers.** The Department licenses riggers and mandates specific types of work to be supervised by a licensed rigger; for example, the erection, jumping, or dismantling of a tower crane, or the hoisting or lowering of a boiler or tank .
- **Training/certification for rigging workers.** For instances where a licensed rigger is not required, city regulations require the workers engaged in the rigging operation to possess a national rigging certification, or to have completed a Department approved rigging training course.

- **Assembly/disassembly supervision.** City regulations require a licensed rigger to supervise the erection, jumping, or dismantling of a tower crane. There is no specific requirement related to the assembly or disassembly of a mobile crane.
- **Jobsite crane supervisor.** In instances where a licensed rigger is required, the licensed rigger, or a foreman designated by the licensee, provides overall jobsite supervision of the crane. In other cases, the contractor using the crane identifies a “crane safety coordinator” who has a general supervisory responsibility for the crane, but is not required to be at the jobsite on a full time basis.

4.2 Exemptions from New York City crane regulations

Not all cranes operating in New York City are subject to the city’s regulations.

Cranes utilized in conjunction with state, bi-state, or federal projects are exempt as of right, although some agencies have voluntarily entered into special agreement with the Department to follow some or all of the city’s crane regulations. Cranes utilized in factories, commercial yards, and maritime facilities are also exempt.

Smaller cranes are also exempt from some or all New York City regulations. For example, mobile cranes with a capacity of 3 tons or less are exempt from city regulations if the boom is 50 feet or less; if the boom is between 50 feet and 135 feet in length, the crane requires a Certificate of Operation, but does not require a Certificate of Approval or a Certificate of On-Site Inspection. Cranes on delivery trucks are exempt from city regulations, as are articulating boom cranes used for delivery purposes, provided the boom is 135 feet or less in length, and the material is not raised more than 100 feet in the delivery process.

4.3 Enforcement of city regulations

The Department’s Cranes and Derricks Unit enforces the city’s crane regulations. The Unit is currently staffed by 24 individuals – this includes supervisors, engineers, inspectors, and administrative personnel. Enforcement mechanisms of the Cranes and Derricks Unit are divided into two areas – plan examination and inspection.

4.3.1 Plan Examination

Plan examination by the Department encompasses the engineering reviews and

Plan examination by the Department encompasses the engineering reviews and approvals required to operate a crane in New York City. This includes engineering approval of plans and documents related to the Certificate of Approval (prototype approval) and Certificate of On-site Inspection (CN).

Current plan exam volumes in the Cranes and Derricks unit (approximately):

- Certificate of Approval applications – 2 per month
- Certificate of On-Site Inspection applications – 150 per month²
- In addition, the Cranes and Derricks unit reviews approximately 900 applications per month³ relating to scaffolding and mast climbers

During the review of a Certificate of Approval application, the plan examiner typically reviews:

- Crane manuals and load charts for completeness
- That manufacturer possesses ISO certification
- Crane design for conformance with recognized standard

During the review of a Certificate of On-Site Inspection application, the plan examiner typically reviews:

- Site conditions for suitability of crane placement, including:
 - Soil/subsurface conditions
 - Footing/support of equipment, including foundations and tie-ins
 - Clearances from obstructions
- Equipment configuration
 - Conformance of the proposed configuration with manufacturer manuals and load charts
- Calculations verifying stability of the crane

Failing a plan examination will result in the issuance of objections or outright denial of the proposed application. Approval will not be granted until the objections have been resolved to the satisfaction of the Cranes and Derricks Unit.

² Includes applications for initial permit, renewals, and amendments.

³ Includes applications for initial permit, renewals, and amendments. ..

4.3.2 Inspection

Inspections conducted by the Department fall into two areas – signoff inspections required to operate a crane (e.g. the signoffs required to obtain a Certificate of Operation (CD) and Certificate of On-Site Inspection (CN)), and inspections to verify compliance with city regulations (e.g. audits, sweeps, complaint inspections, and other inspections).⁴

2015 Inspection Numbers

- Certificate of Operation/Certificate of On-Site Inspection
 - Annual comprehensive inspection: 573
 - Unassembled/assembled inspection at the jobsite: 511
- Sweeps: 1319
- Audit inspections: 840
- Complaint inspections: 228
- Re-inspections: 82
- Other: 9

During an inspection, an inspector typically checks:

- Compliance with approved plans
- License of operator
- Conformance with operation and rigging regulations
- Crane for any signs of wear or damage

Failing an inspection can result in the issuance of a stop work order or violations. In 2015, the Cranes and Derricks unit issued:

- 198 stop work orders
- 153 violations

4.4 New York City crane activity

Crane activity in New York City is both seasonal and cyclical. There are upticks in the spring as the weather improves, and in the late autumn. The autumn surge is

⁴ Separate from inspections performed by the Department, the city’s crane regulations require crane owners, contractors, and other personnel associated with cranes to perform inspections, and maintain records of their inspections, which are to be made available to the Department upon request.

attributed to city regulations – the New York City Department of Transportation prohibits cranes from being assembled or disassembled in large sections of Manhattan between Thanksgiving and Christmas in order to minimize street closings that would disrupt holiday traffic. Over the longer term, crane activity reflects cyclical economic trends; there was a broad decline in crane activity in New York City between 2009 and 2011. The years since have witnessed a steady uptick.

There are presently 548 cranes registered to operate in New York City – that is, cranes with a valid Certificate of Operation (CD). Table 1 provides data on the number of initial Certificate of On-Site Inspection (CN) permits issued by the Department between 2008 and 2015. This data does not reflect the total number of cranes that operate within New York City in any given year; a number of cranes are exempt from Department regulations and are not tracked by the Department (see Section 4.2 for further information).

Initial crane permits	2006	2007	2008	2009	2010	2011	2012	2013	2014	2015
Tower cranes CN permits	31	38	35	8	8	18	24	30	24	42
Mobile crane CN permits	732	817	974	786	519	675	777	932	914	941
Total Permits	763	855	1009	794	527	693	801	962	938	983

4.5 Historical New York City crane incidents

The Department tracks data related to crane incidents in New York City to the extent the crane is regulated by the Department. Data does not include cranes that are exempt from Department regulations and are not tracked by the Department (see Section 4.2 for further information).⁶

“Incident” is a crane event where the Department’s Emergency Operations Center receives a notification that requires immediate inspection by the Department. An “accident” is a subset of “incident” that resulted in an injury or fatality.

⁵ Year based on earliest 'Approved' status date

⁶ In April 2012, a worker was killed when a crane collapsed at the 7-train subway extension on the Far West Side of Manhattan. In November 2015, a worker was killed when an articulating boom crane making a delivery to a jobsite in Midtown Manhattan malfunctioned. These and other incidents and accidents are not reflected in the Department’s data as they occurred with cranes that were outside of the Department’s jurisdiction at the time of the accident

While New York City strives towards zero crane incidents, the decreasing trend of crane related injuries is encouraging, even given the recent uptick in construction activity. (See Table 2 and Figure 10) Historically, dropped or mishandled loads, and other errors during crane operation (e.g. striking a building) have been the largest cause of crane incidents in New York City. Crane accidents associated with the assembly and disassembly of a crane (including the climbing or jumping of a tower crane) and the dropping or mishandling of a load historically have caused the highest number of injuries/fatalities. (See Tables 3 and 4, and Figures 11 and 12).

The data reflected in the following tables and figures covers the years 2006 through 2015.

Table 2: New York City crane incidents										
	2006	2007	2008	2009	2010	2011	2012	2013	2014	2015
Incident	14	19	27	18	21	9	15	15	10	16
Accident (incident with an injury or fatality)	4	7	7	2	6	0	4	6	4	4
# Injuries	9	8	29	2	6	0	4	12	5	10
# Fatalities	2	0	9	0	0	0	0	0	0	0

Figure 10: Crane accident data (2006 - 2015)

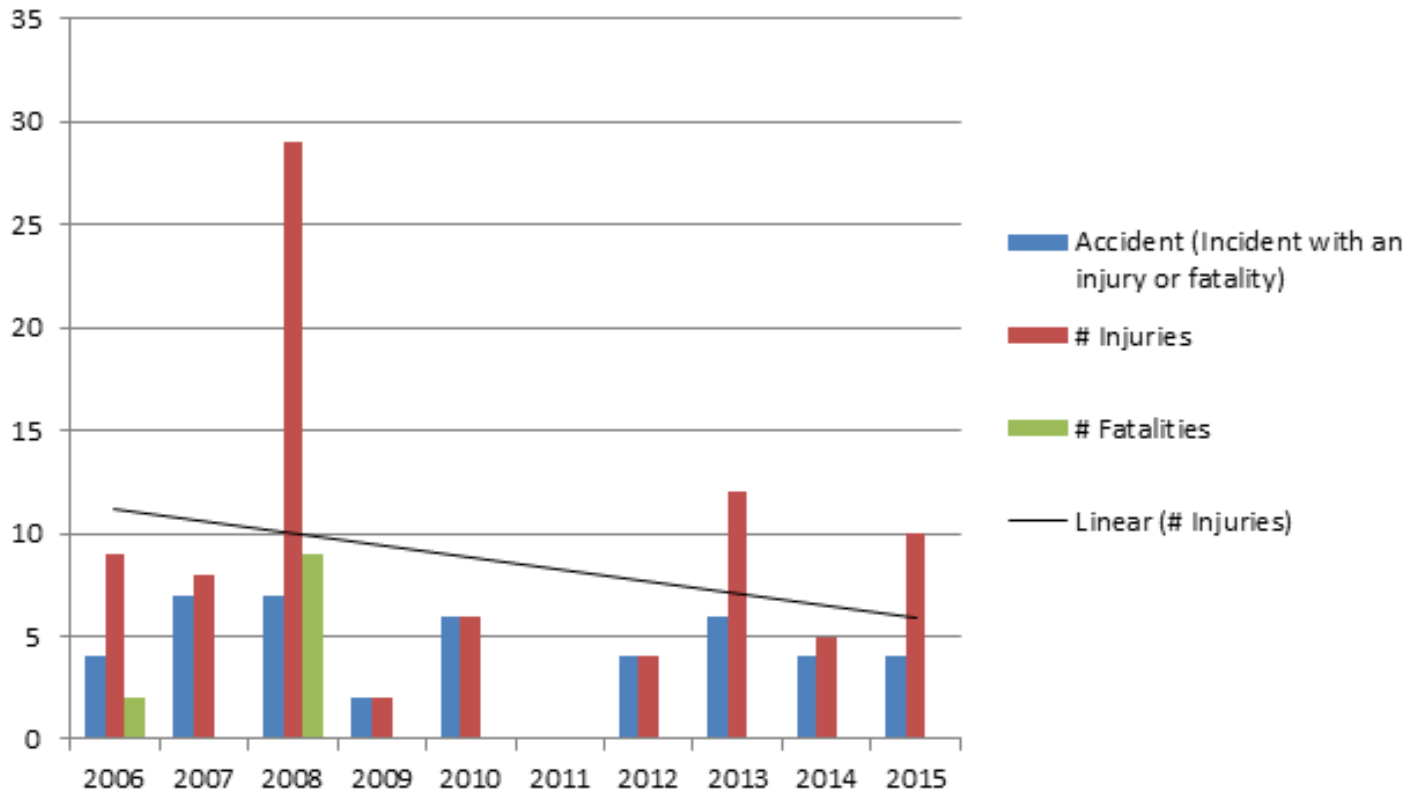

Table 3: Incidents by cause (2006 -2015)

Assembly/disassembly	15
Boom/jib collapse	9
Concrete pumping	5
Load dropped/mishandled	56
Malfunction (mechanical, electrical)	9
Operation	36
Other	14
Overturned/toppled	16
Wind	4

Figure 11: Incidents by cause (2006 - 2015)

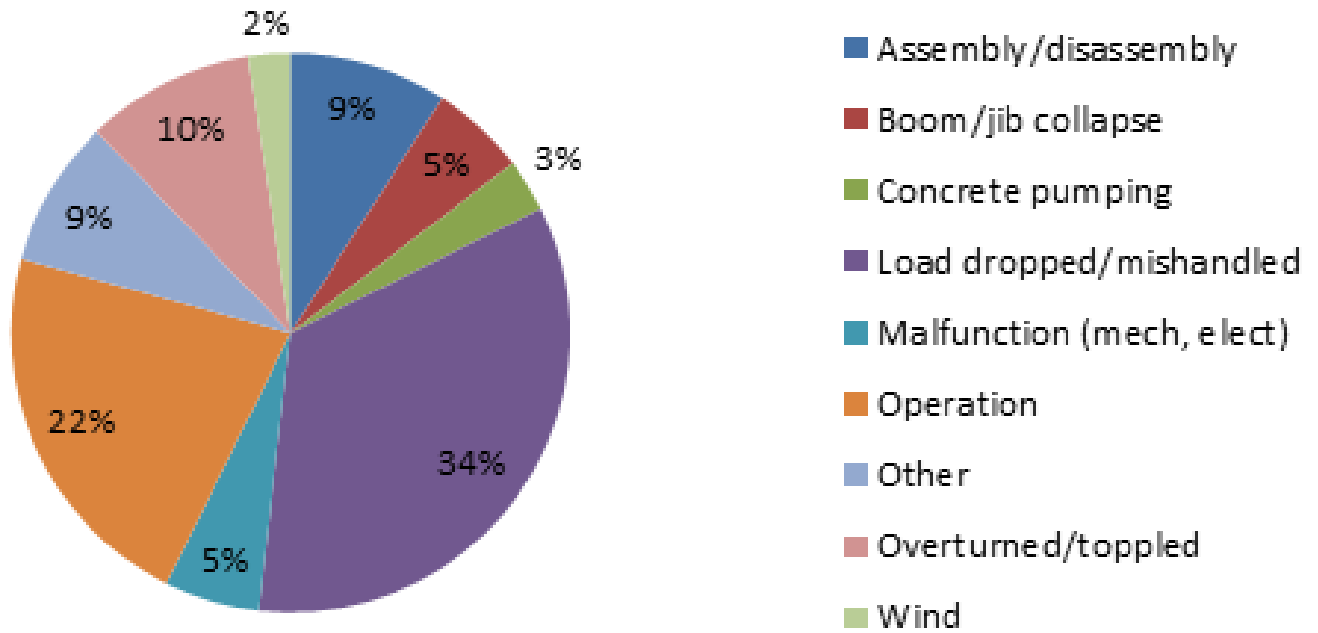
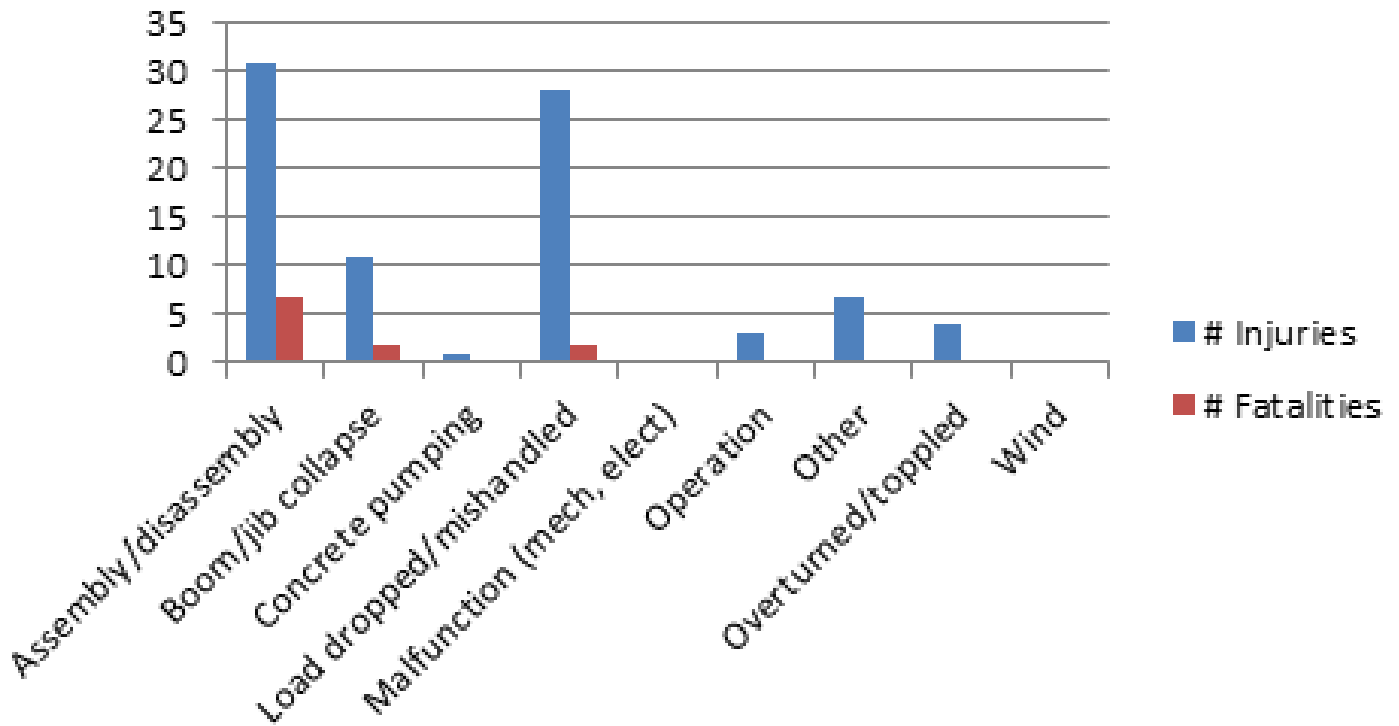

Table 4: Injuries and fatalities by cause (2006 -2015)

	Injuries	Fatalities
Assembly/disassembly	31	7
Boom/jib collapse	11	2
Concrete pumping	1	0
Load dropped/mishandled	28	2
Malfunction (mech, elect)	0	0
Operation	3	0
Other	7	0
Overtured/toppled	4	0
Wind	0	0

Figure 12: Injuries and fatalities by cause (2006 - 2015)



4.6 New York City Department of Transportation

The New York City Department of Transportation (DOT) has jurisdiction over the city’s streets and sidewalks. If a crane is to be set up or operated on a city street, a permit is required from DOT. Similarly, if a street or sidewalk needs to be closed to facilitate crane work – either on an intermittent basis or a longer term basis – a permit from DOT is required. DOT regulations require flagpersons, barricades, and signs to be provided to direct pedestrian and vehicular traffic.⁷

⁷ <http://streetworksmannual.nyc/appendices/appendix>

4.7 FDNY and OEM

In the wake of the February 5 accident, the city began working with the Fire Department (FDNY) and Office of Emergency Management (OEM) as part of its crane safety enforcement.

OEM currently provides weather forecasts to the Department every three hours. Based on forecasts and National Weather Service (NWS) data from local reporting stations (JFK, LaGuardia, Newark Airports, and Central Park), the Department has been issuing cease work orders to crane contractors when winds are forecast to exceed 30mph or have been measured at a NWS reporting station as exceeding 30mph.

Crawler crane contractors are required to notify the Department whenever they take certain actions with their crane, including assembling the crane, disassembling the crane, or lowering the boom/jib of the crane. The Department forwards these notifications to OEM; if the crawler crane activity takes place on or over a street or sidewalk, OEM will dispatch FDNY to close the street or sidewalk.

4.8 High Risk Construction Oversight (HRCO) study

Between 2008 and 2009, a team of independent experts evaluated the city's crane regulations and New York City construction industry practice. The final report, known as the High Risk Construction Oversight (HRCO) study,⁸ provided 23 crane related recommendations. In the years since, the Department has worked to implement these recommendations via rulemaking and operational changes. Where a recommendation in this study is related to a previous HRCO recommendation, it is noted in section 7 of this report.

4.9 Ongoing Department rulemaking surrounding cranes

In March 2015, the Department launched a multi-phase effort to revise RS 19-2 (now 1 RCNY 3319-01) of the city's crane regulations, with an eye towards codifying the HRCO crane recommendations and adopting ASME standards (see section 5.2). RS 19-2 had last been updated in 2006. To assist in this effort, the

⁸ The HRCO report can be found online at: http://www1.nyc.gov/assets/buildings/pdf/hrco_report.pdf
The crane related recommendations are contained in Section C. The HRCO study also reviewed high-rise concrete construction, excavations, and hoists

Department established the Crane Rule Advisory Committee (“the committee”). The committee consists of representatives from crane manufacturers, construction firms, filing engineers, real estate, and labor. The committee meets once a month to provide comment upon revisions drafted by the Department.

The first phase of this effort culminated in September 2015 with the publication of revisions relating to the Certificate of Approval (prototype approval), including manufacturer requirements and make and model design; these became effective January 1, 2016. At the time of the accident, the Department was finalizing revisions relating to the Certificate of On-Site Inspection (CN), including jobsite design and inspection to verify compliance with such. Subsequent phases are planned to review the remaining topical areas of New York City regulations.

4.10 Commissioner's Order

On March 15, 2016, the Department issued a Commissioner’s Order.⁹ The Commissioner’s Order:

- Applies only to crawler crane
- Establishes wind speed restrictions
 - Requires crawler cranes to cease operation when winds – gust or sustained – exceed 30mph
 - If the forecast indicates winds – gust or sustained – will exceed 30mph, that day’s operations must be completed before the winds reach that speed; if that day’s operations cannot be completed in time, they should not begin
 - If the manufacturer or CN requires the crane to cease operations at a lower speed, this must instead be followed
- At the end of every crawler crane shift, or when the crawler crane ceases operations due to wind, the HMO must produce a signed written record noting the out of service configuration in which the crane was left

⁹ http://www1.nyc.gov/assets/buildings/pdf/commissioner_order_crane_safety_req.pdf

- The Department must be notified of certain crawler crane activities
 - The notification must indicate if the activity will occur over, or require the closure of, a public street or sidewalk
- If the crawler crane boom/jib configuration is not rated for a wind – sustained or gust – in excess of 30mph
 - A PE must be on site while the crane is being utilized
 - The PE does not have to be the crane applicant of record or employed by the applicant
 - The PE needs to verify crane operations cease when the winds reach the threshold for the crane, and also verify that the crane was properly secured
 - The crane boom/jib must be laid down or jackknifed each night
 - In addition, if the crawler crane boom/jib configuration is not rated for a wind – sustained or gust – in excess of 20mph, the crane can only be utilized within a safety zone
 - The public is not permitted within the safety zone;
 - The distance from the crane to the boundary of the safety zone must, at a minimum, be equal to the length of the boom/jib and any other attachments;
 - The safety zone shall be established so as not to impact the public right-of-way or adjacent properties; and The safety zone shall be managed in such a manner that it can be evacuated in case of emergencies.

5.0 NATIONAL AND INTERNATIONAL CRANE REGULATIONS

This section examines national and international crane regulations to identify topical areas that are not accounted for in New York City existing regulations.

5.1 Crane Regulations across the United States

The Occupational Safety and Health Administration (OSHA), a federal agency that is part of the United States Department of Labor (DOL), regulates cranes. In the majority of the United States, OSHA crane regulations (29 CFR Part 1926, Subpart CC) are enforced by federal OSHA, or by a state agency that has entered into an agreement with OSHA to enforce OSHA regulations within the state.

However, several jurisdictions have gone above and beyond OSHA. In addition to New York City, California, Maryland, Washington state, and Chicago, IL, have developed their own comprehensive set of crane regulations. Philadelphia, PA, and Washington, DC, have developed regulations specific to tower cranes. Under federal law, city regulation must be limited to protecting the public; worker safety is reserved to OSHA and states that have an agreement with OSHA.¹⁰

5.2 Model standards for cranes

The American Society of Mechanical Engineers (ASME)¹¹ publishes a family of model standards related to cranes and rigging (the B.30 set of standards). These standards are collaboratively developed and periodically updated by volunteer committees of crane experts operating under procedures developed by ASME and accredited by the American National Standards Institute (ANSI). The standards are intended to serve as a guide to government and other regulatory bodies and may be adopted into law by legislation or rulemaking.

The ASME standards are specific to the type of crane (e.g. mobile crane, tower crane, etc.) and rigging hardware (e.g. hook, sling, etc.). Each standard provides requirements concerning the design, manufacturing, operation, use, inspection, maintenance, and repair of the subject topic. At present, ASME publishes the following standards. (Note: Not all ASME B.30 standards are applicable to New York City as the Department does not regulate cranes utilized in industrial, commercial, or marine settings, for example.)

¹⁰ See for example Gade v. National Solid Wastes Mgmt. Ass'n (90-1676), 505 U.S. 88 (1992) and Steel Inst. of New York v. City of New York, 716 F.3d 31 (2d Cir. 2013), cert. denied 134 S.Ct. 824 (2014)

¹¹ ASME is a not-for-profit membership organization that enables collaboration, knowledge sharing, career enrichment, and skills development across all engineering disciplines, toward a goal of helping the global engineering community develop solutions to benefit lives and livelihoods. Founded in 1880 by a small group of leading industrialists, ASME has grown through the decades to include more than 130,000 members in 151 countries. (<https://www.asme.org/about-asme>)

- B30.1 Jacks, Industrial Rollers, Air Casters, and Hydraulic Gantries
- B30.2 Overhead and Gantry Cranes (Top Running Bridge, Single or Multiple Girder, Top Running Trolley Hoist)
- B30.3 Tower Cranes
- B30.4 Portal and Pedestal Cranes
- B30.5 Mobile and Locomotive Cranes
- B30.6 Derricks
- B30.7 Winches
- B30.8 Floating Cranes and Floating Derricks
- B30.9 Slings
- B30.10 Hooks
- B30.11 Monorails and Underhung Cranes
- B30.12 Handling Loads Suspended From Rotorcraft
- B30.13 Storage/Retrieval (S/R) Machines and Associated Equipment
- B30.14 Side Boom Tractors
- B30.15 Mobile Hydraulic Cranes (withdrawn 1982 — requirements found in latest revision of B30.5)
- B30.16 Overhead Hoists (Underhung)
- B30.17 Overhead and Gantry Cranes (Top Running Bridge, Single Girder, Underhung Hoist)
- B30.18 Stacker Cranes (Top or Under Running Bridge, Multiple Girder With Top or Under Running Trolley Hoist)
- B30.19 Cableways
- B30.20 Below-the-Hook Lifting Devices
- B30.21 Lever Hoists
- B30.22 Articulating Boom Cranes
- B30.23 Personnel Lifting Systems
- B30.24 Container Cranes
- B30.25 Scrap and Material Handlers
- B30.26 Rigging Hardware
- B30.27 Material Placement Systems
- B30.28 Balance Lifting Units

At present, New York City has adopted those sections that relate to the design and manufacturing of cranes from ASME B30.3, B30.5, B30.6, B30.22, and B30.29.

5.3 International crane regulations

Cranes are regulated by jurisdictions around the world. In general, they cover the same topics as New York City and American regulations; however, international jurisdictions do also cover areas not considered by New York City or American regulations:

- **Age limits for cranes.** Singapore has established an age limit for cranes; from 20 to 30 years, depending on the type of crane. While not setting a hard limit, Australian standards require cranes undergo a Certification and Refurbishment process once they reach the end of their design life.¹³

¹² OSD/ ENG CIR/ LE 3/02.

¹³ AS 2550: *Cranes, hoists and winches – Safe use series*

- **Anemometer.** Singapore¹⁴ and New Zealand¹⁵ require tower cranes to be equipped with an anemometer. The anemometer measurements are displayed in the operator’s cabin; transmission of data for offsite monitoring is not required.
- **Data loggers.** Singapore requires mobile cranes to be equipped with a data logger.¹⁶ The data logger must be capable of recording various aspects of the crane’s operation and movement, including the crane configuration, radius of load, status of limit switches, and operator overrides. The data logger must be equipped with data security and anti-tampering features. The data must be able to be downloaded by crane owners and users on a regular basis, and generate readable reports. Real time transmission of data for offsite monitoring is not required.

5.4 United States Navy crane regulations

The United States Navy utilizes cranes at its yard and facilities, and has developed its own set of regulations for cranes.¹⁷ The Navy is unique in that it exercises command and control authority over the cranes it regulates, and its regulations address concerns not found in the construction industry – for example, preventing interference with radar. Nevertheless, Navy regulations do contain provisions that can be translated into the New York City construction industry and which are not yet accounted for in New York City’s existing crane regulation.

- **Anemometer.** The United States Navy requires cranes to be equipped with an anemometer. The anemometer measurements are displayed in the operator’s cabin; transmission of data for offsite monitoring is not required .
- **Jobsite crane supervisor.** The Navy requires a Rigger-in-Charge (RIC). The RIC has overall control of the crane operation including: planning all aspects of the lift; determining the weight of the load to be lifted; establishing the appropriate method of communication with the operator; ensuring the load is properly rigged; ensuring the crane operating envelope remains clear of all obstructions; providing signals to the operator or

¹⁴ [Code of Practice Safe Lifting Operations Revised 2014.pdf](#)

¹⁵ [Approved Code of Practice for Cranes 2009.pdf](#)

¹⁶ [Workplace-safety and health/lifting equipment/data-loggers for mobile cranes](#)

¹⁷ [NAVFAC Navy Crane Center](#)

assigning another rigger or signal person to provide the signals; and conducting the operation in a safe manner. The RIC coordinates the activities of other crane team members.

- **Supervision of assembly/disassembly.** The Navy requires the assembly or disassembly of a crane to be supervised; as part of the assembly/disassembly process, the supervisor is responsible for addressing specific hazards (e.g. site and ground conditions, weather conditions, etc.) and reviewing assembly/disassembly procedures with crewmembers prior to the commencement of work.

Table 5: Comparison of New York City crane regulations to other jurisdictions

Table 5 compares New York City’s crane regulations against that of OSHA, ASME, the United States Navy, other jurisdictions within the United States that have developed their own comprehensive set of crane regulations, and select international jurisdictions highlighted in section 5.3. Except where otherwise noted in the footnotes, the categories in the table mirror those described in section 4.1.

	NYC	OSHA ¹⁸	ASME ¹⁹	US Navy ²⁰	California ²¹	Chicago ²²	Maryland ²³	Washington State ²⁴	Australia ²⁵	New Zealand ²⁶	Singapore ²⁷
Anemometer required ⁴³	No	No	No	Yes	No	No	No	No	No	Yes	Yes
Data logger required ⁴⁴	No	No	No	No	No	No	No	No	No	No	Yes
Operating procedures	Yes	Yes	Yes	Yes	Yes	Yes	Yes	Yes	Yes	Yes	Yes
Rigging standards	Yes	Yes	Yes	Yes	Yes	Yes	Yes	Yes	Yes	Yes	Yes
Licensing of riggers	Yes	No	No	No	No	No	No	No	Yes ⁴⁵	No	No
Training or certification for rigging workers	Yes	Yes	No	Yes	Yes	No	Yes	Yes	Yes	Yes	Yes
Assembly/disassembly supervision	Tower cranes only	Yes	Yes	Yes	Yes	No	Yes	Yes	Yes	Yes	Yes
Jobsite crane supervisor	Only where licensed rigger required	For certain critical operations only	Yes	Yes	For certain critical operations only	No	For certain critical operations only	Yes	Yes	Yes	Yes

	NYC	OSHA ¹⁸	ASME ¹⁹	US Navy ²⁰	California ²¹	Chicago ²²	Maryland ²³	Washington State ²⁴	Australia ²⁵	New Zealand ²⁶	Singapore ²⁷
Manufacturer requirements	Yes	No	No	n/a ²⁸	No	No	No	No	No	Yes	Yes
Make and model design	Yes	Yes	Yes		Yes	Yes	Yes	Yes	Yes	Yes	Yes
Make and model approval	Yes	No	No		No	No	No	No	No	Yes, by an inspection body	Tower cranes only ²⁹
Age limits for cranes ³⁰	No	No	No		No	No	No	No	Major inspection required ³¹	No	Yes
Registration of cranes ³²	Yes	No	No		No	No	No	Yes	No	No ³³	Yes ³⁴
Frequent and periodic inspections	Yes	Yes	Yes	Yes	Yes	Yes	Yes	Yes	Yes	Yes	Yes

¹⁸ 29 CFR 1926

¹⁹ ASME B30 family of standards

²⁰ http://www.navfac.navy.mil/navfac_worldwide/specialty_centers/ncc/about_us/resources/p307.html

²¹ Cal. Code Regs., Title 8, §1610

²² Chicago has developed its crane regulatory system through administrative and enforcement mechanisms; it is currently in the process of codifying certain elements

²³ COMAR 09.12.26

²⁴ WAC 296-155-529

²⁵ AS 2550: Cranes, hoists and winches - Safe use series

²⁶ <https://www.business.govt.nz/worksafe/information-guidance/all-guidance-items/acop-cranes/cranes-acop-2009.pdf>

²⁷ Singapore has developed crane regulations via legislation, rulemaking, and the issuance of orders (known as circulars) by the Ministry of Manpower. See, for example, *Singapore Workplace Safety & Health Act, SS536 : CP for Safe Use of Mobile Cranes* and *CP 62: CP for Safe Use of Tower Cranes*

²⁸ Navy regulations do not speak to manufacturer requirements, age limits, or registration of cranes. However, the Navy procures and operates the cranes it regulates; it is likely the Navy has analogous provisions via contract procurement and fleet management procedures.

²⁹ <http://www.mom.gov.sg/workplace-safety-and-health/find-a-type-approved-equipment/find-a-type-approved-tower-crane>

³⁰ A requirement by the jurisdiction that prohibits the operation of cranes once they reach a certain age.

³¹ Australian standards do not impose a strict age limit; however, mechanical components must be removed from the crane, inspected, and recertified every 10 years, and structural components every 25 years.

³² Does not include DMV vehicle registration.

³³ The Crane Association of New Zealand maintains a private database of crane owners and cranes in each owner's fleet. <http://www.cranes.org.nz/crane-search.html>

³⁴ <http://www.mom.gov.sg/workplace-safety-and-health/lifting-equipment/>

	NYC	OSHA ¹⁸	ASME ¹⁹	US Navy ²⁰	California ²¹	Chicago ²²	Maryland ²³	Washington State ²⁴	Australia ²⁵	New Zealand ²⁶	Singapore ²⁷	
Comprehensive inspection	Yes, by department	No	No	Yes	Yes, by third party crane certifier	No	No	Yes, by third party crane certifier	No ³⁵	Yes, by certified equipment inspector	Yes, by an authorized examiner	
Maintenance and repair requirements	Yes	Yes	Yes	Yes	Yes	Yes	Yes	Yes	Yes	Yes	Yes	
Approval of repairs	Yes	No	No	Yes	No	Only for welds	No	No	No	No	No ³⁶	
Jobsite specific design	Yes	Yes	Yes	n/a ³⁷	Yes	Yes	Yes	Yes	Yes	Yes	Yes	
Jobsite specific permit ³⁸	Yes	No	No		Only for tower cranes	Only cranes that require a foundation or building	No	No	No	No	No	No
Inspection to verify compliance with jobsite permit												
Licensing of crane operators	Yes	No ³⁹	No	Yes	No	Yes	No	No	Yes ⁴⁰	No	Yes ⁴¹	
Training or certification for crane operators ⁴²	Yes	Yes	Yes	Yes	Yes	Yes	Yes	Yes	Yes	Yes	Yes	
Safety devices and operational aids	Yes	Yes	Yes	Yes	Yes	Yes	Yes	Yes	Yes	Yes	Yes	

³⁵ The Australian crane industry has developed a voluntary program that accredits crane certifiers and encourages crane owners to utilize a certified crane inspector to annually inspect and certify their cranes. <http://cranesafe.com.au/about/cranesafe-assessment-program>

³⁶ Repairs must be reported to the Ministry of Manpower.

³⁷ Navy regulations do not speak to jobsite design or permit; however, the Navy controls the sites where its cranes are utilized, and it is likely an analogous planning and approval process exists.

³⁸ Does not include DOT permits to close streets or sidewalks.

³⁹ Connecticut, Hawaii, Massachusetts, Montana, New Jersey, New Mexico, New York state, Pennsylvania, Rhode Island, and West Virginia require crane operators to possess a license issued by the state.

⁴⁰ Licenses are issued by Australian states. See New South Wales (Sydney) as an example: <http://www.safework.nsw.gov.au/licences-and-registrations/licences/high-risk-work/licences/crane-licences>

⁴¹ <http://www.mom.gov.sg/workplace-safety-and-health/wsh-professionals/crane-operator>

⁴² A requirement by the jurisdiction that requires crane operators to possess a specified level of training or hold an independent certification in order to operate a crane

6.0 TRANSPORTATION INDUSTRIES

The transportation industry is the most analogous to the crane industry – both rely on skilled individuals to safely operate and maintain large, complex moving pieces of equipment. Although differences in regulatory and economic environments may not allow for the direct translation of requirements from the transportation industry into construction, best practices can be emulated. This section identifies topical areas that are not accounted for in New York City existing crane regulations.

- **Electronic recordkeeping.** The Federation Aviation Administration (FAA) allows records, such as pilot logbooks and maintenance records, to be electronically stored and signed. Companies wishing to utilize an electronic recordkeeping system must receive FAA approval.⁴⁶ In December 2015, the Federal Motor Carriers Safety Administration (FMCSA) promulgated a rule concerning electronic logging devices (ELD); it mandates that carriers and drivers who are using paper logs or logging software transition to ELDs no later than December 18, 2007.
- **Familiarization with specific makes and models of equipment.** The FAA requires pilots to be rated on specific makes and models of equipment (e.g. Boeing 737 vs 747).⁴⁷ The Federal Railroad Administration (FRA) requires employers to certify engineers⁴⁸ to the specific route he or she will be operating.⁴⁹
- **GPS tracking.** The New York City Taxi and Limousine Commission (TLC) has launched a pilot program to test GPS-based taxi meters.⁵⁰ UPS trucks are equipped with sensors to report vehicle speed and direction of travel. This data is combined with GPS data to assist with vehicle and route management.⁵¹

⁴⁶ http://www.faa.gov/documentLibrary/media/Advisory_Circular/AC_120-78_final.pdf

⁴⁷ <http://registry.faa.gov/TypeRatings/?YouCantCacheThis=1462186508>

⁴⁸ http://www.ecfr.gov/cgi-bin/text-idx?c=ecfr;sid=1d516dc2394ba200238dcf6dab427b6d;rgn=div5;view=text;node=49%3A4.1.1.1.34;idno=49;cc=ecfr#se49.4.240_1101

⁴⁹ <http://www.bls.gov/ooh/transportation-and-material-moving/railroad-occupations.htm#tab-4>

⁵⁰ http://www.nyc.gov/html/tlc/html/industry/alt_tech_pilot_program.shtml

⁵¹ <https://www.ups.com/content/us/en/bussol/browse/leadership-telematics.html>

7.0 RECOMMENDATIONS

Based on our review of the Department’s crane regulations and enforcement scheme, national and international crane regulations, best practices from the transportation industry, and comments received from the public and industry stakeholders, the working group offers 23 recommendations divided into 4 topical areas. These recommendations reflect regulations or best practices that are currently not accounted for in New York City, as well as enhancements that can be made to the city’s already robust regulatory framework.

We recommend that the Department work through its existing crane rule advisory committee to develop specific text to adopt these recommendations via rule or legislation. The Department should supplement this work via the issuance of Commissioners Orders and providing training to the industry, as necessary.

When enacted, these recommendations will strengthen the city’s already robust regulatory framework by applying emerging best practices with technological tools, crane engineering, and design enhancements, ensuring the operation of cranes in New York City remain the safest in the world.

USING THE LATEST TECHNOLOGY

New York City crane industry operations and oversight have always been paper dependent, creating missed opportunities for recording and reviewing crane activities. The Department’s ability to regulate the crane industry, and the industry’s ability to mitigate hazards, will be improved by embracing the latest technological innovations.

- 1. Data loggers.** Data loggers, a technological enhancement that records activity over time, should be required. Data recorded by the logger must be made available to the Department at the Department’s discretion. The creation of this data and its availability to the Department as well as to the crane owner, operator, and other critical partners in crane operations will provide transparency and accountability in crane operations. Data to be recorded can include the crane configuration, radius of the load, status of limit switches, and operator overrides. A mechanism to record the name and license number of individual operating the crane should also be provided. The Department should prioritize implementation of this recommendation based on available

technology. Singapore currently requires mobile cranes to be equipped with a data logger. Adoption of this measure was also recommended by the HRCO study; specifically HRCO recommendation C-22..

- 2. GPS tracking.** Mobile cranes have the ability to relocate around New York City and to other jurisdictions. We recommend making it easier for the Department to know where mobile cranes are operating at all times. A GPS tracking device should be installed on all mobile cranes that are permitted to operate in New York City. Such an enhancement will enable the Department to better route inspectors and conduct real time audits of mobile crane activity in the city. Similar to the New York City Taxi and Limousine Commission (TLC), the Department should launch a pilot program to study the use of GPS tracking before fully mandating. This recommendation exceeds HRCO recommendation C-17, which recommended Department tracking of mobile cranes, but did not call for GPS tracking.

- 3. Electronic recordkeeping.** The Department is currently working to digitize its inspection and permitting processes; it is recommended that the Department prioritize this work as it relates to cranes and request that the city provide all appropriate resources to implement this work in a timely fashion. This will allow the Department to more efficiently process permit applications and track inspection results. In addition, the Department should explore mechanisms that will allow industry to maintain electronic records related to cranes (e.g. manuals, logs, inspection reports) in a manner that can be accessed by the Department upon request. Shifting the crane industry to electronic recordkeeping will make it easier for the Department to receive and review industry records. The Federation Aviation Administration (FAA) allows records, such as pilot logbooks and maintenance records, to be electronically stored and signed. Companies wishing to utilize an electronic recordkeeping system must receive FAA approval.

- 4. Anemometers.** It is recommended that the Department mandate that cranes operating in New York City be equipped with an anemometer; except where the crane manufacturer otherwise specifies, the anemometer should measure a 3-second wind gust. The anemometer will enable the crane to measure winds at the jobsite. Wind conditions can vary across the city, and may not reflect what is reported by the National Weather Service at its Central Park or airport metrological stations - for example, winds may be calm at a metrological station, but breezy within the canyons of Manhattan; in the inverse, winds may be strong along the waterfront at JFK airport, but a jobsite blocked by buildings may not experience winds. Where the crane is equipped with an anemometer, the reading recorded at the jobsite should

take precedence over National Weather Service measurements. Singapore and New Zealand currently require tower cranes to be equipped with an anemometer, and the United States Navy requires cranes under its control to be equipped with an anemometer.

- 5. Pinpoint forecasting.** Forecasts are an important planning tool. Where the forecast indicates winds will exceed the operating threshold for the crane, the crane should be secured in advance. National Weather Service forecasts are issued on a regional level; however, wind conditions can vary across the city. Emerging technology is increasingly able to merge regional forecasts and block by block topology to provide jobsite specific forecasts. It is recommended that the department mandate that contractors at large jobsites, or where utilizing a crane with a long boom/jib combination, engage a private metrological service to provide pinpoint forecasting.
- 6. Age limit.** [Introductory Number 443 of 2014](#) is currently pending before the New York City Council. It is recommended that this bill be advanced by the City Council. This bill, if adopted, will impose an age limit on cranes operating in New York City. The phasing out of older cranes will facilitate the utilization of cranes with newer technology and safety features. Singapore currently limits the age of cranes. Adoption of this measure was also recommended by the HRCO study; specifically HRCO recommendation C-14. Introductory Number 443 of 2014 also mandates that cranes be outfitted with a load cycle counter; implementation of this measure will partially fulfill recommendation 1.
- 7. Self-erecting tower cranes.** Self-erecting tower cranes represent a new type of technology, which are increasingly utilized in Europe to construct and service low to mid-rise buildings. Despite the similar name, self-erecting tower cranes are not assembled or operated like a traditional high-rise tower crane. Self-erecting tower cranes are driven to the jobsite and can be set up in under an hour by unfolding in a controlled sequence. They provide good reach and lifting capacity while having a small footprint, making them suited to operating within tight spaces. The Department's current crane regulations do not address self-erecting tower cranes. It is recommended that the Department develop a regulatory and licensing system specific to self-erecting tower cranes. This will enable industry to utilize the flexibility and efficiencies offered by self-erecting tower cranes while ensuring safe operation.

ADOPTING MODEL STANDARDS

The American Society of Mechanical Engineers (ASME), a nonprofit professional association of mechanical engineers, publishes a family of model standards (the B30 standards) relating to cranes and rigging. These standards are collaboratively developed and periodically updated by volunteer committees of crane experts operating under procedures developed by ASME and accredited by the American National Standards Institute (ANSI). In 2015, the Department launched a multi-phase effort to revise the city's crane regulations, and adopt ASME standards (see section 4.9). At present, this effort has resulted in New York City adopted specific sections of those standards that relate to the design and manufacturing of cranes. A complete list of ASME B.30 standards is provided in section 5.2. The Department should continue this work.

- 8. Model standards for cranes and rigging.** It is recommended that the Department adopt relevant ASME standards for cranes and rigging. This will incorporate the latest thinking of the nation's top crane experts directly into the city's regulations. Appropriate modifications should be made to account for the city's characteristics. Adoption of ASME standards for cranes was also recommended by the HRCO study; specifically HRCO recommendation C-16. This recommendation also exceeds HRCO recommendation C-4, which recommended only limited enhancements to rigging regulations.

GREATER INDUSTRY ACCOUNTABILITY

The Department's Cranes and Derricks Unit has three primary roles - issuing permits, deeming cranes fit to operate, and performing inspections to verify compliance with city regulations. The Department should develop a regulatory framework to shift the responsibility for certain regulatory activities to qualified and monitored private entities. Equally, similar to the site safety model used in high rise construction in New York City, the Department should create private positions within the crane industry to verify compliance with city regulations at crane jobs. Once implemented, these recommendations will allow the Department to more efficiently deploy its resources, perform surprise spot checks and audits, and focus on areas of emerging risk or problem actors.

- 9. Third party crane certifiers for comprehensive inspection.** New York City is the only government body that performs an annual comprehensive inspection of a crane and deems it fit to operate. This inspection requires knowledge and expertise specific to the make and model of crane. California, Washington State, New Zealand, and Singapore have developed systems of licensed or accredited certifiers whose responsibility it is to

inspect and signoff cranes as fit to operate. Crane certifiers are only authorized to inspect the types of cranes for which they have demonstrated knowledge and experience. The regulatory framework utilized in these other jurisdictions should be studied and used as a potential basis for a system in New York City. Appropriate modifications should be made to account for the city's characteristics. Adoption of this measure was also recommended by the HRCO study; specifically HRCO recommendation C-3.

- 10. Risk-based plan examination.** It is recommended that the Department evaluate the plan exam functions of the Department's Cranes and Derricks unit utilizing a risk-based model to identify areas of review to best utilize the Department's resources. A system to audit applications or spot check certain topical areas should be developed. This will allow the Department to more efficiently focus its engineering resources.
- 11. Adjust staffing models to address cyclical work and need for specialized expertise.** The Department should explore the possibility of adjusting its staffing model in order to accommodate fluctuating application volumes and the need for more specialized crane expertise. This could include an evaluation of supplementing plan examination and inspection activities with outside review. It might also include contracting with an outside engineering firm or authorizing third party entities who meet criteria established by the Department. For particularly specialized or complex applications, such a system could allow the Department to leverage outside expertise. The volume of crane applications varies over the course of a year - with spikes in the spring and late autumn. Adjusting staffing structures or retaining outside expertise could enable the Department to more efficiently process applications during peak times.
- 12. Assembly/disassembly supervision.** It is recommended that the Department mandate that a specific person be responsible for supervising the assembly or disassembly of a mobile crane. This will ensure a proper chain of command is in place during this work. The individual should possess appropriate training or experience, as determined by the Department. OSHA has developed the position of assembly/disassembly supervisor. This regulatory framework should be studied and incorporated in New York City's regulations. Appropriate modifications should be made to account for the city's characteristics.
- 13. Post assembly inspection.** It is recommended that the Department mandate that appropriate personnel as defined by the Department, for example, the assembly/disassembly supervisor, crane operator, or professional engineer, inspect the crane after it has been assembled to

verify that it has been properly assembled. A record of such inspection must be recorded.

- 14. Lift director.** It is recommended that the Department mandate that a specific person is present at the jobsite full time, charged with supervising the overall activity of the crane and monitoring compliance with city crane regulations; the crane operator would still be responsible for the safe operation of the crane, and the rigger responsible for safe rigging. The American Society of Mechanical Engineers (ASME) B30.5 standard has developed the position of lift director. The United States Navy utilizes a Rigger-in-Charge. The regulatory framework utilized in these other jurisdictions should be studied and used as a basis for a system in New York City. Appropriate modifications should be made to account for the city's characteristics. The duties of the related ASME position of site supervisor and the current New York City position of crane safety coordinator should also be reviewed to determine how they best fit into the framework of a lift director.
- 15. Pre-shift meeting and inspection.** It is recommended that the Department mandate that the crane operator, assembly/disassembly supervisor, lift director, rigging supervisor, and other personnel, as appropriate, meet prior to the start of each shift and review the day's planned activities, pedestrian and traffic controls, weather conditions and forecasts, wind speed thresholds for the crane configuration, sequence to secure the crane if high winds occur, hazards specific to the jobsite or the crane configuration, and any other appropriate items. An inspection of the crane and rigging hardware must also be conducted to verify that they are in a safe condition and in accordance with the approved plans and permits. Meeting attendance, subjects covered, and the results of the inspection must be recorded. This will provide a daily check before crane operations commence, similar to how airplanes are readied for flight.
- 16. Monitoring weather conditions during work.** City regulations assign responsibility to the crane operator to monitor wind speed and to stop work and secure the crane if winds prove unsafe. This responsibility is appropriate and will be aided by the installation of an anemometer on the crane (see recommendation #4). It is recommended that the Department mandate that the lift director (see recommendation #14) periodically monitor forecasts and receive weather advisories (see recommendations #5 and #17), and coordinate with the operator to cease operation and secure the crane if necessary.

- 17. Department issued advisories in advance of inclement weather.** Contractors should monitor weather conditions at their jobsite (see recommendation #16). The Department should issue weather advisories with the goal of putting contractors on notice of potential conditions. The Department should reserve its authority to issue orders to cease operation only in anticipation of extreme weather (e.g. a blizzard, tropical system, or similar extreme weather).
- 18. Post-shift check.** It is recommended that the Department mandate that the crane operator and lift director, at the end of each shift, review the latest forecast and verify and record that the crane has been properly secured for forecasted overnight or weekend conditions. This recommendation will codify similar provisions to the Commissioner's Order of March 15, 2016, and apply them to all cranes.
- 19. Clearly indicate wind speed thresholds and securing sequence.** It is recommended that the Department mandate that the wind speed threshold for the crane configuration, as well as the sequence to secure the crane in anticipation of high winds, be submitted to the Department as part of the Certificate of On-Site Inspection (CN) application. Such submittal must be kept in the crane cab for easy access by the crane operator and other appropriate personnel as defined by the Department. This recommendation will codify similar provisions in the Commissioner's Order of March 15, 2016, and apply them to all cranes.
- 20. Restrictions on cranes with lower wind thresholds.** New York City's current regulations set a wind speed operational limit of 30mph. This is an appropriate standard, and should be measured at the jobsite via an anemometer installed on the crane (see recommendation #4). However, a small percentage of cranes with a long boom/jib combination are required by the crane manufacturer to cease operations and be lowered to the ground at a wind speed under 30mph. In the event such a threshold is 20mph or less, it is recommended that the Department codify the safety zone restriction in the Commissioner's Order of March 15, 2016, and restrict these crane configurations to a safety zone that is closed to the public and sufficiently set back from the public, open streets/sidewalks, and occupied buildings. In the event the threshold is above 20mph but below 30mph, the Department should only allow such a configuration if the crane is utilized in such a safety zone, or if a plan for monitoring and securing the crane is submitted to the city and approved by appropriate city agencies. The plan for monitoring and securing the crane must be site specific, detail the safeguards to be provided for the public and adjoining property, monitoring protocols and thresholds for wind and other conditions, emergency response procedures,

21. Focused city coordination. The Commissioner’s Order of March 15, 2016, requires contractors to notify the Department of certain crawler crane activities, regardless of the size or location of the crane. Based on this notification, the Department coordinates with the Office of Emergency Management (OEM), which dispatches Fire Department resources as appropriate. The Department should rescind this blanket approach and instead work with the Office of Emergency Management, the Department of Transportation, and the Fire Department to develop tailored notification and response protocols focused on cranes that meet certain thresholds established by the Department (e.g. size of the crane, location in high traffic areas, cranes that have a low wind speed operational limit, or in anticipation of a blizzard, tropical system, or similar extreme weather). This will enable the city to focus resources on cranes and scenarios that will benefit from an enhanced level of coordination with government agencies.

TRAINING AND LICENSING ENHANCEMENTS

To operate a crane in New York City, one must possess a Hoisting Machine Operators license (HMO). The city’s current licensing framework is a combination of two systems grafted on top of one another. The older system, dating to the 1960s, is divided into three classes – A, B, and C. Depending on the class, operators are allowed to operate cranes (of any type) with a certain capacity and boom length. The newer system, implemented in the late 2000s, incorporates an OSHA mandate for crane operators to be certified as to the type of equipment (e.g. tower crane vs crawler crane). The following recommendations are aimed at providing more specific training.

22. Orientation for cranes with a long boom/jib configuration. Prior to the operation of a crane with a long boom/jib combination, it is recommended that the Department mandate that the operator, assembly/disassembly supervisor, and lift director complete an orientation process specific to the crane configuration. The orientation should be provided by appropriate entities, as determined by the Department, prior to the use of the crane. Appropriate entities could include the crane owner or crane manufacturer. A record of the orientation must be kept at the jobsite and provided to the Department upon request.

23. Create specific licensing endorsement for cranes with a long boom/jib configuration. HMO A and C Class operators are restricted to operating cranes with a boom/jib of 200 feet or less in length. HMO Class B operators are unrestricted. These thresholds were established in the 1960s; however, in the decades since, technology has enabled cranes to reach greater distances. Class B HMOs should be restricted from operating cranes

with a long boom/jib configuration, as determined by the Department, unless they hold a specific licensing endorsement for such a crane. The Department should determine the appropriate mechanism to earn the endorsement - training, hands on experience, simulator experience, examination, or some combination thereof studied and incorporated in New York City's regulations. Appropriate modifications should be made to account for the city's characteristics.

