

**CITY OF NEW YORK
DEPARTMENT OF BUILDINGS**

Pursuant to Administrative Code Section 27-131, the following equipment or material has been found acceptable for use in accordance with the Report of Materials and Equipment Acceptance (MEA) Division.

**Richard C. Visconti, R.A., Acting Commissioner
MEA 97-00-M**

Report of Material and Equipment Acceptance Division

Manufacturer - Star Maling Og Lakkfabrikk A/S, P.O. Box 593, Lierstranda, Norway.

Trade Name(s) - Carboline Nullifire S606.

Product - Mastic coating for fire protection, for Class II Buildings.

Pertinent Code Section(s) - 27-323, 27-324.

Prescribed Test(s) - RS 5-2 (ASTM E119).

Laboratory - Underwriters Laboratories, Inc.

Test Report - UL File R11193.

Description - Type Nullifire S606 mastic coating per requirement of Underwriters Laboratories Inc. is designed to fire-proof interior steelwork of steel beams, columns, tubes, pipe and bulkhead in Design Nos. X632, X633 and X634.

Fire Resistance Ratings - ANSI/UL 263

Design No. X632

November 30, 1999

Ratings — 1, 1-1/2 and 2 Hrs. (See Item 2)

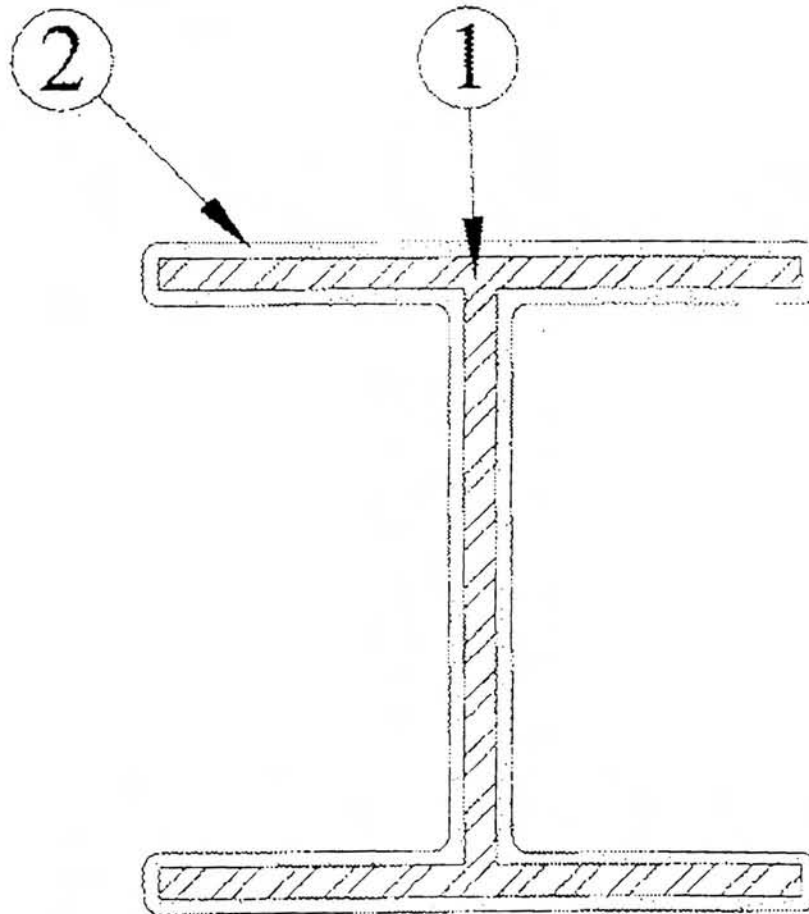

1. **Steel Column** Wide flange steel columns with the minimum sizes shown in the tables below. Columns shall be free of dirt, loose scale and oil. Column shall be primed with a red oxide zinc phosphate primer.
2. **Mastic Coating** Coating spray, brush or trowel applied directly from containers to desired thickness. See table below for appropriate final dry thickness.

Ratings, Hr.

STEEL SIZE	W/D	Hp/A	1	1-1/2	2
W5x19	0.65	206	0.092	0.177	NR
W6x16	0.58	231	0.092	0.188	NR
W6x25	0.69	194	0.092	0.170	NR
W8x21	0.57	235	0.092	0.192	NR
W8x24	0.59	227	0.092	0.188	NR
W8x28	0.68	197	0.092	0.172	NR
W8x31	0.66	203	0.092	0.175	NR
W8x35	0.74	181	0.088	0.162	NR
W8x40	0.84	159	0.081	0.148	0.216
W8x48	1.00	134	0.071	0.130	0.190
W8x58	1.19	113	0.062	0.114	0.166
W8x67	1.36	99	0.055	0.102	0.150
W10x26	0.61	220	0.100	0.184	NR
W10x30	0.70	191	0.092	0.168	NR
W10x33	0.66	203	0.095	0.175	NR
W10x39	0.78	172	0.085	0.156	0.227
W10x45	0.89	151	0.077	0.142	0.207
W10x49	0.84	159	0.081	0.148	0.216
W10x54	0.92	146	0.075	0.139	0.202
W10x60	1.02	131	0.070	0.128	0.187
W10x68	1.14	118	0.064	0.118	0.172
W10x77	1.28	105	0.058	0.108	0.157
W10x88	1.45	92	0.052	0.097	0.142
W10x100	1.63	82	0.047	0.088	0.129
W10x112	1.81	74	0.043	0.081	0.118
W12x30	0.60	223	0.092	0.186	NR
W12x35	0.70	191	0.092	0.168	NR
W12x40	0.74	181	0.088	0.162	NR
W12x45	0.82	163	0.082	0.151	0.220
W12x50	0.91	147	0.076	0.140	0.204
W12x53	0.85	158	0.080	0.147	0.214

W12x58	0.93	144	0.075	0.138	0.200
W12x65	0.92	146	0.075	0.139	0.202
W12x72	1.02	131	0.070	0.128	0.187
W12x79	1.11	121	0.065	0.120	0.176
W12x87	1.22	110	0.060	0.112	0.163
W12x96	1.34	100	0.056	0.104	0.151
W12x106	1.46	92	0.052	0.097	0.141
W12x120	1.64	82	0.047	0.088	0.128
W12x136	1.84	73	0.043	0.079	0.116
W12x152	2.04	66	0.039	0.072	0.106
W12x170	2.26	59	0.035	0.066	0.097
W12x190	2.49	54	0.031	0.055	0.079
W12x210	2.72	49	0.031	0.055	0.079
W12x230	2.94	46	0.031	0.055	0.079
W12x252	3.19	42	0.031	0.055	0.079
W12x279	3.48	38	0.031	0.055	0.079
W12x305	3.75	36	0.031	0.055	0.079
W12x336	4.07	33	0.031	0.055	0.079
W14x34	0.63	213	0.092	0.180	NR
W14x38	0.70	191	0.092	0.168	NR
W14x43	0.75	179	0.087	0.160	NR
W14x48	0.83	161	0.081	0.149	0.218
W14x53	0.91	147	0.076	0.140	0.204
W14x61	0.92	146	0.075	0.139	0.202
W14x68	1.03	130	0.069	0.127	0.186
W14x74	1.11	121	0.065	0.120	0.176
W14x82	1.22	110	0.060	0.112	0.163
W14x90	1.07	125	0.067	0.124	0.181
W14x99	1.17	115	0.063	0.116	0.168
W14x109	1.28	105	0.058	0.108	0.157
W14x120	1.40	96	0.054	0.100	0.146
W14x132	1.54	87	0.050	0.092	0.135
W14x145	1.63	82	0.047	0.088	0.129

W14x159	1.77	76	0.044	0.082	0.120
W14x176	1.95	69	0.040	0.075	0.111
W14x193	2.12	63	0.037	0.070	0.103
W14x211	2.30	58	0.035	0.065	0.096
W14x233	2.52	53	0.031	0.055	0.079
W14x257	2.75	49	0.031	0.055	0.079
W14x283	3.00	45	0.031	0.055	0.079
W14x311	3.26	41	0.031	0.055	0.079
W14x342	3.55	38	0.031	0.055	0.079
W14x370	3.80	35	0.031	0.055	0.079
W14x398	4.04	33	0.031	0.055	0.079
W14x426	4.29	31	0.031	0.055	0.079
W14x455	4.54	30	0.031	0.055	0.079
W14x500	4.91	27	0.031	0.055	0.079
W14x550	5.32	25	0.031	0.055	0.079
W14x605	5.75	23	0.031	0.055	0.079
W14x665	6.21	22	0.031	0.055	0.079
W14x730	6.68	20	0.031	0.058	0.079
W16x31	0.59	227	0.092	0.188	NR
W16x36	0.62	216	0.092	0.182	NR
W16x40	0.68	197	0.092	0.172	NR
W16x45	0.76	176	0.087	0.159	0.231
W16x50	0.84	159	0.081	0.148	0.216
W16x57	0.95	141	0.074	0.135	0.197
W16x67	0.93	144	0.075	0.138	0.200
W16x77	1.06	126	0.068	0.125	0.182
W16x89	1.22	110	0.060	0.112	0.163
W16x100	1.36	99	0.055	0.102	0.150
W18x35	0.60	223	0.092	0.186	NR
W18x40	0.68	197	0.093	0.172	NR
W18x46	0.78	172	0.085	0.156	0.227
W18x50	0.77	174	0.086	0.158	0.229
W18x55	0.85	158	0.080	0.147	0.214

W18x60	0.92	146	0.075	0.139	0.202
W18x65	0.99	135	0.071	0.131	0.191
W18x71	1.08	124	0.067	0.123	0.179
W18x76	0.96	140	0.073	0.134	0.196
W18x86	1.08	124	0.067	0.123	0.179
W18x97	1.21	111	0.061	0.112	0.164
W18x106	1.32	101	0.057	0.105	0.153
W18x119	1.47	91	0.052	0.096	0.140
W21x44	0.67	200	0.092	0.173	NR
W21x50	0.76	176	0.087	0.159	0.231
W21x57	0.85	158	0.080	0.147	0.214
W21x62	0.85	158	0.080	0.147	0.214
W21x68	0.92	146	0.075	0.139	0.202
W21x72	0.99	135	0.071	0.131	0.191
W21x83	1.12	120	0.065	0.120	0.174
W21x93	1.24	108	0.060	0.110	0.161
W21x101	1.12	120	0.065	0.120	0.174
W21x111	1.23	109	0.060	0.111	0.162
W21x122	1.34	100	0.056	0.104	0.151
W21x132	1.45	92	0.052	0.097	0.142
W21x147	1.60	84	0.048	0.089	0.131
W24x55	0.75	179	0.087	0.160	NR
W24x62	0.84	159	0.081	0.148	0.216
W24x68	0.83	161	0.081	0.149	0.218
W24x76	0.93	144	0.075	0.138	0.200
W24x84	1.02	131	0.070	0.128	0.187
W24x94	1.13	119	0.064	0.119	0.173
W24x104	1.07	125	0.067	0.124	0.181
W24x117	1.20	112	0.061	0.113	0.165
W24x131	1.33	101	0.056	0.104	0.152
W24x146	1.48	91	0.051	0.096	0.140
W24x162	1.63	82	0.047	0.088	0.129
W27x84	0.92	146	0.075	0.139	0.202

W18x60	0.92	146	0.075	0.139	0.202
W18x65	0.99	135	0.071	0.131	0.191
W18x71	1.08	124	0.067	0.123	0.179
W18x76	0.96	140	0.073	0.134	0.196
W18x86	1.08	124	0.067	0.123	0.179
W18x97	1.21	111	0.061	0.112	0.164
W18x106	1.32	101	0.057	0.105	0.153
W18x119	1.47	91	0.052	0.096	0.140
W21x44	0.67	200	0.092	0.173	NR
W21x50	0.76	176	0.087	0.159	0.231
W21x57	0.85	158	0.080	0.147	0.214
W21x62	0.85	158	0.080	0.147	0.214
W21x68	0.92	146	0.075	0.139	0.202
W21x72	0.99	135	0.071	0.131	0.191
W21x83	1.12	120	0.065	0.120	0.174
W21x93	1.24	108	0.060	0.110	0.161
W21x101	1.12	120	0.065	0.120	0.174
W21x111	1.23	109	0.060	0.111	0.162
W21x122	1.34	100	0.056	0.104	0.151
W21x132	1.45	92	0.052	0.097	0.142
W21x147	1.60	84	0.048	0.089	0.131
W24x55	0.75	179	0.087	0.160	NR
W24x62	0.84	159	0.081	0.148	0.216
W24x68	0.83	161	0.081	0.149	0.218
W24x76	0.93	144	0.075	0.138	0.200
W24x84	1.02	131	0.070	0.128	0.187
W24x94	1.13	119	0.064	0.119	0.173
W24x104	1.07	125	0.067	0.124	0.181
W24x117	1.20	112	0.061	0.113	0.165
W24x131	1.33	101	0.056	0.104	0.152
W24x146	1.48	91	0.051	0.096	0.140
W24x162	1.63	82	0.047	0.088	0.129
W27x84	0.92	146	0.075	0.139	0.202

W27x94	1.02	131	0.070	0.128	0.187
W27x102	1.11	121	0.065	0.120	0.176
W27x114	1.23	109	0.060	0.111	0.162
W27x146	1.35	99	0.056	0.103	0.150
W27x161	1.48	91	0.051	0.096	0.140
W27x178	1.63	82	0.047	0.088	0.129
W30x99	1.00	134	0.071	0.130	0.190
W30x108	1.09	123	0.066	0.122	0.178
W30x116	1.16	115	0.063	0.116	0.170
W30x124	1.24	108	0.060	0.110	0.161
W30x132	1.31	102	0.057	0.106	0.154
W30x173	1.46	92	0.052	0.097	0.141
W30x191	1.60	84	0.048	0.089	0.131
W30x211	1.76	76	0.044	0.082	0.121
W33x118	1.08	124	0.067	0.123	0.179
W33x130	1.18	114	0.062	0.115	0.167
W33x141	1.28	105	0.058	0.108	0.157
W33x152	1.37	98	0.055	0.102	0.149
W33x201	1.58	85	0.049	0.090	0.132
W33x221	1.72	78	0.045	0.084	0.123
W33x241	1.88	71	0.042	0.078	0.114
W36x135	1.16	115	0.063	0.116	0.170
W36x150	1.28	105	0.058	0.108	0.157
W36x160	1.36	99	0.055	0.102	0.150
W36x170	1.44	93	0.053	0.098	0.143
W36x182	1.54	87	0.050	0.092	0.135
W36x194	1.63	82	0.047	0.088	0.129
W36x210	1.76	76	0.044	0.082	0.121
W36x230	1.71	78	0.045	0.085	0.124
W36x245	1.82	74	0.043	0.080	0.117
W36x260	1.92	70	0.041	0.076	0.112
W36x280	2.06	65	0.038	0.072	0.105
W36x300	2.19	61	0.036	0.068	0.100

NR-Not Rated

CARBOLINE CO — Type Nullifire S606. Investigated for Interior Conditioned Space Purpose.

*Bearing the UL Classification Marking

254363003

Fire Resistance Ratings - ANSI/UL 263

Design No. X633

November 30, 1999

Ratings — 1 and 1-1/2 Hr. (See Item 2)

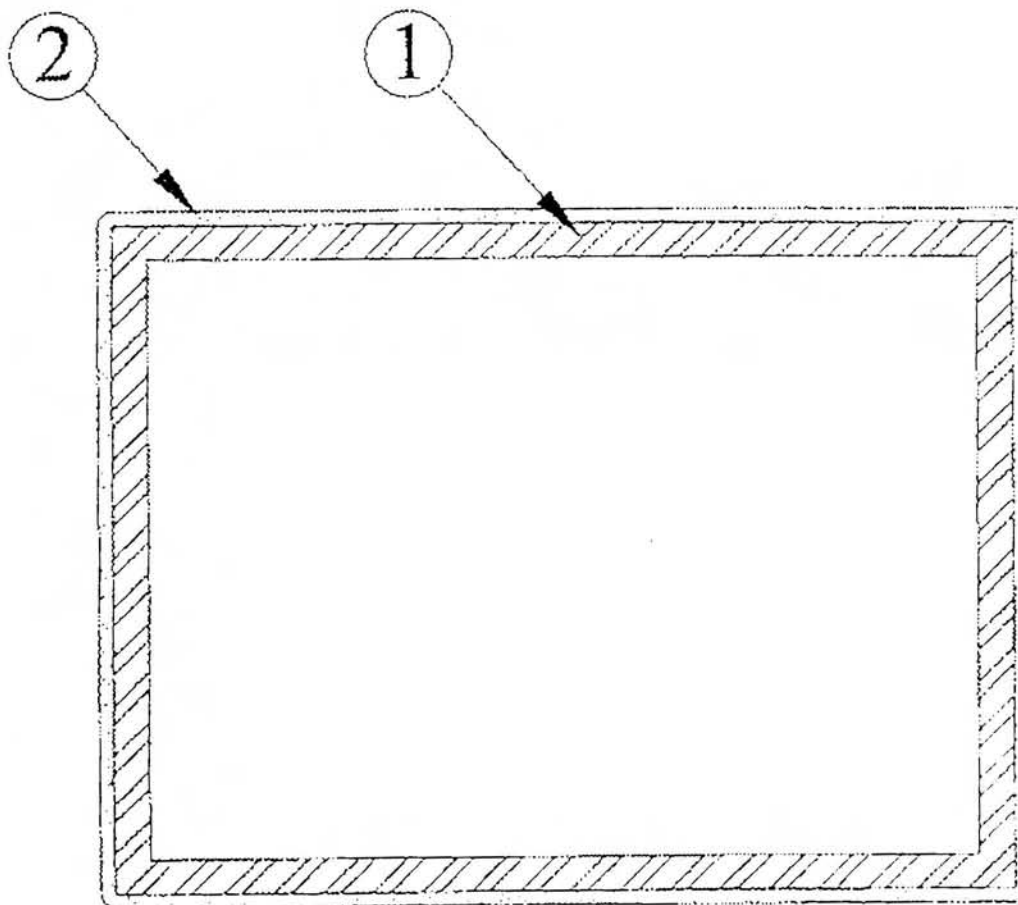

1. **Steel Column** Steel tube columns with the minimum sizes shown in the tables below. Columns shall be free of dirt, loose scale and oil. Column shall be primed with a red oxide zinc phosphate primer.

2. **Mastic Coating** Coating spray, brush or trowel applied directly from containers to desired thickness. See table below for appropriate final dry thickness.

SIZE	A/P	1 HR	1-1/2 HR
ST 3X3X5/16	0.28	0.123	NR
ST 3.5X3.5X5/16	0.28	0.123	NR
ST 4X4X5/16	0.29	0.122	NR
ST 4X4X3/8	0.34	0.107	NR
ST 4X4X1/2	0.44	0.078	0.165
ST 5X5X5/16	0.29	0.120	NR
ST 5X5X3/8	0.35	0.105	NR
ST 5X5X1/2	0.45	0.075	0.161
ST 6X6X5/16	0.30	0.119	NR
ST 6X6X3/8	0.35	0.103	NR
ST 6X6X1/2	0.46	0.072	0.157
ST 7X7X5/16	0.30	0.118	NR
ST 7X7X1/2	0.46	0.071	0.155
ST 7X7X3/8	0.35	0.102	NR
ST 8X8X5/16	0.30	0.118	NR
ST 8X8X3/8	0.36	0.102	NR
ST 8X8X1/2	0.47	0.069	0.153
ST 8X8X5/8	0.58	0.038	0.108
ST 10X10X5/16	0.30	0.118	NR
ST 10X10X3/8	0.36	0.101	NR
ST 10X10X1/2	0.48	0.067	0.150
ST 10X10X5/8	0.59	0.035	0.104
ST 12X12X5/16	0.30	0.118	NR
ST 12X12X3/8	0.36	0.100	NR
ST 12X12X1/2	0.48	0.066	0.149
ST 14X14X5/16	0.31	0.117	NR
ST 14X14X3/8	0.36	0.099	NR
ST 14X14X1/2	0.48	0.065	0.147
ST 16X16X5/16	0.31	0.116	NR
ST 16X16X3/8	0.37	0.099	NR
ST 16X16X1/2	0.48	0.065	0.146
ST 4X3X5/16	0.28	0.123	NR

ST 5X3X15/16	0.29	0.122	NR
ST 5X3X3/8	0.34	0.107	NR
ST 5X3X1/2	0.44	0.078	0.166
ST 5X4X5/16	0.29	0.121	NR
ST 5X4X3/8	0.34	0.106	NR
ST 6X3X5/16	0.29	0.121	NR
ST 6X3X3/8	0.34	0.106	NR
ST 6X4X5/16	0.29	0.120	NR
ST 6X4X3/8	0.35	0.105	NR
ST 6X4X1/2	0.45	0.075	0.161
ST 7X3X5/16	0.29	0.120	NR
ST 7X3X3/8	0.35	0.105	NR
ST 7X4X5/16	0.29	0.120	NR
ST 7X4X3/8	0.35	0.104	NR
ST 7X5X5/16	0.30	0.119	NR
ST 7X5X3/8	0.35	0.103	NR
ST 7X5X1/2	0.46	0.072	0.157
ST 8X3X5/16	0.29	0.120	NR
ST 8X3X3/8	0.35	0.104	NR
ST 8X4X5/16	0.30	0.119	NR
ST 8X4X3/8	0.35	0.103	NR
ST 8X4X1/2	0.46	0.072	0.157
ST 8X6X5/16	0.30	0.119	NR
ST 8X6X3/8	0.35	0.102	NR
ST 8X6X1/2	0.46	0.071	0.155
ST 10X4X5/16	0.30	0.118	NR
ST 10X4X3/8	0.35	0.102	NR
ST 10X4X1/2	0.46	0.071	0.155
ST 10X6X5/16	0.30	0.118	NR
ST 10X6X3/8	0.36	0.102	NR
ST 10X6X1/2	0.47	0.069	0.153
ST 12X4X5/16	0.30	0.118	NR
ST 12X4X3/8	0.36	0.102	NR

ST 12X4X1/2	0.47	0.069	0.153
ST 12X6X1/4	0.24	0.135	NR
ST 12X6X5/16	0.30	0.118	NR
ST 12X6X3/8	0.36	0.101	NR
ST 12X6X1/2	0.47	0.068	0.152
ST 12X8X5/16	0.30	0.035	NR
ST 12X8X3/8	0.36	0.101	NR
ST 12X8X1/2	0.48	0.067	0.150
ST 12X8X5/8	0.59	0.035	0.104
ST 14X4X5/16	0.30	0.118	NR
ST 14X4X3/8	0.36	0.101	NR
ST 14X4X1/2	0.47	0.068	0.152
ST 14X6X5/16	0.30	0.118	NR
ST 14X6X3/8	0.36	0.101	NR
ST 14X6X1/2	0.48	0.067	0.150
ST 14X10X5/16	0.30	0.117	NR
ST 14X10X3/8	0.36	0.100	NR
ST 14X10X1/2	0.48	0.066	0.149
ST 16X4X5/16	0.30	0.118	NR
ST 16X4X3/8	0.36	0.101	NR
ST 16X4X1/2	0.48	0.067	0.150
ST 16X8X5/16	0.30	0.118	NR
ST 16X8X3/8	0.36	0.100	NR
ST 16X8X1/2	0.48	0.066	0.149
ST 16X12X5/16	0.31	0.118	NR
ST 16X12X3/8	0.36	0.099	NR
ST 16X12X1/2	0.48	0.065	0.150
ST 16X12X5/8	0.60	0.050	0.098

NR-Not Rated

CARBOLINE CO — Type Nullifire S606. Investigated for Interior Conditioned Space Purpose.

*Bearing the UL Classification Marking

Fire Resistance Ratings - ANSI/UL 263

Design No. X634

November 30, 1999

Ratings — 1 and 1-1/2 Hr (See Item 2)

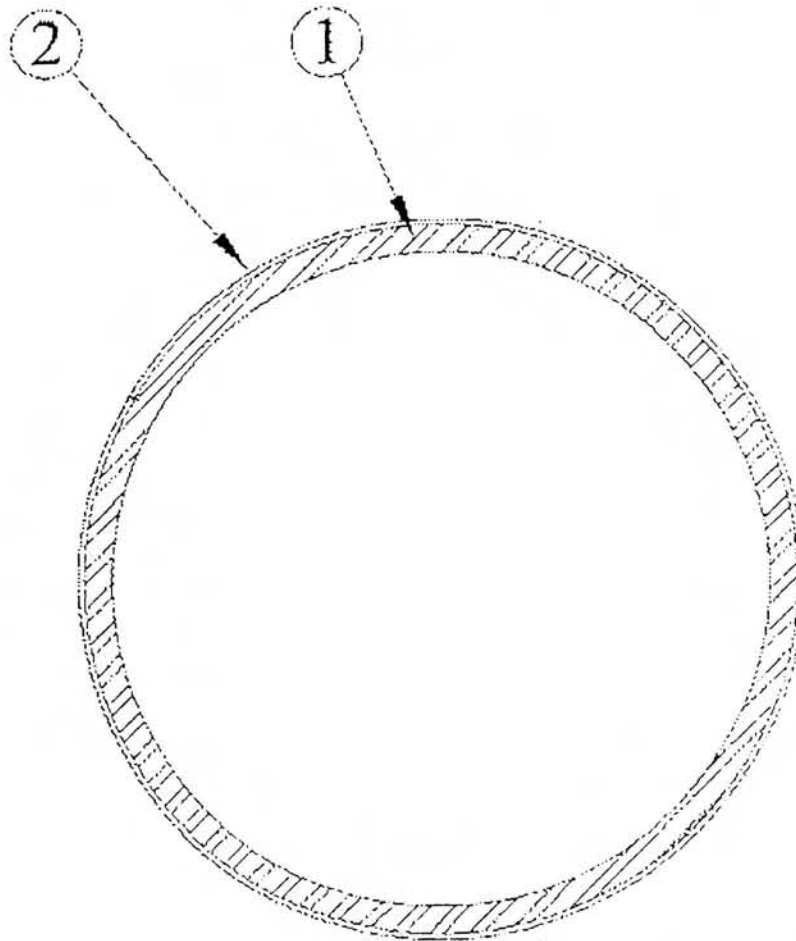

1. **Steel Column** Steel pipe columns with the minimum sizes shown in the tables below. Columns shall be free of dirt, loose scale and oil. Column shall be primed with a red oxide zinc phosphate primer.

2. **Mastic Coating** Coating spray, brush or trowel applied directly from containers to desired thickness. See table below for appropriate final dry thickness.

SIZE	A/P	1 HR	1-1/2 HR
SP 3X0.6	0.50	0.061	0.141
SP 3.5X0.318	0.29	0.120	NR
SP 4X0.337	0.31	0.115	NR
SP 4X0.674	0.57	0.050	0.109
SP 5X0.375	0.35	0.104	NR
SP 6X0.432	0.40	0.088	NR
SP 8X0.322	0.31	0.115	NR
SP 8X0.5	0.47	0.069	0.152
SP 10X0.365	0.35	0.103	NR
SP 10X0.365	0.35	0.103	NR
SP 12X0.375	0.36	0.100	NR
SP 12X0.5	0.48	0.066	0.148

NR-Not Rated

CARBOLINE CO — Type Nullifire S606. Investigated for Interior Conditioned Space Purpose.

*Bearing the UL Classification Markir

254363003

Recommendation - That the above described assemblies be accepted for Class II Buildings only, as having the fire resistance ratings given above, when members framing into the columns have at least the same fire resistance rating, provided that following requirements for application and protection of the mastic coating fireproofing be adhered to:

1. Where used for protection of floor ceiling and/or assemblies in roof/ceiling in fireproof buildings each such assembly shall bear an identifying tag installed at each beam. Subject tag shall be of metal construction mechanically attached to such beams and shall state the following: "this beam has been fireproofed with MEA approved Nullifire finish and such finish shall not be removed" nor any subsequent coating shall be applied other than Nullifire.
2. The general contractor and the owner shall provide qualified personnel to supervise the application of the sprayed-on fireproofing. They shall certify to the Department of Buildings that the finished fireproofing of the completed building is in full compliance with the acceptance requirements and drawings approved by the Department of Buildings.
3. The installation of the sprayed on fire protection shall be subject to the controlled inspection requirements of Section 27-132.
4. The use of this material shall be subject to all pertinent regulations of the Department of Air Resources and the Department of Health.
5. All installations shall comply with 118-68 GR, the New York City Building Code, the Fire Department Directives, the manufacturer's instructions and laboratory recommendation.
6. All shipments and deliveries of the materials comprising this assembly shall be accompanied by a certificate or label certifying that the materials shipped or delivered are equivalent to those tested and acceptable for use, as provided for in Section 27-131 of the Building Code.

Final Acceptance JUL 27 2000
Examined by S. Derk Hudom