

CITY OF NEW YORK
DEPARTMENT OF BUILDINGS

Pursuant to Administrative Code Section 27-131, the following equipment of material has been found acceptable for use in accordance with the Report of the Material and Equipment Acceptance (MEA) division.

Patricia J. Lancaster, AIA., Commissioner

MEA 262-03-E

Report of Material and Equipment Acceptance Division

Manufacturer - SpaceJoist TE, 1101 N. Great Southwest Parkway. Arlington, TX 76011.

Trade Name- SpaceJoist TE™.

Product-Trimable Parallel Chord Trusses.

Pertinent Code Section(s) – 27-617 through 27-624.

Tests – ASTM D-5055; I-joist end capacity and failure mode with a variety of different end trimmed conditions. Performed in accordance with ASTM D 5055 Section 6.3.3.1.

ER-1607; Metal Connector Plates Model 20, TW18 and TW16, Lateral Resistance, Tension Resistance, Shear Resistance, Metal Plate Reductions, Combined Shear and Tension, Combined Flexure and Axial Loading. Performed in accordance with National Design Standard for Metal Plate Connected Wood Truss Construction, ANSI/TPI 1-1995.

ER-3687; SpaceJoist Webs, Installation, Truss Fabrication, Truss Design, and Identification. Performed in accordance with TPI QST-85.

Laboratory – PFS, 2402 Daniels Street, Madison, WI 53718.
ICC Evaluation Service, Inc., 5360 Workman Mill Road, Whittier, California 90601.

Design Properties and Allowable Floor Spans - certified by Gary T. Obudzinski P.E., New York State License Number 080381.

Test Reports – PFS TEST REPORT # 02-92, I-joist End Qualification Tests SpaceJoist TE 14-320/420. SpaceJoist TE 16-320/420. ICC Evaluation Test Report ER-1607, Metal Connector Plate SpaceJoist Models #20, TW18 and TW 16. ICC Evaluation Test Report ER-3687 SpaceJoist Webs Installation and Design.

Description- SpaceJoist TE 320 and 420 series are Prefabricated Trimmable Parallel Chord Floor Trusses. Each truss is manufactured with an I-joist end, in accordance with ASTM D5055 and is trimmable by 12 inches on each end of the truss. The flange or chord material consists of 3x2 inch or 4x2 inch MSR (machine stress rated) PSF (pine, spruce, or fir lumber). The Patented SpaceJoist Metal webs are installed in pairs and are installed in accordance to ANSI/TPI 1-1995 referenced in "ICC's International Building Code 2000" Section 2303.4. The SpaceJoist Metal webs are 20-gage ASTM A 653 Grade 37 structural quality steel with a hot-dipped galvanized zinc coating designated G60. The OSB web material is structural OSB stamped with APA certification and Exposure 1 designation and has a thickness of 15/32" and are stamped with the 32/16 span rating and is manufactured in accordance with PS2-92 or PRP-108 specification. The top and bottom flanges are parallel forming a constant depth joist with a camber of 1/8" per ten feet. This product has been tested and assigned design values for use in structural applications.

The glue used in the manufacturing process of SpaceJoist TE is Borden Cascophen LT-5210D with hardeners Cascoset FM-7340 or FM-7400 and they are defined as thermosetting. This means that, in addition to passing a stringent Durability Standard called ASTM D 2559, once they are cured to a hard substance during the manufacturing process, they do not soften or relax when subsequently exposed to elevated temperatures. In other words, the wood will burn at temperatures much lower than the char-point of Borden Cascophen LT-5210D with hardeners Cascoset FM-7340 or FM-7400. It is also pertinent to note that phenol, resorcinol, formaldehyde adhesives such as LT-5210D with FM-7340 or FM-7400 do not lower the combustion point of wood composites or increase the amount of smoke produced as a consequence of such combustion. One final point: burned, charred, or ashed PRF adhesive releases the same combustion by-products as wood itself. There is no toxicity associated with charring, burning, or ashing of Borden Cascophen LT-5210D with hardeners Cascoset FM-7340 or FM-7400.

Recommendation- That the above SpaceJoist TE Joists be accepted on condition that all uses, locations and installations shall comply with the applicable requirements of New York City Building Code and Technical Policy and Procedure Notice #8, 1992 (attached), TPPN #2, 2000 dated July 24, 2000 (attached) and on further condition that:

1. All provisions of TPPN #8, 1992 and TPPN #2, 2000 for SpaceJoist TE Joists that are applicable shall be complied with.
2. Structure designs using the SpaceJoist TE Joists shall conform to the manufacturer's specifications except that appropriate design load(s), deflection, limitation(s) and other performance standards of the New York Building Code shall apply.

3. The glue used shall not delaminate using a fire.
4. SpaceJoist TE Joists shall be used indoors.
5. When stored out-of-doors, or exposed to wet weather conditions, during construction SpaceJoist TE Joists shall be inspected by the user for flange-web separation, swelling or warping and replaced if so damaged.
6. The size and location of any cutouts in the web of the joist shall not exceed the manufacturer's recommendations and shall be subject to controlled inspection.
7. The SpaceJoist TE Joist flanges may not be cut, notched or bored.
8. Fire-stopping shall be provided between the ceiling and the floor or roof above and shall be divided into approximately equal areas not greater than 500 square feet.
9. The building permit applicant shall notify the Fire Department of the proposed installation of SpaceJoist TE Joists prior to the Building Department issuance of a construction permit. Evidence of such notification shall be a certifying statement submitted on form TR-1, Technical Report, reading as follows:

I hereby state that I have mailed a copy of the statement to the Fire Department, Bureau of Fire Prevention, Technology Management Unit, as notification of the proposed installation of Parallel Chord Floor Trusses at this location.

This statement shall be placed on the reverse side of the form in the lower right-hand box.

The copy of the completed form TR-1 shall be mailed to the new address at:

Chief-In-Charge of the Bureau of Fire Prevention
 Fire Department
 Bureau of Fire Prevention
 Technology Management Unit
 9 MetroTech Center
 Brooklyn, New York 11201-3857.

All Shipments and deliveries of SpaceJoist TE Joists shall be provided with a permanent marking suitably placed, certifying that the materials shipped or delivered is equivalent to those tested and accepted for use, as provided for in Section 27-131 of the Building Code.

Final Acceptance

Accepted 3/1/2003

Examined by

Arnold X [Signature]



DEPARTMENT OF BUILDINGS

EXECUTIVE OFFICES
60 HUDSON STREET, NEW YORK, N.Y. 10014

RUDOLPH W. RINALDI, Commissioner

TEL: 878-0000

RICHARD C. VISCONTI, A.I.A.
Assistant Commissioner
Technical Affairs

TECHNICAL
POLICY AND PROCEDURE NOTICE # 8/92

TO: Distribution

FROM: Richard C. Visconti, A.I.A. *Richard Visconti*

DATE: August 19, 1992

SUBJECT: Laminated Wood "I" Beams

PURPOSE: To interpret the requirements of the Administrative Code, Sections 27-617 and 27-620, pertaining to firestopping requirements per RS 10-8 and Inspection of Methods of Construction per Table 10-2 for laminated wood "I" beams used in fire resistance rated floor/roof-ceiling assemblies.

To establish a new administrative procedure for applicant notification to the Fire Department of proposed use of laminated wood "I" beams.

SPECIFICS:

1. Firestopping

Reference Standard RS 10-8, Section 9.2.1 - General Requirements for Firestopping states that, "the space between the ceiling and the floor or roof above shall be divided by providing firestopping where ceilings are suspended below solid joists or suspended from or attached directly to the bottom of open wood floor trusses in buildings of combustible construction."

The Department now interprets the requirement to comply with the firestopping provisions of Section 9.2.1 et seq. to include laminated wood "I" beam assemblies. Therefore, the space between the ceiling and the floor or roof above shall be divided into approximately equal areas of not more than 500 square feet.

Firestopping is subject to controlled inspection pursuant to Section 27-345.

2. Inspection of Methods of Construction

Table 10-2 - Operations on Structural Elements that shall be subject to Controlled Inspection, lists the "Fabrication of glue-laminated assemblies and of plywood components."

The Department now interprets the requirement to comply with the controlled inspection provision of Table 10-2 to include laminated wood "I" beams. Therefore, the cutting of openings for ducts, pipes, conduit, etc. in laminated wood "I" beams shall be considered fabrication and, therefore, subject to controlled inspection.

3. Notification

The applicant shall be required to notify the Fire Department of the proposed installation of laminated wood "I" beams prior to the Department issuing a construction permit. Evidence of such notification shall be a certifying statement submitted on Form TR-1, Technical Report, reading as follows:

I hereby state that I have mailed a copy of this statement to the Fire Department, Bureau of Fire Prevention, Technology Management Unit, as notification of the proposed installation of laminated wood "I" beams at this location.

This statement shall be placed on the reverse side of the form in the lower right-hand box.

The copy of the completed Form TR-1 shall be mailed to:

Chief-in-Charge of the Bureau of Fire Prevention
Fire Department
Bureau of Fire Prevention
Technology Management Unit
250 Livingston Street
Brooklyn, NY 11201-5884

cc: Chief John Hodgens



DEPARTMENT OF BUILDINGS

EXECUTIVE OFFICES

61 HUDSON STREET, NEW YORK, N.Y. 10011-1194

RICHARD C. VISCONTI, R.A., Acting Commissioner

Website: nyclink.org/buildings

(212) 312-8000

TTY (212) 312-3153

SATISH K. BABBAR, R.A.

Acting Deputy Commissioner

Technical Affairs

(212) 312-8324

Fax (212) 312-8319

ISSUANCE #586

TECHNICAL
POLICY AND PROCEDURE NOTICE #2/00

TO: Distribution
FROM: Satish K. Babbar, R.A. 
DATE: July 24, 2000
SUBJECT: Semi-Controlled Inspection for Structural Light Gage Cold-Formed Steel,
Plate Connected Wood Floor Trusses and Laminated Wood "I" Beams

EFFECTIVE: Immediately

SUPERCEDES: Brooklyn Borough Memorandum by Borough Superintendent George E. Berger dated August 11, 1983.

BACKGROUND: There have been several structural failures involving lightweight floor construction. Professional inspection is needed during construction of buildings and other structures utilizing it in order to insure that the delivered members are not damaged or defective, the installation is proper and safeguards are taken to prevent failure.

PURPOSE: To set forth the requirements for the semi-controlled inspection of the construction, including size, quality, framing, erection and both temporary and permanent bracing of light gage cold-formed steel structural members, plate connected wood floor trusses and laminated wood "I" beams.

REFERENCE: Section 27-132(b) of the Administrative Code.

SPECIFICS:

REQUIREMENTS: The plans submitted for approval/acceptance/professional certification showing these members shall be complete including member sizes, positions, locations, permanent and temporary bracing, fasteners (location, type and spacing), stiffeners, connections, etc., as needed for the proper erection of the structure.

The construction of all light gage cold-formed steel structural members, plate connected wood floor trusses and laminated wood "I" beams shall be subject to semi-controlled inspection for size, quality, framing, erection and both temporary and permanent bracing, as set forth below.

- Size** Profiles used structurally shall conform to the specified dimension. Care shall be taken not to stretch, bend, or otherwise distort parts of the sections unless such forming is in the integral part of the design.
- Quality** All materials shall be clean, straight, and undamaged. Damaged members shall be discarded. Only BSA/MEA approved laminated wood "I" beams shall be used. Glue shall completely bond all laminated wood "I" beam surfaces being joined. Quality Control for the erection of all members shall be under the supervision of the professional designated to perform the semi-controlled inspection.
- Framing** Components may be cut by slitting, shearing, sawing, or flame cutting, as appropriate, in accordance with manufacturers' instructions and the design drawings. All punched holes and sheared or flame cut edges of material in members subject to calculated stress shall be clean and free from notches and burred edges. The approved/accepted/professionally certified drawings shall be adhered to regarding member dimensions, locations, positions, beam separators, bearing surfaces and fasteners, including shear connectors, plate connectors, screws, bolts and welds, as applicable.

Erection Care shall be taken to avoid damage to members when erecting, loading, unloading and otherwise handling them.

Bracing Temporary bracing, shoring, jacks, etc. shall not be removed until the registered architect or professional engineer determines that they are no longer needed. Permanent bracing, web stiffeners, bridging, wind bracing, etc. shall be installed according to the approved/accepted/professionally certified drawings.

INSPECTIONS AND REPORT TO BE SUBMITTED: These inspections are to be performed by, or under the direct supervision of, licensed professional engineers or registered architects, who shall submit form(s) TR-1 indicating the following: "Semi-controlled inspection of light gauge cold-formed steel structural members, plate connected wood floor trusses or laminated wood "I" beams (as applicable) per-TPPN #2/00".

SKB:NJG:ng

TOP CHORD 3X2 SPF CAN. 1650F-1.5E
 BOTTOM CHORD 3X2 SPF CAN. 1650F-1.5E
 LUMBER SHEAR ALLOWABLES ARE PER NDS-1997

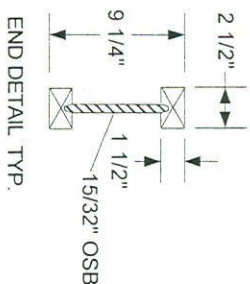

LOADING, PSF	9 1/4" SPACEJOIST TE MAXIMUM SPANS			
	DEFLECTION RATIO	SPACING		
40-10-5	L/480	24" o.c.	19.2" o.c.	16" o.c.
	L/360	14'-3"	14'-10"	16'-1"
40-20-5	L/480	15'-8"	16'-7"	17'-9"
	L/360	13'-7"	14'-9"	16'-0"
		13'-7"	16'-3"	17'-9"
				18'-0"

THIS TRUSS IS TRIMMABLE
 UP TO 12" MAY BE FIELD-TRIMMED
 FROM EACH END OF THIS TRUSS

SEE TX96284011-001 FOR SPACEJOIST TE
 ASSEMBLY AND GENERAL NOTES

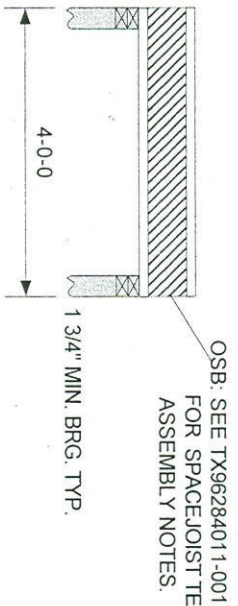

NOV 13 2003

DATE: 01/14/03

Designed by Truswal Systems



ALL WEBS ARE 20 GAUGE SPACEJOIST METAL WEBS MANUFACTURED BY TRUSWAL SYSTEMS CORPORATION.

WARNING Read all notes on this sheet and give a copy of it to the Erecting Contractor.

This design is for an individual building component, not a truss system. It has been based on specifications provided by the component manufacturer and has been completed in accordance with the current versions of TPI and AFPA design standards. No responsibility is assumed for dimensional accuracy.

Dimensions are to be verified by the component manufacturer and/or building designer prior to fabrication. The building designer shall ascertain that the loads utilized on this design meet or exceed the loading imposed by the local building code and the particular application. This design assumes that the top chord is laterally braced by the roof or floor sheathing and that the bottom chord is laterally braced by a rigid sheathing material directly attached, unless otherwise noted. Bracing shown is for lateral support of individual component members only. This component shall not be placed in any environment that will cause the moisture content of the wood to exceed 19% and/or cause connector plate corrosion. Fabricate, handle, install, and brace this truss in accordance with the following standards: SPACEJOIST TRUSS FABRICATION MANUAL, by Truswal Systems; Handling, Installing, and Bracing Metal Plate Connected Wood Trusses (HLB 91 and HLB-91 Summary Sheet) by TPI. The Truss Plate Institute is located at 583 D'Onofrio Dr., Ste. 200, Madison, WI 53719. The American Forest and Paper Association (AFPA) is located at 1111 19th St. N.W., Ste. 800, Washington, DC 20036.

Customer Name: SpaceJoist TE

TC Live 40 psf
 TC Dead See Span Table
 BC Live 0 psf
 BC Dead 5 psf
 DurFacts: L = 1.00 P = 1.00
 Rep Mbr Bnd: 1.15
 Spacing: See Span Table
 Design Spec: TPI

Trimable End

SpaceJoist™

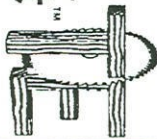

1101 North Great Southwest Parkway
 Arlington, Texas 76011

TOP CHORD 3X2 SPF CAN. 1650F-1.5E
 BOTTOM CHORD 3X2 SPF CAN. 1650F-1.5E
 LUMBER SHEAR ALLOWABLES ARE PER NDS-1997

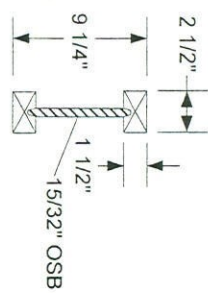

END DETAIL TYP.



THIS TRUSS IS TRIMMABLE
 UP TO 18" MAY BE FIELD-TRIMMED
 FROM EACH END OF THIS TRUSS

SEE TX96284011-001 FOR SPACEJOIST TE
 ASSEMBLY AND GENERAL NOTES

LOADING, PSF	9 1/4" SPACEJOIST TE MAXIMUM SPANS		
	DEFLECTION RATIO	SPACING	
40-10-5	L/480	24" o.c.	16" o.c.
	L/360	19.2" o.c.	12" o.c.
40-20-5	L/480	14'-3"	16'-1"
	L/360	15'-8"	17'-9"
40-20-5	L/480	13'-7"	16'-0"
	L/360	13'-7"	17'-9"
40-20-5	L/480	16'-3"	17'-9"
	L/360	16'-3"	18'-0"

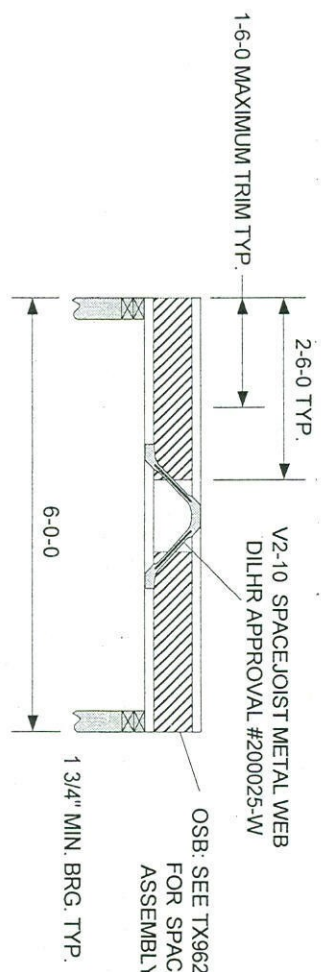

ALL WEBS ARE 20 GAUGE SPACEJOIST METAL WEBS MANUFACTURED BY TRUSSAL SYSTEMS CORPORATION.

WARNING Read all notes on this sheet and give a copy of it to the Erecting Contractor.

This design is for an individual building component, not a truss system. It has been based on specifications provided by the component manufacturer and has been completed in accordance with the current versions of TPI and AFPA design standards. No responsibility is assumed for dimensional accuracy. Dimensions are to be verified by the component manufacturer and/or building designer prior to fabrication. The building designer shall ascertain that the loads utilized on this design meet or exceed the loading imposed by the local building code and the particular application. This design assumes that the top chord is laterally braced by the roof or floor sheathing and that the bottom chord is laterally braced by a rigid sheathing material directly attached, unless otherwise noted. Bracing shown is for lateral support of individual component members only. This component shall not be placed in any environment that will cause the moisture content of the wood to exceed 19% and/or cause connector plate corrosion. Fabricate, handle, install, and brace this truss in accordance with the following standards: SPACEJOIST TRUSS FABRICATION MANUAL, by Trussal Systems; Handling, Installing, and Bracing Metal Plate Connected Wood Trusses (HB-91 and HB-91 Summary Sheet) by TPI; The Truss Plate Institute is located at 583 D'Onofrio Dr., Ste. 200, Madison, WI 53719; The American Forest and Paper Association (AFPA) is located at 1111 19th St. N.W., Ste. 800, Washington, DC 20038.

Trimmable End
SpaceJoist™
 1101 North Great Southwest Parkway
 Arlington, Texas 76011



NOV 19 2003

DATE: 01/14/03
 Designed by Trussal Systems

CHK:	Customer Name:
Dsgnr: DL	SpaceJoist TE
TC Live 40 psf	DurFacs: L= 1.00 P= 1.00
TC Dead See Span Table	Rep Mbr End: 1.15
BC Live 0 psf	Spacing: See Span Table
BC Dead 5 psf	Design Spec: TPI
TOTAL See Span Table	

TOP CHORD 3X2 SPF CAN. 1650F-1.5E
 BOTTOM CHORD 3X2 SPF CAN. 1650F-1.5E
 LUMBER SHEAR ALLOWABLES ARE PER NDS-1997

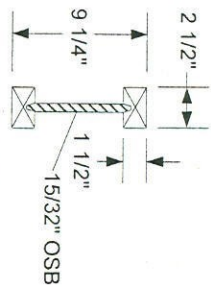

END DETAIL, TYP.

THIS TRUSS IS TRIMMABLE
 UP TO 12" MAY BE FIELD-TRIMMED
 FROM EACH END OF THIS TRUSS

SEE TX96284011-001 FOR SPACEJOIST TE
 ASSEMBLY AND GENERAL NOTES

LOADING, PSF	9 1/4" SPACEJOIST TE MAXIMUM SPANS		
	DEFLECTION RATIO	SPACING	
40-10-5	L/480	24" O.C.	12" O.C.
	L/360	19.2" O.C.	16" O.C.
40-20-5	L/480	14'-3"	16'-1"
	L/360	15'-8"	17'-9"
40-20-5	L/480	13'-7"	16'-0"
	L/360	13'-7"	17'-9"
40-20-5	L/480	16'-3"	18'-0"
	L/360	16'-3"	18'-0"

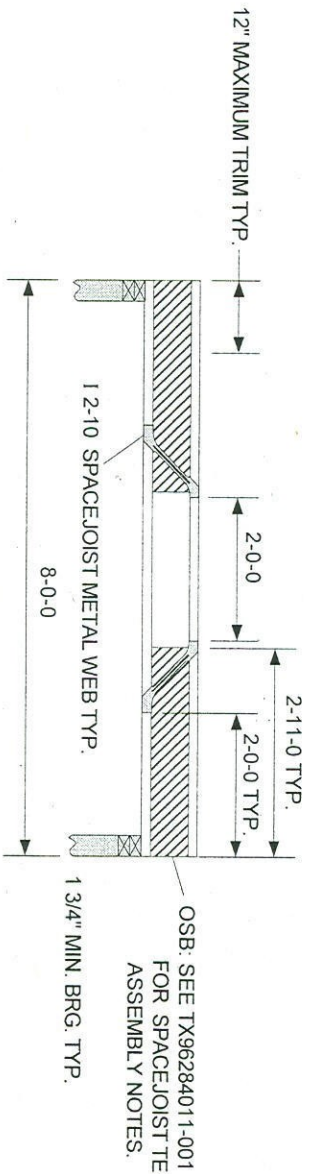

OSB: SEE TX96284011-001
 FOR SPACEJOIST TE
 ASSEMBLY NOTES.

ALL WEBS ARE 20 GAUGE SPACEJOIST METAL WEBS MANUFACTURED BY TRUSWAL SYSTEMS CORPORATION.

WARNING Read all notes on this sheet and give a copy of it to the Erecting Contractor.

This design is for an individual building component, not a truss system. It has been based on specifications provided by the component manufacturer and has been completed in accordance with the current versions of TPI and AFPA design standards. No responsibility is assumed for dimensional accuracy. Dimensions are to be verified by the component manufacturer and/or building designer prior to fabrication. The building designer shall ascertain that the loads utilized on this design meet or exceed the loading imposed by the local building code and the particular application. This design assumes that the top chord is laterally braced by the roof or floor sheathing and that the bottom chord is laterally braced by a rigid sheathing material directly attached, unless otherwise noted. Bracing shown is for lateral support of individual component members only. This component shall not be placed in any environment that will cause the moisture content of the wood to exceed 19% and/or cause connector plate corrosion. Fabricate, handle, install, and brace this truss in accordance with the following standards: SPACEJOIST TRUSS FABRICATION MANUAL, by Truswal Systems; Handling, Installing, and Bracing Metal Plate Connected Wood Trusses (HIB-91 and HIB-91 Summary Sheet) by TPI, The Truss Plate Institute is located at 683 D'Orofino Dr., Ste. 200, Madison, WI 53719; The American Forest and Paper Association (AFPA) is located at 1111 19th St. N.W., Ste. 800, Washington, DC 20036.

CHK:	Customer Name:
Dsgnr: DL	SpaceJoist TE
TC Live	DurFacs: L= 1.00 P= 1.00
TC Dead	Rep Mbr Bnd: 1.15
BC Live	Spacing: See Span Table
BC Dead	Design Spec: TPI
TOTAL	See Span Table



1101 North Great Southwest Parkway
 Arlington, Texas 76011



NOV 19 2003

DATE: 01/14/03

Designed by Truswal Systems

TOP CHORD 3X2 SPF CAN. 1650F-1.5E
 BOTTOM CHORD 3X2 SPF CAN. 1650F-1.5E
 LUMBER SHEAR ALLOWABLES ARE PER NDS-1997

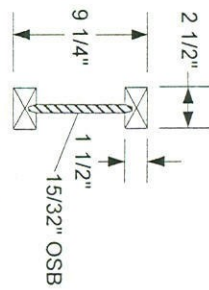

END DETAIL TYP.



THIS TRUSS IS TRIMMABLE
 UP TO 12" MAY BE FIELD-TRIMMED
 FROM EACH END OF THIS TRUSS

SEE TX96284011-001 FOR SPACEJOIST TE
 ASSEMBLY AND GENERAL NOTES

LOADING, PSF	9 1/4" SPACEJOIST TE MAXIMUM SPANS			
	DEFLECTION RATIO	SPACING		
40-10-5	L/480	24" O.C.	19.2" O.C.	16" O.C.
	L/360	14'-3"	14'-10"	16'-1"
40-20-5	L/480	15'-8"	16'-7"	17'-9"
	L/360	13'-7"	14'-9"	16'-0"
		13'-7"	16'-3"	17'-9"
				18'-0"

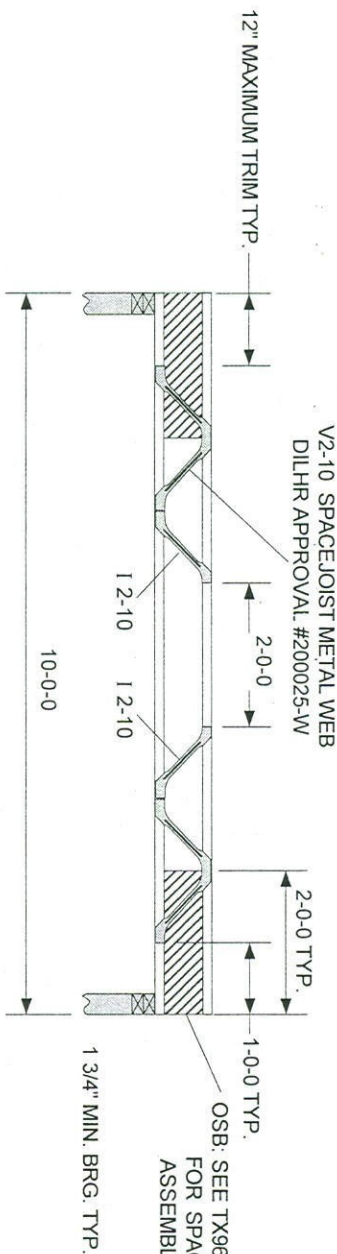

OSB: SEE TX96284011-001
 FOR SPACEJOIST TE
 ASSEMBLY NOTES.

NOV 13 2003

DATE: 01/14/03

Designed by Trussal Systems

ALL WEBS ARE 20 GAUGE SPACEJOIST METAL WEBS MANUFACTURED BY TRUSSAL SYSTEMS CORPORATION.

WARNING Read all notes on this sheet and give a copy of it to the Erecting Contractor.

This design is for an individual building component, not a truss system. It has been based on specifications provided by the component manufacturer and has been completed in accordance with the current versions of TPI and AFPA design standards. No responsibility is assumed for dimensional accuracy. Dimensions are to be verified by the component manufacturer and/or building designer prior to fabrication. The building designer shall ascertain that the loads utilized on this design meet or exceed the loading imposed by the local building code and the particular application. This design assumes that the top chord is laterally braced by the roof or floor sheathing and that the bottom chord is laterally braced by a rigid sheathing material directly attached, unless otherwise noted. Bracing shown is for lateral support of individual component members only. This component shall not be placed in any environment that will cause the moisture content of the wood to exceed 19% and/or cause connector plate corrosion. Fabricate, handle, install, and brace this truss in accordance with the following standards: SPACEJOIST TRUSS FABRICATION MANUAL, by Trussal Systems; Handling, Installing, and Bracing Metal Plate Connected Wood Trusses (HIB-91 and HIB-91 Summary Sheet) by TPI. The Truss Plate Institute is located at 583 D'Orofino Dr., Ste. 200, Madison, WI 53719. The American Forest and Paper Association (AFPA) is located at 1111 19th St. N.W., Ste. 800, Washington, DC 20036.

Trimable End

SpaceJoist™

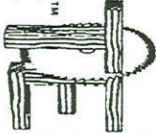

1101 North Great Southwest Parkway
 Arlington, Texas 76011

CHK:		Customer Name:	SpaceJoist TE
Dsgnr: DL		TC Live	40 psf
		TC Dead	See Span Table
		BC Live	0 psf
		BC Dead	5 psf
		TOTAL	See Span Table
		DurFacts:	L = 1.00 P = 1.00
		Rep Mbr Bnd:	1.15
		Spacing:	See Span Table
		Design Spec:	TPI

TOP CHORD 3X2 SPF CAN 1650F-1.5E
 BOTTOM CHORD 3X2 SPF CAN 1650F-1.5E
 LUMBER SHEAR ALLOWABLES ARE PER NDS-1997

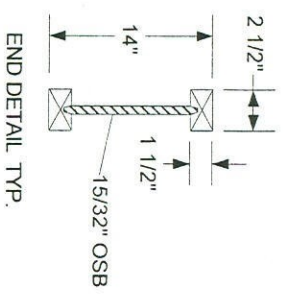

THIS TRUSS IS TRIMMABLE
 UP TO 12" MAY BE FIELD-TRIMMED
 FROM EACH END OF THIS TRUSS

SEE TX96284011-001 FOR SPACEJOIST TE
 ASSEMBLY AND GENERAL NOTES

LOADING, PSF	14" SPACEJOIST TE MAXIMUM SPANS					
	DEFLECTION RATIO	SPACING				
40-10-5	L/480	24" o.c.	19.2" o.c.	16" o.c.	12" o.c.	
	L/360	20'-1"	21'-5"	22'-9"	24'-0"	
40-20-5	L/480	16'-0"	20'-0"	22'-8"	24'-0"	
	L/360	16'-0"	20'-0"	22'-8"	24'-0"	

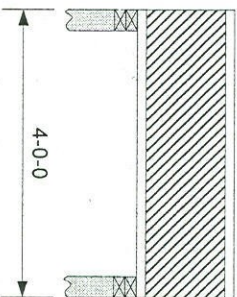

OSB: SEE TX96284011-001
 FOR SPACEJOIST TE
 ASSEMBLY NOTES

NOV 13 2003



DATE: 01/14/03
 Designed by Truswal Systems

ALL WEBS ARE 20 GAUGE SPACEJOIST METAL WEBS MANUFACTURED BY TRUSWAL SYSTEMS CORPORATION.

WARNING Read all notes on this sheet and give a copy of it to the Erecting Contractor.

This design is for an individual building component, not a truss system. It has been based on specifications provided by the component manufacturer and has been completed in accordance with the current versions of TPI and AFPA design standards. No responsibility is assumed for dimensional accuracy. Dimensions are to be verified by the component manufacturer and/or building designer prior to fabrication. The building designer shall ascertain that the loads utilized on this design meet or exceed the loading imposed by the local building code and the particular application. This design assumes that the top chord is laterally braced by the roof or floor sheathing and that the bottom chord is laterally braced by a rigid sheathing material directly attached, unless otherwise noted. Bracing shown is for lateral support of individual component members only. This component shall not be placed in any environment that will cause the moisture content of the wood to exceed 19% and/or cause connector plate corrosion. Fabricate, handle, install, and brace this truss in accordance with the following standards: SPACEJOIST TRUSS FABRICATION MANUAL, by Truswal Systems; Handling, Installing, and Bracing Metal Plate Connected Wood Trusses (HIB-91 and HIB-91 Summary Sheet) by TPI. The Truss Plate Institute is located at 583 D'Onofrio Dr., Ste. 200, Madison, WI 53719. The American Forest and Paper Association (AFPA) is located at 1111 19th St. N.W., Ste. 800, Washington, DC 20036.

CHK: Dsgnr: DL	Customer Name: SpaceJoist TE
TC Live 40 psf	DurFacs: L = 1.00 P = 1.00
TC Dead See Span Table	Rep Mbr Brnd: 1.15
BC Live 0 psf	Spacing: See Span Table
BC Dead 5 psf	Design Spec: TPI
TOTAL See Span Table	

Trimable End
SpaceJoist™
 1101 North Great Southwest Parkway
 Arlington, Texas 76011

TOP CHORD 3X2 SPF CAN, 1650F-1.5E
 BOTTOM CHORD 3X2 SPF CAN, 1650F-1.5E
 LUMBER SHEAR ALLOWABLES ARE PER NDS-1997

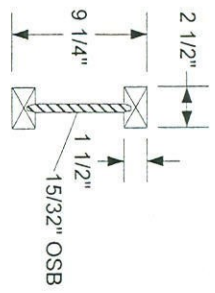

END DETAIL TYP.



THIS TRUSS IS TRIMMABLE
 UP TO 12" MAY BE FIELD-TRIMMED
 FROM EACH END OF THIS TRUSS

SEE TX96284011-001 FOR SPACEJOIST TE
 ASSEMBLY AND GENERAL NOTES

LOADING, PSF	9 1/4" SPACEJOIST TE MAXIMUM SPANS			
	DEFLECTION RATIO	SPACING		
40-10-5	L/480	24" o.c.	19.2" o.c.	16" o.c.
	L/360	14'-3"	14'-10"	16'-1"
40-20-5	L/480	15'-8"	16'-7"	17'-9"
	L/360	13'-7"	14'-9"	16'-0"
		13'-7"	16'-3"	17'-9"
				18'-0"

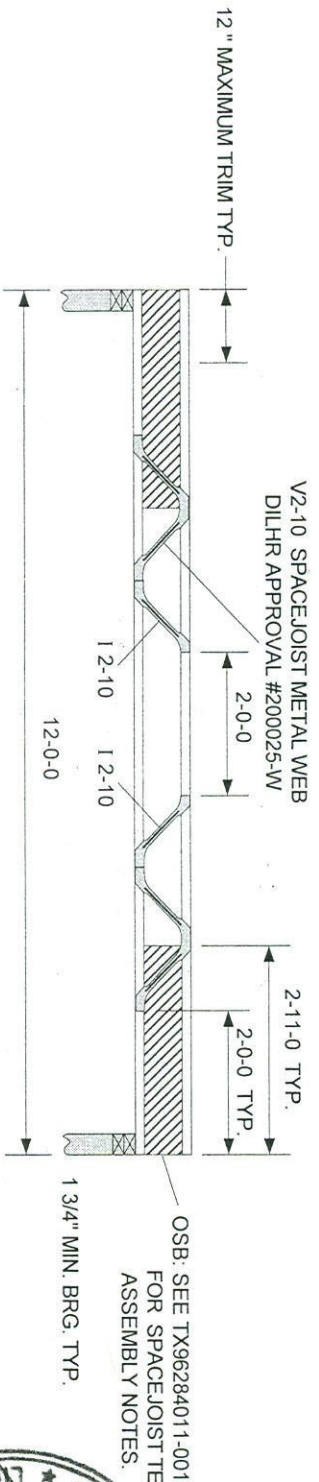

ALL WEBS ARE 20 GAUGE SPACEJOIST METAL WEBS MANUFACTURED BY TRUSSAL SYSTEMS CORPORATION.

WARNING Read all notes on this sheet and give a copy of it to the Erecting Contractor.

This design is for an individual building component, not a truss system. It has been based on specifications provided by the component manufacturer and has been completed in accordance with the current versions of TPI and AFPA design standards. No responsibility is assumed for dimensional accuracy. Dimensions are to be verified by the component manufacturer and/or building designer prior to fabrication. The building designer shall ascertain that the loads utilized on this design meet or exceed the loading imposed by the local building code and the particular application. This design assumes that the top chord is laterally braced by the roof or floor sheathing and that the bottom chord is laterally braced by a rigid sheathing material directly attached, unless otherwise noted. Bracing shown is for lateral support of individual component members only. This component shall not be placed in any environment that will cause the moisture content of the wood to exceed 19% and/or cause connector plate corrosion. Fabricate, handle, install, and brace this truss in accordance with the following standards: SPACEJOIST TRUSS FABRICATION MANUAL, by Trussal Systems; Handling, Installing, and Bracing Metal Plate Connected Wood Trusses (HIB-91 and HIB-91 Summary Sheet) by TPI. The Truss Plate Institute is located at 583 D'Onofrio Dr., Ste. 200, Madison, WI 53719. The American Forest and Paper Association (AFPA) is located at 1111 19th St. N.W., Ste. 800, Washington, DC 20036.

Trimable End
SpaceJoist™
 1101 North Great Southwest Parkway
 Arlington, Texas 76011

WARNING Read all notes on this sheet and give a copy of it to the Erecting Contractor.

CHK:	Customer Name:
Dsgnr: DL	SpaceJoist TE
TC Live 40 psf	DurFacs: L = 1.00 P = 1.00
TC Dead See Span Table	Rep Mbr Bnd: 1.15
BC Live 0 psf	Spacing: See Span Table
BC Dead 5 psf	Design Spec: TPI
TOTAL See Span Table	

Designed by Trussal Systems

NOV 19 2003
 DATE
 GARY T. OBUDZINSKI
 No. 080561
 LICENSED PROFESSIONAL ENGINEER
 STATE OF NEW YORK

TOP CHORD 3X2 SPF CAN. 2100F-1.8E
 BOTTOM CHORD 3X2 SPF CAN. 2100F-1.8E
 LUMBER SHEAR ALLOWABLES ARE PER NDS-1997

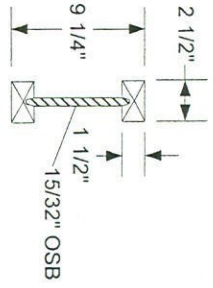

END DETAIL TYP.

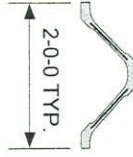

THIS TRUSS IS TRIMMABLE
 UP TO 12" MAY BE FIELD-TRIMMED
 FROM EACH END OF THIS TRUSS

SEE TX96284011-001 FOR SPACEJOIST TE
 ASSEMBLY AND GENERAL NOTES

LOADING, PSF	9 1/4" SPACEJOIST TE MAXIMUM SPANS			
	DEFLECTION RATIO	SPACING		
40-10-5	L/480	24" o.c.	19.2" o.c.	16" o.c.
	L/360	14'-3"	14'-10"	16'-1"
40-20-5	L/480	15'-8"	16'-7"	17'-9"
	L/360	13'-7"	14'-9"	16'-0"
		13'-7"	16'-3"	17'-9"
				18'-0"

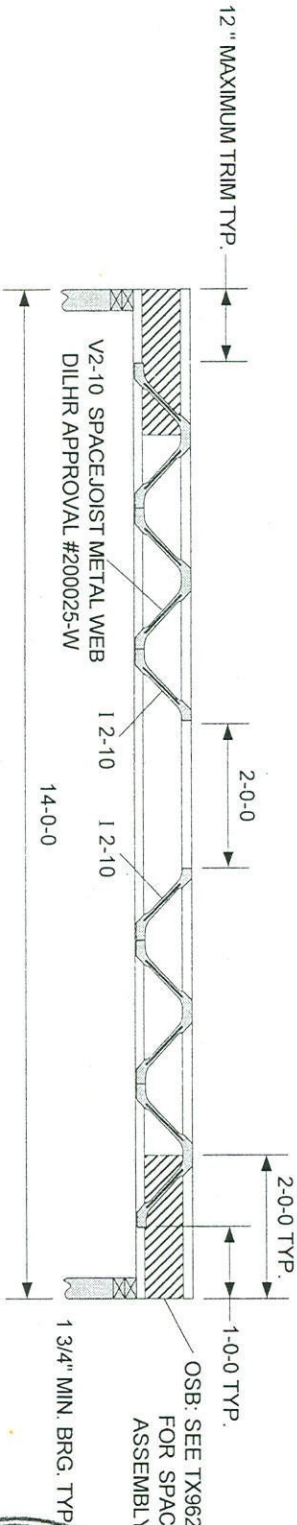

OSB: SEE TX96284011-001
 FOR SPACEJOIST TE
 ASSEMBLY NOTES

ALL WEBS ARE 20 GAUGE SPACEJOIST METAL WEBS MANUFACTURED BY TRUSSAL SYSTEMS CORPORATION.

WARNING Read all notes on this sheet and give a copy of it to the Erecting Contractor.

This design is for an individual building component, not a truss system. It has been based on specifications provided by the component manufacturer and has been completed in accordance with the current versions of TPI and AFPA design standards. No responsibility is assumed for dimensional accuracy.

Dimensions are to be verified by the component manufacturer and/or building designer prior to fabrication. The building designer shall ascertain that the loads utilized on this design meet or exceed the loading imposed by the local building code and the particular application. This design assumes that the top chord is laterally braced by the roof or floor sheathing and that the bottom chord is laterally braced by a rigid sheathing material directly attached, unless otherwise noted. Bracing shown is for lateral support of individual component members only. This component shall not be placed in any environment that will cause the moisture content of the wood to exceed 19% and/or cause connector plate corrosion. Fabricate, handle, install, and brace this truss in accordance with the following standards: SPACEJOIST TRUSS FABRICATION MANUAL, by Trussal Systems; Handling, Installing, and Bracing Metal Plate Connected Wood Trusses (HIB-91 and HIB-91 Summary Sheet) by TPI. The Truss Plate Institute is located at 683 Orono Dr., Ste. 200, Madison, WI 53719. The American Forest and Paper Association (AFPA) is located at 1111 19th St. N.W., Ste. 800, Washington, DC 20036.



1101 North Great Southwest Parkway
 Arlington, Texas 76011

CHK: Dsgnr: DL	TC Live 40 psf	DurFacs: L=1.00 P=1.00
	TC Dead See Span Table	Rep Mbr Bnd: 1.15
	BC Live 0 psf	Spacing: See SpanTable
	BC Dead 5 psf	Design Spec: TPI
	TOTAL See Span Table	

Designed by Trussal Systems



TOP CHORD 3X2 SPF CAN. 2100F-1.8E
 BOTTOM CHORD 3X2 SPF CAN. 2100F-1.8E
 LUMBER SHEAR ALLOWABLES ARE PER NDS-1997

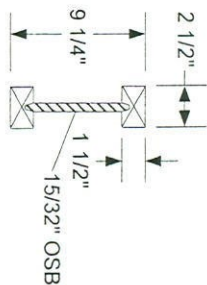

END DETAIL TYP.

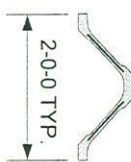

THIS TRUSS IS TRIMMABLE
 UP TO 12" MAY BE FIELD-TRIMMED
 FROM EACH END OF THIS TRUSS

SEE TX96284011-001 FOR SPACEJOIST TE
 ASSEMBLY AND GENERAL NOTES

LOADING, PSF	9 1/4" SPACEJOIST TE MAXIMUM SPANS			
	DEFLECTION RATIO	SPACING		
40-10-5	L/480	24" o.c.	19.2" o.c.	16" o.c.
	L/360	14'-3"	14'-10"	16'-1"
40-20-5	L/480	15'-8"	16'-7"	17'-9"
	L/360	13'-7"	14'-9"	16'-0"
		13'-7"	16'-3"	17'-9"
			16'-3"	18'-0"

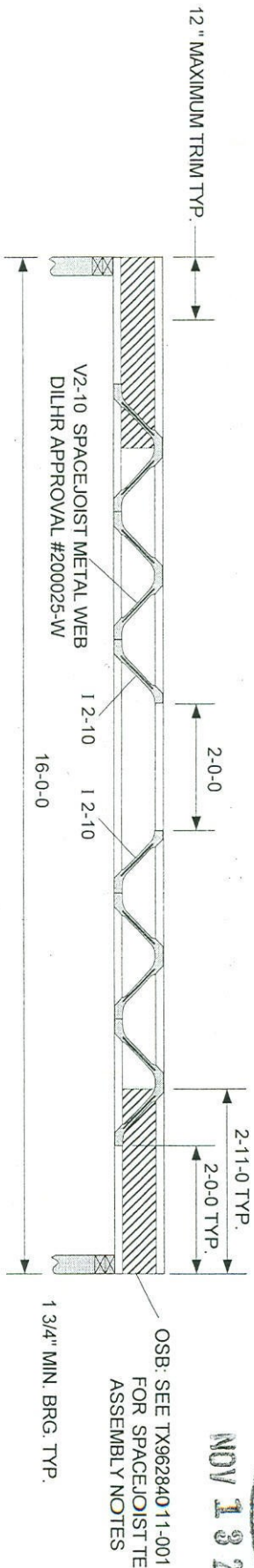

NOV 13 2003

OSB: SEE TX96284011-001
 FOR SPACEJOIST TE
 ASSEMBLY NOTES

1 3/4" MIN. BRG. TYP.

ALL WEBS ARE 20 GAUGE SPACEJOIST METAL WEBS MANUFACTURED BY TRUSWAL SYSTEMS CORPORATION.

WARNING Read all notes on this sheet and give a copy of it to the Erecting Contractor.

This design is for an individual building component, not a truss system. It has been based on specifications provided by the component manufacturer and has been completed in accordance with the current versions of TPI and AFPA design standards. No responsibility is assumed for dimensional accuracy. Dimensions are to be verified by the component manufacturer and/or building designer prior to fabrication. The building designer shall ascertain that the loads utilized on this design meet or exceed the loading imposed by the local building code and the particular application. This design assumes that the top chord is laterally braced by the roof or floor sheathing and that the bottom chord is laterally braced by a rigid sheathing material directly attached, unless otherwise noted. Bracing shown is for lateral support of individual component members only. This component shall not be placed in any environment that will cause the moisture content of the wood to exceed 19% and/or cause connector plate corrosion. Fabricate, handle, install, and brace this truss in accordance with the following standards: SPACEJOIST TRUSS FABRICATION MANUAL, by Truswal Systems; Handling, Installing, and Bracing Metal Plate Connected Wood Trusses (HIB-91 and HIB-91 Summary Sheet) by TPI. The Truss Plate Institute is located at 583 D'Onofrio Dr., Ste. 200, Madison, WI 53719. The American Forest and Paper Association (AFPA) is located at 1111 19th St. N.W., Ste. 800, Washington, DC 20036.

CHK: Dsgnr: DL

Customer Name: SpaceJoist TE

DATE: 01/14/03

Designed by Truswal Syst



Trimable End

SpaceJoist™

1101 North Great Southwest Parkway
 Arlington, Texas 76011

TC Live	40 psf	DurFacs: L= 1.00 P= 1.00
TC Dead	See Span Table	Rep Mbr Bnd: 1.15
BC Live	0 psf	Spacing: See Span Table
BC Dead	5 psf	Design Spec: TPI
TOTAL See Span Table		

TOP CHORD 3X2 SPF CAN. 2100F-1.8E
 BOTTOM CHORD 3X2 SPF CAN. 2100F-1.8E
 LUMBER SHEAR ALLOWABLES ARE PER NDS-1997

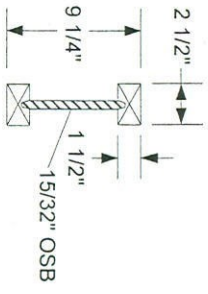

LOADING, PSF	9 1/4" SPACEJOIST TE MAXIMUM SPANS			
	DEFLECTION RATIO	SPACING		
40-10-5	L/480	24" O.C.	19.2" O.C.	16" O.C.
	L/360	14'-3"	14'-10"	16'-1"
	L/480	15'-8"	16'-7"	17'-9"
40-20-5	L/360	13'-7"	14'-9"	16'-0"
	L/480	13'-7"	14'-9"	17'-9"
	L/360	13'-7"	16'-3"	17'-9"
				18'-0"

THIS TRUSS IS TRIMMABLE
 UP TO 12" MAY BE FIELD-TRIMMED
 FROM EACH END OF THIS TRUSS

SEE TX96284011-001 FOR SPACEJOIST TE
 ASSEMBLY AND GENERAL NOTES

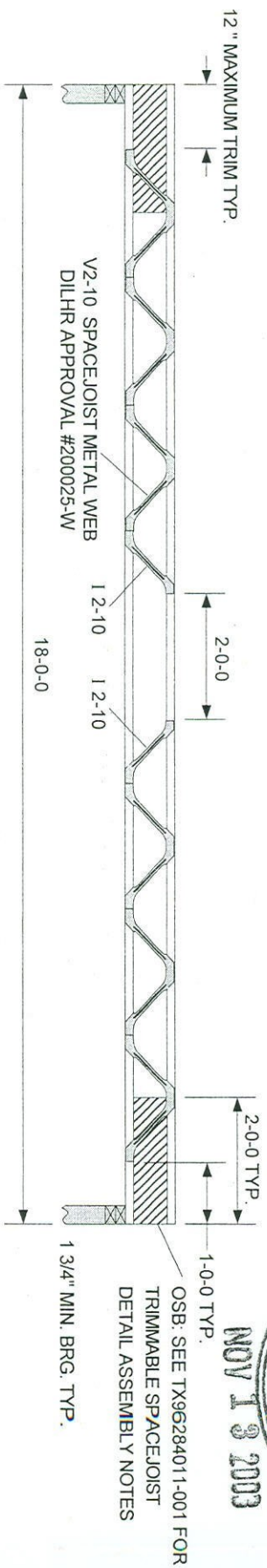

NOV 13 2003



OSB: SEE TX96284011-001 FOR
 TRIMMABLE SPACEJOIST
 DETAIL ASSEMBLY NOTES

ALL WEBS ARE 20 GAUGE SPACEJOIST METAL WEBS MANUFACTURED BY TRUSSAL SYSTEMS CORPORATION.

WARNING Read all notes on this sheet and give a copy of it to the Erecting Contractor.

This design is for an individual building component, not a truss system. It has been based on specifications provided by the component manufacturer and has been completed in accordance with the current versions of TPI and AFPA design standards. No responsibility is assumed for dimensional accuracy. Dimensions are to be verified by the component manufacturer and/or building designer prior to fabrication. The building designer shall ascertain that the loads utilized on this design meet or exceed the loading imposed by the local building code and the particular application. This design assumes that the top chord is laterally braced by the roof or floor sheathing and that the bottom chord is laterally braced by a rigid sheathing material directly attached, unless otherwise noted. Bracing shown is for lateral support of individual component members only. This component shall not be placed in any environment that will cause the moisture content of the wood to exceed 19% and/or cause connector plate corrosion. Fabricate, handle, install, and brace this truss in accordance with the following standards: SPACEJOIST TRUSS FABRICATION MANUAL, by Trussal Systems; Handling, Installing, and Bracing Metal Plate Connected Wood Trusses (HIB-91 and HIB-91 Summary Sheet) by TPI. The Truss Plate Institute is located at 593 D'Onofrio Dr., Ste. 200, Madison, WI 53719. The American Forest and Paper Association (AFPA) is located at 1111 19th St. N.W., Ste. 900, Washington, DC 20036.

CHK:	Customer Name:
Desgnr: DL	SpaceJoist TE
TC Live	40 psf
TC Dead	See Span Table
BC Live	0 psf
BC Dead	5 psf
TOTAL	See Span Table
DurFacs: L= 1.00 P= 1.00	Design Spec: TPI
Rep Mbr Bnd: 1.15	



1101 North Great Southwest Parkway
 Arlington, Texas 76011

DATE: 01/14/03
 Designed by Trussal Systems

TOP CHORD 3X2 SPF CAN. 1650F-1.5E
 BOTTOM CHORD 3X2 SPF CAN. 1650F-1.5E
 LUMBER SHEAR ALLOWABLES ARE PER NDS-1997

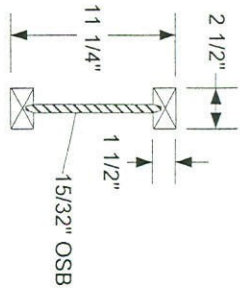

LOADING, PSF	11 1/4" SPACEJOIST TE MAXIMUM SPANS			
	DEFLECTION RATIO	SPACING		
40-10-5	L/480	24" o.c.	19.2" o.c.	16" o.c.
	L/360	16'-10"	18'-3"	19'-2"
40-20-5	L/480	17'-9"	19'-11"	21'-2"
	L/360	14'-0"	18'-0"	21'-2"
		14'-0"	18'-0"	20'-2"
				22'-0"

THIS TRUSS IS TRIMMABLE
 UP TO 12" MAY BE FIELD-TRIMMED
 FROM EACH END OF THIS TRUSS

SEE TX96284011-001 FOR SPACEJOIST TE
 ASSEMBLY AND GENERAL NOTES

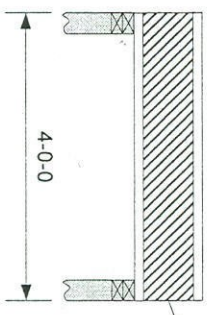

OSB: SEE TX96284011-001
 FOR SPACEJOIST TE
 ASSEMBLY NOTES



NOV 13 2003
 DATE: 01/14/03

ALL WEBS ARE 20 GAUGE SPACEJOIST METAL WEBS MANUFACTURED BY TRUSSAL SYSTEMS CORPORATION. DESIGNED BY TRUSSAL SYSTEMS

WARNING Read all notes on this sheet and give a copy of it to the Erecting Contractor.

This design is for an individual building component, not a truss system. It has been based on specifications provided by the component manufacturer and has been completed in accordance with the current versions of TPI and AFPA design standards. No responsibility is assumed for dimensional accuracy. Dimensions are to be verified by the component manufacturer and/or building designer prior to fabrication. The building designer shall ascertain that the loads utilized on this design meet or exceed the loading imposed by the local building code and the particular application. This design assumes that the top chord is laterally braced by the roof or floor sheathing and that the bottom chord is laterally braced by a rigid sheathing material directly attached, unless otherwise noted. Bracing shown is for lateral support of individual component members only. This component shall not be placed in any environment that will cause the moisture content of the wood to exceed 19% and/or cause connector plate corrosion. Fabricate, handle, install, and brace this truss in accordance with the following standards: SPACEJOIST TRUSS FABRICATION MANUAL, by Trussal Systems; Handling, Installing, and Bracing Metal Plate Connected Wood Trusses (HIB-91 and HIB-91 Summary Sheet) by TPI. The Truss Plate Institute is located at 583 D'Onofrio Dr., Ste. 200, Madison, WI 53719. The American Forest and Paper Association (AFPA) is located at 1111 19th St. N.W., Ste. 800, Washington, DC 20036.

CHK: _____	Customer Name: _____
Dsgnr: DL	SpaceJoist TE
TC Live 40 psf	DurFacs: L = 1.00 P = 1.00
TC Dead See Span Table	Rep Mbr Brd: 1.15
BC Live 0 psf	Spacing: See Span Table
BC Dead 5 psf	Design Spec: TPI
TOTAL See Span Table	



1101 North Great Southwest Parkway
 Arlington, Texas 76011

TOP CHORD 3X2 SPF CAN. 1650F-1.5E
 BOTTOM CHORD 3X2 SPF CAN. 1650F-1.5E
 LUMBER SHEAR ALLOWABLES ARE PER NDS-1997

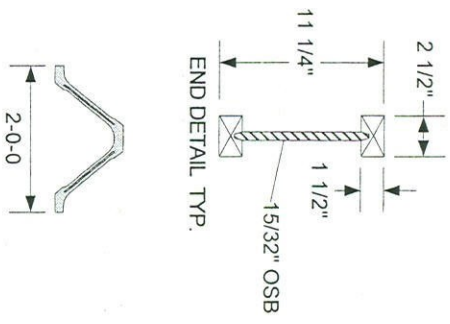

LOADING, PSF	11 1/4" SPACEJOIST TE MAXIMUM SPANS		
	DEFLECTION RATIO	SPACING	
40-10-5	L/480	24" o.c.	12" o.c.
	L/360	16'-10"	19'-2"
40-20-5	L/480	17'-9"	16" o.c.
	L/360	14'-0"	19'-2"
		18'-0"	20'-2"
		14'-0"	22'-0"

THIS TRUSS IS TRIMMABLE
 UP TO 18" MAY BE FIELD-TRIMMED FROM EACH END OF THIS TRUSS

SEE TX96284011-001 FOR SPACEJOIST TE ASSEMBLY AND GENERAL NOTES

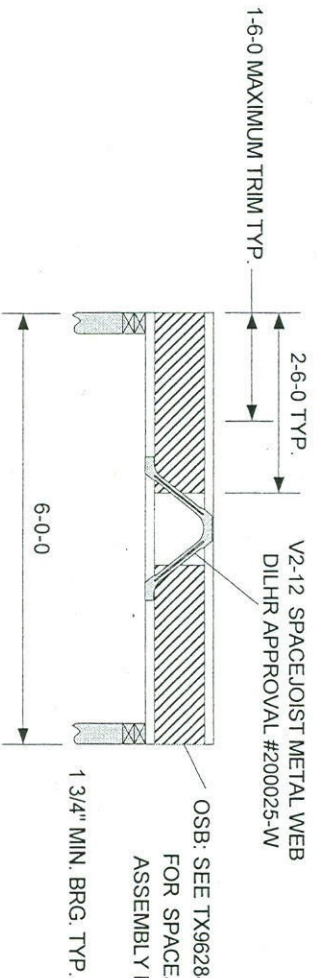

ALL WEBS ARE 20 GAUGE SPACEJOIST METAL WEBS MANUFACTURED BY TRUSWAL SYSTEMS CORPORATION.

WARNING Read all notes on this sheet and give a copy of it to the Erecting Contractor.

This design is for an individual building component, not a truss system. It has been based on specifications provided by the component manufacturer and has been completed in accordance with the current versions of TPI and AFPA design standards. No responsibility is assumed for dimensional accuracy. Dimensions are to be verified by the component manufacturer and/or building designer prior to fabrication. The building designer shall ascertain that the loads utilized on this design meet or exceed the loading imposed by the local building code and the particular application. This design assumes that the top chord is laterally braced by the roof or floor sheathing and that the bottom chord is laterally braced by a rigid sheathing material directly attached, unless otherwise noted. Bracing shown is for lateral support of individual component members only. This component shall not be placed in any environment that will cause the moisture content of the wood to exceed 19% and/or cause connector plate corrosion. Fabricate, handle, install, and brace this truss in accordance with the following standards: SPACEJOIST TRUSS FABRICATION MANUAL, by Trussal Systems, Handling, Installing, and Bracing Metal Plate Connected Wood Trusses (HB-91 and HB-91 Summary Sheet) by TPI, The Truss Plate Institute is located at 583 D'Onofrio Dr., Ste. 200, Madison, WI 53719. The American Forest and Paper Association (AFPA) is located at 1111 19th St. N.W., Ste. 800, Washington, DC 20036.

Chk:		Customer Name:	SpaceJoist TE
Dsgnr: DL			
TC Live	40 psf	DurFacs: L = 1.00 P = 1.00	
TC Dead	See Span Table	Rep Mbr Bnd: 1.15	
BC Live	0 psf	Spacing: See Span Table	
BC Dead	5 psf	Design Spec: TPI	
TOTAL See Span Table			

NOV 13 2003

DATE: 01/14/03

DESIGNED BY TRUSWAL SYSTEMS



MEA 262-03-E

Trimable End
SpaceJoistTM
 1101 North Great Southwest Parkway
 Arlington, Texas 76011

TOP CHORD 3X2 SPF CAN. 1650F-1.5E
 BOTTOM CHORD 3X2 SPF CAN. 1650F-1.5E
 LUMBER SHEAR ALLOWABLES ARE PER NDS-1997

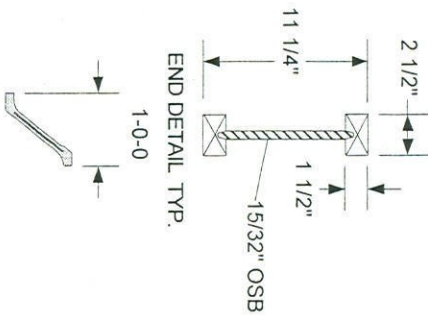

LOADING, PSF	11 1/4" SPACEJOIST TE MAXIMUM SPANS			
	DEFLECTION RATIO	SPACING		
40-10-5	L/480	24" o.c.	19.2" o.c.	16" o.c.
	L/360	16'-10"	18'-3"	19'-2"
40-20-5	L/480	17'-9"	19'-11"	21'-2"
	L/360	14'-0"	18'-0"	19'-2"
		14'-0"	18'-0"	20'-2"
				22'-0"

THIS TRUSS IS TRIMMABLE
 UP TO 12" MAY BE FIELD-TRIMMED
 FROM EACH END OF THIS TRUSS

SEE TX96284011-001 FOR SPACEJOIST TE
 ASSEMBLY AND GENERAL NOTES

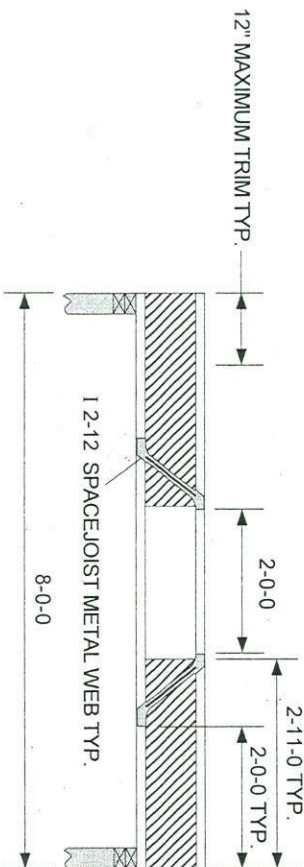

ALL WEBS ARE 20 GAUGE SPACEJOIST METAL WEBS MANUFACTURED BY TRUSSAL SYSTEMS CORPORATION.

WARNING Read all notes on this sheet and give a copy of it to the Erecting Contractor.

This design is for an individual building component, not a truss system. It has been based on specifications provided by the component manufacturer and has been completed in accordance with the current versions of TPI and AFPA design standards. No responsibility is assumed for dimensional accuracy. Dimensions are to be verified by the component manufacturer and/or building designer prior to fabrication. The building designer shall ascertain that the loads utilized on this design meet or exceed the loading imposed by the local building code and the particular application. This design assumes that the top chord is laterally braced by the roof or floor sheathing and that the bottom chord is laterally braced by a rigid sheathing material directly attached, unless otherwise noted. Bracing shown is for lateral support of individual component members only. This component shall not be placed in any environment that will cause the moisture content of the wood to exceed 19% and/or cause connector plate corrosion. Fabricate, handle, install, and brace this truss in accordance with the following standards: SPACEJOIST TRUSS FABRICATION MANUAL, by Trussal Systems; Handling, Installing, and Bracing Metal Plate Connected Wood Trusses (HIB-91 and HIB-91 Summary Sheet) by TPI. The Truss Plate Institute is located at 583 D'Onofrio Dr., Ste. 200, Madison, WI 53719. The American Forest and Paper Association (AFPA) is located at 1111 19th St. N.W., Ste. 800, Washington, DC 20003.



1101 North Great Southwest Parkway
 Arlington, Texas 76011

NOV 19 2003

DATE: 01/14/03

DESIGNED BY TRUSSAL SYSTEMS



CHK: Dsgnr: DL	Customer Name: SpaceJoist TE
----------------	------------------------------

TC Live	40 psf	DurFacs: L= 1.00 P= 1.00
TC Dead	See Span Table	Rep Mbr End: 1.15
BC Live	0 psf	Spacing: See Span Table
BC Dead	5 psf	Design Spec: TPI
TOTAL See Span Table		

TOP CHORD 3X2 SPF CAN. 1650F-1.5E
 BOTTOM CHORD 3X2 SPF CAN. 1650F-1.5E
 LUMBER SHEAR ALLOWABLES ARE PER NDS-1997

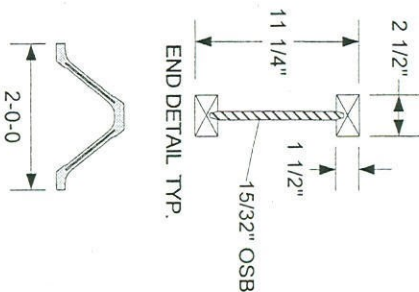

THIS TRUSS IS TRIMMABLE
 UP TO 12" MAY BE FIELD-TRIMMED
 FROM EACH END OF THIS TRUSS

SEE TX96284011-001 FOR SPACEJOIST TE
 ASSEMBLY AND GENERAL NOTES

V2-12 SPACEJOIST METAL WEB
 DILHR APPROVAL #200025-1W

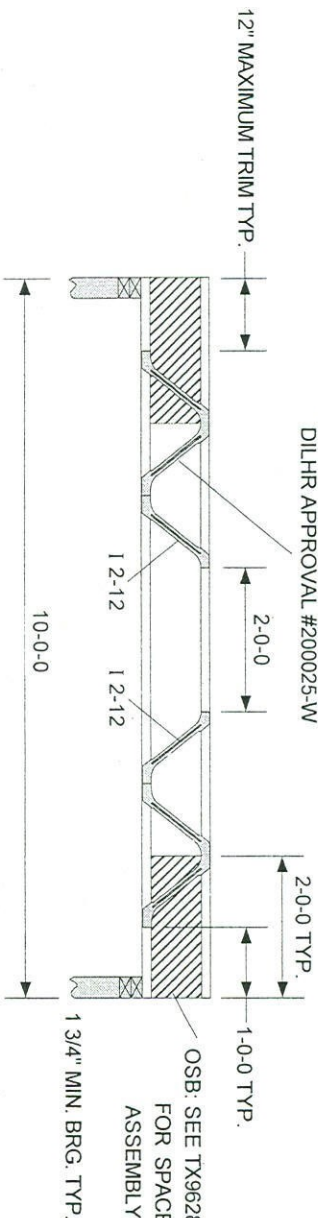

OSB: SEE TX96284011-001
 FOR SPACEJOIST TE
 ASSEMBLY NOTES

LOADING, PSF	11 1/4" SPACEJOIST TE MAXIMUM SPANS		
	DEFLECTION RATIO	SPACING	
40-10-5	L/480	24" o.c.	12" o.c.
	L/360	16'-10"	19'-2"
40-20-5	L/480	17'-9"	21'-2"
	L/360	14'-0"	19'-11"
		18'-0"	22'-0"
		14'-0"	20'-2"
		18'-0"	22'-0"

ALL WEBS ARE 20 GAUGE SPACEJOIST METAL WEBS MANUFACTURED BY TRUSSAL SYSTEMS CORPORATION.

WARNING Read all notes on this sheet and give a copy of it to the Erecting Contractor.

Trimable End

SpaceJoist™

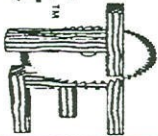

1101 North Great Southwest Parkway
 Arlington, Texas 76011

This design is for an individual building component, not a truss system. It has been based on specifications provided by the component manufacturer and has been completed in accordance with the current versions of TPI and AFPA design standards. No responsibility is assumed for dimensional accuracy. Dimensions are to be verified by the component manufacturer and/or building designer prior to fabrication. The building designer shall ascertain that the loads utilized on this design meet or exceed the loading imposed by the local building code and the particular application. This design assumes that the top chord is laterally braced by the roof or floor sheathing and that the bottom chord is laterally braced by a rigid sheathing material directly attached, unless otherwise noted. Bracing shown is for lateral support of individual component members only. This component shall not be placed in any environment that will cause the moisture content of the wood to exceed 19% and/or cause connector plate corrosion. Fabricate, handle, install, and brace this truss in accordance with the following standards: SPACEJOIST TRUSS FABRICATION MANUAL, by Trussal Systems; Handling, Installing, and Bracing Metal Plate Connected Wood Trusses (HIB-91 and HIB-91 Summary Sheet) by TPI; The Truss Plate Institute is located at 583 D'Oroffo Dr., Ste. 200, Madison, WI 53719. The American Forest and Paper Association (AFPA) is located at 1111 19th St. N.W., Ste. 800, Washington, DC 20036.

CHK: Dsgnr: DL

Customer Name: SpaceJoist TE

DESIGNED BY TRUSSAL SYSTEMS

DATE: 01/14/03

NOV 13 2003



MEA 262-03-E

TC Live	40 psf	DurFacs: L=1.00 P=1.00
TC Dead	See Span Table	Rep Mbr Bnd: 1.15
BC Live	0 psf	Spacing: See Span Table
BC Dead	5 psf	Design Spec: TPI
TOTAL	See Span Table	

Job Name: SpaceJoist TE

Truss ID: TE12-12N

Drwg: TX03014021-013

QGNR-1F

TOP CHORD 3X2 SPF CAN. 1650F-1.5E
 BOTTOM CHORD 3X2 SPF CAN. 1650F-1.5E
 LUMBER SHEAR ALLOWABLES ARE PER NDS-1997

LOADING, PSF	11 1/4" SPACEJOIST TE MAXIMUM SPANS				
	SPACING				
DEFLECTION RATIO	24" O.C.	19.2" O.C.	16" O.C.	12" O.C.	
40-10-5	L/480	16'-10"	18'-3"	19'-2"	21'-2"
40-20-5	L/360	17'-9"	19'-11"	21'-2"	22'-0"
	L/480	14'-0"	18'-0"	19'-2"	21'-2"
	L/360	14'-0"	18'-0"	20'-2"	22'-0"

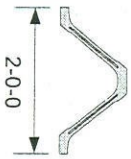
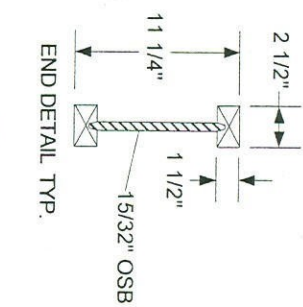

THIS TRUSS IS TRIMMABLE
 UP TO 12" MAY BE FIELD-TRIMMED
 FROM EACH END OF THIS TRUSS

SEE TX96284011-001 FOR SPACEJOIST TE
 ASSEMBLY AND GENERAL NOTES

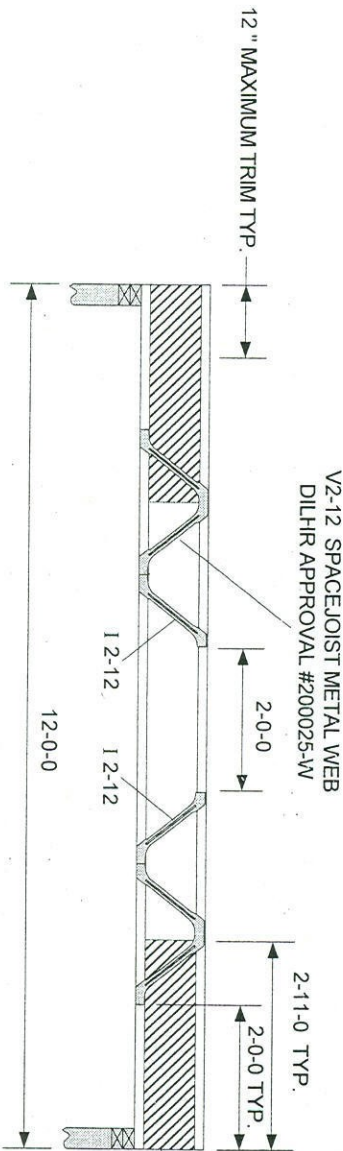

OSB: SEE TX96284011-001
 FOR SPACEJOIST TE
 ASSEMBLY NOTES

ALL WEBS ARE 20 GAUGE SPACEJOIST METAL WEBS MANUFACTURED BY TRUSVAL SYSTEMS CORPORATION.

WARNING Read all notes on this sheet and give a copy of it to the Erecting Contractor.

This design is for an individual building component, not a truss system. It has been based on specifications provided by the component manufacturer and has been completed in accordance with the current versions of TPI and AFPA design standards. No responsibility is assumed for dimensional accuracy. Dimensions are to be verified by the component manufacturer and/or building designer prior to fabrication. The building designer shall ascertain that the loads utilized on this design meet or exceed the loading imposed by the local building code and the particular application. This design assumes that the top chord is laterally braced by the roof or floor sheathing and that the bottom chord is laterally braced by a rigid sheathing material directly attached, unless otherwise noted. Bracing shown is for lateral support of individual component members only. This component shall not be placed in any environment that will cause the moisture content of the wood to exceed 19% and/or cause connector plate corrosion. Fabricate, handle, install, and brace this truss in accordance with the following standards: SPACEJOIST TRUSS FABRICATION MANUAL, by Trusval Systems, Handling, Installing, and Bracing Metal Plate Connected Wood Trusses (HIB-91 and HIB-91 Summary Sheet) by TPI, The Truss Plate Institute is located at 583 D'Orofino Dr., Ste. 200, Madison, WI 53719. The American Forest and Paper Association (AFPA) is located at 1111 19th St. N.W., Ste. 800, Washington, DC 20036.

NOV 13 2003

DESIGNED BY TRUSVAL SYSTEMS



MEA 262-03-E

21 of 51 pages

Trimable End
SpaceJoist
 1101 North Great Southwest Parkway
 Arlington, Texas 76011

CHK: Dsgnr: DL	Customer Name: SpaceJoist TE
TC Live 40 psf	DurFacs: L= 1.00 P= 1.00
TC Dead See Span Table	Rep Mbr End: 1.15
BC Live 0 psf	Spacing: See Span Table
BC Dead 5 psf	Design Spec: TPI
TOTAL See Span Table	

TOP CHORD 3X2 SPF CAN. 2100F-1.8E
 BOTTOM CHORD 3X2 SPF CAN. 2100F-1.8E
 LUMBER SHEAR ALLOWABLES ARE PER NDS-1997

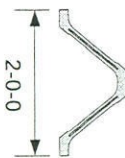
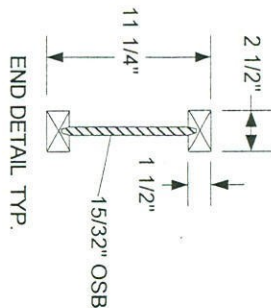

THIS TRUSS IS TRIMMABLE
 UP TO 12" MAY BE FIELD-TRIMMED
 FROM EACH END OF THIS TRUSS

SEE TX96284011-001 FOR SPACEJOIST TE
 ASSEMBLY AND GENERAL NOTES

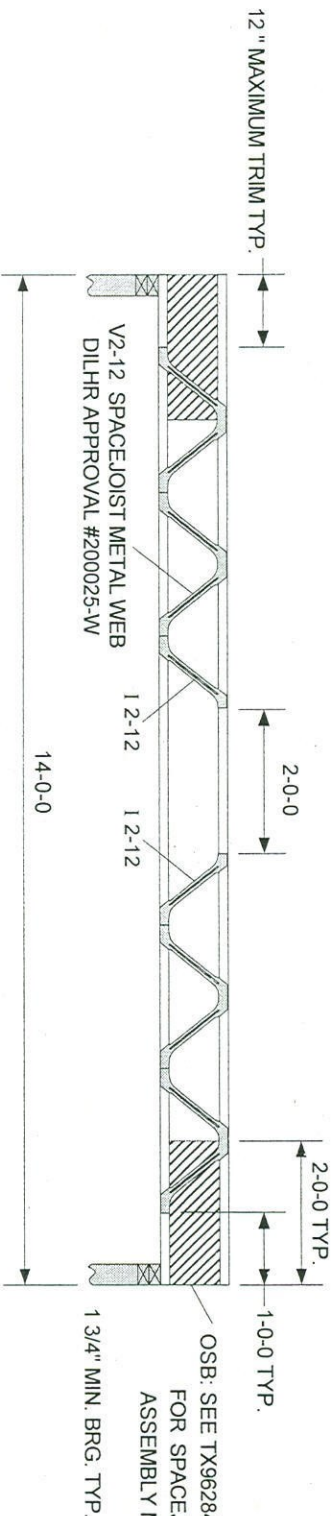

LOADING, PSF	11 1/4" SPACEJOIST TE MAXIMUM SPANS			
	DEFLECTION RATIO	SPACING		
40-10-5	L/480	24" O.C.	19'-2" O.C.	16" O.C.
	L/360	16'-10"	18'-3"	19'-2"
40-20-5	L/480	17'-9"	19'-11"	21'-2"
	L/360	14'-0"	18'-0"	19'-2"
		14'-0"	18'-0"	20'-2"
				22'-0"

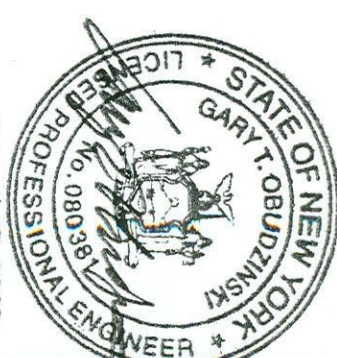

NOV 13 2003

ALL WEBS ARE 20 GAUGE SPACEJOIST METAL WEBS MANUFACTURED BY TRUSSAL SYSTEMS CORPORATION.

WARNING Read all notes on this sheet and give a copy of it to the Erecting Contractor.

This design is for an individual building component, not a truss system. It has been based on specifications provided by the component manufacturer and has been completed in accordance with the current versions of TPI and AFPA design standards. No responsibility is assumed for dimensional accuracy. Dimensions are to be verified by the component manufacturer and/or building designer prior to fabrication. The building designer shall ascertain that the loads utilized on this design meet or exceed the loading imposed by the local building code and the particular application. This design assumes that the top chord is laterally braced by the roof or floor sheathing and that the bottom chord is laterally braced by a rigid sheathing material directly attached, unless otherwise noted. Bracing shown is for lateral support of individual component members only. This component shall not be placed in any environment that will cause the moisture content of the wood to exceed 19% and/or cause connector plate corrosion. Fabricate, handle, install, and brace this truss in accordance with the following standards: SPACEJOIST TRUSS FABRICATION MANUAL, by Trussal Systems; Handling, Installing, and Bracing Metal Plate Connected Wood Trusses (HIB-91 and HB-91 Summary Sheet) by TPI. The Truss Plate Institute is located at 583 D'Onofrio Dr., Ste. 200, Madison, WI 53719. The American Forest and Paper Association (AFPA) is located at 1111 19th St. N.W., Ste. 800, Washington, DC 20006.

CHK: Dsgnr: DL	Customer Name: SpaceJoist TE
TC Live 40 psf	DurFacs: L= 1.00 P= 1.00
TC Dead See Span Table	Rep Mbr End: 1.15
BC Live 0 psf	Spacing: See Span Table
BC Dead 5 psf	Design Spec: TPI
TOTAL See Span Table	



Trimable End

SpaceJoist™

1101 North Great Southwest Parkway
 Arlington, Texas 76011

TOP CHORD 3X2 SPF CAN. 2100F-1.8E
 BOTTOM CHORD 3X2 SPF CAN. 2100F-1.8E
 LUMBER SHEAR ALLOWABLES ARE PER NDS-1997

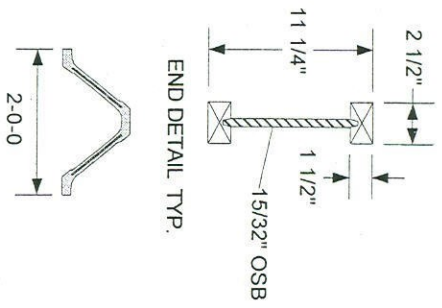

THIS TRUSS IS TRIMMABLE
 UP TO 12" MAY BE FIELD-TRIMMED
 FROM EACH END OF THIS TRUSS

SEE TX96284011-001 FOR SPACEJOIST TE
 ASSEMBLY AND GENERAL NOTES

LOADING, PSF	11 1/4" SPACEJOIST TE MAXIMUM SPANS			
	SPACING			
DEFLECTION RATIO	24" o.c.	19.2" o.c.	16" o.c.	12" o.c.
	40-10-5	L/480	16'-10"	18'-3"
L/360		17'-9"	19'-11"	21'-0"
40-20-5	L/480	14'-0"	18'-0"	21'-2"
	L/360	14'-0"	18'-0"	22'-0"

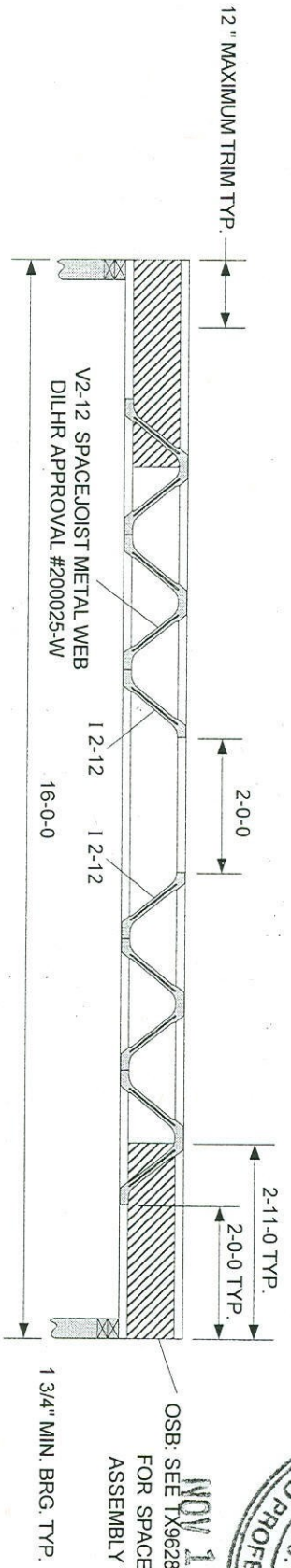

NOV 19 2003
 OSB: SEE TX96284011-001
 FOR SPACEJOIST TE
 ASSEMBLY NOTES



ALL WEBS ARE 20 GAUGE SPACEJOIST METAL WEBS MANUFACTURED BY TRUSSAL SYSTEMS CORPORATION.

WARNING Read all notes on this sheet and give a copy of it to the Erecting Contractor.

This design is for an individual building component, not a truss system. It has been based on specifications provided by the component manufacturer and has been completed in accordance with the current versions of TPI and AFPA design standards. No responsibility is assumed for dimensional accuracy. Dimensions are to be verified by the component manufacturer and/or building designer prior to fabrication. The building designer shall ascertain that the loads utilized on this design meet or exceed the loading imposed by the local building code and the particular application. This design assumes that the top chord is laterally braced by the roof or floor sheathing and that the bottom chord is laterally braced by a rigid sheathing material directly attached, unless otherwise noted. Bracing shown is for lateral support of individual component members only. This component shall not be placed in any environment that will cause the moisture content of the wood to exceed 19% and/or cause connector plate corrosion. Fabricate, handle, install, and brace this truss in accordance with the following standards: SPACEJOIST TRUSS FABRICATION MANUAL, by Trussal Systems; Handling, Installing, and Bracing Metal Plate Connected Wood Trusses (HB-91 and HB-91 Summary Sheet) by TPI. The Truss Plate Institute is located at 583 D Onofrio Dr., Ste. 200, Madison, WI 53719. The American Forest and Paper Association (AFPA) is located at 1111 19th St. N.W., Ste. 800, Washington, DC 20036.

CHK: Dsgnr: DL	Customer Name: SpaceJoist TE
TC Live 40 psf	DurFacs: L= 1.00 P= 1.00
TC Dead See Span Table	Rep Mbr Bnd: 1.15
BC Live 0 psf	Spacing: See Span Table
BC Dead 5 psf	Design Spec: TPI
TOTAL See Span Table	

Trimable End
SpaceJoist™
 1101 North Great Southwest Parkway
 Arlington, Texas 76011

Job Name: SpaceJoist TE

Truss ID: TE12-18N

Drwg: TX03014021-016

QGNR-1F

TOP CHORD 3X2 SPF CAN. 2100F-1.8E
 BOTTOM CHORD 3X2 SPF CAN. 2100F-1.8E
 LUMBER SHEAR ALLOWABLES ARE PER NDS-1997

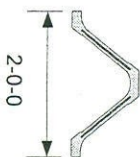
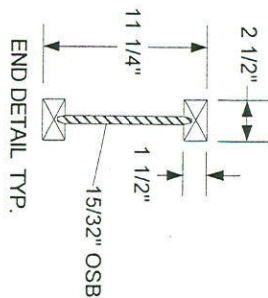

THIS TRUSS IS TRIMMABLE
 UP TO 12" MAY BE FIELD-TRIMMED
 FROM EACH END OF THIS TRUSS

SEE TX96284011-001 FOR SPACEJOIST TE
 ASSEMBLY AND GENERAL NOTES

LOADING, PSF	11 1/4" SPACEJOIST TE MAXIMUM SPANS			
	DEFLECTION RATIO	SPACING		
40-10-5	L/480	24" o.c.	19.2" o.c.	16" o.c.
	L/360	16'-10"	18'-3"	19'-2"
40-20-5	L/480	17'-9"	19'-11"	21'-2"
	L/360	14'-0"	18'-0"	21'-2"

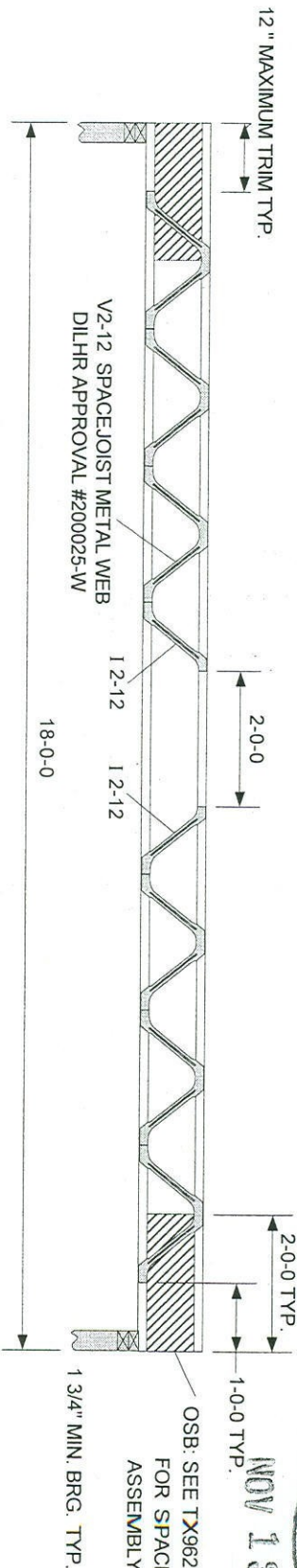

ALL WEBS ARE 20 GAUGE SPACEJOIST METAL WEBS MANUFACTURED BY TRUSWAL SYSTEMS CORPORATION.

WARNING Read all notes on this sheet and give a copy of it to the Erecting Contractor.

This design is for an individual building component, not a truss system. It has been based on specifications provided by the component manufacturer and has been completed in accordance with the current versions of TPI and AFPA design standards. No responsibility is assumed for dimensional accuracy. Dimensions are to be verified by the component manufacturer and/or building designer prior to fabrication. The building designer shall ascertain that the loads lateralized on this design meet or exceed the loading imposed by the local building code and the particular application. This design assumes that the top chord is laterally braced by the roof or floor sheathing and that the bottom chord is laterally braced by a rigid sheathing material directly attached, unless otherwise noted. Bracing shown is for lateral support of individual component members only. This component shall not be placed in any environment that will cause the moisture content of the wood to exceed 19% and/or cause connector plate corrosion. Fabricate, handle, install, and brace this truss in accordance with the following standards: SPACEJOIST TRUSS FABRICATION MANUAL, by Truswal Systems; Handling, Installing, and Bracing Metal Plate Connected Wood Trusses (HIB-91 and HIB-91 Summary Sheet) by TPI. The Truss Plate Institute is located at 583 Donofrio Dr., Ste. 200, Madison, WI 53719. The American Forest and Paper Association (AFPA) is located at 1111 19th St. N.W., Ste. 800, Washington, DC 20036.

Chk: _____
 Dsgnr: DL

Customer Name:
 SpaceJoist TE

DATE: 01/14/03

DESIGNED BY TRUSWAL SYSTEMS

TC Live	40 psf	DurFacs: L= 1.00 P= 1.00
TC Dead	See Span Table	Rep Mbr Bnd: 1.15
BC Live	0 psf	Spacing: See Span Table
BC Dead	5 psf	Design Spec: TPI
TOTAL See Span Table		

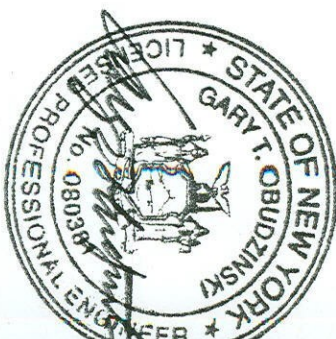

NOV 13 2003

OSB: SEE TX96284011-001
 FOR SPACEJOIST TE
 ASSEMBLY NOTES



1101 North Great Southwest Parkway
 Arlington, Texas 76011

TOP CHORD 3X2 SPF CAN. 2100F-1.8E
 BOTTOM CHORD 3X2 SPF CAN. 2100F-1.8E
 LUMBER SHEAR ALLOWABLES ARE PER NDS-1997

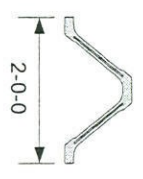
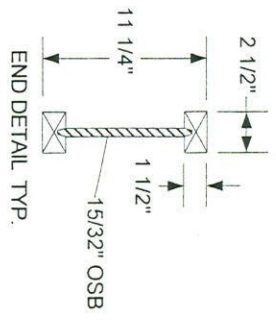

THIS TRUSS IS TRIMMABLE
 UP TO 12" MAY BE FIELD-TRIMMED
 FROM EACH END OF THIS TRUSS

SEE TX96284011-001 FOR SPACEJOIST TE
 ASSEMBLY AND GENERAL NOTES

LOADING, PSF	11 1/4" SPACEJOIST TE MAXIMUM SPANS			
	DEFLECTION RATIO	SPACING		
40-10-5	L/480	24" o.c.	19.2" o.c.	16" o.c.
	L/360	16'-10"	18'-3"	19'-2"
40-20-5	L/480	17'-9"	19'-11"	21'-0"
	L/360	14'-0"	18'-0"	21'-2"
		14'-0"	18'-0"	22'-0"

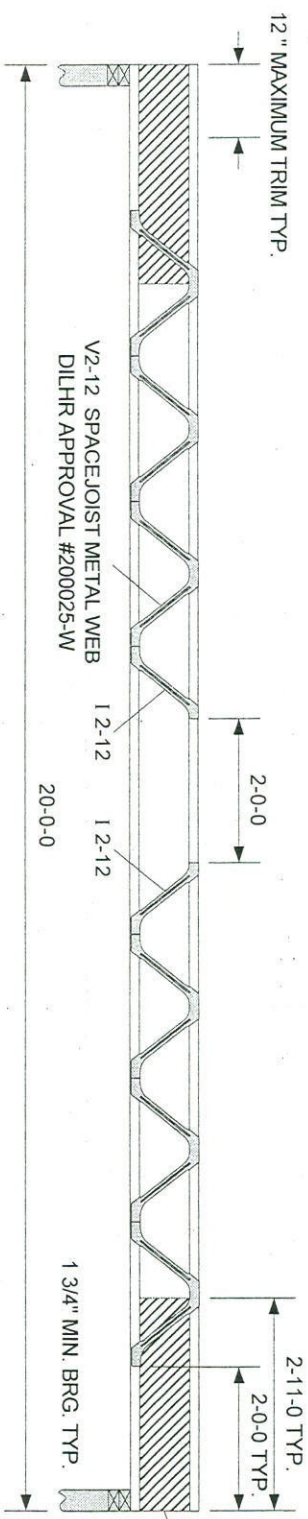

OSB: SEE TX96284011-001
 FOR SPACEJOIST TE
 ASSEMBLY NOTES

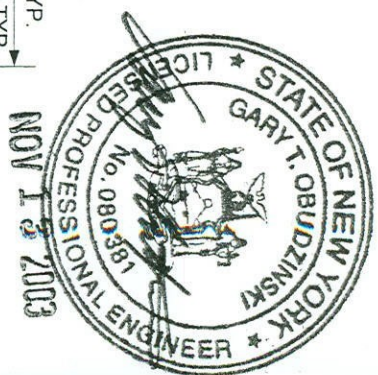

ALL WEBS ARE 20 GAUGE SPACEJOIST METAL WEBS MANUFACTURED BY TRUSMAL SYSTEMS CORPORATION.

WARNING Read all notes on this sheet and give a copy of it to the Erecting Contractor.

This design is for an individual building component, not a truss system. It has been based on specifications provided by the component manufacturer and has been completed in accordance with the current versions of TPI and AFPA design standards. No responsibility is assumed for dimensional accuracy. Dimensions are to be verified by the component manufacturer and/or building designer prior to fabrication. The building designer shall ascertain that the loads utilized on this design meet or exceed the loading imposed by the local building code and the particular application. This design assumes that the top chord is laterally braced by the roof or floor sheathing and that the bottom chord is laterally braced by a rigid sheathing material directly attached, unless otherwise noted. Bracing shown is for lateral support of individual component members only. This component shall not be placed in any environment that will cause the moisture content of the wood to exceed 19% and/or cause connector plate corrosion. Fabricate, handle, install, and brace this truss in accordance with the following standards: SPACEJOIST TRUSS FABRICATION MANUAL, by Trusmal Systems; Handling, Installing, and Bracing Metal Plate Connected Wood Trusses (HIB-91 and HIB-91 Summary Sheet) by TPI. The Truss Plate Institute is located at 583 D'Onofrio Dr., Ste. 200, Madison, WI 53719. The American Forest and Paper Association (AFPA) is located at 1111 19th St. N.W., Ste. 800, Washington, DC 20036.

CHK: _____	Customer Name: SpaceJoist TE
Dsgnr: DL	DurFacs: L = 1.00 P = 1.00
TC Live 40 psf	Rep Mbr Brd: 1.15
TC Dead See Span Table	Spacing: See Span Table
BC Live 0 psf	Design Spec: TPI
BC Dead 5 psf	
TOTAL See Span Table	

DATE: 01/14/03

DESIGNED BY TRUSMAL SYSTEMS



1101 North Great Southwest Parkway
 Arlington, Texas 76011

TOP CHORD 3X2 SPF CAN. 2100F-1.8E
 BOTTOM CHORD 3X2 SPF CAN. 2100F-1.8E
 LUMBER SHEAR ALLOWABLES ARE PER NDS-1997

LOADING, PSF	1 1/4" SPACEJOIST TE MAXIMUM SPANS			
	DEFLECTION RATIO	SPACING		
40-10-5	L/480	24" O.C.	19.2" O.C.	16" O.C.
	L/360	16'-10"	18'-3"	19'-2"
40-20-5	L/480	17'-9"	19'-11"	21'-0"
	L/360	14'-0"	18'-0"	21'-2"
		14'-0"	18'-0"	20'-2"
				22'-0"

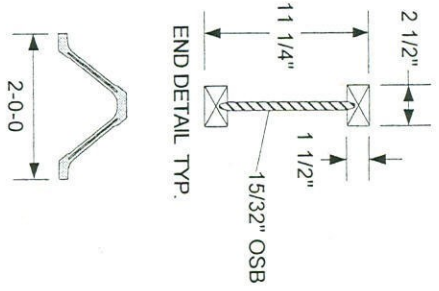

THIS TRUSS IS TRIMMABLE
 UP TO 12" MAY BE FIELD-TRIMMED
 FROM EACH END OF THIS TRUSS

SEE TX96284011-001 FOR SPACEJOIST TE
 ASSEMBLY AND GENERAL NOTES



NOV 13 2003

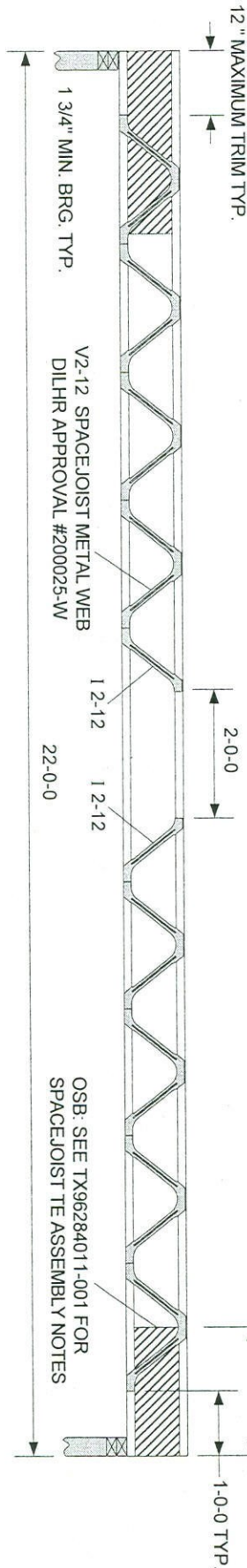

ALL WEBS ARE 20 GAUGE SPACEJOIST METAL WEBS MANUFACTURED BY TRUSWAL SYSTEMS CORPORATION.

WARNING Read all notes on this sheet and give a copy of it to the Erecting Contractor.

This design is for an individual building component, not a truss system. It has been based on specifications provided by the component manufacturer and has been completed in accordance with the current versions of TPI and AFPA design standards. No responsibility is assumed for dimensional accuracy.

Dimensions are to be verified by the component manufacturer and/or building designer prior to fabrication. The building designer shall ascertain that the loads utilized on this design meet or exceed the loading imposed by the local building code and the particular application. This design assumes that the top chord is laterally braced by the roof or floor sheathing and that the bottom chord is laterally braced by a rigid sheathing material directly attached, unless otherwise noted. Bracing shown is for lateral support of individual component members only. This component shall not be placed in any environment that will cause the moisture content of the wood to exceed 19% and/or cause connector plate corrosion. Fabricate, handle, install, and brace this truss in accordance with the following standards: SPACEJOIST TRUSS FABRICATION MANUAL, by Truswal Systems; Handling, Installing, and Bracing Metal Plate Connected Wood Trusses (HB-91 and HB-91 Summary Sheet) by TPI. The Truss Plate Institute is located at 583 D'Onofrio Dr., Ste. 200, Madison, WI 53719. The American

standards: HB-91 and HB-91 Summary Sheet by TPI. The Truss Plate Institute is located at 583 D'Onofrio Dr., Ste. 200, Madison, WI 53719. The American

CHK:	Customer Name:
Design: DL	SpaceJoist TE
TC Live 40 psf	DurFacs: L= 1.00 P= 1.00
TC Dead See Span Table	Rep Mbr Bnd: 1.15
BC Live 0 psf	Spacing: See Span Table
BC Dead 5 psf	Design Spec: TPI

DATE: 01/14/03
 DESIGNED BY TRUSWAL SYST



Trimtable End

SpaceJoist™

1101 North Great Southwest Parkway
 Arlington, Texas 76011

TOP CHORD 3X2 SPF CAN. 1650F-1.5E
 BOTTOM CHORD 3X2 SPF CAN. 1650F-1.5E
 LUMBER SHEAR ALLOWABLES ARE PER NDS-1997

LOADING, PSF	14" SPACEJOIST TE MAXIMUM SPANS			
	SPACING			
DEFLECTION RATIO	24" O.C.	19.2" O.C.	16" O.C.	12" O.C.
40-10-5	L/480	20'-1"	21'-5"	22'-9"
	L/360	20'-1"	22'-7"	24'-0"
40-20-5	L/480	16'-0"	20'-0"	22'-8"
	L/360	16'-0"	20'-0"	24'-0"

THIS TRUSS IS TRIMMABLE
 UP TO 18" MAY BE FIELD-TRIMMED
 FROM EACH END OF THIS TRUSS

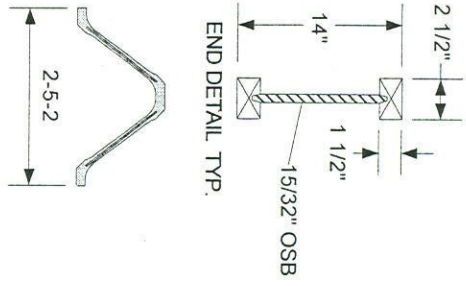

SEE TX96284011-001 FOR SPACEJOIST TE ASSEMBLY AND GENERAL NOTES

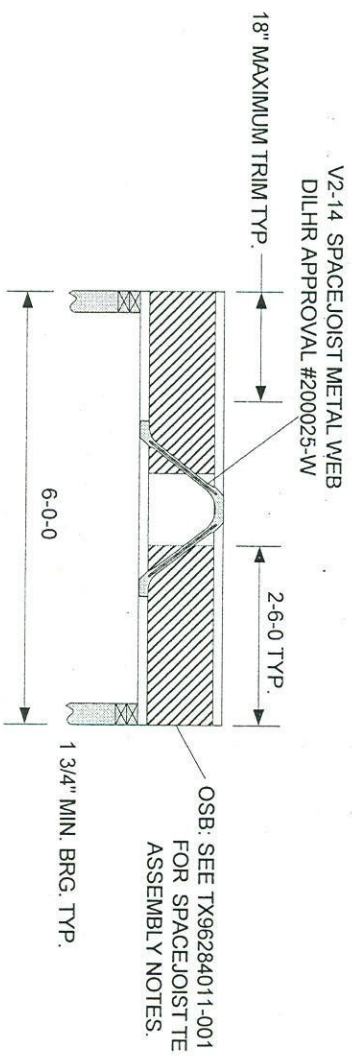

ALL WEBS ARE 20 GAUGE SPACEJOIST METAL WEBS MANUFACTURED BY TRUSSAL SYSTEMS CORPORATION.

WARNING Read all notes on this sheet and give a copy of it to the Erecting Contractor.

This design is for an individual building component, not a truss system. It has been based on specifications provided by the component manufacturer and has been completed in accordance with the current versions of TPI and AFPA design standards. No responsibility is assumed for dimensional accuracy. Dimensions are to be verified by the component manufacturer and/or building designer prior to fabrication. The building designer shall ascertain that the loads utilized on this design meet or exceed the loading imposed by the local building code and the particular application. This design assumes that the top chord is laterally braced by the roof or floor sheathing and that the bottom chord is laterally braced by a rigid sheathing material directly attached, unless otherwise noted. Bracing shown is for lateral support of individual component members only. This component shall not be placed in any environment that will cause the moisture content of the wood to exceed 19% and/or cause connector plate corrosion. Fabricate, handle, install, and brace this truss in accordance with the following standards: SPACEJOIST TRUSS FABRICATION MANUAL, by Trussal Systems; Handling, Installing, and Bracing Metal Plate Connected Wood Trusses (HIB-91 and HIB-91 Summary Sheet) by TPI. The Truss Plate Institute is located at 583 D'Onofrio Dr., Ste. 200, Madison, WI 53719. The American Forest and Paper Association (AFPA) is located at 1111 19th St. N.W., Ste. 800, Washington, DC 20036.

NOV 19 2003

DATE: 01/14/03
 Designed by Trussal Systems

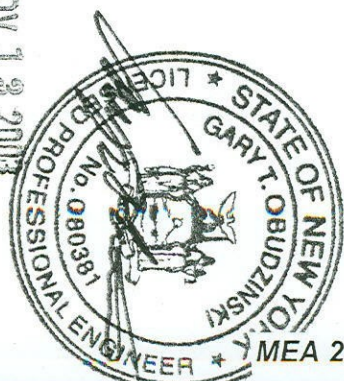

1101 North Great Southwest Parkway
 Arlington, Texas 76011

CHK: Degr.: DL	Customer Name: SpaceJoist TE
TC Live 40 psf	DurFacs: L= 1.00 P= 1.00
TC Dead See Span Table	Rep Mbr End: 1.15
BC Live 0 psf	Spacing: See Span Table
BC Dead 5 psf	Design Spec: TPI
TOTAL See Span Table	

TOP CHORD 3X2 SPF CAN. 1650F-1.5E
 BOTTOM CHORD 3X2 SPF CAN. 1650F-1.5E
 LUMBER SHEAR ALLOWABLES ARE PER NDS-1997

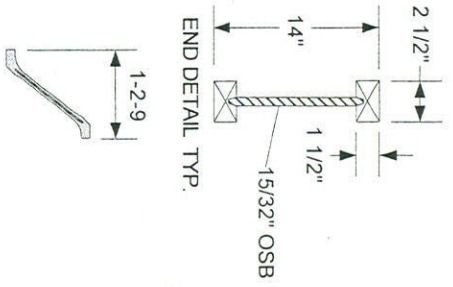

THIS TRUSS IS TRIMMABLE
 UP TO 12" MAY BE FIELD-TRIMMED
 FROM EACH END OF THIS TRUSS

SEE TX96284011-001 FOR SPACEJOIST TE
 ASSEMBLY AND GENERAL NOTES

LOADING, PSF	14" SPACEJOIST TE MAXIMUM SPANS				
	SPACING				
	DEFLECTION RATIO	24" O.C.	19.2" O.C.	16" O.C.	12" O.C.
40-10-5	L/480	20'-1"	21'-5"	22'-9"	24'-0"
	L/360	20'-1"	22'-7"	24'-0"	24'-0"
40-20-5	L/480	16'-0"	20'-0"	22'-8"	24'-0"
	L/360	16'-0"	20'-0"	22'-8"	24'-0"

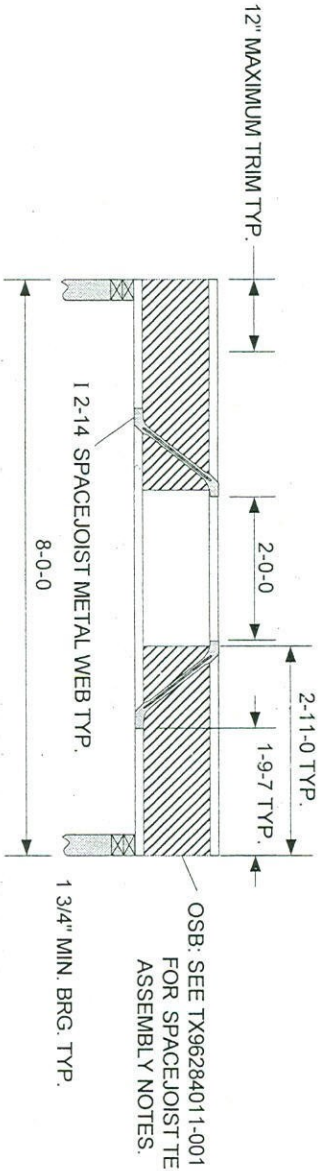

ALL WEBS ARE 20 GAUGE SPACEJOIST METAL WEBS MANUFACTURED BY TRUSWAL SYSTEMS CORPORATION.

WARNING Read all notes on this sheet and give a copy of it to the Erecting Contractor.

This design is for an individual building component, not a truss system. It has been based on specifications provided by the component manufacturer and has been completed in accordance with the current versions of TPI and AFPA design standards. No responsibility is assumed for dimensional accuracy. Dimensions are to be verified by the component manufacturer and/or building designer prior to fabrication. The building designer shall ascertain that the loads utilized on this design meet or exceed the loading imposed by the local building code and the particular application. This design assumes that the top chord is laterally braced by the roof or floor sheathing and that the bottom chord is laterally braced by a rigid sheathing material directly attached, unless otherwise noted. Bracing shown is for lateral support of individual component members only. This component shall not be placed in any environment that will cause the moisture content of the wood to exceed 19% and/or cause connector plate corrosion. Fabricate, handle, install, and brace this truss in accordance with the following standards: SPACEJOIST TRUSS FABRICATION MANUAL, by Truswal Systems; Handling, Installing, and Bracing Metal Plate Connected Wood Trusses (HIB-91 and HIB-91 Summary Sheet) by TPI. The Truss Plate Institute is located at 583 D'Onofrio Dr., Ste. 200, Madison, WI 53719. The American Forest and Paper Association (AFPA) is located at 1111 19th St. N.W., Ste. 800, Washington, DC 20036.

NOV 13 2003



DATE: 01/14/03
 Designed by Truswal Systems



1101 North Great Southwest Parkway
 Arlington, Texas 76011

CHK: Design: DL	Customer Name: SpaceJoist TE
TC Live 40 psf	DurFacs: L = 1.00 P = 1.00
TC Dead See Span Table	Rep Mbr Bnd: 1.15
BC Live 0 psf	Spacing: See Span Table
BC Dead 5 psf	Design Spec: TPI
TOTAL See Span Table	

TOP CHORD 3X2 SPF CAN. 1650F-1.5E
 BOTTOM CHORD 3X2 SPF CAN. 1650F-1.5E
 LUMBER SHEAR ALLOWABLES ARE PER NDS-1997

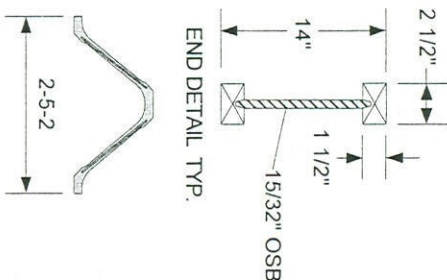

THIS TRUSS IS TRIMMABLE
 UP TO 12" MAY BE FIELD-TRIMMED
 FROM EACH END OF THIS TRUSS

SEE TX96284011-001 FOR SPACEJOIST TE
 ASSEMBLY AND GENERAL NOTES

LOADING, PSF	14" SPACEJOIST TE MAXIMUM SPANS			
	DEFLECTION RATIO	SPACING		
40-10-5	L/480	24" o.c.	19.2" o.c.	16" o.c.
	L/360	20'-1"	21'-5"	22'-9"
40-20-5	L/480	20'-1"	22'-7"	24'-0"
	L/360	16'-0"	20'-0"	22'-8"

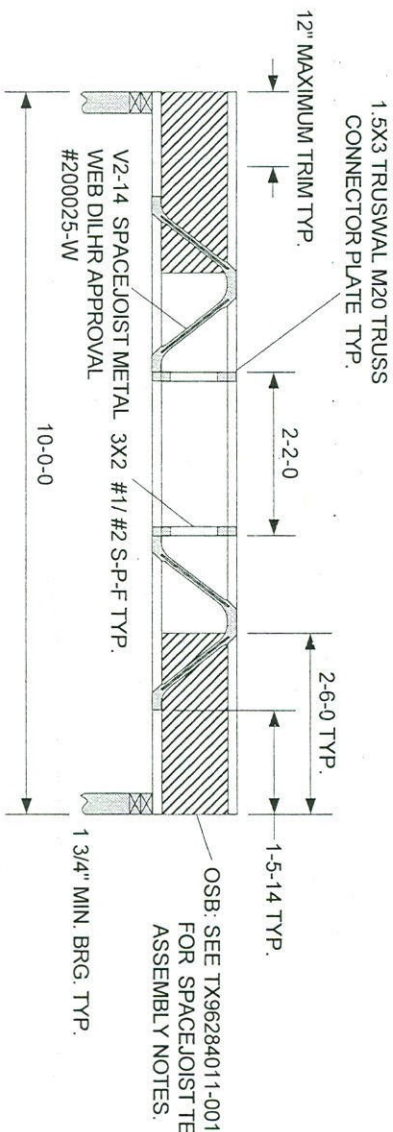

ALL WEBS ARE 20 GAUGE SPACEJOIST METAL WEBS MANUFACTURED BY TRUSSWAL SYSTEMS CORPORATION.

WARNING Read all notes on this sheet and give a copy of it to the Erecting Contractor.

This design is for an individual building component, not a truss system. It has been based on specifications provided by the component manufacturer and has been completed in accordance with the current versions of TPI and AFPA design standards. No responsibility is assumed for dimensional accuracy. Dimensions are to be verified by the component manufacturer and/or building designer prior to fabrication. The building designer shall ascertain that the loads utilized on this design meet or exceed the loading imposed by the local building code and the particular application. This design assumes that the top chord is laterally braced by the roof or floor sheathing and that the bottom chord is laterally braced by a rigid sheathing material directly attached, unless otherwise noted. Bracing shown is for lateral support of individual component members only. This component shall not be placed in any environment that will cause the moisture content of the wood to exceed 19% and/or cause connector plate corrosion. Fabricate, handle, install, and brace this truss in accordance with the following standards: SPACEJOIST TRUSS FABRICATION MANUAL, by Trusswal Systems; Handling, Installing, and Bracing Metal Plate Connected Wood Trusses (HIB-91 and HIB-91 Summary Sheet) by TPI. The Truss Plate Institute is located at 583 D'Onofrio Dr., Ste. 200, Madison, WI 53719. The American Forest and Paper Association (AFPA) is located at 1111 19th St. N.W., Ste. 800, Washington, DC 20036.



1101 North Great Southwest Parkway
 Arlington, Texas 76011

NOV 19 2003

DATE: 01/14/03
 Designed by Trusswal Systems



MEA 262-03-E

CHK: Dsgnr: DL

Customer Name: SpaceJoist TE

TC Live	40 psf	DurFacs: L = 1.00 P = 1.00
TC Dead	See Span Table	Rep Mbr Bnd: 1.15
BC Live	0 psf	Spacing: See Span Table
BC Dead	5 psf	Design Spec: TPI

TOTAL See Span Table

TOP CHORD 3X2 SPF CAN. 1650F-1.5E
 BOTTOM CHORD 3X2 SPF CAN. 1650F-1.85E
 LUMBER SHEAR ALLOWABLES ARE PER NDS-1997

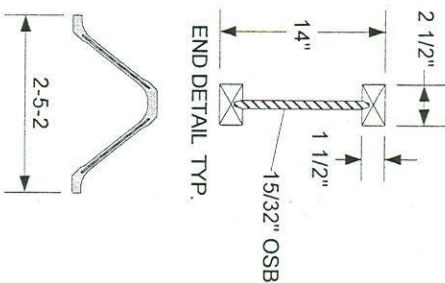

THIS TRUSS IS TRIMMABLE
 UP TO 12" MAY BE FIELD-TRIMMED
 FROM EACH END OF THIS TRUSS

SEE TX96284011-001 FOR SPACEJOIST TE
 ASSEMBLY AND GENERAL NOTES

LOADING, PSF	14" SPACEJOIST TE MAXIMUM SPANS		
	DEFLECTION RATIO	SPACING	
40-10-5	L/480	24" o.c.	12" o.c.
	L/360	20'-1"	24'-0"
40-20-5	L/480	20'-0"	24'-0"
	L/360	16'-0"	22'-8"

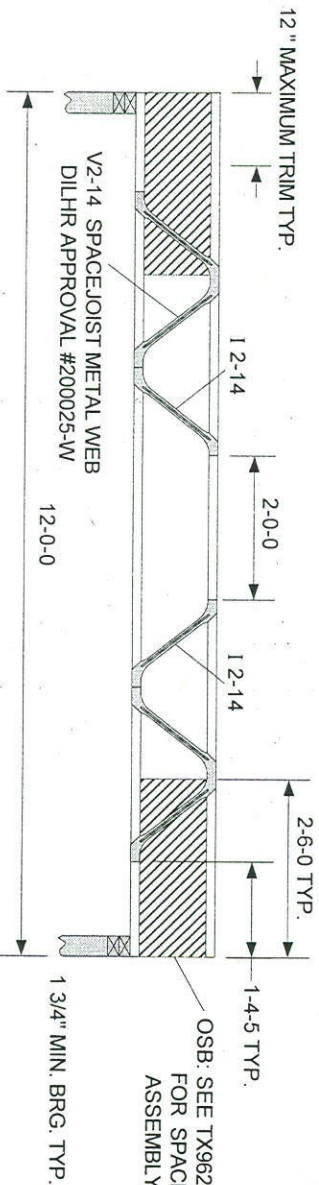

OSB: SEE TX96284011-001
 FOR SPACEJOIST TE
 ASSEMBLY NOTES.

NOV 13 2003



ALL WEBS ARE 20 GAUGE SPACEJOIST METAL WEBS MANUFACTURED BY TRUSSAL SYSTEMS CORPORATION.

WARNING Read all notes on this sheet and give a copy of it to the Erecting Contractor.

This design is for an individual building component, not a truss system. It has been based on specifications provided by the component manufacturer and has been completed in accordance with the current versions of TPI and AFPA design standards. No responsibility is assumed for dimensional accuracy. Dimensions are to be verified by the component manufacturer and/or building designer prior to fabrication. The building designer shall ascertain that the loads utilized on this design meet or exceed the loading imposed by the local building code and the particular application. This design assumes that the top chord is laterally braced by the roof or floor sheathing and that the bottom chord is laterally braced by a rigid sheathing material directly attached, unless otherwise noted. Bracing shown is for lateral support of individual component members only. This component shall not be placed in any environment that will cause the moisture content of the wood to exceed 19% and/or cause connector plate corrosion. Fabricate, handle, install, and brace this truss in accordance with the following standards: SPACEJOIST TRUSS FABRICATION MANUAL by Trussal Systems; Handling, Installing, and Bracing Metal Plate Connected Wood Trusses (HIB-91 and HIB-91 Summary Sheet) by TPI. The Truss Plate Institute is located at 583 D'Onofrio Dr., Ste. 200, Madison, WI 53719. The American Forest and Paper Association (AFPA) is located at 1111 19th St. N.W., Ste. 800, Washington, DC 20036.

Trimable End

SpaceJoist™

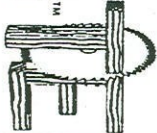

1101 North Great Southwest Parkway
 Arlington, Texas 76011

CHK: Dsgnr: DL	Customer Name: SpaceJoist TE
TC Live 40 psf	DurFacs: L= 1.00 P= 1.00
TC Dead See Span Table	Rep Mbr Bnd: 1.15
BC Live 0 psf	Spacing: See Span Table
BC Dead 5 psf	Design Spec: TPI
TOTAL See Span Table	

DATE: 01/14/03
 Designed by Trussal System

TOP CHORD 3X2 SPF CAN. 2100F-1.8E
 BOTTOM CHORD 3X2 SPF CAN. 2100F-1.8E
 LUMBER SHEAR ALLOWABLES ARE PER NDS-1997

LOADING, PSF	14" SPACEJOIST TE MAXIMUM SPANS			
	DEFLECTION RATIO		SPACING	
40-10-5	L/480	24" O.C.	19.2" O.C.	16" O.C.
	L/360	20'-1"	21'-5"	22'-9"
40-20-5	L/480	16'-0"	20'-0"	22'-8"
	L/360	16'-0"	20'-0"	24'-0"

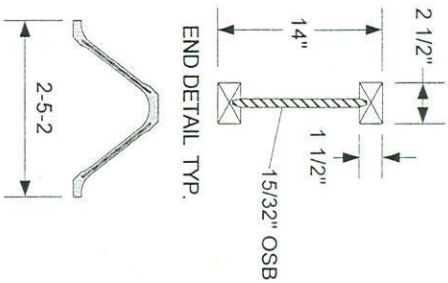

THIS TRUSS IS TRIMMABLE
 UP TO 12" MAY BE FIELD-TRIMMED
 FROM EACH END OF THIS TRUSS

SEE TX96284011-001 FOR SPACEJOIST TE ASSEMBLY AND GENERAL NOTES

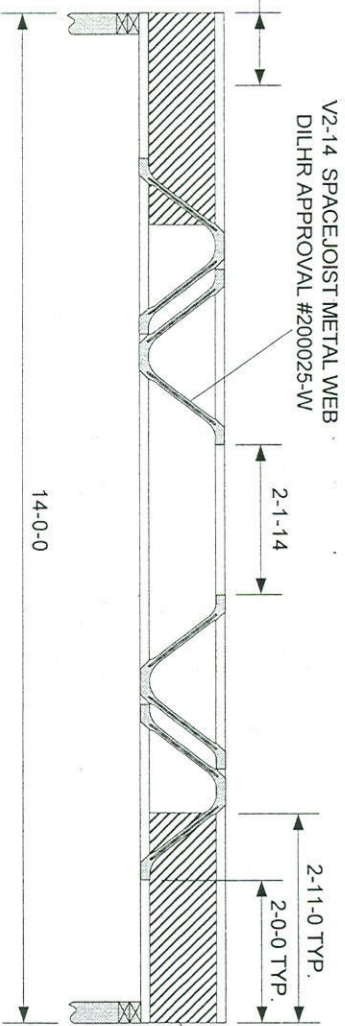

OSB: SEE TX96284011-001 FOR SPACEJOIST TE ASSEMBLY NOTES.



NOV 13 2003

ALL WEBS ARE 20 GAUGE SPACEJOIST METAL WEBS MANUFACTURED BY TRUSSAL SYSTEMS CORPORATION.

WARNING Read all notes on this sheet and give a copy of it to the Erecting Contractor.

This design is for an individual building component, not a truss system. It has been based on specifications provided by the component manufacturer and has been completed in accordance with the current versions of TPI and AFPA design standards. No responsibility is assumed for dimensional accuracy. Dimensions are to be verified by the component manufacturer and/or building designer prior to fabrication. The building designer shall ascertain that the loads utilized on this design meet or exceed the loading imposed by the local building code and the particular application. This design assumes that the top chord is laterally braced by the roof or floor sheathing and that the bottom chord is laterally braced by a rigid sheathing material directly attached, unless otherwise noted. Bracing shown is for lateral support of individual component members only. This component shall not be placed in any environment that will cause the moisture content of the wood to exceed 19% and/or cause connector plate corrosion. Fabricate, handle, install, and brace this truss in accordance with the following standards: SPACEJOIST TRUSS FABRICATION MANUAL, by Trussal Systems; Handling, Installing, and Bracing Metal Plate Connected Wood Trusses (HB-91 and HB-91 Summary Sheet) by TPI. The Truss Plate Institute is located at 583 D'Onofrio Dr., Ste. 200, Madison, WI 53719. The American Forest and Paper Association (AFPA) is located at 1111 19th St. N.W., Ste. 800, Washington, DC 20036.

CHK:	Customer Name:
Dsgnr: DL	SpaceJoist TE
TC Live	40 psf
TC Dead	See Span Table
BC Live	0 psf
BC Dead	5 psf
TOTAL	See Span Table
DurFacs: L=1.00 P=1.00	
Rep Mbr Brd: 1.15	
Spacing: See Span Table	
Design Spec: TPI	

DATE: 01/14/03
 Designed by Trussal Systems



1101 North Great Southwest Parkway
 Arlington, Texas 76011

Job Name: SpaceJoist TE

Truss ID: TE14-16N

Drwg: TX03014021-025

QG NR-1F

TOP CHORD 3X2 SPF CAN. 2100F-1.8E
 BOTTOM CHORD 3X2 SPF CAN. 2100F-1.8E
 LUMBER SHEAR ALLOWABLES ARE PER NDS-1997

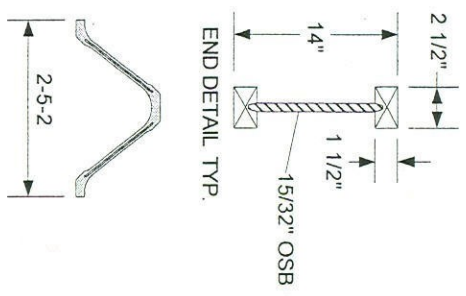

THIS TRUSS IS TRIMMABLE
 UP TO 12" MAY BE FIELD-TRIMMED
 FROM EACH END OF THIS TRUSS

SEE TX96284011-001 FOR SPACEJOIST TE
 ASSEMBLY AND GENERAL NOTES

LOADING, PSF	14" SPACEJOIST TE MAXIMUM SPANS				
	SPACING				
	DEFLECTION RATIO	24" o.c.	19.2" o.c.	16" o.c.	12" o.c.
40-10-5	L/480	20'-1"	21'-5"	22'-9"	24'-0"
	L/360	20'-1"	22'-7"	24'-0"	24'-0"
40-20-5	L/480	16'-0"	20'-0"	22'-8"	24'-0"
	L/360	16'-0"	20'-0"	22'-8"	24'-0"

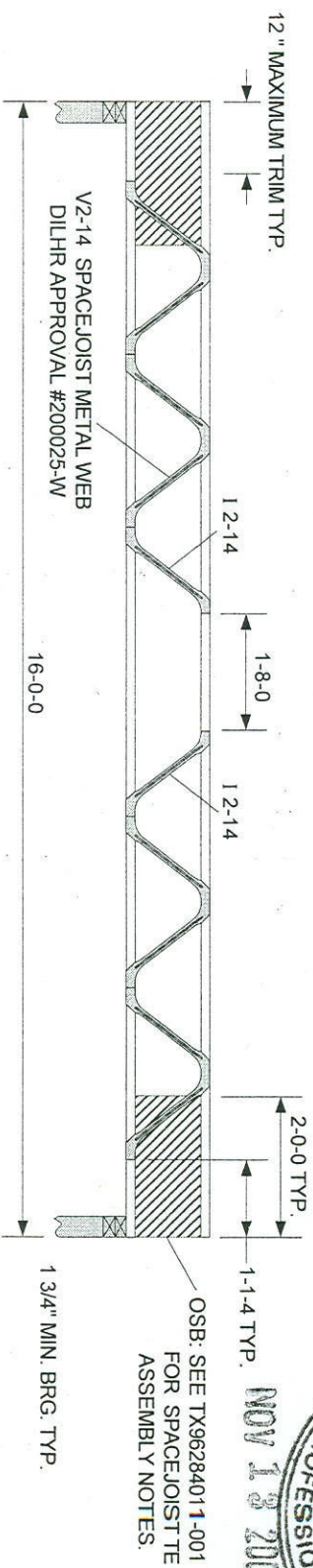

NOV 13 2003



ALL WEBS ARE 20 GAUGE SPACEJOIST METAL WEBS MANUFACTURED BY TRUSSAL SYSTEMS CORPORATION.

WARNING Read all notes on this sheet and give a copy of it to the Erecting Contractor.

This design is for an individual building component, not a truss system. It has been based on specifications provided by the component manufacturer and has been completed in accordance with the current versions of TPI and AFPA design standards. No responsibility is assumed for dimensional accuracy. Dimensions are to be verified by the component manufacturer and/or building designer prior to fabrication. The building designer shall ascertain that the loads utilized on this design meet or exceed the loading imposed by the local building code and the particular application. This design assumes that the top chord is laterally braced by the roof or floor sheathing and that the bottom chord is laterally braced by a rigid sheathing material directly attached, unless otherwise noted. Bracing shown is for lateral support of individual component members only. This component shall not be placed in any environment that will cause the moisture content of the wood to exceed 19% and/or cause connector plate corrosion. Fabricate, handle, install, and brace this truss in accordance with the following standards: SPACEJOIST TRUSS FABRICATION MANUAL, by Trussal Systems; Handling, Installing, and Bracing Metal Plate Connected Wood Trusses (HLB-91 and HLB-91 Summary Sheet) by TPI. The Truss Plate Institute is located at 583 D'Onofrio Dr., Ste. 200, Madison, WI 53719. The American Forest and Paper Association (AFPA) is located at 1111 19th St. N.W., Ste. 800, Washington, DC 20036.

CHK:	Customer Name:	SpaceJoist TE
Dsgn: DL		
TC Live	40 psf	DurFacs: L = 1.00 P = 1.00
TC Dead	See Span Table	Rep Mbr Bnd: 1.15
BC Live	0 psf	Spacing: See Span Table
BC Dead	5 psf	Design Spec: TPI
TOTAL	See Span Table	

Trimable End
SpaceJoist™
 1101 North Great Southwest Parkway
 Arlington, Texas 76011

Job Name: **SpaceJoist TE**

Truss ID: **TE14-18N**

Drwg: **TX03014021-026**

QGNR-1F

TOP CHORD 3X2 SPF CAN 2100F-1.8E
 BOTTOM CHORD 3X2 SPF CAN 2100F-1.8E
 LUMBER SHEAR ALLOWABLES ARE PER NDS-1997

LOADING, PSF	DEFLECTION RATIO	14" SPACEJOIST TE MAXIMUM SPANS			
		SPACING			
40-10-5	L/480	24" o.c.	19.2" o.c.	16" o.c.	12" o.c.
		L/360	20'-1"	22'-7"	24'-0"
40-20-5	L/480	16'-0"	20'-0"	22'-8"	24'-0"
		L/360	16'-0"	20'-0"	24'-0"

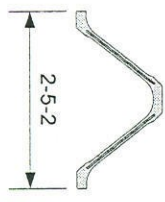
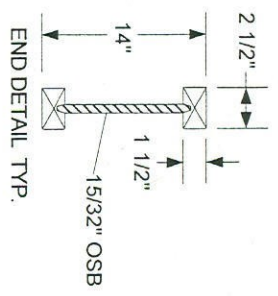

THIS TRUSS IS TRIMMABLE
 UP TO 12" MAY BE FIELD-TRIMMED
 FROM EACH END OF THIS TRUSS

SEE TX96284011-001 FOR SPACEJOIST TE
 ASSEMBLY AND GENERAL NOTES

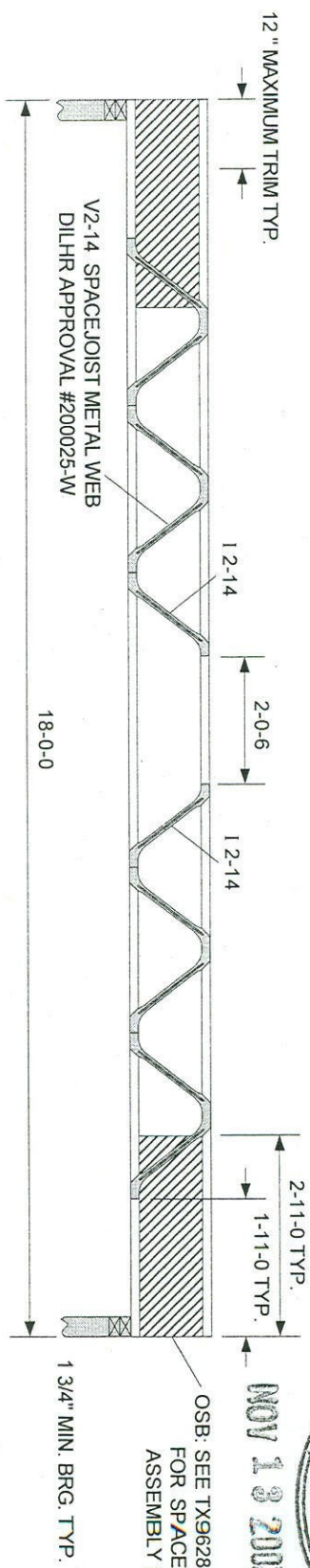

NOV 13 2003

OSB: SEE TX96284011-001
 FOR SPACEJOIST TE
 ASSEMBLY NOTES.

ALL WEBS ARE 20 GAUGE SPACEJOIST METAL WEBS MANUFACTURED BY TRUSWAL SYSTEMS CORPORATION.

WARNING Read all notes on this sheet and give a copy of it to the Erecting Contractor.

This design is for an individual building component, not a truss system. It has been based on specifications provided by the component manufacturer and has been completed in accordance with the current versions of TPI and AFPA design standards. No responsibility is assumed for dimensional accuracy. Dimensions are to be verified by the component manufacturer and/or building designer prior to fabrication. The building designer shall ascertain that the loads utilized on this design meet or exceed the loading imposed by the local building code and the particular application. This design assumes that the top chord is laterally braced by the roof or floor sheathing and that the bottom chord is laterally braced by a rigid sheathing material directly attached, unless otherwise noted. Bracing shown is for lateral support of individual component members only. This component shall not be placed in any environment that will cause the moisture content of the wood to exceed 19% and/or cause connector plate corrosion. Fabricate, handle, install, and brace this truss in accordance with the following standards: *SPACEJOIST TRUSS FABRICATION MANUAL*, by Trussal Systems; *Handling, Installing, and Bracing Metal Plate Connected Wood Trusses* (HIB-91 and HIB-91 Summary Sheet) by TPI. The Truss Plate Institute is located at 583 D'Onofrio Dr., Ste. 200, Madison, WI 53719. The American Forest and Paper Association (AFPA) is located at 1111 19th St. N.W., Ste. 800, Washington, DC 20036.

Chk: Dsgnr: DL	Customer Name: SpaceJoist TE
TC Live 40 psf	DurFacs: L=1.00 P=1.00
TC Dead See Span Table	Rep Mbr Bnd: 1.15
BC Live 0 psf	Spacing: See Span Table
BC Dead 5 psf	Design Spec: TPI
TOTAL See Span Table	

DATE: 01/14/03
 Designed by Trusswal System

MEA 262-03-E

Trimable End
SpaceJoist™
 1101 North Great Southwest Parkway
 Arlington, Texas 76011



TOP CHORD 3X2 SPF CAN. 2100F-1.8E
 BOTTOM CHORD 3X2 SPF CAN. 2100F-1.8E
 LUMBER SHEAR ALLOWABLES ARE PER NDS-1997

LOADING, PSF	14" SPACEJOIST TE MAXIMUM SPANS			
	DEFLECTION RATIO		SPACING	
40-10-5	L/480	24" o.c.	19.2" o.c.	16" o.c.
	L/360	20'-1"	21'-5"	22'-9"
40-20-5	L/480	20'-1"	22'-7"	24'-0"
	L/360	16'-0"	20'-0"	22'-8"
				24'-0"

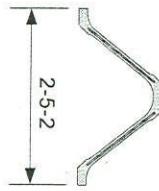
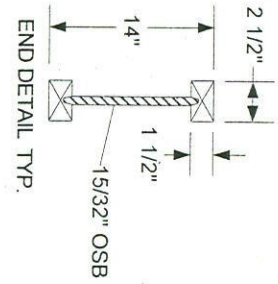

THIS TRUSS IS TRIMMABLE
 UP TO 12" MAY BE FIELD-TRIMMED
 FROM EACH END OF THIS TRUSS

SEE TX96284011-001 FOR SPACEJOIST TE
 ASSEMBLY AND GENERAL NOTES

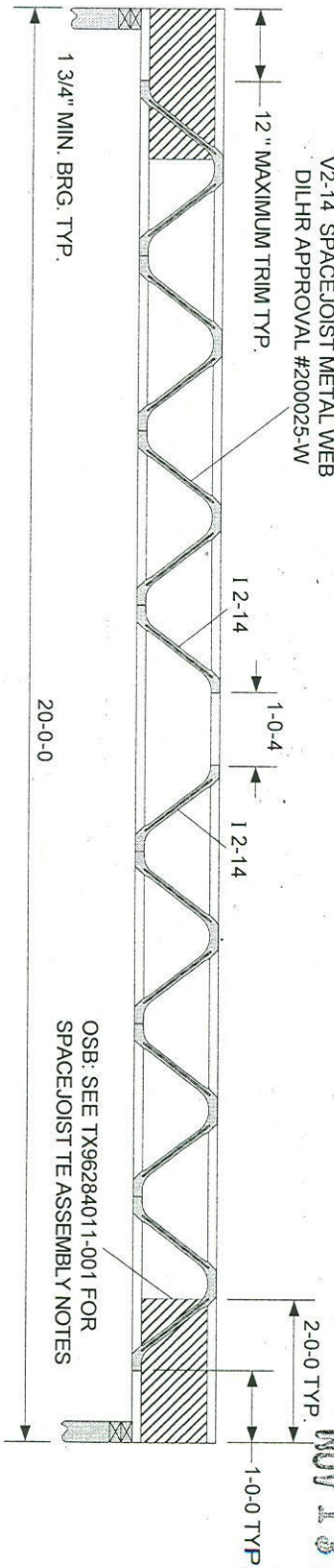

NOV 13 2003

ALL WEBS ARE 20 GAUGE SPACEJOIST METAL WEBS MANUFACTURED BY TRUSMAL SYSTEMS CORPORATION.

DATE: 01/14/03
 Designed by Trussval Syste

WARNING Read all notes on this sheet and give a copy of it to the Erecting Contractor.

This design is for an individual building component, not a truss system. It has been based on specifications provided by the component manufacturer and has been completed in accordance with the current versions of TPI and AFPA design standards. No responsibility is assumed for dimensional accuracy. Dimensions are to be verified by the component manufacturer and/or building designer prior to fabrication. The building designer shall ascertain that the loads utilized on this design meet or exceed the loading imposed by the local building code and the particular application. This design assumes that the top chord is laterally braced by the roof or floor sheathing and that the bottom chord is laterally braced by a rigid sheathing material directly attached, unless otherwise noted. Bracing shown is for lateral support of individual component members only. This component shall not be placed in any environment that will cause the moisture content of the wood to exceed 19% and/or cause connector plate corrosion. Fabricate, handle, install, and brace this truss in accordance with the following standards: SPACEJOIST TRUSS FABRICATION MANUAL, by Trussval Systems; Handling, Installing, and Bracing Metal Plate Connected Wood Trusses (HB-91 and HB-91 Summary Sheet) by TPI; The Truss Plate Institute is located at 583 D'Oonofrio Dr., Ste. 200, Madison, WI 53719; The American Forest and Paper Association (AFPA) is located at 1111 19th St. N.W., Ste. 800, Washington, DC 20036.

CHK:		Customer Name:	SpaceJoist TE
Design: DL			
TC Live	40 psf	DurFacts: L= 1.00 P= 1.00	
TC Dead	See Span Table	Rep Mbr Bnd: 1.15	
BC Live	0 psf	Spacing: See Span Table	
BC Dead	5 psf	Design Spec: TPI	
TOTAL	See Span Table		

Trimable End
SpaceJoist
 1101 North Great Southwest Parkway
 Arlington, Texas 76011

TOP CHORD 3X2 SPF CAN. 2100F-1.8E
 BOTTOM CHORD 3X2 SPF CAN. 2100F-1.8E
 LUMBER SHEAR ALLOWABLES ARE PER NDS-1997

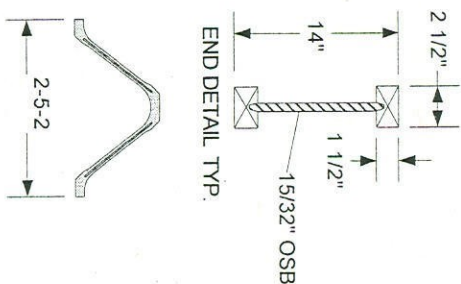

THIS TRUSS IS TRIMMABLE
 UP TO 12" MAY BE FIELD-TRIMMED
 FROM EACH END OF THIS TRUSS

SEE TX96284011-001 FOR SPACEJOIST TE
 ASSEMBLY AND GENERAL NOTES

LOADING, PSF	14" SPACEJOIST TE MAXIMUM SPANS			
	DEFLECTION RATIO	SPACING		
40-10-5	L/480	24" O.C.	19.2" O.C.	16" O.C.
	L/360	20'-1"	22'-7"	24'-0"
40-20-5	L/480	16'-0"	20'-0"	22'-8"
	L/360	16'-0"	20'-0"	24'-0"

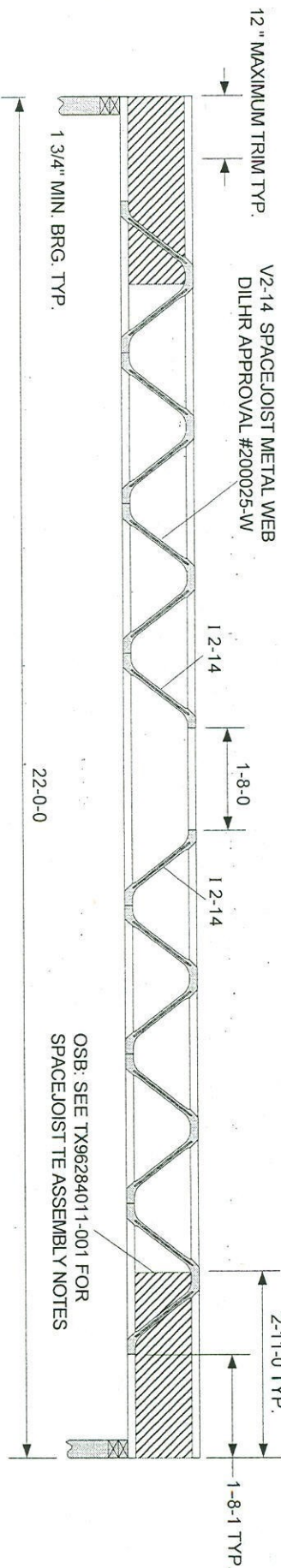

NOV 19 2003

ALL WEBS ARE 20 GAUGE SPACEJOIST METAL WEBS MANUFACTURED BY TRUSSAL SYSTEMS CORPORATION.

WARNING Read all notes on this sheet and give a copy of it to the Erecting Contractor.

This design is for an individual building component, not a truss system. It has been based on specifications provided by the component manufacturer and has been completed in accordance with the current versions of TPI and AFPA design standards. No responsibility is assumed for dimensional accuracy. Dimensions are to be verified by the component manufacturer and/or building designer prior to fabrication. The building designer shall ascertain that the loads laterally braced by the roof or floor sheathing and that the bottom chord is laterally braced by a rigid sheathing material directly attached, unless otherwise noted. Bracing shown is for lateral support of individual component members only. This component shall not be placed in any environment that will cause the moisture content of the wood to exceed 19% and/or cause connector plate corrosion. Fabricate, handle, install, and brace this truss in accordance with the following standards: SPACEJOIST TRUSS FABRICATION MANUAL, by Trussal Systems; Handling, Installing, and Bracing Metal Plate Connected Wood Trusses (HIB-91 and HIB-91 Summary Sheet) by TPI. The Truss Plate Institute is located at 583 D'Onofrio Dr., Ste. 200, Madison, WI 53719. The American Forest and Paper Association (AFPA) is located at 1111 19th St. N.W., Ste. 800, Washington, DC 20036.



1101 North Great Southwest Parkway
 Arlington, Texas 76011

DATE: 01/14/03
 Designed by Trussal System

CHK:	Customer Name:
Dsgnr: DL	SpaceJoist TE
TC Live	DurFacs: L=1.00 P=1.00
TC Dead	Rep Mbr Bnd: 1.15
BC Live	Spacing: See Span Table
BC Dead	Design Spec: TPI
TOTAL See Span Table	

Job Name: SpaceJoist TE

Truss ID: TE14-24N

Drwg: TX03014021-029

QG NR-1F

TOP CHORD 3X2 SPF CAN. 2100F-1.8E
 BOTTOM CHORD 3X2 SPF CAN. 2100F-1.8E
 LUMBER SHEAR ALLOWABLES ARE PER NDS-1997

LOADING, PSF	14" SPACEJOIST TE MAXIMUM SPANS			
	DEFLECTION RATIO			
40-10-5	L/480	24" O.C.	19.2" O.C.	16" O.C.
	L/360	20'-1"	21'-5"	22'-9"
	L/480	20'-1"	22'-7"	24'-0"
40-20-5	L/480	16'-0"	20'-0"	22'-8"
	L/360	16'-0"	20'-0"	24'-0"

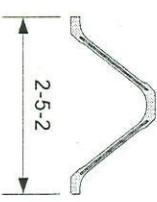
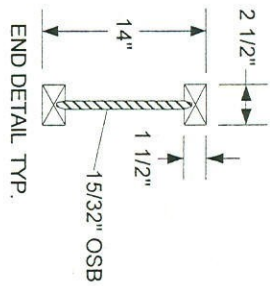

THIS TRUSS IS TRIMMABLE
 UP TO 12" MAY BE FIELD-TRIMMED FROM EACH END OF THIS TRUSS
 SEE TX96284011-001 FOR SPACEJOIST TE ASSEMBLY AND GENERAL NOTES

V2-14 SPACEJOIST METAL WEB
 DILHR APPROVAL #200025-W

1.5X3 TRUSSWAL M20 TRUSS CONNECTOR PLATE TYP.

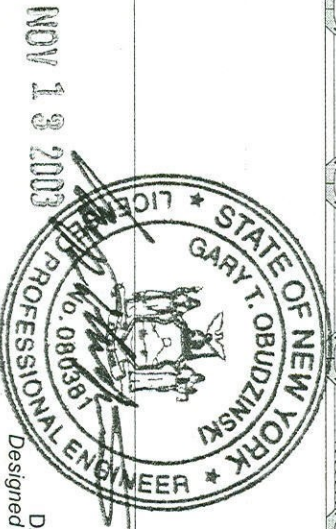
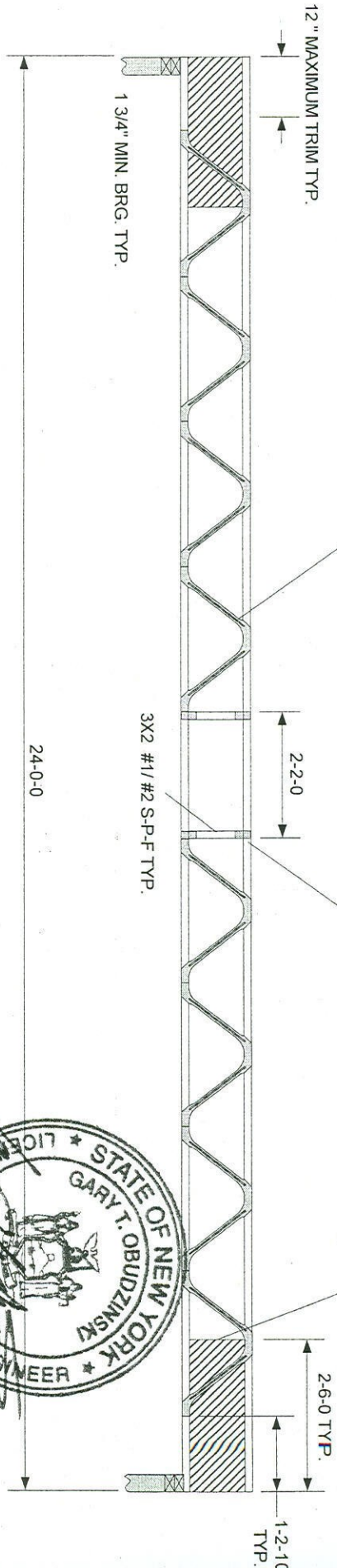

DATE: 01/14/03
 Designed by Trusswal Systems

WARNING Read all notes on this sheet and give a copy of it to the Erecting Contractor.

This design is for an individual building component, not a truss system. It has been based on specifications provided by the component manufacturer and has been completed in accordance with the current versions of TPI and AFPA design standards. No responsibility is assumed for dimensional accuracy. Dimensions are to be verified by the component manufacturer and/or building designer prior to fabrication. The building designer shall ascertain that the loads utilized on this design meet or exceed the loading imposed by the local building code and the particular application. This design assumes that the top chord is laterally braced by the roof or floor sheathing and that the bottom chord is laterally braced by a rigid sheathing material directly attached, unless otherwise noted. Bracing shown is for lateral support of individual component members only. This component shall not be placed in any environment that will cause the moisture content of the wood to exceed 19% and/or cause connector plate corrosion. Fabricate, handle, install, and brace this truss in accordance with the following standards: SPACEJOIST TRUSS FABRICATION MANUAL, by Trusswal Systems; Handling, Installing, and Bracing Metal/Plate Connected Wood Trusses (HIB-91 and HIB-91 Summary Sheet) by TPI. The Truss Plate Institute is located at 583 D'Onofrio Dr., Ste. 200, Madison, WI 53719. The American Forest and Paper Association (AFPA) is located at 1111 19th St. N.W., Ste. 800, Washington, DC 20036.

CHK:	Dsgnr: DL	Customer Name: SpaceJoist TE
TC Live	40 psf	DurFacs: L = 1.00 P = 1.00
TC Dead	See Span Table	Rep Mbr End: 1.15
BC Live	0 psf	Spacing: See Span Table
BC Dead	5 psf	Design Spec: TPI
TOTAL See Span Table		

Trimable End

SpaceJoist

1101 North Great Southwest Parkway
 Arlington, Texas 76011

ALL WEBS ARE 20 GAUGE SPACEJOIST METAL WEBS MANUFACTURED BY TRUSSWAL SYSTEMS CORPORATION.

TOP CHORD 3X2 SPF CAN. 1650F-1.5E
 BOTTOM CHORD 3X2 SPF CAN. 1650F-1.5E
 LUMBER SHEAR ALLOWABLES ARE PER NDS-1997

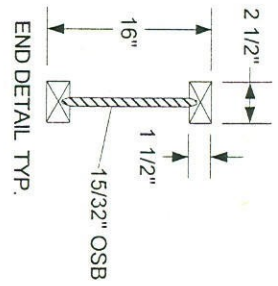

THIS TRUSS IS TRIMMABLE
 UP TO 12" MAY BE FIELD-TRIMMED
 FROM EACH END OF THIS JOIST

SEE TX96284011-001 FOR SPACEJOIST TE
 ASSEMBLY AND GENERAL NOTES

LOADING, PSF	16" SPACEJOIST TE MAXIMUM SPANS			
	DEFLECTION RATIO	SPACING		
40-10-5	L/480	24" O.C.	16" O.C.	12" O.C.
	L/360	21'-9"	24'-2"	25'-8"
40-20-5	L/480	24'-5"	26'-8"	28'-0"
	L/360	18'-3"	22'-0"	28'-0"

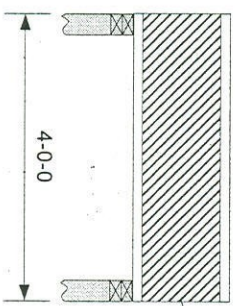

OSB: SEE TX96284011-001
 FOR SPACEJOIST TE
 ASSEMBLY NOTES.

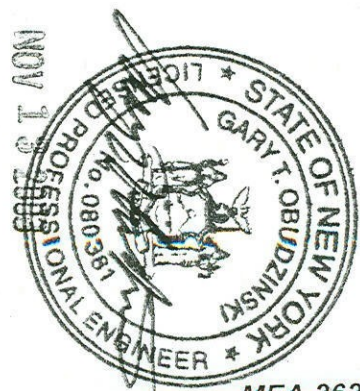

MEA 262-03-E

ALL WEBS ARE 20 GAUGE SPACEJOIST METAL WEBS MANUFACTURED BY TRUSSAL SYSTEMS CORPORATION.

DATE: 01/14/03
 DESIGNED BY TRUSSAL SYSTEMS

WARNING Read all notes on this sheet and give a copy of it to the Erecting Contractor.

This design is for an individual building component, not a truss system. It has been based on specifications provided by the component manufacturer and has been completed in accordance with the current versions of TPI and AFPA design standards. No responsibility is assumed for dimensional accuracy. Dimensions are to be verified by the component manufacturer and/or building designer prior to fabrication. The building designer shall ascertain that the loads utilized on this design meet or exceed the loading imposed by the local building code and the particular application. This design assumes that the top chord is laterally braced by the roof or floor sheathing and that the bottom chord is laterally braced by a rigid sheathing material directly attached, unless otherwise noted. Bracing shown is for lateral support of individual component members only. This component shall not be placed in any environment that will cause the moisture content of the wood to exceed 19% and/or cause connector plate corrosion. Fabricate, handle, install, and brace this truss in accordance with the following standards: SPACEJOIST TRUSS FABRICATION MANUAL, by Trussal Systems; Handling, Installing, and Bracing Metal Plate Connected Wood Trusses (HIB-91 and HIB-91 Summary Sheet) by TPI; The Truss Plate Institute is located at 583 D'Onofrio Dr., Ste. 200, Madison, WI 53719; The American Forest and Paper Association (AFPA) is located at 1111 19th St. N.W., Ste. 800, Washington, DC 20036.

CHK: Dsgnr: DL	Customer Name: SpaceJoist TE
TC Live 40 psf	DurFacs: L = 1.00 P = 1.00
TC Dead See Span Table	Rep Mbr Bnd: 1.15
BC Live 0 psf	Spacing: See Span Table
BC Dead 5 psf	Design Spec: TPI
TOTAL See Span Table	

Trimable End
SpaceJoist™
 1101 North Great Southwest Parkway
 Arlington, Texas 76011

TOP CHORD 3X2 SPF CAN. 1650F-1.8E
 BOTTOM CHORD 3X2 SPF CAN. 1650F-1.8E
 LUMBER SHEAR ALLOWABLES ARE PER NDS-1997

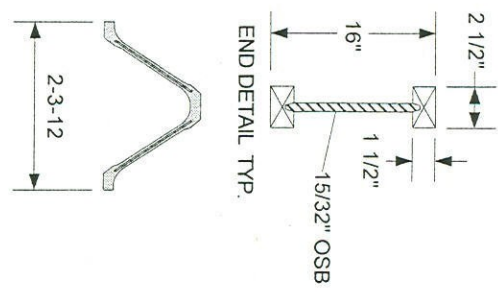

THIS TRUSS IS TRIMMABLE
 UP TO 18" MAY BE FIELD TRIMMED
 FROM EACH END OF THIS TRUSS

LOADING, PSF	16" SPACEJOIST TE MAXIMUM SPANS			
	DEFLECTION RATIO	SPACING		
40-10-5	L/480	24" o.c.	19.2" o.c.	16" o.c.
	L/360	21'-9"	24'-2"	25'-8"
40-20-5	L/480	21'-9"	24'-5"	26'-8"
	L/360	18'-3"	22'-0"	24'-9"
		18'-3"	22'-0"	24'-9"
				28'-0"

SEE TX96284011-001 FOR SPACEJOIST TE ASSEMBLY AND GENERAL NOTES

V2-16 SPACEJOIST METAL WEB
 DILHR APPROVAL #200025-W

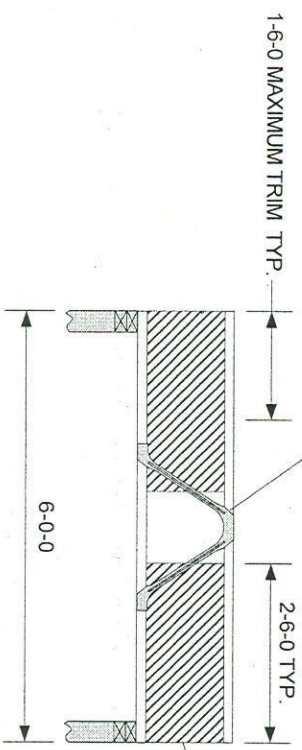

OSB: SEE TX96284011-001 FOR SPACEJOIST TE ASSEMBLY NOTES.

ALL WEBS ARE 20 GAUGE SPACEJOIST METAL WEBS MANUFACTURED BY TRUSSAL SYSTEMS CORPORATION.

WARNING Read all notes on this sheet and give a copy of it to the Erecting Contractor.

Trimmable End

SpaceJoist™



1101 North Great Southwest Parkway
 Arlington, Texas 76011

This design is for an individual building component, not a truss system. It has been based on specifications provided by the component manufacturer and has been completed in accordance with the current versions of TPI and AFPA design standards. No responsibility is assumed for dimensional accuracy. Dimensions are to be verified by the component manufacturer and/or building designer prior to fabrication. The building designer shall ascertain that the loads utilized on this design meet or exceed the loading imposed by the local building code and the particular application. This design assumes that the top chord is laterally braced by the roof or floor sheathing and that the bottom chord is laterally braced by a rigid sheathing material directly attached, unless otherwise noted. Bracing shown is for lateral support of individual component members only. This component shall not be placed in any environment that will cause the moisture content of the wood to exceed 19% and/or cause connector plate corrosion. Fabricate, handle, install, and brace this truss in accordance with the following standards: SPACEJOIST TRUSS FABRICATION MANUAL, by Trussal Systems; Handling, Installing, and Bracing Metal Plate Connected Wood Trusses (HIB-91 and HIB-91 Summary Sheet) by TPI; The Truss Plate Institute is located at 583 D'Onofrio Dr., Ste. 200, Madison, WI 53719; The American Forest and Paper Association (AFPA) is located at 1111 19th St. N.W., Ste. 800, Washington, DC 20036.



MEA 262-03-E

NOV 19 2003

DATE: 01/14/03

DESIGNED BY TRUSSAL SYSTEMS

CHK: Dsgnr: DL
 Customer Name: SpaceJoist TE

TC Live	40 psf	DurFacs: L = 1.00 P = 1.00
TC Dead	See Span Table	Rep Mbr Bnd: 1.15
BC Live	0 psf	Spacing: See Span Table
BC Dead	5 psf	Design Spec: TPI
TOTAL See Span Table		

TOP CHORD 3X2 SPF CAN. 1650F-1.5E
 BOTTOM CHORD 3X2 SPF CAN. 1650F-1.5E
 LUMBER SHEAR ALLOWABLES ARE PER NDS-1997

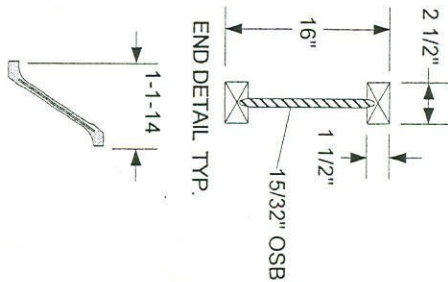

THIS TRUSS IS TRIMMABLE
 UP TO 12" MAY BE FIELD TRIMMED
 FROM EACH END OF THIS TRUSS

SEE TX96284011-001 FOR SPACEJOIST TE
 ASSEMBLY AND GENERAL NOTES

LOADING, PSF	16" SPACEJOIST TE MAXIMUM SPANS			
	DEFLECTION RATIO		SPACING	
40-10-5	L/480	24" O.C.	19.2" O.C.	16" O.C.
	L/360	21'-9"	24'-2"	25'-8"
40-20-5	L/480	18'-3"	22'-0"	24'-9"
	L/360	18'-3"	22'-0"	28'-0"

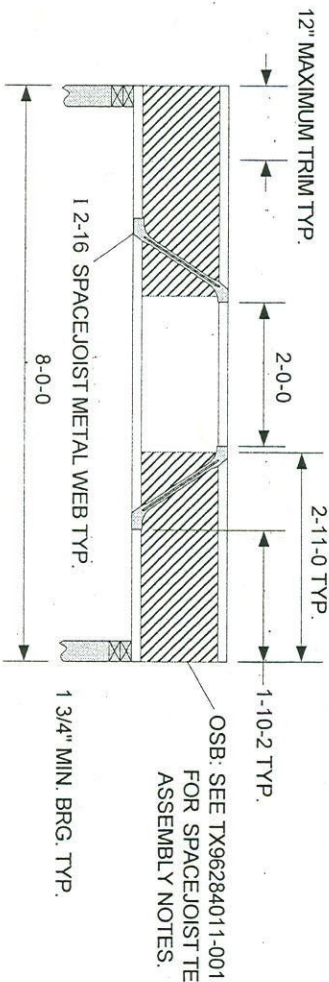

ALL WEBS ARE 20 GAUGE SPACEJOIST METAL WEBS MANUFACTURED BY TRUSSAL SYSTEMS CORPORATION.

WARNING Read all notes on this sheet and give a copy of it to the Erecting Contractor.

This design is for an individual building component, not a truss system. It has been based on specifications provided by the component manufacturer and has been completed in accordance with the current versions of TPI and AFPA design standards. No responsibility is assumed for dimensional accuracy. Dimensions are to be verified by the component manufacturer and/or building designer prior to fabrication. The building designer shall ascertain that the loads utilized on this design meet or exceed the loading imposed by the local building code and the particular application. This design assumes that the top chord is laterally braced by the roof or floor sheathing and that the bottom chord is laterally braced by a rigid sheathing material directly attached, unless otherwise noted. Bracing shown is for lateral support of individual component members only. This component shall not be placed in any environment that will cause the moisture content of the wood to exceed 19% and/or cause connector plate corrosion. Fabricate, handle, install, and brace this truss in accordance with the following standards: SPACEJOIST TRUSS FABRICATION MANUAL by Trussal Systems; Handling, Installing, and Bracing Metal Plate Connected Wood Trusses (HIB-91 and HIB-91 Summary Sheet) by TPI. The Truss Plate Institute is located at 583 Donofrio Dr., Ste. 200, Madison, WI 53719. The American Forest and Paper Association (AFPA) is located at 1111 19th St. N.W., Ste. 800, Washington, DC 20036.

Trimable End

SpaceJoist™

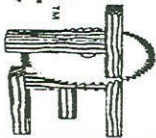

1101 North Great Southwest Parkway
 Arlington, Texas 76011



NOV 19 2003

DATE: 01/14/03

DESIGNED BY TRUSSAL SYSTEMS

Customer Name:
 SpaceJoist TE

CHK: _____
 Dsgnr: DL

TC Live	40 psf
TC Dead	See Span Table
BC Live	0 psf
BC Dead	5 psf
TOTAL See Span Table	

DurFacs: L= 1.00 P= 1.00
 Rep Mbr Bnd: 1.15
 Spacing: See Span Table
 Design Spec: TPI

Job Name: SpaceJoist TE

Truss ID: TE16-10N

Drwg: TX03014021-033

QGNR-1F

TOP CHORD 3X2 SPF CAN, 1650F-1.5E
 BOTTOM CHORD 3X2 SPF CAN, 1650F-1.5E
 LUMBER SHEAR ALLOWABLES ARE PER NDS-1997

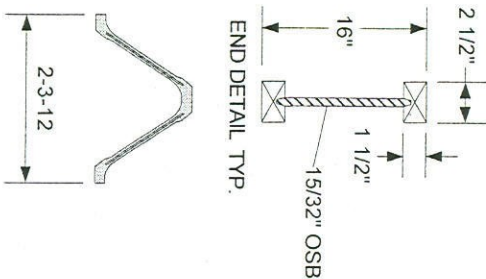

THIS TRUSS IS TRIMMABLE
 UP TO 12" MAY BE FIELD TRIMMED
 FROM EACH END OF THIS TRUSS

SEE TX96284011-001 FOR SPACEJOIST TE
 ASSEMBLY AND GENERAL NOTES

LOADING, PSF	16" SPACEJOIST TE MAXIMUM SPANS		
	DEFLECTION RATIO	SPACING	
40-10-5	L/480	24" o.c.	16" o.c.
	L/360	21'-9"	25'-8"
40-20-5	L/480	24'-5"	28'-0"
	L/360	18'-3"	28'-0"

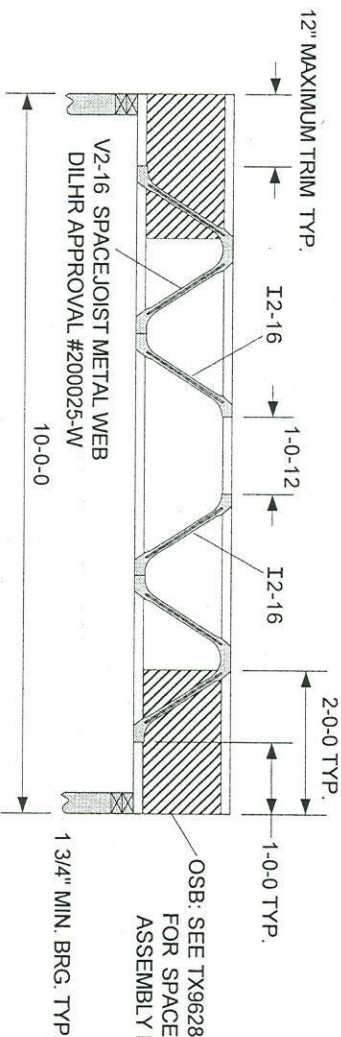

OSB: SEE TX96284011-001
 FOR SPACEJOIST TE
 ASSEMBLY NOTES.

ALL WEBS ARE 20 GAUGE SPACEJOIST METAL WEBS MANUFACTURED BY TRUSSAL SYSTEMS CORPORATION.

WARNING Read all notes on this sheet and give a copy of it to the Erecting Contractor.

This design is for an individual building component, not a truss system. It has been based on specifications provided by the component manufacturer and has been completed in accordance with the current versions of TPI and AEP/A design standards. No responsibility is assumed for dimensional accuracy. Dimensions are to be verified by the component manufacturer and/or building designer prior to fabrication. The building designer shall ascertain that the loads utilized on this design meet or exceed the loading imposed by the local building code and the particular application. This design assumes that the top chord is laterally braced by the roof or floor sheathing and that the bottom chord is laterally braced by a rigid sheathing material directly attached, unless otherwise noted. Bracing shown is for lateral support of individual component members only. This component shall not be placed in any environment that will cause the moisture content of the wood to exceed 19% and/or cause connector plate corrosion. Fabricate, handle, install, and brace this truss in accordance with the following standards: SPACEJOIST TRUSS FABRICATION MANUAL, by Trussal Systems; Handling, Installing, and Bracing Metal Plate Connected Wood Trusses (HIB-91 and HIB-91 Summary Sheet) by TPI. The Truss Plate Institute is located at 583 D'Onofrio Dr., Ste. 200, Madison, WI 53719. The American Forest and Paper Association (AFPA) is located at 1111 19th St. N.W., Ste. 800, Washington, DC 20036.

CHK:		Customer Name:	SpaceJoist TE
Dsgnr: DL			
TC Live	40 psf	DurFacs: L= 1.00 P= 1.00	
TC Dead	See Span Table	Rep Mbr Bnd: 1.15	
BC Live	0 psf	Spacing: See Span Table	
BC Dead	5 psf	Design Spec: TPI	
TOTAL	See Span Table		

DATE: 01/14/03

DESIGNED BY TRUSSAL SYSTEMS

NOV 13 2003



MEA 262-03-E

Trimable End
SpaceJoist™
 1101 North Great Southwest Parkway
 Arlington, Texas 76011

TOP CHORD 3X2 SPF CAN. 1650F-1.5E
 BOTTOM CHORD 3X2 SPF CAN. 1650F-1.5E
 LUMBER SHEAR ALLOWABLES ARE PER NDS-1997

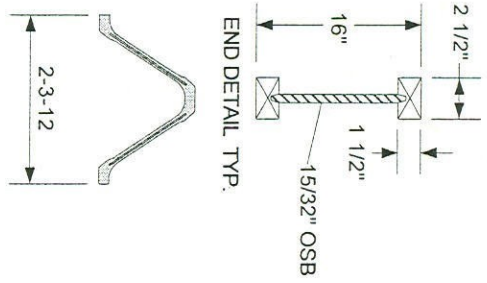

THIS TRUSS IS TRIMMABLE
 UP TO 12" MAY BE FIELD TRIMMED
 FROM EACH END OF THIS TRUSS

LOADING, PSF	16" SPACEJOIST TE MAXIMUM SPANS			
	DEFLECTION RATIO	SPACING		
40-10-5	L/480	24" O.C.	19.2" O.C.	16" O.C.
	L/360	21'-9"	24'-2"	25'-8"
40-20-5	L/480	21'-9"	24'-5"	26'-8"
	L/360	18'-3"	22'-0"	24'-9"
		18'-3"	22'-0"	24'-9"
				28'-0"

SEE TX96284011-001 FOR SPACEJOIST TE ASSEMBLY AND GENERAL NOTES

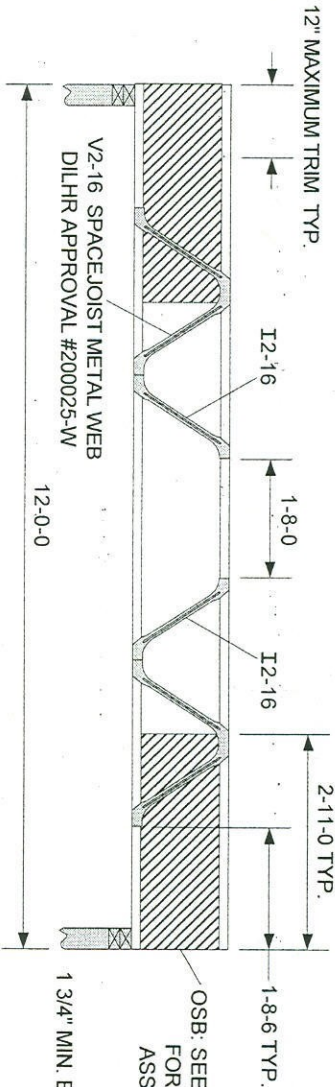

OSB: SEE TX96284011-001 FOR SPACEJOIST ASSEMBLY NOTES

ALL WEBS ARE 20 GAUGE SPACEJOIST METAL WEBS MANUFACTURED BY TRUSSAL SYSTEMS CORPORATION.

WARNING Read all notes on this sheet and give a copy of it to the Erecting Contractor.

This design is for an individual building component, not a truss system. It has been based on specifications provided by the component manufacturer and has been completed in accordance with the current versions of TPI and AFPA design standards. No responsibility is assumed for dimensional accuracy. Dimensions are to be verified by the component manufacturer and/or building designer prior to fabrication. The building designer shall ascertain that the loads utilized on this design meet or exceed the loading imposed by the local building code and the particular application. This design assumes that the top chord is laterally braced by the roof or floor sheathing and that the bottom chord is laterally braced by a rigid sheathing material directly attached, unless otherwise noted. Bracing shown is for lateral support of individual component members only. This component shall not be placed in any environment that will cause the moisture content of the wood to exceed 19% and/or cause connector plate corrosion. Fabricate, handle, install, and brace this truss in accordance with the following standards: SPACEJOIST TRUSS FABRICATION MANUAL by Trussal Systems; Handling, Installing, and Bracing Metal Plate Connected Wood Trusses (HIB-91 and HIB-91 Summary Sheet) by TPI. The Truss Plate Institute is located at 583 Donofrio Dr., Ste. 200, Madison, WI 53719. The American Forest and Paper Association (AFPA) is located at 1111 19th St. N.W., Ste. 800, Washington, DC 20036.

CHK:	Customer Name:	SpaceJoist TE
Dsgnr: DL		
TC Live	DurFacs: L= 1.00 P= 1.00	
TC Dead	Rep Mbr Bnd: 1.15	
BC Live	Spacing: See Span Table	
BC Dead	Design Spec: TPI	
TOTAL	See Span Table	

Trimtable End
SpaceJoist™
 1101 North Great Southwest Parkway
 Arlington, Texas 76011

NOV 13 2003
 DATE: 01/14/03
 DESIGNED BY TRUSSAL SYSTEMS
 STATE OF NEW YORK
 GARY T. OBUZZINSKI
 LICENSED PROFESSIONAL ENGINEER
 No. 088057
 MEA 262-03-E

TOP CHORD 3X2 SPF CAN. 2100F-1.8E
 BOTTOM CHORD 3X2 SPF CAN. 2100F-1.8E
 LUMBER SHEAR ALLOWABLES ARE PER NDS-1997

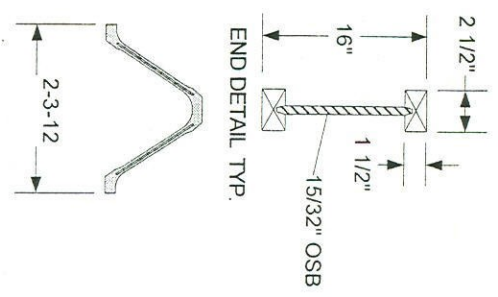

THIS TRUSS IS TRIMMABLE
 UP TO 12" MAY BE FIELD TRIMMED
 FROM EACH END OF THIS TRUSS

SEE TX96284011-001 FOR SPACEJOIST TE
 ASSEMBLY AND GENERAL NOTES

LOADING, PSF	16" SPACEJOIST TE MAXIMUM SPANS			
	SPACING			
DEFLECTION RATIO	24" o.c.	19.2" o.c.	16" o.c.	12" o.c.
40-10-5	L/480	21'-9"	24'-2"	25'-8"
	L/360	21'-9"	24'-5"	26'-8"
40-20-5	L/480	18'-3"	22'-0"	24'-9"
	L/360	18'-3"	22'-0"	28'-0"

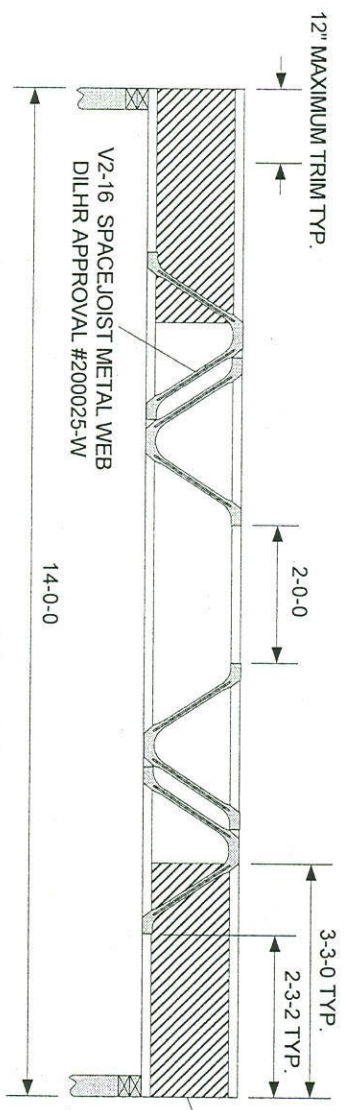

OSB: SEE TX96284011-001 FOR SPACEJOIST TE ASSEMBLY NOTES.

ALL WEBS ARE 20 GAUGE SPACEJOIST METAL WEBS MANUFACTURED BY TRUSWAL SYSTEMS CORPORATION.

WARNING Read all notes on this sheet and give a copy of it to the Erecting Contractor.

This design is for an individual building component, not a truss system. It has been based on specifications provided by the component manufacturer and has been completed in accordance with the current versions of TPI and AFPA design standards. No responsibility is assumed for dimensional accuracy. Dimensions are to be verified by the component manufacturer and/or building designer prior to fabrication. The building designer shall ascertain that the loads utilized on this design meet or exceed the loading imposed by the local building code and the particular application. This design assumes that the top chord is laterally braced by the roof or floor sheathing and that the bottom chord is laterally braced by a rigid sheathing material directly attached, unless otherwise noted. Bracing shown is for lateral support of individual component members only. This component shall not be placed in any environment that will cause the moisture content of the wood to exceed 19% and/or cause connector plate corrosion. Fabricate, handle, install, and brace this truss in accordance with the following standards: SPACEJOIST TRUSS FABRICATION MANUAL, by Trussal Systems; Handling, Installing, and Bracing Metal Plate Connected Wood Trusses (HIB-91 and HIB-91 Summary Sheet) by TPI. The Truss Plate Institute is located at 583 D'Onofrio Dr., Ste. 200, Madison, WI 53719. The American Forest and Paper Association (AFPA) is located at 1111 19th St. N.W., Ste. 800, Washington, DC 20036.

NOV 19 2003

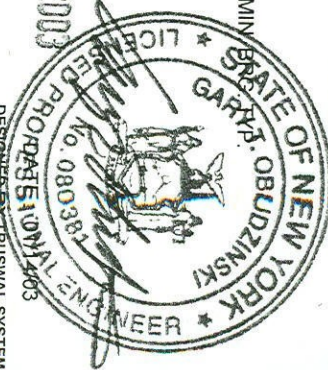

Chk: _____
 Dsgnr: DL

TC Live	40 psf	DurFacs: L = 1.00 P = 1.00
TC Dead	See Span Table	Rep Mbr Bnd: 1.15
BC Live	0 psf	Spacing: See Span Table
BC Dead	5 psf	Design Spec: TPI
TOTAL See Span Table		



1101 North Great Southwest Parkway
 Arlington, Texas 76011

Job Name: SpaceJoist TE

Truss ID: TE16-16N

Dwg: TX03014021-036

QG NR-1F

TOP CHORD 3X2 SPF CAN. 2100F-1.8E
 BOTTOM CHORD 3X2 SPF CAN. 2100F-1.8E
 LUMBER SHEAR ALLOWABLES ARE PER NDS-1997

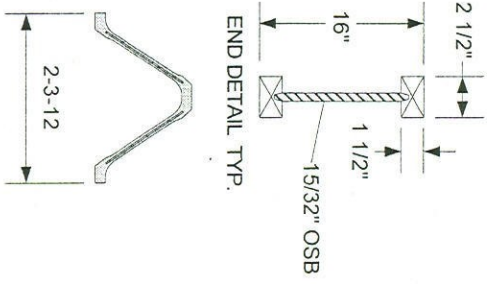

THIS TRUSS IS TRIMMABLE
 UP TO 12" MAY BE FIELD TRIMMED
 FROM EACH END OF THIS TRUSS

SEE TX96284011-001 FOR SPACEJOIST TE
 ASSEMBLY AND GENERAL NOTES

LOADING, PSF	16" SPACEJOIST TE MAXIMUM SPANS		
	DEFLECTION RATIO	SPACING	
40-10-5	L/480	24" o.c.	16" o.c.
	L/360	21'-9"	25'-8"
40-20-5	L/480	24'-5"	26'-8"
	L/360	18'-3"	24'-9"

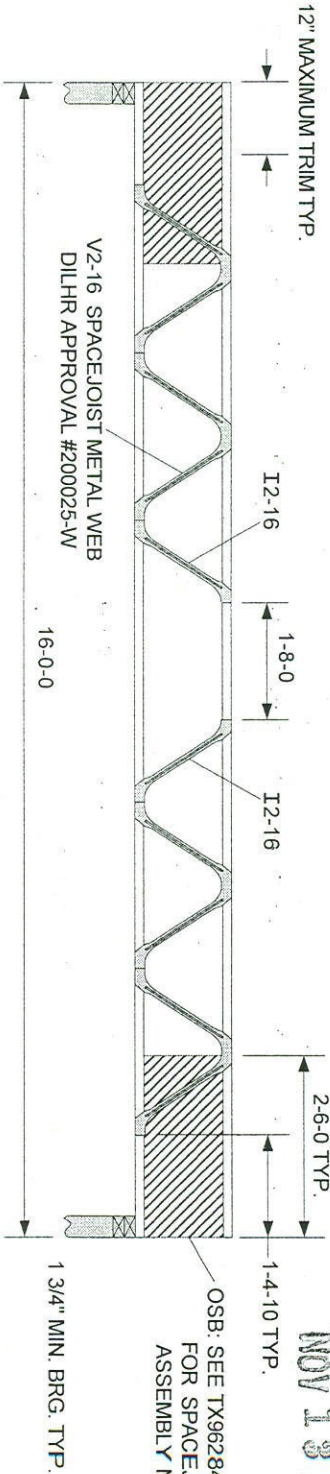

NOV 13 2003

OSB: SEE TX96284011-001
 FOR SPACEJOIST TE
 ASSEMBLY NOTES.

ALL WEBS ARE 20 GAUGE SPACEJOIST METAL WEBS MANUFACTURED BY TRUSWAL SYSTEMS CORPORATION.

WARNING Read all notes on this sheet and give a copy of it to the Erecting Contractor.

Trimable End

SpaceJoist™

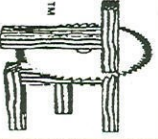

1101 North Great Southwest Parkway
 Arlington, Texas 76011

This design is for an individual building component, not a truss system. It has been based on specifications provided by the component manufacturer and has been completed in accordance with the current versions of TPI and AFPA design standards. No responsibility is assumed for dimensional accuracy. Dimensions are to be verified by the component manufacturer and/or building designer prior to fabrication. The building designer shall ascertain that the loads utilized on this design meet or exceed the loading imposed by the local building code and the particular application. This design assumes that the top chord is laterally braced by the roof or floor sheathing and that the bottom chord is laterally braced by a rigid sheathing material directly attached, unless otherwise noted. Bracing shown is for lateral support of individual component members only. This component shall not be placed in any environment that will cause the moisture content of the wood to exceed 19% and/or cause connector plate corrosion. Fabricate, handle, install, and brace this truss in accordance with the following standards: SPACEJOIST TRUSS FABRICATION MANUAL, by Truswal Systems; Handling, Installing, and Bracing Metal Plate Connected Wood Trusses (HIB-91 and HIB-91 Summary Sheet) by TPI; The Truss Plate Institute is located at 583 D'Onofrio Dr., Ste. 200, Madison, WI 53719; The American Forest and Paper Association (AFPA) is located at 1111 19th St. N.W., Ste. 800, Washington, DC 20036.

CHK: Dsgnr: DL	Customer Name: SpaceJoist TE
TC Live 40 psf	DurFacs: L= 1.00 P= 1.00
TC Dead See Span Table	Rep Mbr End: 1.15
BC Live 0 psf	Spacing: See Span Table
BC Dead 5 psf	Design Spec: TPI
TOTAL See Span Table	

DATE: 01/14/03

DESIGNED BY TRUSWAL SYSTEMS

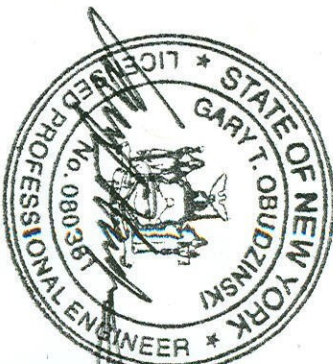

Job Name: SpaceJoist TE

Truss ID: TE16-18N

Drwg: TX03014021-037

QGNR-1F

TOP CHORD 3X2 SPF CAN. 2100F-1.8E
 BOTTOM CHORD 3X2 SPF CAN. 2100F-1.8E
 LUMBER SHEAR ALLOWABLES ARE PER NDS-1997

LOADING, PSF	16" SPACEJOIST TE MAXIMUM SPANS			
	DEFLECTION RATIO	SPACING		
40-10-5	L/480	24" O.C.	19.2" O.C.	16" O.C.
	L/360	21'-9"	24'-2"	25'-8"
	L/480	21'-9"	24'-5"	26'-8"
40-20-5	L/480	18'-3"	22'-0"	24'-9"
	L/360	18'-3"	22'-0"	28'-0"

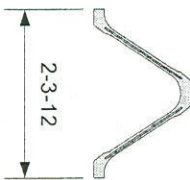
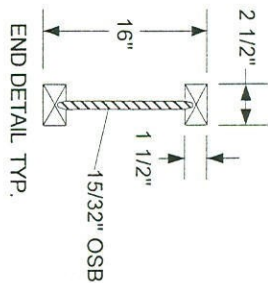

THIS TRUSS IS TRIMMABLE
 UP TO 12" MAY BE FIELD TRIMMED
 FROM EACH END OF THIS TRUSS

SEE TX96284011-001 FOR SPACEJOIST TE
 ASSEMBLY AND GENERAL NOTES

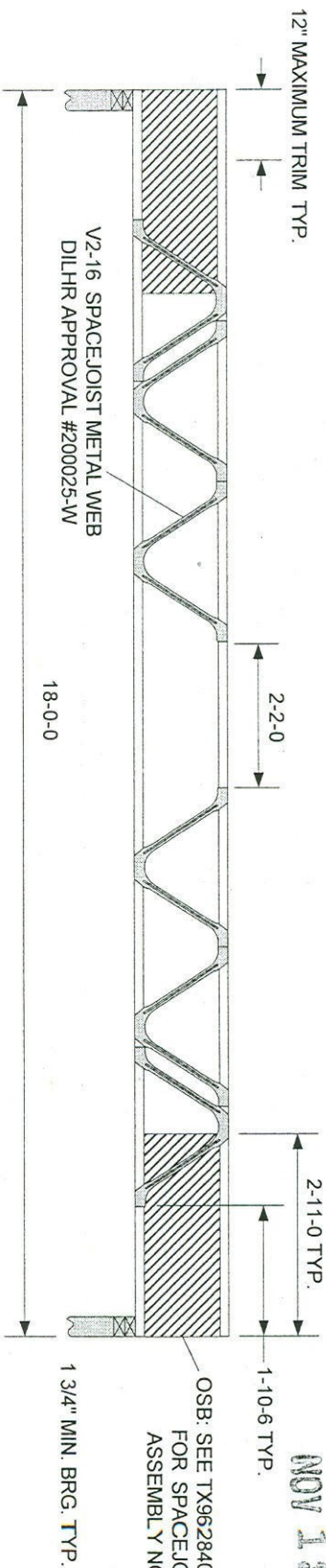

NOV 13 2003

ALL WEBS ARE 20 GAUGE SPACEJOIST METAL WEBS MANUFACTURED BY TRUSSAL SYSTEMS CORPORATION.

WARNING Read all notes on this sheet and give a copy of it to the Erecting Contractor.

This design is for an individual building component, not a truss system. It has been based on specifications provided by the component manufacturer and has been completed in accordance with the current versions of TPI and AFPA design standards. No responsibility is assumed for dimensional accuracy. Dimensions are to be verified by the component manufacturer and/or building designer prior to fabrication. The building designer shall ascertain that the loads utilized on this design meet or exceed the loading imposed by the local building code and the particular application. This design assumes that the top chord is laterally braced by the roof or floor sheathing and that the bottom chord is laterally braced by a rigid sheathing material directly attached, unless otherwise noted. Bracing shown is for lateral support of individual component members only. This component shall not be placed in any environment that will cause the moisture content of the wood to exceed 19% and/or cause connector plate corrosion. Fabricate, handle, install, and brace this truss in accordance with the following standards: SPACEJOIST TRUSS FABRICATION MANUAL, by Trussal Systems; Handling, Installing, and Bracing Metal Plate Connected Wood Trusses (HIB-91 and HIB-91 Summary Sheet) by TPI. The Truss Plate Institute is located at 583 D'Onofrio Dr., Ste. 200, Madison, WI 53719. The American Forest and Paper Association (AFPA) is located at 1111 19th St. N.W., Ste. 800, Washington, DC 20036.

Trimable End

SpaceJoist™

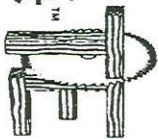

1101 North Great Southwest Parkway
 Arlington, Texas 76011

Chk:		Customer Name:	SpaceJoist TE
Dsgnr: DL			
TC Live	40 psf	DuFacs: L= 1.00 P= 1.00	
TC Dead	See Span Table	Rep Mbr Bnd: 1.15	
BC Live	0 psf	Spacing: See Span Table	
BC Dead	5 psf	Design Spec: TPI	
TOTAL	See Span Table		

DESIGNED BY TRUSSAL SYSTEMS

DATE: 01/14/03

MEA 262-03-E

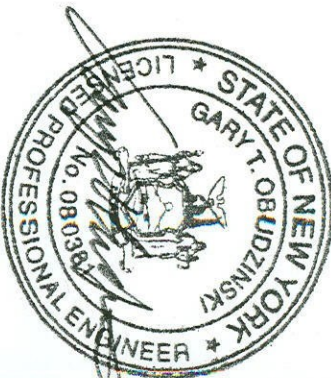

Job Name: SpaceJoist TE

Truss ID: TE16-20N

Drwg: TX03014021-038

QGNR-1F

TOP CHORD 3X2 SPF CAN 2100F-1.8E
 BOTTOM CHORD 3X2 SPF CAN 2100F-1.8E
 LUMBER SHEAR ALLOWABLES ARE PER NDS-1997

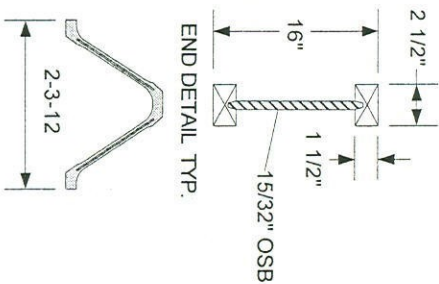

THIS TRUSS IS TRIMMABLE
 UP TO 12" MAY BE FIELD TRIMMED
 FROM EACH END OF THIS TRUSS

LOADING, PSF	16" SPACEJOIST TE MAXIMUM SPANS			
	DEFLECTION RATIO	SPACING		
40-10-5	L/480	24" o.c.	19.2" o.c.	16" o.c.
	L/360	21'-9"	24'-2"	25'-8"
	L/480	21'-9"	24'-5"	26'-8"
40-20-5	L/480	18'-3"	22'-0"	24'-9"
	L/360	18'-3"	22'-0"	28'-0"

SEE TX96284011-001 FOR SPACEJOIST TE ASSEMBLY AND GENERAL NOTES

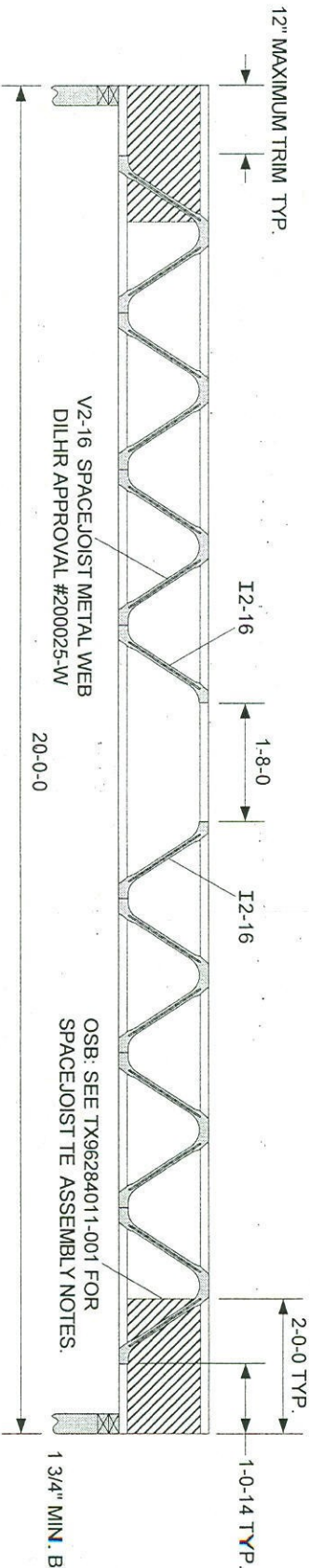

ALL WEBS ARE 20 GAUGE SPACEJOIST METAL WEBS MANUFACTURED BY TRUSWAL SYSTEMS CORPORATION.

WARNING Read all notes on this sheet and give a copy of it to the Erecting Contractor.

This design is for an individual building component, not a truss system. It has been based on specifications provided by the component manufacturer and has been completed in accordance with the current versions of TP1 and AFPA design standards. No responsibility is assumed for dimensional accuracy. Dimensions are to be verified by the component manufacturer and/or building designer prior to fabrication. The building designer shall ascertain that the loads utilized on this design meet or exceed the loading imposed by the local building code and the particular application. This design assumes that the top chord is laterally braced by the roof or floor sheathing and that the bottom chord is laterally braced by a rigid sheathing material directly attached, unless otherwise noted. Bracing shown is for lateral support of individual component members only. This component shall not be placed in any environment that will cause the moisture content of the wood to exceed 19% and/or cause connector plate corrosion. Fabricate, handle, install, and brace this truss in accordance with the following standards: SPACEJOIST TRUSS FABRICATION MANUAL, by Trussal Systems; Handling, Installing, and Bracing Metal Plate Connected Wood Trusses (HIB-91 and HIB-91 Summary Sheet) by TP1. The Truss Plate Institute is located at 583 D'Onofrio Dr., Ste. 200, Madison, WI 53719. The American Forest and Paper Association (AFPA) is located at 1111 19th St. N.W., Ste. 800, Washington, DC 20036.

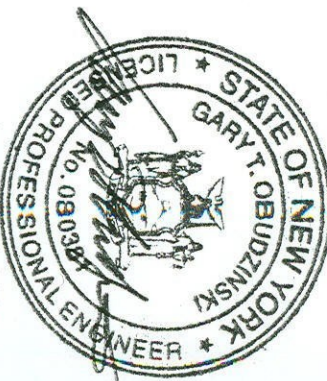

CHK:	Dsgnr: DL	Customer Name: SpaceJoist TE
TC Live	40 psf	DurFacs: L= 1.00 P= 1.00
TC Dead	See Span Table	Rep Mbr Bnd: 1.15
BC Live	0 psf	Spacing: See Span Table
BC Dead	5 psf	Design Spec: TPI
TOTAL See Span Table		

Trimable End

SpaceJoist™

1101 North Great Southwest Parkway
 Arlington, Texas 76011

TOP CHORD 3X2 SPF CAN. 2100F-1.8E
 BOTTOM CHORD 3X2 SPF CAN. 2100F-1.8E
 LUMBER SHEAR ALLOWABLES ARE PER NDS-1997

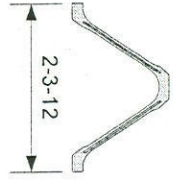
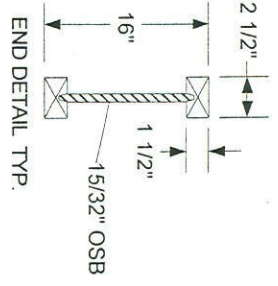

THIS TRUSS IS TRIMMABLE
 UP TO 12" MAY BE FIELD-TRIMMED FROM
 EACH END OF THIS TRUSS.

SEE TX96284011-001 FOR SPACEJOIST TE
 ASSEMBLY AND GENERAL NOTES

LOADING, PSF	16" SPACEJOIST TE MAXIMUM SPANS			
	DEFLECTION RATIO			
40-10-5	L/480	24" O.C.	19.2" O.C.	16" O.C.
	L/360	21'-9"	24'-2"	25'-8"
	L/480	21'-9"	24'-5"	26'-8"
40-20-5	L/480	18'-3"	22'-0"	24'-9"
	L/360	18'-3"	22'-0"	28'-0"

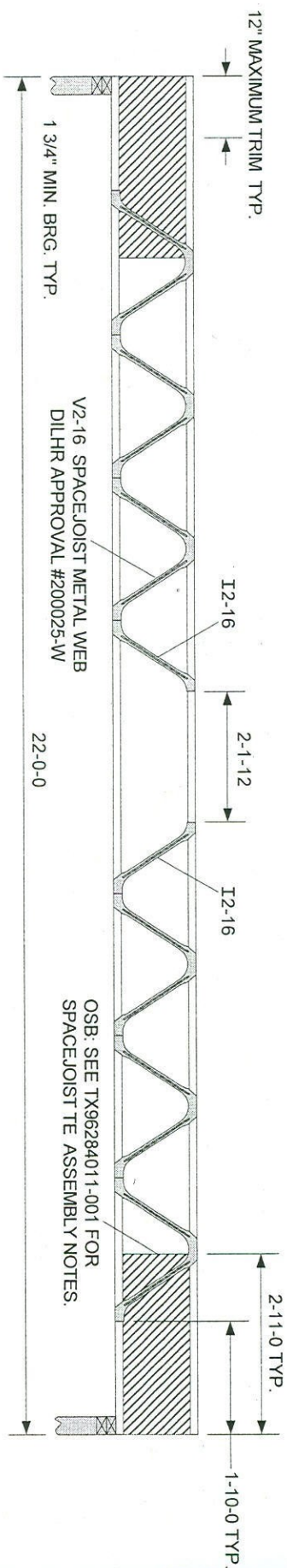

ALL WEBS ARE 20 GAUGE SPACEJOIST METAL WEBS MANUFACTURED BY TRUSVAL SYSTEMS CORPORATION.

WARNING Read all notes on this sheet and give a copy of it to the Erecting Contractor.

This design is for an individual building component, not a truss system. It has been based on specifications provided by the component manufacturer and has been completed in accordance with the current versions of TPI and AFPA design standards. No responsibility is assumed for dimensional accuracy. Dimensions are to be verified by the component manufacturer and/or building designer prior to fabrication. The building designer shall ascertain that the loads utilized on this design meet or exceed the loading imposed by the local building code and the particular application. This design assumes that the top chord is laterally braced by the roof or floor sheathing and that the bottom chord is laterally braced by a rigid sheathing material directly attached, unless otherwise noted. Bracing shown is for lateral support of individual component members only. This component shall not be placed in any environment that will cause the moisture content of the wood to exceed 19% and/or cause connector plate corrosion. Fabricate, handle, install, and brace this truss in accordance with the following standards: SPACEJOIST TRUSS FABRICATION MANUAL, by Trusval Systems; Handling, Installing, and Bracing Metal Plate Connected Wood Trusses (HB-91 and HB-91 Summary Sheet) by TPI; The Truss Plate Institute is located at 583 D'Onofrio Dr., Ste. 200, Madison, WI 53719. The American Forest and Paper Association (AFPA) is located at 1114 19th St. N.W., Ste. 800, Washington, DC 20036.

CHK: Dsgnr: DL	Customer Name: SpaceJoist TE
TC Live 40 psf	DurFacs: L=1.00 P=1.00
TC Dead See Span Table	Rep Mbr End: 1.15
BC Live 0 psf	Spacing: See Span Table
BC Dead 5 psf	Design Spec: TPI
TOTAL See Span Table	

Trimable End

SpaceJoist
 1101 North Great Southwest Parkway
 Arlington, Texas 76011



NOV 13 2003

DATE: 01/14/03
 DESIGNED BY TRUSVAL SYS

TOP CHORD 3X2 SPF CAN. 2100F-1.8E
 BOTTOM CHORD 3X2 SPF CAN. 2100F-1.8E
 LUMBER SHEAR ALLOWABLES ARE PER NDS-1997

LOADING, PSF	16" SPACEJOIST TE MAXIMUM SPANS			
	DEFLECTION RATIO	SPACING		
40-10-5	L/480	24" O.C.	19.2" O.C.	16" O.C.
	L/360	21'-9"	24'-2"	25'-8"
40-20-5	L/480	18'-3"	22'-0"	24'-9"
	L/360	18'-3"	22'-0"	28'-0"

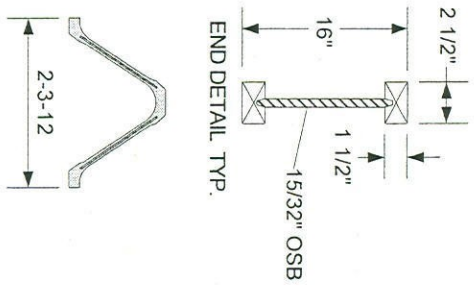

THIS TRUSS IS TRIMMABLE
 UP TO 12" MAY BE FIELD TRIMMED
 FROM EACH END OF THIS TRUSS

SEE TX96284011-001 FOR SPACEJOIST TE ASSEMBLY AND GENERAL NOTES



NOV 13 2003

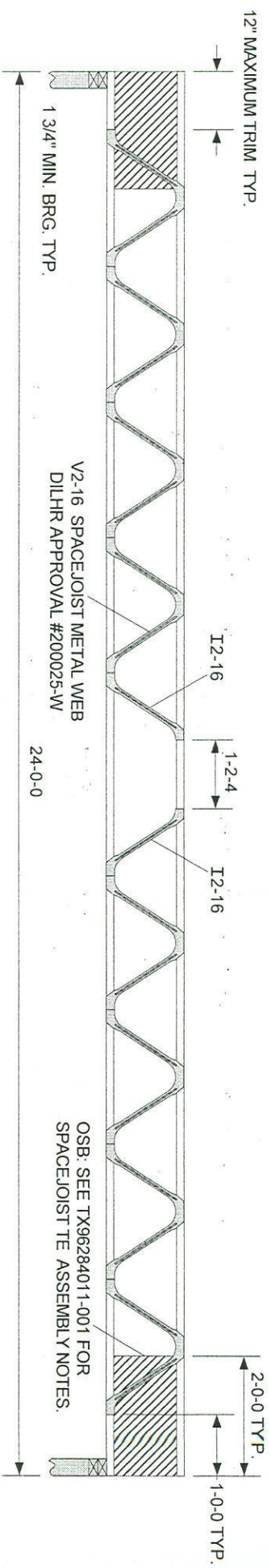

ALL WEBS ARE 20 GAUGE SPACEJOIST METAL WEBS MANUFACTURED BY TRUSSAL SYSTEMS CORPORATION.

WARNING Read all notes on this sheet and give a copy of it to the Erecting Contractor.

This design is for an individual building component, not a truss system. It has been based on specifications provided by the component manufacturer and has been completed in accordance with the current versions of TPI and AFPA design standards. No responsibility is assumed for dimensional accuracy. Dimensions are to be verified by the component manufacturer and/or building designer prior to fabrication. The building designer shall ascertain that the loads utilized on this design meet or exceed the loading imposed by the local building code and the particular application. This design assumes that the top chord is laterally braced by the roof or floor sheathing and that the bottom chord is laterally braced by a rigid sheathing material directly attached, unless otherwise noted. Bracing shown is for lateral support of individual component members only. This component shall not be placed in any environment that will cause the moisture content of the wood to exceed 19% and/or cause connector plate corrosion. Fabricate, handle, install, and brace this truss in accordance with the following standards: SPACEJOIST TRUSS FABRICATION MANUAL, by Trussal Systems; Handling, Installing, and Bracing Metal Plate Connected Wood Trusses (HIB 91 and HIB 91 Summary Sheet) by TPI; The Truss Plate Institute is located at 583 D'Onofrio Dr., Ste. 200, Madison, WI 53719; The American Forest and Paper Association (AFPA) is located at 1111 19th St. N.W., Ste. 800, Washington, DC 20036.

CHK: Degr.: DL	Customer Name: SpaceJoist TE
TC Live 40 psf	DurFacs: L = 1.00 P = 1.00
TC Dead See Span Table	Rep Mbr Bnd: 1.15
BC Live 0 psf	Spacing: See Span Table
BC Dead 5 psf	Design Spec: TPI
TOTAL See Span Table	

DATE: 01/14/03
 DESIGNED BY TRUSSAL SYSTEMS

Trimable End

SpaceJoist

1101 North Great Southwest Parkway
 Arlington, Texas 76011

TOP CHORD 3X2 SPF CAN. 2100F-1.8E
 BOTTOM CHORD 3X2 SPF CAN. 2100F-1.8E
 LUMBER SHEAR ALLOWABLES ARE PER NDS-1997

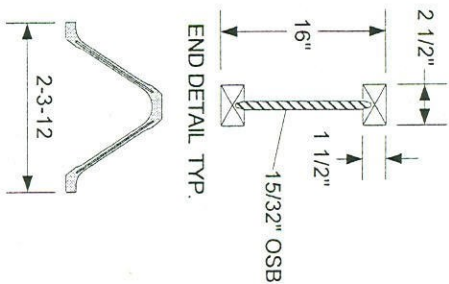

THIS TRUSS IS TRIMMABLE
 UP TO 12" MAY BE FIELD TRIMMED
 FROM EACH END OF THIS TRUSS

SEE TX96284011-001 FOR SPACEJOIST TE
 ASSEMBLY AND GENERAL NOTES

		16" SPACEJOIST TE MAXIMUM SPANS			
LOADING, PSF	DEFLECTION RATIO	SPACING			
		40-10-5	L/480	24" o.c.	16" o.c.
40-20-5	L/360	21'-9"	24'-2"	25'-8"	28'-0"
	L/480	21'-9"	24'-5"	26'-8"	28'-0"
	L/360	18'-3"	22'-0"	24'-9"	28'-0"

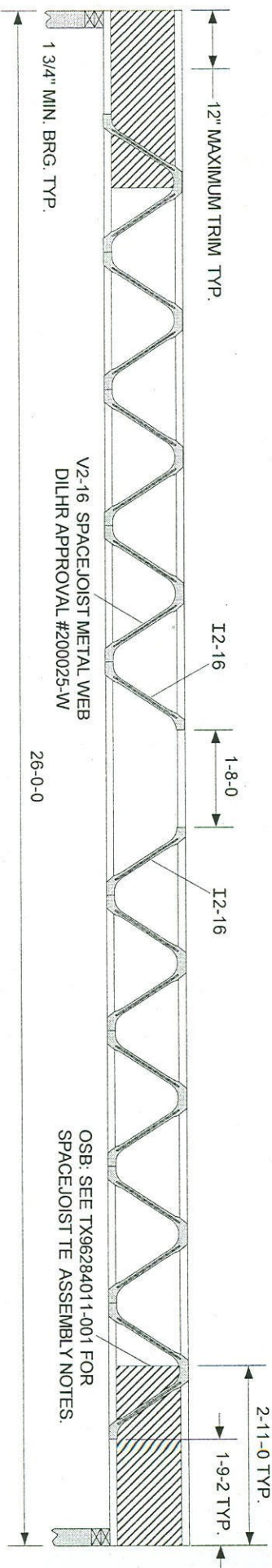

V2-16 SPACEJOIST METAL WEB
 DILHR APPROVAL #200025-W

OSB: SEE TX96284011-001 FOR
 SPACEJOIST TE ASSEMBLY NOTES.

ALL WEBS ARE 20 GAUGE SPACEJOIST METAL WEBS MANUFACTURED BY TRUSVAL SYSTEMS CORPORATION.

WARNING Read all notes on this sheet and give a copy of it to the Erecting Contractor.

This design is for an individual building component, not a truss system. It has been based on specifications provided by the component manufacturer and has been completed in accordance with the current versions of TPI and AFPA design standards. No responsibility is assumed for dimensional accuracy. Dimensions are to be verified by the component manufacturer and/or building designer prior to fabrication. The building designer shall ascertain that the loads utilized on this design meet or exceed the loading imposed by the local building code and the particular application. This design assumes that the top chord is laterally braced by the roof or floor sheathing and that the bottom chord is laterally braced by a rigid sheathing material directly attached, unless otherwise noted. Bracing shown is for lateral support of individual component members only. This component shall not be placed in any environment that will cause the moisture content of the wood to exceed 19% and/or cause connector plate corrosion. Fabricate, handle, install, and brace this truss in accordance with the following standards: SPACEJOIST TRUSS FABRICATION MANUAL, by Trusval Systems; Handling, Installing, and Bracing Metal Plate Connected Wood Trusses (HIB-91 and HIB-91 Summary Sheet) by TPI. The Truss Plate Institute is located at 583 D'Onofrio Dr., Ste. 200, Madison, WI 53719. The American Forest and Paper Association (AFPA) is located at 1111 19th St. N.W., Ste. 800, Washington, DC 20036.

CHK: Dsgnr: DL

Customer Name: SpaceJoist TE

DATE: 01/14/03

DESIGNED BY TRUSVAL SYSTEMS

Trimmiabie End

SpaceJoist™

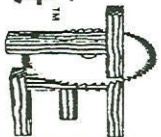

1101 North Great Southwest Parkway
 Arlington, Texas 76011

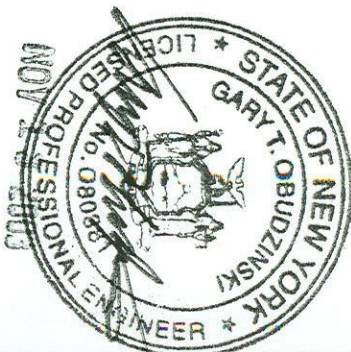

TC Live	40 psf	DurFacs: L= 1.00 P= 1.00
TC Dead	See Span Table	Rep Mbr Bnd: 1.15
BC Live	0 psf	Spacing: See Span Table
BC Dead	5 psf	Design Spec: TPI
TOTAL See Span Table		

TOP CHORD 3X2 SPF CAN. 2100F-1.8E
 BOTTOM CHORD 3X2 SPF CAN. 2100F-1.8E
 LUMBER SHEAR ALLOWABLES ARE PER NDS-1997

LOADING, PSF	16" SPACEJOIST TE MAXIMUM SPANS			
	DEFLECTION RATIO	SPACING		
40-10-5	L/480	24" o.c.	19.2" o.c.	16" o.c.
	L/360	21'-9"	24'-5"	25'-8"
40-20-5	L/480	18'-3"	22'-0"	24'-9"
	L/360	18'-3"	22'-0"	28'-0"

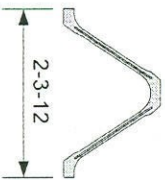
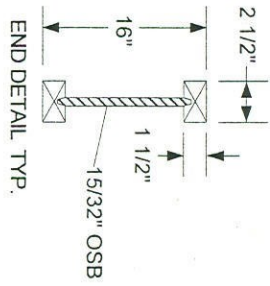

THIS TRUSS IS TRIMMABLE
 UP TO 12" MAY BE FIELD TRIMMED
 FROM EACH END OF THIS TRUSS

SEE TX96284011-001 FOR SPACEJOIST TE ASSEMBLY AND GENERAL NOTES

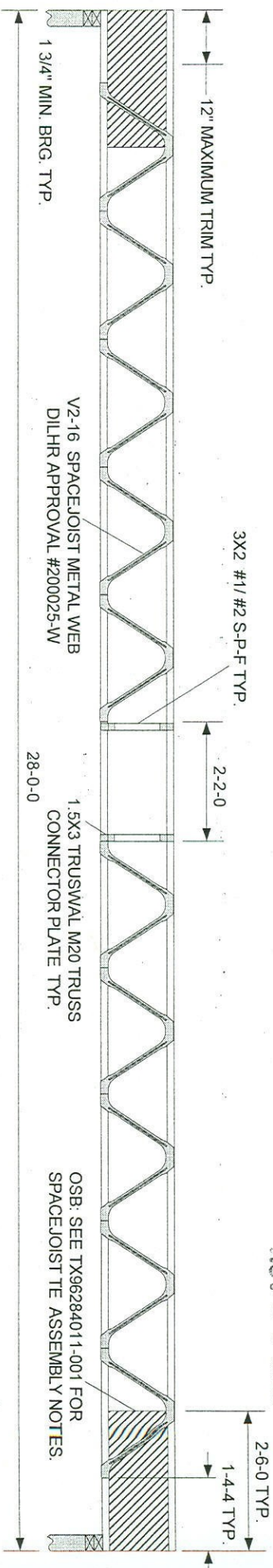
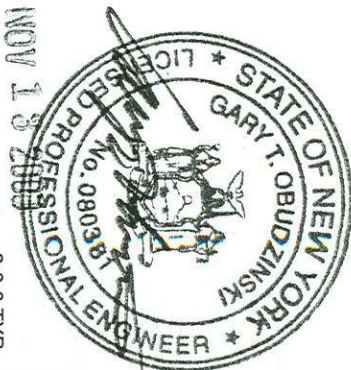

ALL WEBS ARE 20 GAUGE SPACEJOIST METAL WEBS MANUFACTURED BY TRUSSWAL SYSTEMS CORPORATION.

WARNING Read all notes on this sheet and give a copy of it to the Erecting Contractor.

This design is for an individual building component, not a truss system. It has been based on specifications provided by the component manufacturer and has been completed in accordance with the current versions of TPI and AFPA design standards. No responsibility is assumed for dimensional accuracy. Dimensions are to be verified by the component manufacturer and/or building designer prior to fabrication. The building designer shall ascertain that the loads utilized on this design meet or exceed the loading imposed by the local building code and the particular application. This design assumes that the top chord is laterally braced by the roof or floor sheathing and that the bottom chord is laterally braced by a rigid sheathing material directly attached, unless otherwise noted. Bracing shown is for lateral support of individual component members only. This component shall not be placed in any environment that will cause the moisture content of the wood to exceed 19% and/or cause connector plate corrosion. Fabricate, handle, install, and brace this truss in accordance with the following standards: SPACEJOIST TRUSS FABRICATION MANUAL, by Trusswale Systems; Handling, Installing, and Bracing Metal Plate Connected Wood Trusses (HIB-91 and HIB-91 Summary Sheet) by TPI. The Truss Plate Institute is located at 583 D'Onofrio Dr., Ste. 200, Madison, WI 53719. The American Forest and Paper Association (AFPA) is located at 1111 19th St. N.W., Ste. 800, Washington, DC 20036.

CHK: Dsgnr: DL	Customer Name: SpaceJoist TE
TC Live 40 psf	DurFacs: L= 1.00 P= 1.00
TC Dead See Span Table	Rep Mbr Bnd: 1.15
BC Live 0 psf	Spacing: See Span Table
BC Dead 5 psf	Design Spec: TPI
TOTAL See Span Table	

Trimable End
SpaceJoist
 1101 North Great Southwest Parkway
 Arlington, Texas 76011

DATE: 01/14/03

DESIGNED BY TRUSSWAL SYSTEMS

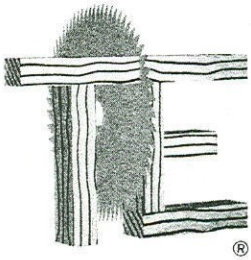

SpaceJoist TE, LLC

1101 N. GREAT SOUTHWEST PARKWAY • ARLINGTON TEXAS 76011-7717 • 817-633-5022

TX96284011-001

(Revised 5-03-01)

SpaceJoist TE Standard Notes

SpaceJoist TE – Assembly Notes:

1. The Trimmable end detail is formed by creating an I-section from a 15/32" thick OSB web glued into routed notches in the truss chord flanges.
2. Materials and procedures utilized in the manufacture of SpaceJoist TE trusses shall be in accordance with specifications of the SpaceJoist TE Quality Assurance Program.
3. Manufacturing of all SpaceJoist TE product shall be accomplished only at those manufacturing facilities specified by SpaceJoist TE, LLC.
4. Manufacturing of the SpaceJoist TE product shall be inspected by a qualified independent third party inspection agency.

SpaceJoist TE – General Truss Notes

1. Spans shown on SpaceJoist TE design drawings reflect the use of composite action between the floor decking and the truss. Deflection limitations have been adjusted to take advantage of this behavior. Composite action requires that a minimum of 3/4" (23/32") tongue and groove 48/24 Exposure 1 APA span rated sheathing be used for 24" o.c. and 19.2" o.c. joist spacing. A minimum of 5/8" (19/32") tongue and groove 40/20 Exposure 1 APA span rated sheathing is required for joist spacing of 16" o.c. or less. These are minimums. Governing codes or design requirements may necessitate a thicker sheathing. The decking shall be glued and screwed OR glued and nailed (as required per code) to the top chord of the truss utilizing a construction adhesive conforming to APA Specification AFG-01. All tongue and groove joints of the floor decking must be glued with the same adhesive.
2. Refer to the appropriate truss drawing when the maximum allowable truss span is less than the truss drawing span.
3. SpaceJoist TE designs require the use of an adequate rim joist capable of supporting loads from stacked walls at the truss ends. Wall loads are not permitted to be applied directly to the ends of the truss.
4. 2x6 continuous strongback bridging spaced a maximum of 10'-0" o.c. is required for all spans exceeding 12'-0". See Detail S of the "SpaceJoist TE Design & Specification Guide" or the "SpaceJoist TE Installation Poster" for installation details.
5. When rigid sheathing is not directly attached to the bottom chord, install 1x4 continuous lateral bracing to the bottom chord at intervals of 10'-0" o.c.

MEA 262-03-E

51 of 51 pages

Sales: 800 • 238-8678
Website: www.spacejoist.com

Fax: 817 • 652-3079
E-mail: info@spacejoist.com



NOV 13 2003