



BUILDINGS 2023-017 BULLETIN TECHNICAL

ISSUANCE DATE
October 26, 2023



ISSUER: Keith L. Wen, R.A. 
Assistant Commissioner
Code & Zoning Interpretation

PURPOSE: This Bulletin clarifies the applicability of the New York City Building Code provisions for exit access stair enclosures (BC 1019.3, Exception 3) in one- and two-family dwellings.

SUBJECT(S): One- and two-family dwellings, Shaft Enclosures, Interior Exit Stairs, Exit Access Stairs, Automatic Sprinkler Systems

RELATED CODE SECTIONS: BC 712.1.2; BC 903.2.8; BC 1019.3, Exception 3

I. BACKGROUND

Section BC 1019.3 of the 2022 NYC Building Code requires that in occupancies other than groups H, I-2, and I-3, all exit access stairs must be enclosed, except as specifically provided. Exception 3 to that section allows for unenclosed exit access stairs in fully-sprinklered Group R occupancies that connect four stories or less and which are contained within an individual dwelling unit.

Section BC 712.1.2 works complementarily with Section BC 1019.3, Exception 3 by limiting unconcealed vertical openings within fully sprinklered dwelling units to four stories or less.

Section BC 903.2.8, which generally requires sprinkler systems in Group R occupancies, specifically exempts from the sprinkler requirement all detached one- and two-family dwellings and multiple single-family dwellings (townhouses) that are 3 stories or less above the grade plane and have separate means of egress for each dwelling. Such occupancies satisfy the height requirement of section BC 1019.3, Exception 3 as well as the requirement for each dwelling unit to have its own means of egress. Because these occupancies do not require a sprinkler system, a plain reading of Exception 3 would require any exit stairs to be fully enclosed.

The purpose of this Building Bulletin is to clarify the applicability of section BC 1019.3, Exception 3 to those occupancies that are exempt from sprinkler requirements in section BC 903.2.8.

II. CLARIFICATION

Under the exception to section BC 903.2.8, no sprinkler systems are required for detached one and two-family dwellings and multiple single-family dwellings (townhouses), provided that such occupancies are not more than 3 stories above grade plane and have separate means of egress for each dwelling. Since such occupancies satisfy the height limitations of section BC 1019.3, Exception 3 as well as the requirement for each dwelling unit to have its own means of egress, and such occupancies are exempt from having sprinkler systems, they are permitted to use unenclosed exit access stairs as a means of egress component to a required exit within an individual dwelling unit.

For the purposes of Exception 3 of section BC 1019.3, note that basements, cellars, and finished attics accessed via stairs within the same unit count as stories. The means of egress using unenclosed exit access stairs as an exit access component must comply with travel distance requirements of section BC 1017.

III. EXAMPLES

Example 1: Sprinkler not Required & Unenclosed Stair

Detached one-family dwelling, three stories above grade plane

A detached 1-family dwelling has a basement, a ground floor and a second floor. These stories are connected by a common stair. Because the dwelling is not more than 3 stories above the grade plane, it is not required to be sprinklered per the exception to BC 903.2.8. The dwelling is permitted to use an unenclosed exit access stair as a means of egress to a required exit (*Figure 1*).

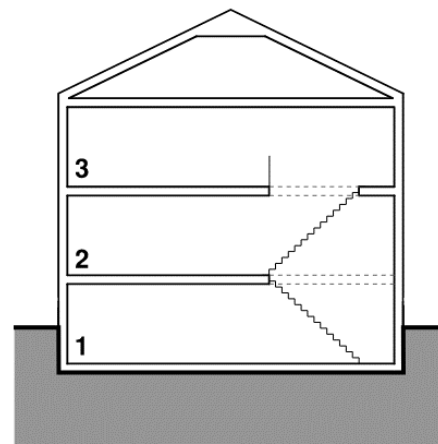

Figure 1

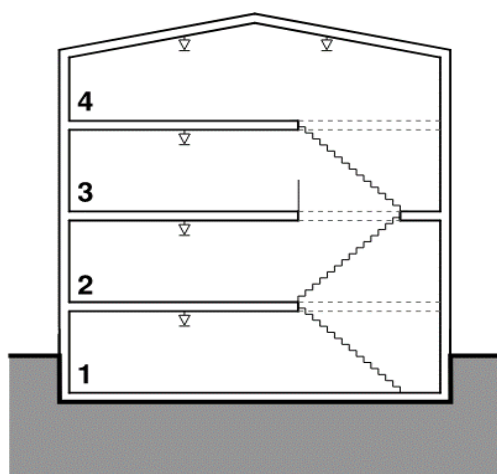

Figure 2

(sprinklers shown for diagrammatic purposes only)

Example 2: Sprinkler Required & Unenclosed Stair

Detached one-family dwelling, four stories above grade plane

A detached 1-family dwelling has a basement, a ground floor, a second floor and a third floor. All floors are accessed via a common stair. Because the dwelling is more than 3 stories above the grade plane, BC 903.2.8 requires an automatic sprinkler system. The dwelling is permitted to use an unenclosed exit access stair as a means of egress to a required exit (*Figure 2*).

Example 3: Sprinkler & Enclosed Stair Required

Detached one-family dwelling, five stories above grade plane

A detached 1-family dwelling has a basement, a ground floor, a second floor, a third floor and a fourth floor. All floors are accessible via a common stair. Although the 5-story building is fully sprinklered pursuant to BC 903.2.8, the stair connects more than 4 stories. Because BC 1019.3, Exception 3 only applies to stairs connecting 4 stories or less, the interior exit stair must be enclosed (*Figure 3*).

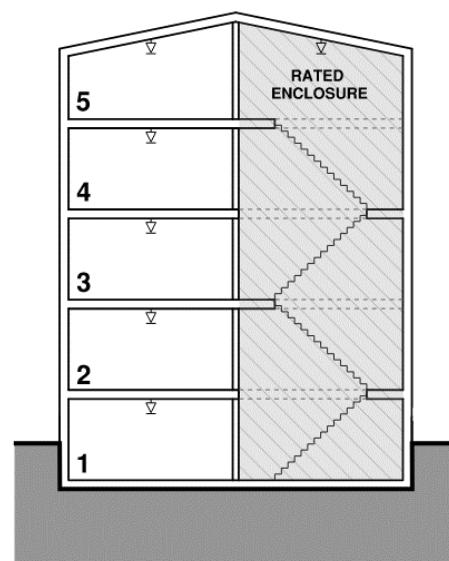

Figure 3

(sprinklers shown for diagrammatic purposes only)