



BUILDINGS BULLETIN 2019-004

Technical

Supersedes: 2019-003

Issuer: Gus Sirakis, P.E.
First Deputy Commissioner

Issuance Date: July 30, 2019

Purpose: This document serves as educational material to inform individuals of a building owner's obligation to make single-occupant toilet rooms available for persons of all sexes.

Related Code/Zoning Section(s):	AC 28-103.32	PC 403	BC 1110	LL79/2016
	AC 28-315.9	PC 403.2.1	A117.1 703	
	PC 202	PC 403.4		

Subject(s): Single-occupant Toilet Room; Signage Requirements

I. Description

This bulletin provides guidance on the building owner's obligation to make single-occupant toilet rooms available to persons of all sexes, and appropriate signage options for buildings with single-occupant toilet rooms.

II. Background

Local Law 79 of 2016 amended the New York City Administrative Code (AC), the New York City Plumbing Code (PC), and the New York City Building Code (BC), in relation to single-occupant toilet rooms.

AC Section 28-315.9 established a retroactive provision that all single-occupant toilet rooms, including those existing before January 1, 2017, and those that are constructed on or after January 1, 2017, shall be made available for use by persons of all sexes in accordance with Section 403.2.1 of the New York City Plumbing Code. No physical alterations are required to such single-occupant toilet room, except for the posting and maintenance of appropriate signage in accordance with Section 403.4 of the New York City Plumbing Code.

Section PC 202 defines 'single-occupant toilet room' as, in part:

"...a toilet room with no more than one water closet and no more than one urinal."

This type of toilet room is provided with a lockable door securable from within, and affords the privacy desired for a single user of the toilet room. Signage must be posted on the wall, adjacent to the door of such toilet room, in accordance with item III of this Bulletin.

The following instances do not require signage as described in this bulletin:

1. Toilet rooms that contain multiple water closets in separate water closet compartments or multiple urinals with privacy walls or partitions.
2. A toilet room with one urinal and a door to such room that is not securable from within.
3. Single-occupant toilet rooms that egress through a room permissibly restricted by sex, such as a single-occupant toilet room accessible only from a men's or women's locker room.

III. Specifics

A single-occupant toilet room, as defined by Section PC 202, shall be designated by proper signage.

All toilet room signage shall be installed in accordance with Section 1110 of the New York City Building Code, and Section 703 of ICC A117.1 – 2009 Edition. Signage must be posted on the wall, in accordance with Sections 703.3.10 and 703.3.11 of ICC A117.1. While the Department does not specify the required pictorial images, the following illustrates compliant images, including one for accessible single-occupant toilet room:

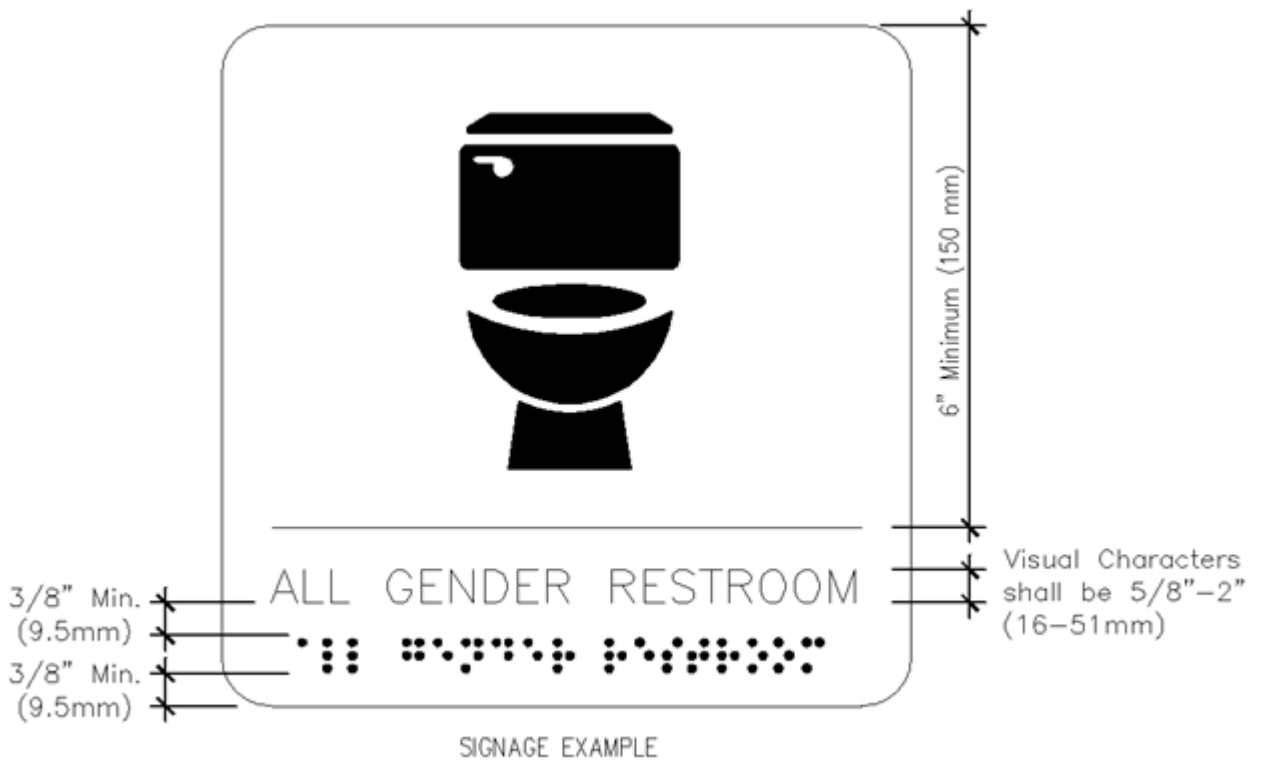



SIGNAGE EXAMPLE

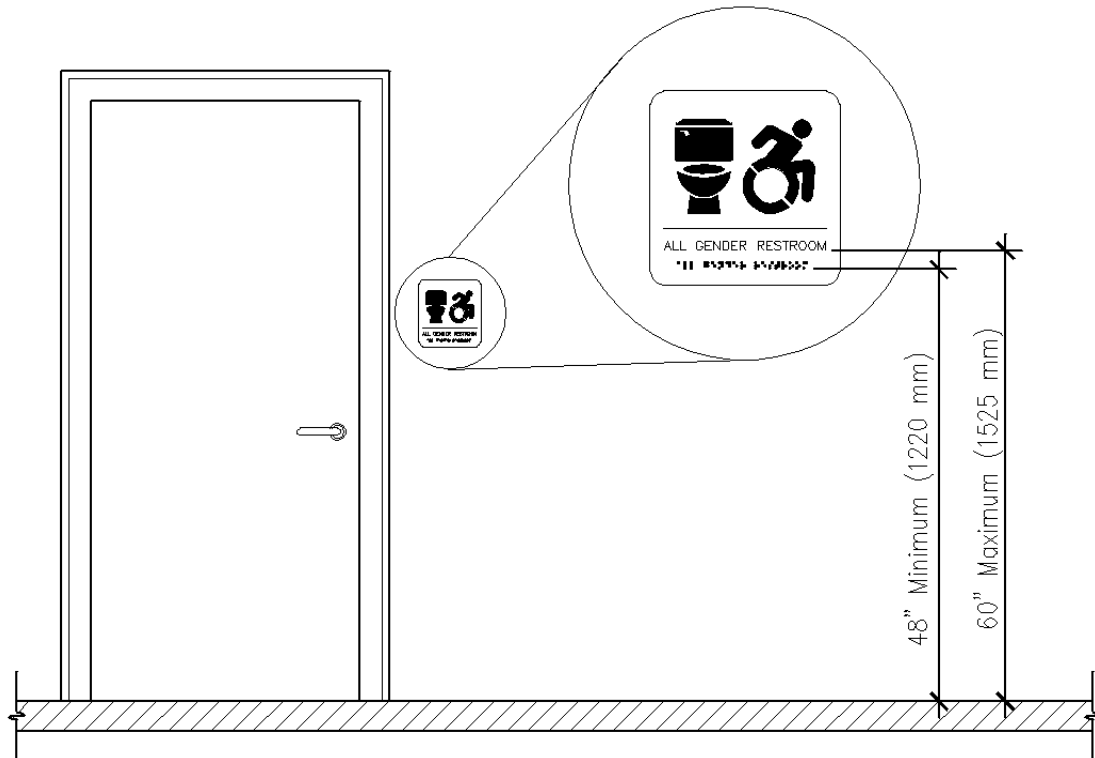

HEIGHT OF SIGNAGE ABOVE FINISHED FLOOR

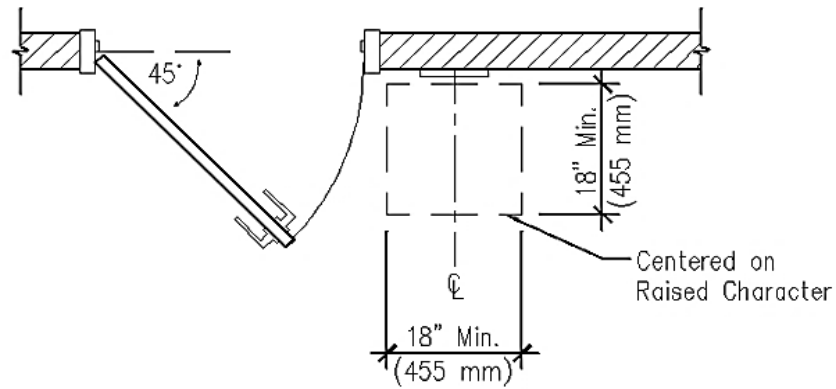

LOCATION OF SIGNAGE AT DOORS

IV. Submitting a Complaint

Any single-occupant toilet room without adequate signage as described in this bulletin can be reported to New York City's 311 complaint system at either <https://www1.nyc.gov/311/> or by dialing 311.