

**A. INTRODUCTION**

This chapter considers the effects of the proposed actions on urban design and visual resources. The proposed actions would result in a mixed-use development on an approximately 6.6-acre site, which consists of ten City-owned sites (of which nine would be developed) and areas of streets to be mapped and demapped on the Lower East Side of Manhattan (together encompassing the “project site”).

Under the *City Environmental Quality Review (CEQR) Technical Manual* (January 2012 edition), urban design is defined as the totality of components that may affect a pedestrian’s experience of public space. These components include streets, buildings, visual resources, open spaces, natural resources, wind, and sunlight. An urban design assessment under CEQR must consider whether and how a project may change the experience of a pedestrian in a project area. The *CEQR Technical Manual* guidelines recommend the preparation of a preliminary assessment of urban design and visual resources, followed by a detailed analysis if warranted based on the conclusions of the preliminary assessment. The analysis provided below addresses urban design characteristics and visual resources for existing conditions, the future without the proposed actions, and the probable impacts of the proposed actions.

**PRINCIPAL CONCLUSIONS**

Overall, this analysis concludes that the proposed actions would not have any significant adverse impacts related to urban design and visual resources.

**B. PRELIMINARY ASSESSMENT**

Based on the *CEQR Technical Manual*, a preliminary assessment of urban design and visual resources is appropriate when there is the potential for a pedestrian to observe, from the street level, a physical alteration beyond that allowed by existing zoning. Examples include projects that permit the modification of yard, height, and setback requirements, and projects that result in an increase in built floor area beyond what would be allowed “as-of-right” in the future without the proposed actions.

To facilitate the redevelopment of the project site, a number of discretionary actions would be required, including zoning map and text amendments, zoning special permits, street mappings and demappings, and the disposition of City-owned property. The zoning changes would permit the creation of a Large-Scale General Development (LSGD) and the modification of bulk requirements. Therefore, while the proposed actions do not constitute an upzoning, they would be expected to result in physical alterations beyond that allowed by existing zoning, and thus would meet the threshold for a preliminary assessment of urban design and visual resources.

The *CEQR Technical Manual* guidelines state that if the preliminary assessment shows that changes to the pedestrian environment are sufficiently significant to require greater explanation and further study, then a detailed analysis is appropriate. Examples include projects that would

potentially obstruct view corridors, compete with icons in the skyline, or make substantial alterations to the streetscape of a neighborhood by noticeably changing the scale of buildings. Detailed analyses also are generally appropriate for area-wide rezonings that include an increase in permitted floor area or changes in height and setback requirements, large-scale general developments (LSGDs), or projects that would result in substantial changes to the built environment of a historic district or components of a historic building that contribute to the resource's historic significance. Conditions that merit consideration for further analysis of visual resources include when the project partially or totally blocks a view corridor or a natural or built visual resource that is rare in the area or considered a defining feature of the neighborhood; or when the project changes urban design features so that the context of a natural or built visual resource is altered (i.e., if the project alters the street grid so that the approach to the resource changes; if the project changes the scale of surrounding buildings so that the context changes; or if the project removes lawns or other open areas that serve as a setting for the resource).

The proposed actions would involve changes to nine of ten proposed development sites over a 6.6-acre site and could potentially make noticeable alterations to the streetscape of the surrounding area by noticeably changing the scale of buildings, compared to the future without the proposed actions. In many cases, sites would go from being wholly or partially developed with surface parking lots to being nearly or completely occupied by structures ranging in height from 80 to 285 feet tall (or up to 315 feet with bulkheads). Therefore, the proposed actions would meet the threshold for a detailed assessment of urban design and visual resources. This analysis is provided below.

### C. METHODOLOGY

As defined in the *CEQR Technical Manual*, urban design is the totality of components that may affect a pedestrian's experience of public space. This detailed assessment considers the effects of the proposed actions on the experience of a pedestrian in the study area. The assessment focuses on those project elements that have the potential to alter the built environment, or urban design, of the project area, which is collectively formed by the following components:

- Streets—the arrangement and orientation of streets define location, flow of activity, street views, and create blocks on which buildings and open spaces are arranged. Other elements including sidewalks, plantings, street lights, curb cuts, and street furniture also contribute to an area's streetscape.
- Buildings—a building's size, shape, setbacks, pedestrian and vehicular entrances, lot coverage and orientation to the street are important urban design components that define the appearance of the built environment.
- Visual Resources—visual resources include significant natural or built features, including important views corridors, public parks, landmarks structures or districts, or otherwise distinct buildings.
- Open Space—open space includes public and private areas that do not include structures including parks and other landscaped areas, cemeteries, and parking lots.
- Natural Features—natural features include vegetation and geologic and aquatic features that are natural to the area.

The *CEQR Technical Manual* recommends an analysis of pedestrian wind conditions for projects that would result in the construction of large buildings at locations that experience high wind conditions (such as along the waterfront, or other location where winds from the waterfront

are not attenuated by buildings or natural features), which may result in an exacerbation of wind conditions due to “channelization” or “downwash” effects that may affect pedestrian safety. The project site is not within a location that experiences high wind conditions. Therefore, a pedestrian wind conditions analysis has not been prepared.

The study area for the urban design and visual resources analysis has been defined as the area within approximately 400 feet of the project site. This study area roughly extends from Houston Street to the north, Grand Street to the south, Suffolk and Ridge Streets to the east, and Allen Street to the west (see **Figure 8-1**). The study area for visual resources has been extended to consider longer view corridors along Delancey Street and from the Williamsburg Bridge.

**D. EXISTING CONDITIONS**

**URBAN DESIGN**

*PROJECT SITE*

The project site is 6.6 acres in size and includes ten sites (see **Figure 8-2**). Sites 1 through 6 are located south of Delancey Street, between Ludlow and Ridge Streets; Sites 7 through 10 are north of Delancey Street, oriented along Essex Street. **Table 8-1** provides information on each site’s lot area, built floor area, and lot coverage.

**Table 8-1  
Proposed Development Sites – Existing Conditions**

Site No.	Lot Area (sf)	Building Area (sf)	Allowable FAR	Built FAR	Lot Coverage Percentage
1	21,996	—	6.0 (commercial), 0.87-3.44 (residential), 6.5 (community facility)	N/A	0
2	43,140	17,995	6.0 (commercial), 0.87-3.44 (residential), 6.5 (community facility)	0.42	35
3	40,776	—	0.94-6.02 (residential), 6.5 (community facility)	N/A	0
4	40,627	—	0.94-6.02 (residential), 6.5 (community facility)	N/A	0
5	60,712	3 buildings: 8,400; 12,500; 5,700	0.94-6.02 (residential), 6.5 (community facility)	0.52	15
6	21,344	—	0.94-6.02 (residential), 6.5 (community facility)	N/A	0
7	22,402	132,750	4.0 (commercial, residential, community facility)	5.93	100
8	11,210	11,210	4.0 (commercial, residential, community facility)	1.00	100
9	20,817	20,750	6.0 (commercial), 6.02 (residential), 6.5 (community facility)	1.02	100
10	6,840	6,840	4.0 (commercial, residential, community facility)	1.00	100
<b>Notes:</b> All numbers above are best estimates. The demapped sections of Suffolk and Broome Streets that would be mapped total approximately 45,786 square feet. The mapped sections of Clinton and Delancey Streets that would be demapped total approximately 17,580 square feet. Site 7 would not be redeveloped under the proposed actions, but is included for informational purposes.					

Site 1 is an L-shaped lot on the southern half of the block bounded by Delancey, Ludlow, Broome, and Essex Streets. It is occupied by a paved surface parking lot and surrounded by chain link fencing. The site has frontages on Ludlow, Broome, and Essex Streets, and the

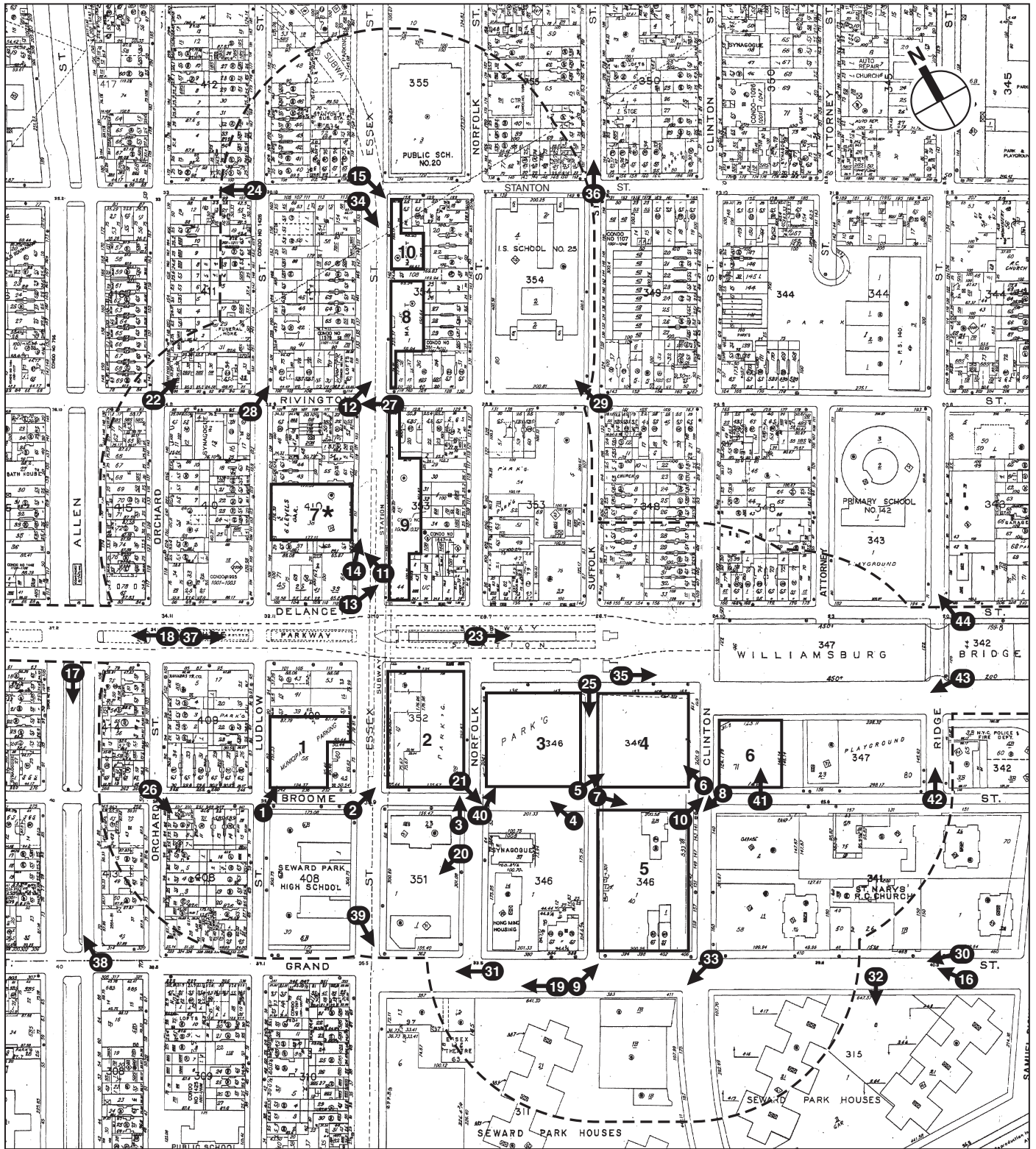

- 1** Proposed Development Sites
- \* Site 7 Would Not Be Redeveloped Under the Proposed Actions
- - - Study Area Boundary (400-Foot Perimeter)
- 1** → Photograph View Direction and Reference Number

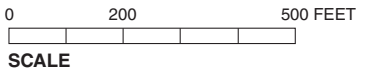



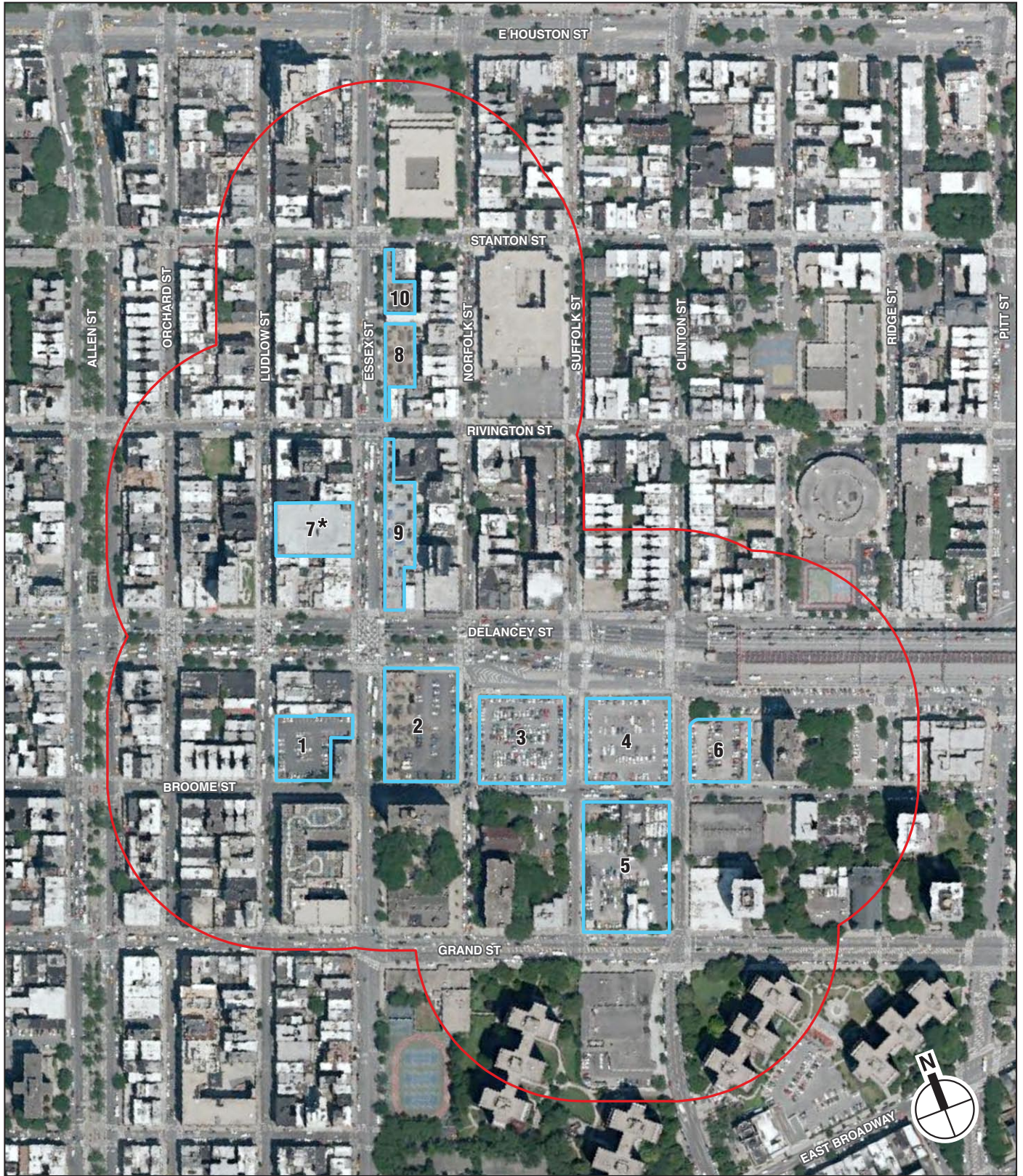

- 1 Proposed Development Sites
- \* Site 7 Would Not Be Redeveloped Under the Proposed Actions
- Study Area Boundary (400-Foot Perimeter)

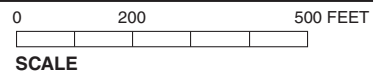

Aerial Photograph  
of Development Sites and Study Area  
**Figure 8-2**



## Seward Park Mixed-Use Development Project

---

vehicular entrances are on Ludlow and Essex Streets (see View 1 of **Figure 8-3**). There are street trees located along the site's Ludlow Street frontage.

Site 2 is the entire block bounded by Delancey, Norfolk, Broome, and Essex Streets. A one-story, brick utilitarian building—formerly one of four Essex Street Market buildings—occupies the site's full Essex Street frontage (see Views 2 and 3 of **Figures 8-3** and **8-4**). The remainder of the site is occupied by a paved surface parking lot, surrounded by chain link fencing. Along Essex Street the building is mostly vacant, but it contains a liquor store and diner along its Delancey Street frontage. There is also a subway station exit in the ground-floor on Essex Street; the subway entrance is in the adjacent sidewalk. Street trees are located along the Essex Street frontage.

Site 3 is the block bounded by Delancey, Suffolk, Broome, and Norfolk Streets, and Site 4 is the block bounded by Delancey, Clinton, Broome, and Suffolk Streets (see Views 4-6 of **Figures 8-4** and **8-5**). These sites are occupied by paved surface parking lots surrounded by chain link fencing.

Site 5 is the block bounded by Broome, Clinton, Grand, and Suffolk Streets. Site 5 contains three buildings: a 5-story, brick tenement building fronting on Grand Street, that has a ground-floor visitor center for the Lower East Side Jewish Conservancy (LESJC); an adjacent 3-story, brick building with retail on the ground floor and vacant space above; and a 2-story, brick former fire station on Broome Street (see Views 7-9 of **Figures 8-6** and **8-7**). Surrounding these buildings, and occupying the remainder of the site, is a paved surface parking lot surrounded by chain link fencing. There are a small number of trees on and at the perimeter of the parking lot.

Site 6 is a square-shaped lot on the western side of the block bounded by Delancey, Clinton, Ridge, and Broome Streets. The site has frontages on Unnamed, Clinton, and Broome Streets. It is occupied by a paved surface parking lot surrounded by chain link fencing (see View 10 of **Figure 8-7**). There are gaps in the lot's pavement, allowing low vegetation to grow; there are also some trees at the perimeter of the lot.

Sites 1 through 6 together currently comprise the largest, under-developed City-owned sites in Manhattan south of 96th Street. In general, the pedestrian experience on the streets surrounding these sites is not an active or aesthetically appealing one. With the exception of a few uses on Site 2 and the LESJC and small retail uses on Site 5, there are no retail or other ground-floor building uses to draw pedestrians to the sites; and the streets themselves are unevenly paved and the striping is faded. There are few street trees or street furniture adjacent to these sites.

Site 7, which would not be redeveloped under the proposed actions, is a large, rectangular-shaped lot in the middle of the block bounded by Ludlow, Delancey, Rivington, and Essex Streets. The through-block site is occupied by a 6-level public parking garage with access/egress points on Essex and Ludlow Streets (see View 11 of **Figure 8-8**). The garage is clad in brick and vertical concrete ribbing.

Site 8 is a narrow, irregular-shaped lot fronting on Essex Street, on the southern portion of the block bounded by Essex, Stanton, Rivington, and Norfolk Streets. Like Site 2, Site 8 is occupied by a former Essex Street Market building; the one-story brick building on Site 8 is similar in appearance to the building on Site 2 (see View 12 of **Figure 8-8**). This building has no active ground-floor uses and is currently used for the storage of garbage generated by the current Essex Street Market building on Site 9.



Site 1, looking north from Broome Street 1

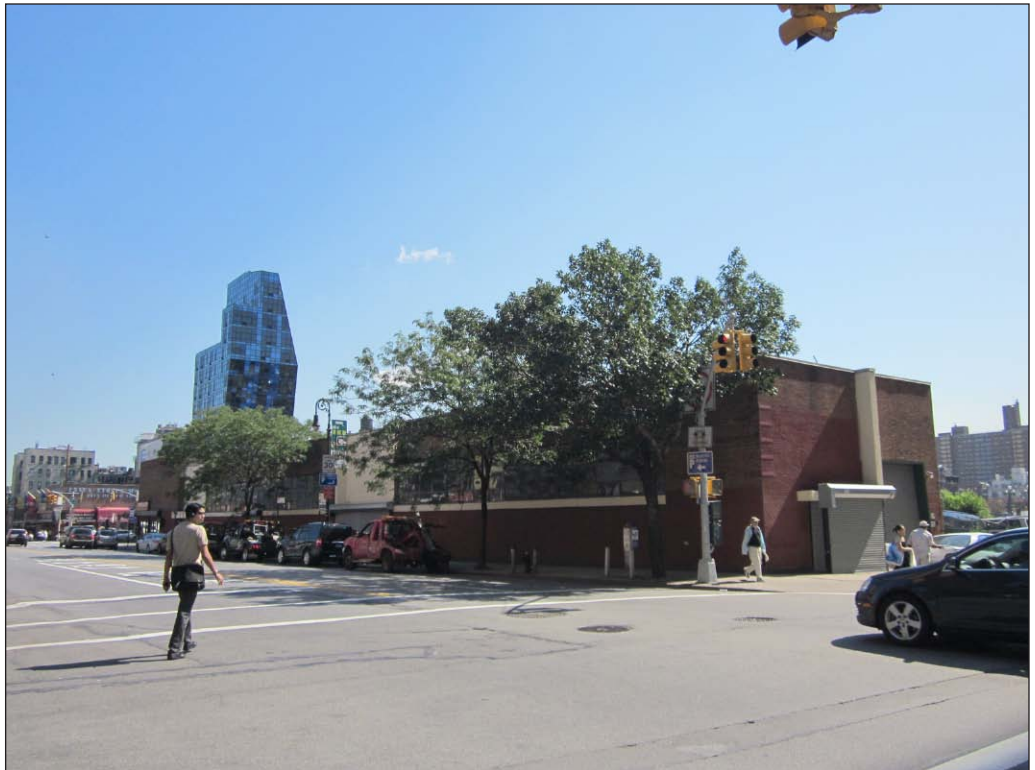

Site 2, looking northeast from Broome and Essex Streets 2

Photographs of Development Sites  
Views 1 & 2  
**Figure 8-3**



Site 2, looking north from Broome and Norfolk Streets 3



Site 3, looking northwest from Broome Street 4

Photographs of Development Sites  
Views 3 & 4  
Figure 8-4





Site 4, looking east from Broome and Suffolk Streets 5



Site 4, looking northwest from Broome and Clinton Streets 6

Photographs of Development Sites  
Views 5 & 6  
Figure 8-5





Site 5, looking southeast from Broome and Suffolk Streets 7



Site 5, looking southwest from Broome and Clinton Streets 8

Photographs of Development Sites  
Views 7 & 8  
**Figure 8-6**



Site 5, looking northeast from Grand and Suffolk Streets 9



Site 6, looking northeast from Broome and Clinton Streets 10

Photographs of Development Sites  
Views 9 & 10  
Figure 8-7





Site 7, looking northwest from Essex Street 11



Site 8, looking northeast from Rivington Street 12

Photographs of Development Sites  
Views 11 & 12  
Figure 8-8

Site 9 is a narrow, irregular-shaped lot fronting on Essex Street. It occupies most of the western half of the block bounded by Rivington, Delancey, Essex, and Norfolk Streets. The site contains one of the four original Essex Street Market buildings and is the only one of the buildings to currently contain a public market. The building is similar in design to the former market buildings on Sites 2, 8, and 10 (which is described below) (see Views 13 and 14 of **Figure 8-9**). There are colorful advertising banners affixed at various locations along the building's Essex Street and Delancey Street façades. It also contains a restaurant with its entrance on the Rivington Street frontage, and small retail spaces on Delancey Street. There is a subway station exit in the ground-floor on Essex Street; a subway entrance is located in the adjacent sidewalk.

Site 10 is a narrow lot fronting on Essex Street, on the northern portion of the block bounded by Essex, Stanton, Rivington, and Norfolk Streets. Like the buildings on Sites 2, 8, and 9, the one-story brick building on Site 10 is a former Essex Street Market building; this building currently houses a health clinic (see View 15 of **Figure 8-10**).

Unlike the pedestrian experience of Sites 1–6, the pedestrian experience of Sites 7–10 is not notably different than that of neighboring portions of the study area. While Sites 7 and 8 do not have active ground-floor uses, Sites 9 and 10 do, and all sites contain structures that are built to the lot line. The ground-floor uses on Sites 9 and 10 bring pedestrian and vehicular activity to Essex Street, which is lined with other ground-floor retail, commercial, and institutional uses. The subway station entrance and exit at Site 9 also brings pedestrian activity to this portion of the project site. The metal roll-down gates covering building entrances on the sites are consistent with the appearance of security gates used at other nearby buildings.

The project site also includes a demapped section of Suffolk Street between Grand and Delancey Streets, a demapped section of Broome Street between Norfolk and Clinton Streets, a mapped section of Delancey Street between Norfolk and Clinton Streets, and a mapped section of Clinton Street between Grand and Delancey Streets. Although the project site sections of Suffolk and Broome Streets are demapped, they look and function as mapped streets with paved travel lanes, curbs, and sidewalks. They do contain some areas of exposed Belgian block paving where the asphalt overlayer has worn away. The sidewalks along the streets included within the project site are of varying width, weathered and occasionally overgrown, and lined by chain link fencing.

#### *STUDY AREA*

The street pattern in the study area is generally a grid system, which creates rectangular, north-south oriented blocks. Several superblocks interrupt this pattern within the portion of the study area south of Delancey Street, creating longer walking intervals for pedestrians. The superblocks include the area bounded by Clinton, Ridge, Delancey, and Broome Streets (which includes Site 6); the block just to the south, which is bounded by Clinton, Pitt, Broome, and Grand Streets and occupied by the 26-story (232-foot-tall) Seward Park Extension houses, St. Mary's Church with its twin corner towers, a parking garage, and other assorted small-scale structures (see View 16 of **Figure 8-10**); and the superblocks containing the Seward Park Houses (described below), which are bounded by Grand, Essex, Canal, East Broadway, Clinton, and Pitt Streets. Just south of the study area the street pattern changes, with East Broadway and other streets that parallel the East River shoreline angling from southwest to northeast to intersect with Grand Street just east of Bialystoker Place.

Most of the study area's pedestrian and vehicular traffic is focused in the area along and north of Delancey Street; south of Delancey Street, particularly around Sites 2–6, there is less pedestrian

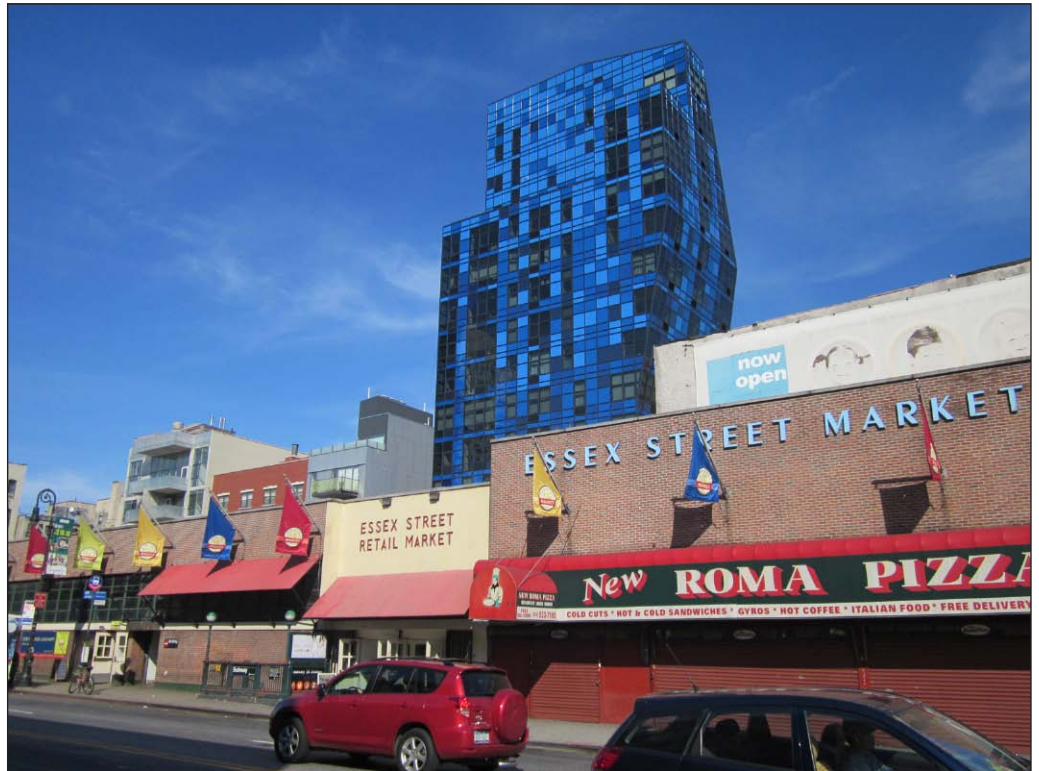

Site 9, looking east from just north of Delancey Street 13

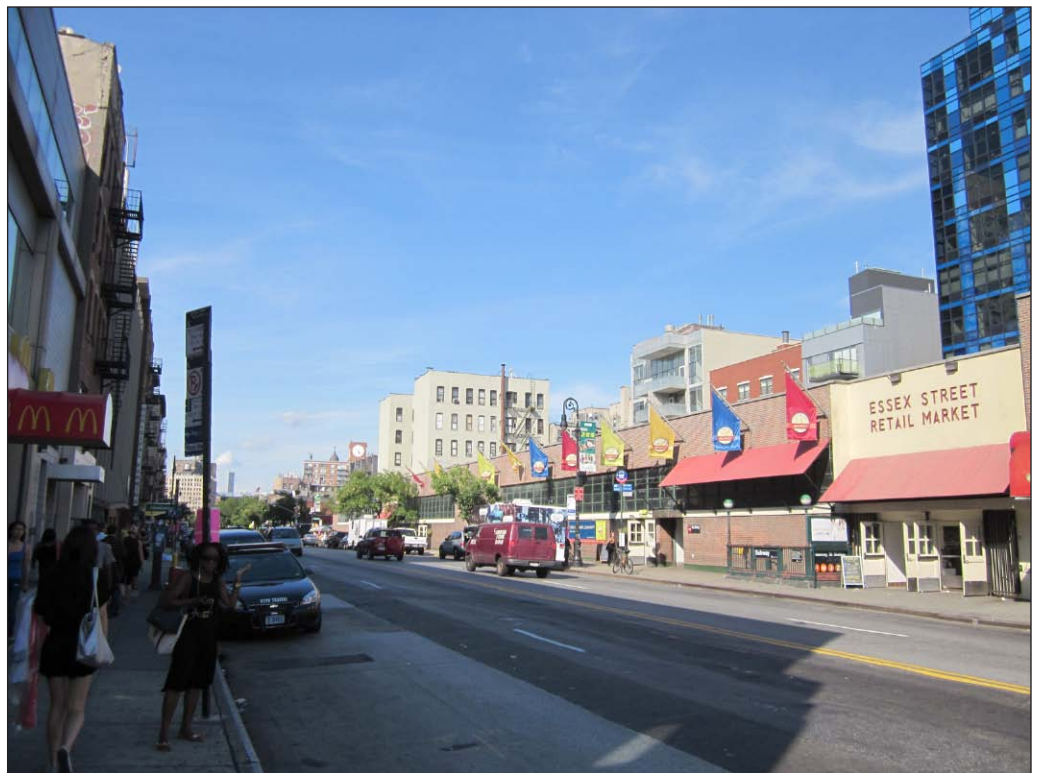

Site 9, looking northeast from Essex Street near Delancey Street 14

Photographs of Development Sites  
Views 13 & 14  
Figure 8-9





Site 10, view southeast from Essex and Stanton Streets 15



North side of Grand Street, view from Pitt Street 16

Photographs of Development Sites and Study Area  
Views 15 & 16

## Seward Park Mixed-Use Development Project

---

or vehicular traffic. In part, the higher pedestrian traffic north of Delancey Street and west of Ludlow Street south of Delancey Street is due to the greater amount of street-level retail and restaurant uses in these areas and the activity these uses generate. The major thoroughfares through the study area are Delancey, Allen, Essex, Broome, and Grand Streets; other important, but more local, streets include Norfolk, Suffolk, and Clinton Streets.

Delancey Street runs in an east-west direction and carries vehicular, bicycle, and pedestrian traffic to the Williamsburg Bridge, the access point for which is at the eastern edge of the study area around Clinton Street. Allen Street runs north-south. Both streets include protected bicycle paths, which appear to be well used, and a landscaped median with trees that provide visual relief and shade for pedestrians and bicyclists (see Views 17 and 18 of **Figure 8-11**). In addition, portions of Delancey Street are classified as “greenstreets.” The Allen Malls, which extend along Allen Street between East Houston Street and East Broadway, also include benches and walkways. The Malls are currently being renovated. On Delancey Street, the bike path begins at Suffolk/Clinton Street and continues over the bridge. Essex is a two-way street and is wider than adjacent north-south streets, which are one-way only. In the weekday evening rush hour, left turns from Essex Street onto Delancey are prohibited; therefore, at those times vehicles traveling south on Essex Street headed for the Williamsburg Bridge travel past its intersection with Delancey Street and turn left onto Broome Street, and left again onto Norfolk Street, creating evening congestion at the intersection of Norfolk Street and Broome Street.

Grand Street also runs in an east-west direction, at the southern end of the study area, but appears less congested with vehicular traffic than Delancey and Allen Streets. Grand Street provides a painted, non-protected bicycle lane, as do Stanton, Rivington, Suffolk, and Clinton Streets. Grand Street also has a wide median, some portions of which are landscaped (see View 19 of **Figure 8-12**). The remainder of the cross streets in the study area are generally one-way and less traveled. North of Delancey Street, Orchard Street becomes a pedestrian-only thoroughfare on Sundays.

The topography of the study area is generally flat, with slight slopes downward toward the East River and from Grand Street to Delancey Street. There are no natural features within the study area. The area’s public open spaces are mainly playgrounds associated with public schools and public and privately owned housing complexes, including P.S. 142, P.S. 20, William H. Seward High School, and the Broome Seward Park Extension (see View 20 of **Figure 8-12**). There are also a few community gardens in the study area. There are some street trees throughout the study area, mostly along Essex Street, and more extensive vegetation on the open lots surrounding the Gothic Revival-style former synagogue of the Beth Hamedrash Hagadol congregation and the Seward Park Houses, described below (see View 21 of **Figure 8-13**). In general, the preponderance of fully developed sites north of Delancey Street and the paved parking lots surrounded by chain-link fencing south of Delancey Street give the pedestrian’s experience of this area a distinct visual character, which is reinforced by cars parallel parked on streets, concrete sidewalks, ground-floor retail uses, the typical open-mesh and metal roll-down gates used to secure ground-floor openings, and the presence of typical street furniture (e.g. bus shelters, newspaper bins, parking meters, transportation and other signage, trash bins).

Other elements that contribute to the pedestrian’s experience of the study area streetscape include the large directional signage on gantries above Delancey Street leading to the Williamsburg Bridge and above Orchard Street providing information regarding its car-free operation on Sundays (see Views 22 and 23 of **Figures 8-13** and **8-14**). Although most of the lampposts in the area are of modern design, there are also a three-armed traffic light at the





Allen Street Malls, view south from Delancey Street 17



Delancey Street, view west from Orchard Street 18

Photographs of Study Area  
Views 17 & 18  
Figure 8-11





Grand Street, view west from Suffolk Street 19



Broome Seward Park Extension playground 20

Photographs of Study Area  
Views 19 & 20  
**Figure 8-12**





Southeast corner of Broome and Norfolk Streets 21



View north on Orchard Street from Rivington Street 22

Photographs of Study Area  
Views 21 & 22  
Figure 8-13





Delancey Street, view east from Norfolk Street 23



View west on Stanton Street from Ludlow Street 24

Photographs of Study Area Views 23 & 24  
Figure 8-14

northeast corner of Suffolk and Broome Streets and historic reproduction bishop's crook lampposts within the boundaries of the Lower East Side Historic District (see Chapter 7, "Historic and Cultural Resources") (see View 24 of **Figure 8-14**). Some of the streets in the study area also have historic Belgian block paving, including: Orchard Street south of Delancey Street; Suffolk Street north of Grand Street; Suffolk Street between Broome and Delancey Streets; and Broome Street between Suffolk and Clinton Streets. The historic and reproduction lampposts and street paving materials contribute to the pedestrian's understanding of the layers of built history that remain in this area. The pavement of other streets, specifically those around the project sites south of Delancey Street, is uneven and the striping is faded, giving this area a more deteriorated appearance to pedestrians (see View 25 of **Figure 8-15**).

As described below, the buildings in the portions of the study area north of Delancey Street and west of Essex Street are generally built at or close to the street line, creating strong streetwalls. There are some exceptions to this pattern, such as for historic tenements and modern row houses set back from the lot line, with stoops leading to the second-floor main entrances. Other setbacks from the lot line in this area include P.S. 20's frontage on Stanton Street, which is set back behind a paved playground well shaded by street trees. Some streets, including Suffolk and Norfolk Streets north of Delancey Street, have a greater number of fully residential and institutional uses, and thus have less pedestrian activity than the neighboring streets with greater amounts of ground-floor retail. Because of the age of the buildings, there are few loading docks or associated curb cuts in this portion of the study area, except those associated with recently constructed, larger-scale developments.

The portion of the study area south of Delancey Street and east of Essex Street (surrounding Sites 2–6) has a different visual character than the rest of the study area. In this area, large housing complexes on superblocks and surface parking lots surrounded by chain link fencing establish the visual character. These complexes are typically set back from the street line within a landscaped setting, and thus the streetwalls in this portion of the study area are less strong, particularly along Grand Street. The large housing complexes in this portion of the study area include the Seward Park Houses, four 21-story (187-foot-tall) brick buildings—each roughly 150 feet wide and 350 feet long—set on an angle in a landscaped campus on the three-block triangle bounded by Grand Street, Essex Street, and East Broadway. The large footprints of these buildings and their angled placement on the superblocks serve to make them particularly noticeable in the surrounding area (see View 30 of **Figure 8-17**). The portion of the Seward Park Extension NYCHA project on the block bounded by Essex, Norfolk, Broome, and Grand Streets (referred to as the Broome Seward Park Extension) is a 23-story (229-foot-tall) brown-brick tower with no setbacks. The remainder of the block is surrounded by a low brown brick wall, within which is a hardscaped private open space with one piece of play equipment (see View 31 of **Figure 8-18**). Other portions of the Seward Park Extension include a twin building on the block bounded by Broome, Ridge, Clinton, and Delancey Streets, and three 26-story (232-foot) brick buildings with roughly square footprints on the superblock bounded by Clinton, Pitt, Broome, and Grand Streets.

On the south side of Grand Street, some of the open areas between the Seward Park Houses are enclosed behind blue metal grid fencing. These open areas, and others within the Seward Park Houses complex include attractive lawns, gardens, and mature trees, as well as play equipment for residents (see View 32 of **Figure 8-18**). In addition to the various housing complexes, this portion of the study area includes several 1-story buildings along Grand Street, including a broad, low, modern 1-story retail building at the southwest corner of Clinton and Grand Streets



Suffolk Street, view south from Delancey Street 25



Orchard Street, view south from Broome Street 26

Photographs of Study Area  
Views 25 & 26  
**Figure 8-15**





Rivington Street, view west from Essex Street 27



Ludlow Street, view north from Rivington Street 28

Photographs of Study Area  
Views 27 & 28  
Figure 8-16



Lower East Side Preparatory School/Marta Valle School, view northwest from Rivington and Suffolk Streets **29**



Seward Park Houses, view west from Grand Street **30**

Photographs of Study Area  
Views 29 & 30  
**Figure 8-17**





North side of Grand Street, view west from Norfolk Street 31

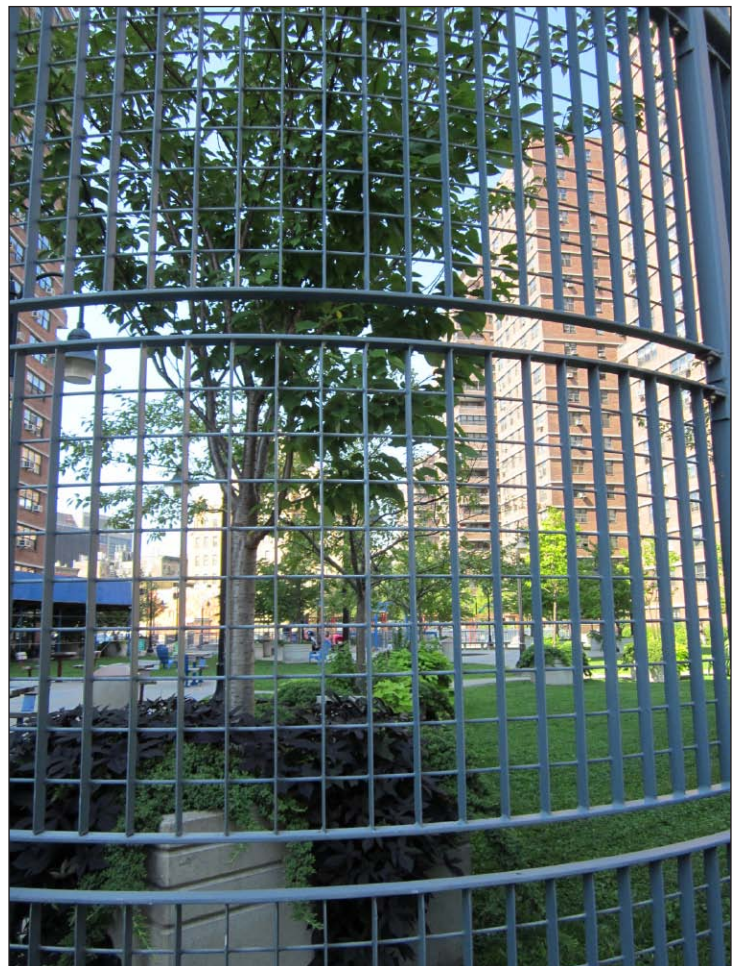

Seward Park Houses, private open space 32

Photographs of Development Sites  
Views 31 & 32  
Figure 8-18

that is part of the Seward Park Houses complex. The building's broad roof overhang provides shade and relief from the elements for shoppers and pedestrians (see View 33 of **Figure 8-19**).

The portions of the study area north of Delancey Street, and west of Ludlow Street south of Delancey Street, were recently rezoned to preserve their mainly low-scale existing character. These areas are densely developed, mainly with 4- to 6-story tenement buildings that are built to the street line and fully occupy their lots. Most of these buildings are still in residential use on the upper floors and have ground-floor retail. Some of the tenement buildings in this area retain their original features and are highly ornamented; others have experienced more alterations over the years, particularly at the ground floor (see View 26 of **Figure 8-15**).

Some of the modern insertion buildings within this area keep to the same 4- to 6-story scale. Higher-density residential and hotel development also is becoming more prevalent in this area, with a number of taller buildings currently under construction or recently completed. These include the 16-story (169-foot-tall) Blue Condo at 100 Norfolk. Because it is surrounded by lower-scale development, the Blue Condo building is visible throughout much of the study area. There is also a new glass and metal-clad, 21-story (195-foot-tall) hotel building at 107 Rivington Street, just west of Essex; an 18-story (226-foot-tall) School of Visual Arts (SVA) dorm at 101 Ludlow Street, the northwest corner of Ludlow and Delancey Streets; an 18-story mixed-use hotel/residential building at 180 Ludlow Street, the 16-story Allen Street Hotel at 139 Allen Street, the 24-story Hotel Indigo at 180 Orchard Street, and an 8-story Holiday Inn at 150 Delancey Street (see Views 27 and 28 of **Figure 8-16**). The juxtaposition of these new high-rise developments against the prevailing low-scale development north of Delancey Street is changing the visual character of this portion of the study area.

Other buildings in the study area include religious and educational facilities, firehouses, police precincts, post offices, libraries, and commercial buildings. The Lower East Side Preparatory School and the Marta Valle School, for example, share a bulky concrete- and brick-clad 4-story building on the block bounded by Stanton, Suffolk, Rivington, and Norfolk Streets. The concrete-paved play yard on the south side of the school block is surrounded by chain link fencing (see View 29 of **Figure 8-17**). Just south of the high school is a 5-story, L-plan, C.B.J. Snyder-designed brick school building with terra cotta ornament. This former P.S. 160 building, which currently houses the Clemente Soto Velez Educational and Cultural Center, is currently being restored and is covered with scaffolding and netting. Other large public schools in the study area include the Seward Park High School (described below); P.S. 20, Anna Silver School, a 3-story, utilitarian brick structure at 166 Essex Street between East Houston and Stanton Streets; and P.S. 142, Amalia Castro School, a 3-story circular brick structure occupying the entire block bounded by Rivington, Ridge, Delancey, and Attorney Streets.

### VISUAL RESOURCES

The *CEQR Technical Manual* defines a visual resource as “the connection from the public realm to significant natural or built features, including views of the waterfront, public parks, landmark structures or districts, otherwise distinct buildings or groups of buildings, or natural resources.”

#### PROJECT SITE

There are no visual resources located on the project site. While the Essex Market buildings on Sites 2, 8, 9, and 10 are known architectural resources, and the three buildings on Site 5 have been identified as potential architectural resources (see Chapter 7, “Historic and Cultural Resources”), these buildings are not particularly prominent or distinct in surrounding views. (Site 1 is located within the boundaries of the State and National Register-listed Lower East Side





Clinton Street, view south from Grand Street 33



View south on Essex Street from Stanton Street 34

Photographs of Study Area  
Views 33 & 34  
Figure 8-19

Historic District, but as noted above is occupied by a paved parking lot.) In general, views from and through Sites 1–6 are more expansive than from Sites 7–10 because of the lack, or lesser level, of development on Sites 1–6. Views looking south on Essex Street from sidewalks adjacent to Sites 7–10 include the 23-story Seward Park Extension tower and portions of the glass-clad Blue Condo building; views looking north end at Houston Street (see View 34 of **Figure 8-19**). Views from and through Sites 1–6 include the Williamsburg Bridge and the Blue Condo, as well as the various NYCHA housing developments described above and below (see View 35 of **Figure 8-20** and Views 3, 4, 6 of **Figures 8-4** and **8-5**, above).

#### *STUDY AREA*

North of Delancey Street, views to the north on most of the north-south streets terminate with the buildings along Houston Street, including 250 Houston Street, with its rooftop “Askew” clock and statue of Vladimir Lenin, and the Meltzer Tower NYCHA development, as well as new developments within the study area (see View 36 of **Figure 8-20** and View 28 of **Figure 8-16**, above). The play yards associated with the Lower East Side Preparatory School and other public schools noted above also allow wider views through adjacent portions of the study area.

Delancey, Grand, and Allen Streets, as the widest thoroughfares in the study area, also provide the most expansive view corridors. Views east along Delancey Street are of the Williamsburg Bridge, both the bridge approach and its Manhattan-side anchorage (see View 37 of **Figure 8-21**). Views from Delancey Street looking south are more expansive because of the general lack of development on Sites 1–6. From this location, the large-scale housing complexes described above can be seen, as well as other large-scale housing complexes located outside of the study area. From the south side of Delancey Street looking north, views include the Blue Condo. Views north along Allen Street and a portion of Essex Street include the top of the Chrysler Building (see View 38 of **Figure 8-21**). There are few items of note in views along Grand Street, excepting the twin corner towers of St. Mary’s R.C. Church. Views from Essex Street near Grand Street south include the top of the Manhattan-side anchorage of the Manhattan Bridge (see View 39 of **Figure 8-23**).

Views from Broome Street north through Sites 3, 4, 6 and a portion of 2 are of the Blue Condo on Norfolk Street, other tall buildings in the northern part of the study area, and the top of the Empire State Building in the far distance. Views to the northeast from this area are of the Baruch and Gompers public housing complexes on the north side of Delancey Street, just east of the study area (see View 40 of **Figure 8-22**). Views east along Broome Street end with the 11-story brick-clad Lejb and Golda Orenstein Building on the superblock that also contains the historic Bialystoker Synagogue facing onto Abraham Place, which is not visible in the eastward views from Broome Street. South of Grand Street, Clinton Street curves to the east, closing off that view corridor with the buildings along East Broadway; views north on Clinton Street include the top of the Empire State Building. Views through Site 6 include the masonry entrance to the Williamsburg Bridge (see View 41 of **Figure 8-23**). Views south on Norfolk Street are of the Seward Park Houses. Views north and south along Ridge Street are of the viaduct carrying the Williamsburg Bridge approach above Delancey Street (see View 42 of **Figure 8-23**).

Views to the project site are also available to pedestrians, bicyclists, and drivers from the Williamsburg Bridge itself. From this location, viewers get a strong sense of how the visual character of the study area differs north and south of Delancey Street (see Views 43 and 44 of **Figure 8-24**). There are no notable visual resources in these views, other than the bridge itself.





View east on Delancey Street, from Suffolk Street 35



View north on Suffolk Street from Stanton Street 36



View east on Delancey Street from Orchard Street 37



View north on Allen Street from Grand Street 38





View southeast from Essex Street near Grand Street 39



View northeast from Broome and Norfolk Streets 40

Photographs of Study Area  
Views 39 & 40  
Figure 8-22



View north through Site 6, from Broome Street 41



View north on Ridge Street, from Broome Street 42

Photographs of Study Area  
Views 41 & 42  
**Figure 8-23**





View west to project area south of Delancey Street, 43  
from Williamsburg Bridge



View west to project area north of Delancey Street, 44  
from Williamsburg Bridge

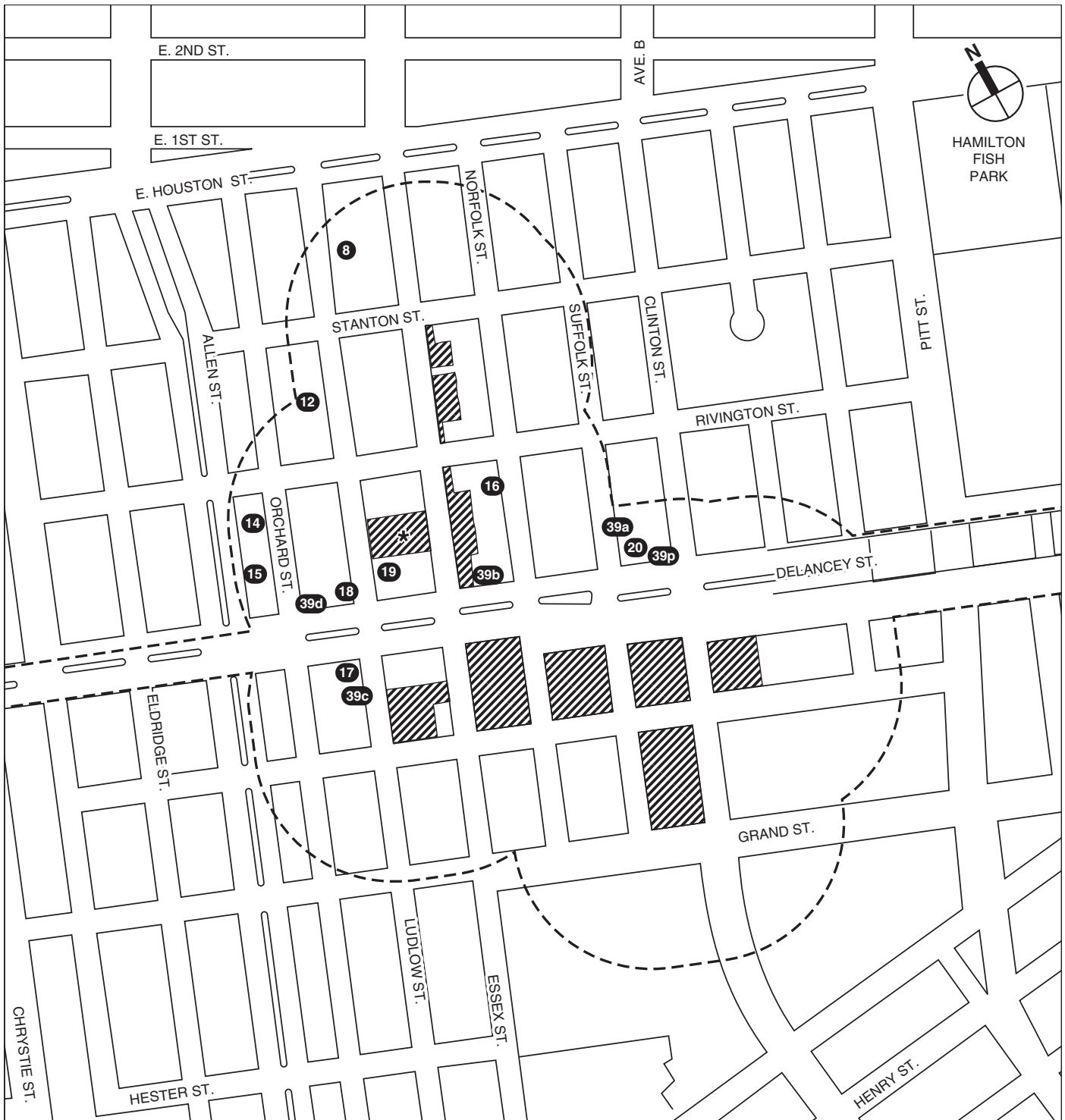

-  Proposed Development Sites
- \* Site 7 Would Not Be Redeveloped Under the Proposed Actions
-  Study Area Boundary (400-Foot Perimeter)
-  No Action Projects  
(see Chapter 2, "Land Use, Zoning and Public Policy" for list of No Action Projects)







 *Proposed Maximum Envelopes*

FOR ILLUSTRATIVE PURPOSES ONLY

Illustrative Three-Dimensional Computer Model of Maximum Zoning Envelopes  
View Southwest  
**Figure 8-26**



## **E. THE FUTURE WITHOUT THE PROPOSED ACTIONS**

In the future without the proposed actions, existing conditions on the project site would not change. Most of the project site would continue to be largely vacant and underutilized; however, the municipal parking garage on Site 7 will be refurbished. The current façade of the garage, which consists of deteriorated concrete panels, will be replaced with a weave of steel cables that will improve the appearance and thus the pedestrian experience of this facility.

### **EFFECTS OF OTHER FUTURE PROJECTS**

Fourteen development projects are anticipated to be constructed within the study area independent of the proposed project (see **Figure 8-25**). These projects include a commercial addition to existing buildings at 95 Delancey Street/101 Ludlow Street (a 19-story building); new hotel buildings at 150 Delancey Street (8 stories tall), 180 Ludlow Street, and 139 Orchard Street (16 stories tall); new residential buildings at 91 Ludlow Street, 80 Clinton Street, 115 Norfolk Street, and 88, 100, 124, and 156 Delancey Street (all projected to be approximately 120 feet tall or less); and new mixed-use buildings at 145 Ludlow Street (6 stories) and 119 Orchard Street (10 stories). Just outside of the study area, a 26-story mixed-use (hotel and residential) building is under construction at 180 Orchard Street, and a 16-story hotel is under construction at 139 Allen Street. These projects will change the urban design and visual character of the study area by continuing an existing trend of new residential, hotel, and mixed-use development and adding to the area's mix of low-rise and high-rise structures, making the neighborhood more densely developed.

## **F. PROBABLE IMPACTS OF THE PROPOSED ACTIONS**

### **URBAN DESIGN**

#### *PROJECT SITE*

As set forth in Chapter 1, "Project Description," the proposed actions include:

- Disposition of Sites 1-6 and 8-10 by the City of New York for the purpose of subsequent development;
- Designation of Sites 1-6 and 8-10 as an Urban Development Action Area Project;
- Acquisition of a portion of Site 2 for the purposes of the relocated Essex Street Market;
- A zoning map amendment for a C2-6 commercial overlay on Sites 3-6;
- A special permit for a LSGD, applicable to Sites 1–6 (see **Figure 8-26**), to achieve a superior site plan;
- Special permits and zoning text amendments to allow certain use groups and the shifting of commercial FAR from the C6 district to the C2 district, eliminate the planting strip requirement in the proposed sidewalk widenings, and waive certain location of use regulations within the proposed LSGD;
- Special permits related to public parking garages;
- An authorization for the modification of signage regulations to permit C6-1 signage along certain streets, and a zoning text amendment to allow the signage waiver;
- Mapping of the demapped sections of Suffolk Street between Grand and Delancey Streets and Broome Street between Norfolk and Clinton Streets as new streets through the project site; and

- Demapping of sections of Delancey Street between Norfolk and Clinton Streets and of Clinton Street between Delancey and Grand Streets that were previously mapped to widen Delancey and Clinton Streets, thereby aligning the mapped street with the existing built street condition.

Under the reasonable worst-case development scenario (RWCDS) developed for the proposed actions, it is assumed that the proposed actions would result in the full redevelopment of Sites 1–6 and 8–10. The existing buildings on Sites 2, 5, 8, 9, and 10 would be demolished, the existing parking uses on sites 1, 3, 4, and 6 would be removed, and all of the sites except Site 7 would be redeveloped with new mixed-use buildings of varying height and bulk. The RWCDS assumes the development on the proposed sites would total approximately 951,000 square feet (900 units) of residential uses; up to 632,300 gross square feet (gsf) of commercial space; approximately 114,000 gsf of community facility or cultural uses; up to 500 parking spaces in below-grade space; and approximately 10,000 square feet of new publicly accessible open space on Site 5. The existing Essex Street Market would be relocated from Site 9 to a new, larger facility of approximately 29,000 gsf.

The urban design concept for the LSGD is to combine the defining characteristics of the northern and southern portions of the study area—the strong streetwalls north of Delancey Street, and the light and air provided by the “tower in the park”-style developments south of Delancey Street—using a tower on base approach to provide a transition between these two distinct areas. The illustrative massing prepared for the RWCDS anticipates higher density along Delancey and Essex Streets, with lesser density and lower heights on the portions of the sites fronting other, narrower streets. The illustrative RWCDS massing contemplates building base heights of between 60 and 85 feet (six to eight stories), with varying heights above.

**Table 8-2** provides the assumed RWCDS and maximum heights for the development on each site. **Figure 8-26** shows an illustration of the maximum zoning envelopes on the nine development sites; **Figures 8-27a through 8-27f** show potential massings for the RWCDS on Sites 1-6; and **Figures 8-28** and **8-29** provide illustrative renderings of some of the potential massings for the RWCDS.

The actual development on each site would be within the limits of the maximum zoning envelope according to LSGD rules, and the design would be determined through responses to Request(s) for Proposals. For the maximum zoning envelope, Sites 2 and 4 could have new towers of up to 285 feet and 260 feet, respectively (315 and 290 feet, respectively, to the top of mechanical bulkheads, or up to approximately 24 stories), and the new developments on Sites 1, 3, 5, and 6 could have building heights of up to 160 feet (190 feet to the top of mechanical bulkheads, or up to approximately 14 stories). The development projected to occur on Sites 8, 9, and 10 (80 feet tall on Essex Street, 120 feet tall along Delancey Street) would be consistent with the massing requirements and maximum heights allowable under existing zoning. The upper portions of all buildings would be set back at least 10 feet from wide streets and 15 feet from narrow streets, per zoning, except along Clinton Street where 10-foot setbacks would be permissible. As shown on **Figure 8-26**, it is assumed that the tallest portions of the new development would be oriented along Delancey and/or Clinton Streets. It is also assumed that a portion of the interior of the lots could be reserved for landscaped or private open space. The projected new buildings would have ground-floor retail and residential entrances on multiple sides to create pedestrian activity surrounding the sites as well as to provide necessary access.

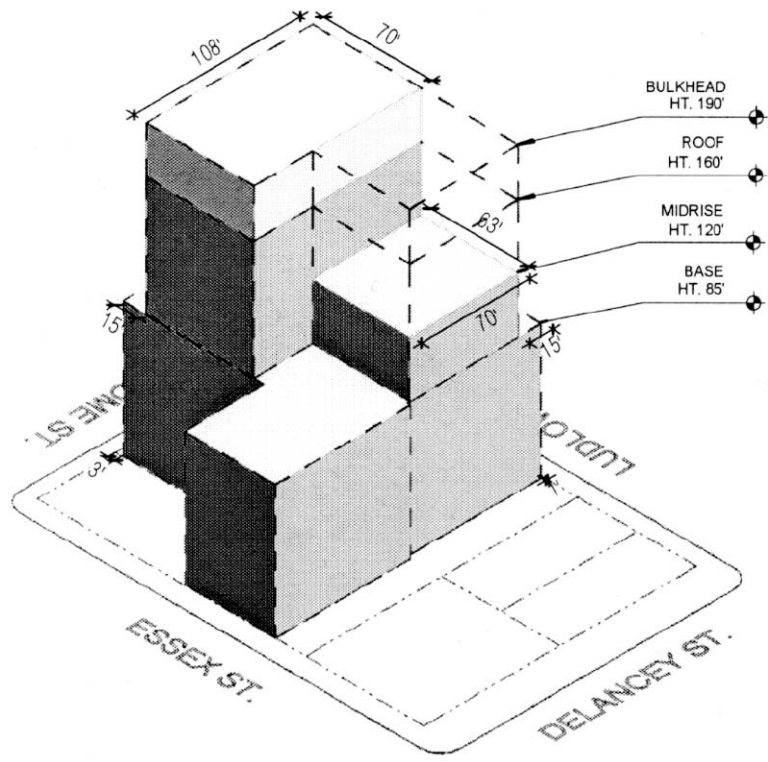
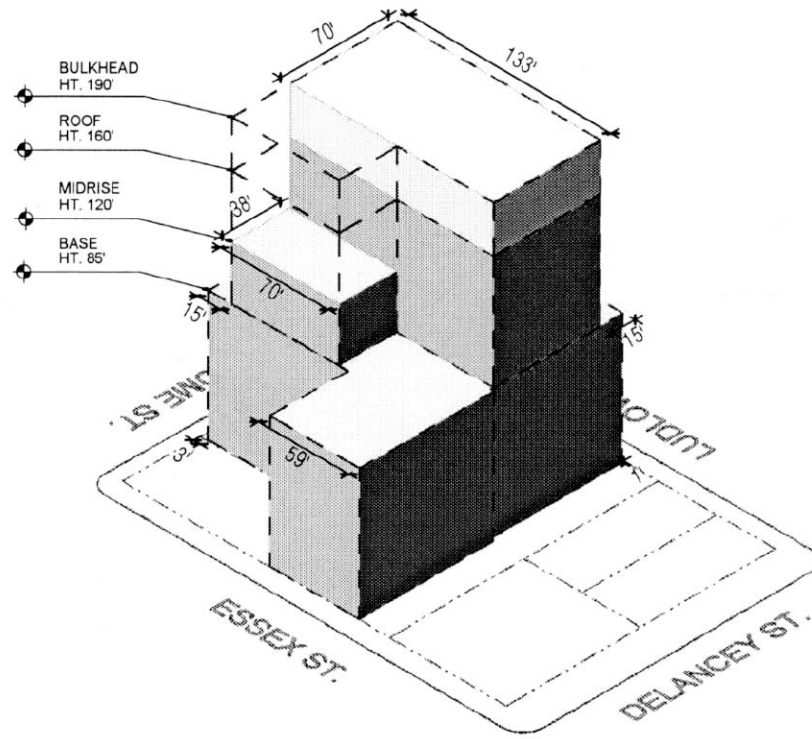

FOR ILLUSTRATIVE PURPOSES ONLY

Illustrative Large Scale General Development Massings  
Site 1 - View from Northeast



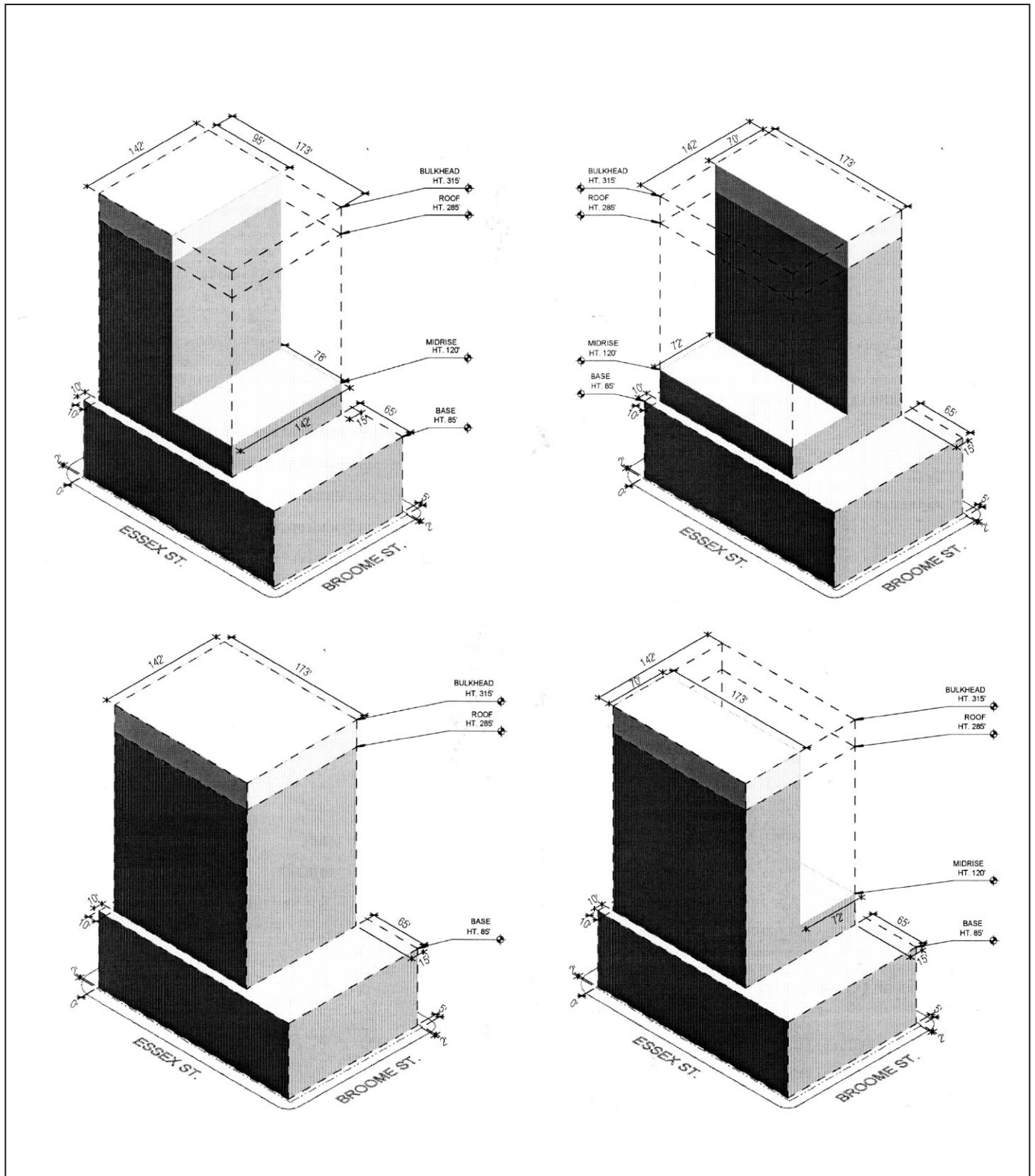

FOR ILLUSTRATIVE PURPOSES ONLY

Illustrative Large Scale General Development Massings  
Site 2 - View from Southwest

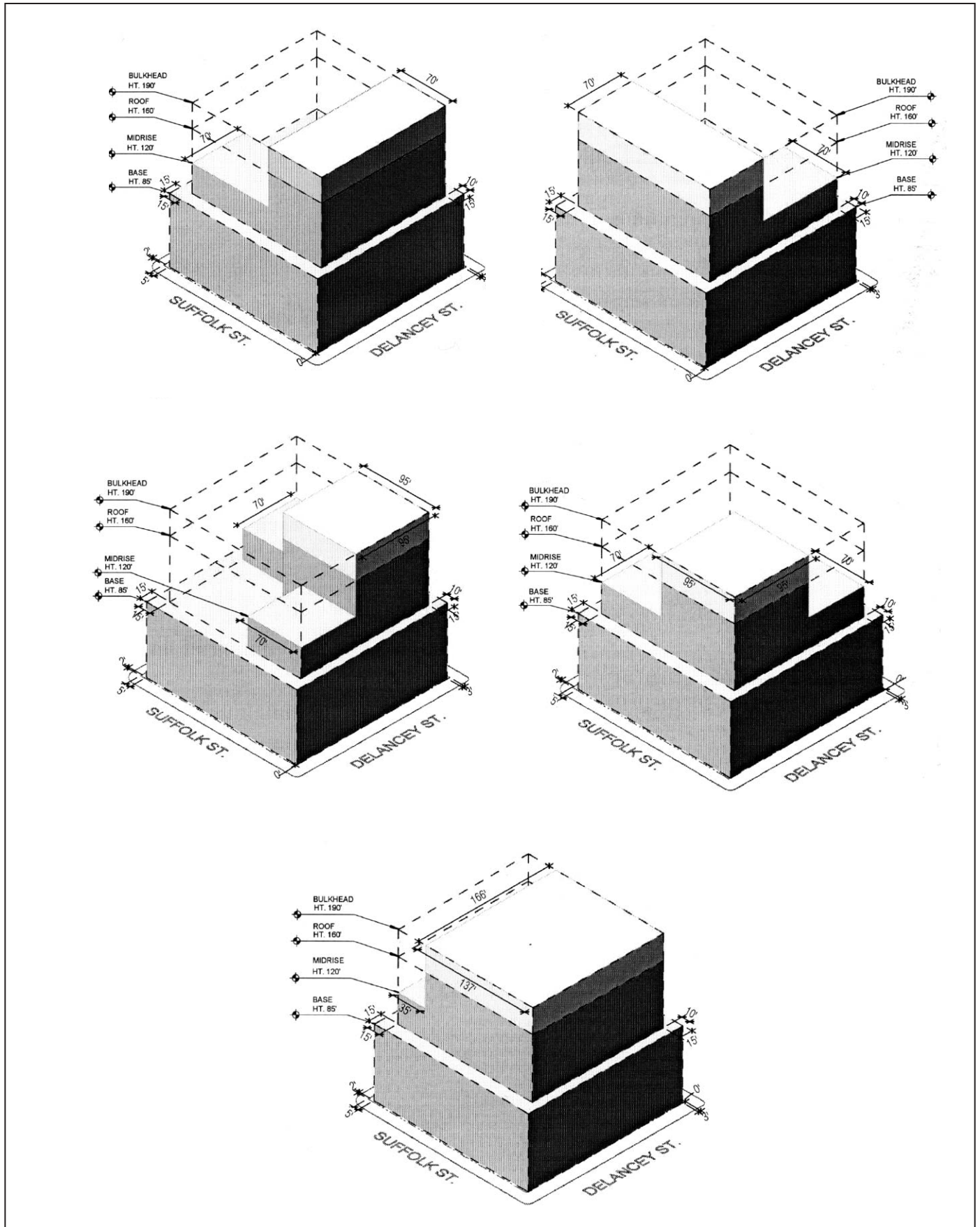

FOR ILLUSTRATIVE PURPOSES ONLY

Illustrative Large Scale General Development Massings  
Site 3 - View from Northeast



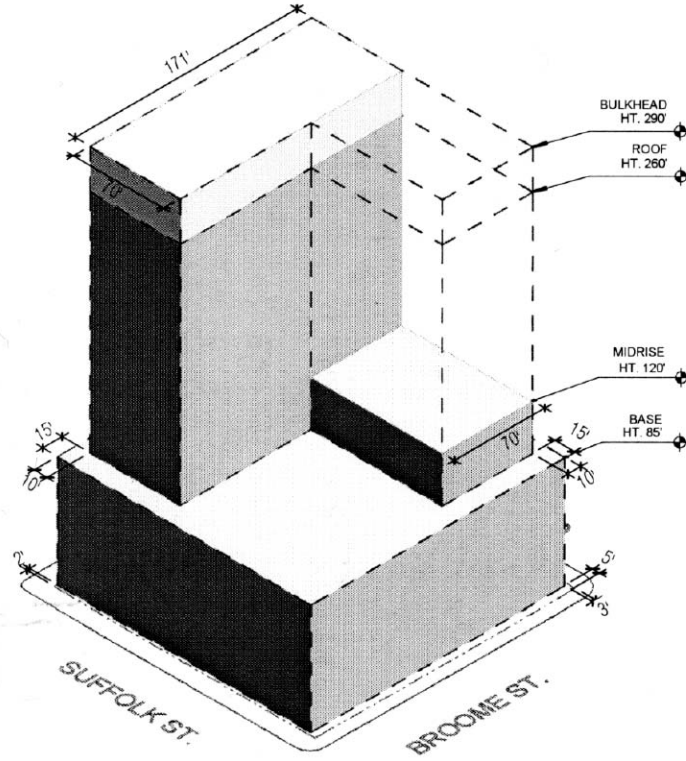
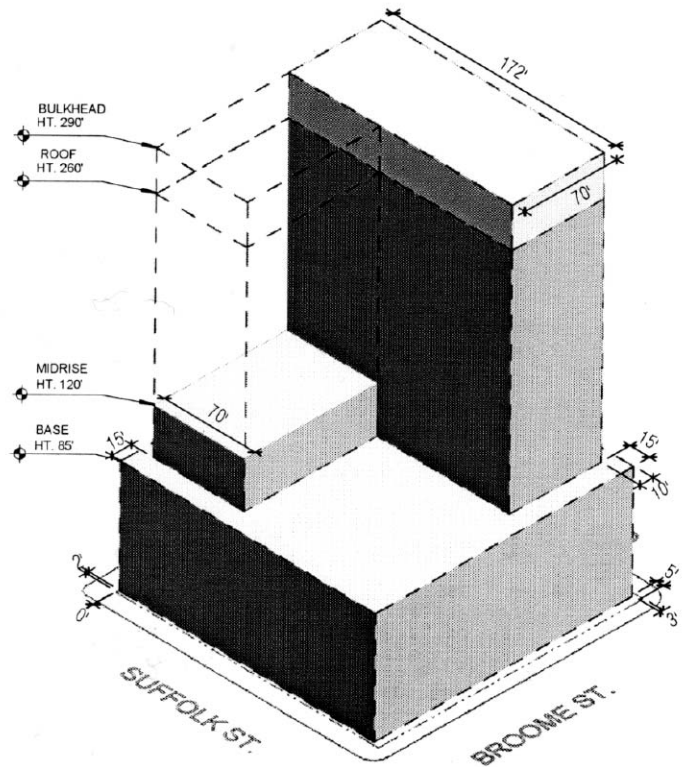

FOR ILLUSTRATIVE PURPOSES ONLY

Illustrative Large Scale General Development Massings  
Site 4 - View from Southwest

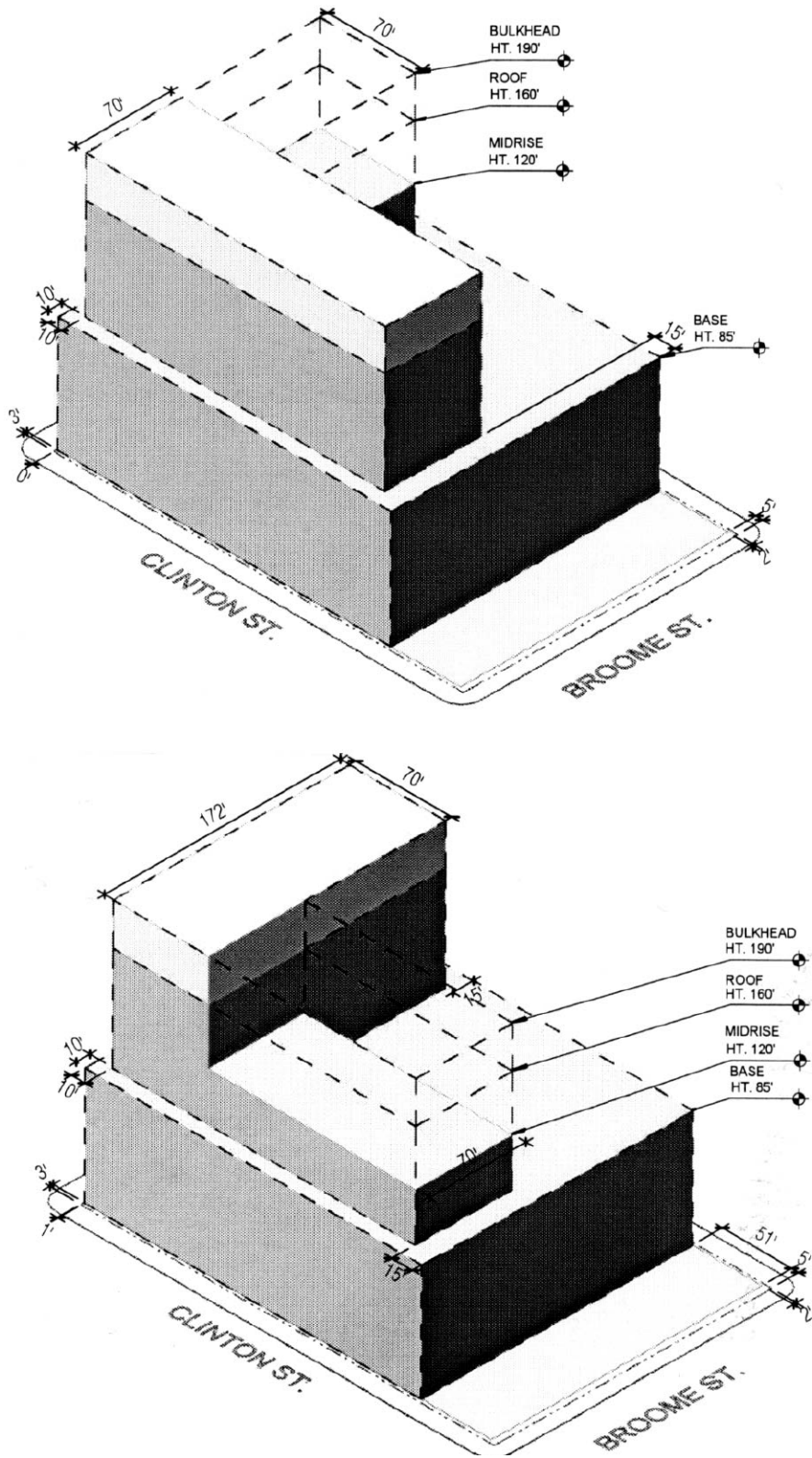

FOR ILLUSTRATIVE PURPOSES ONLY

Illustrative Large Scale General Development Massings  
Site 5 - View from Northeast



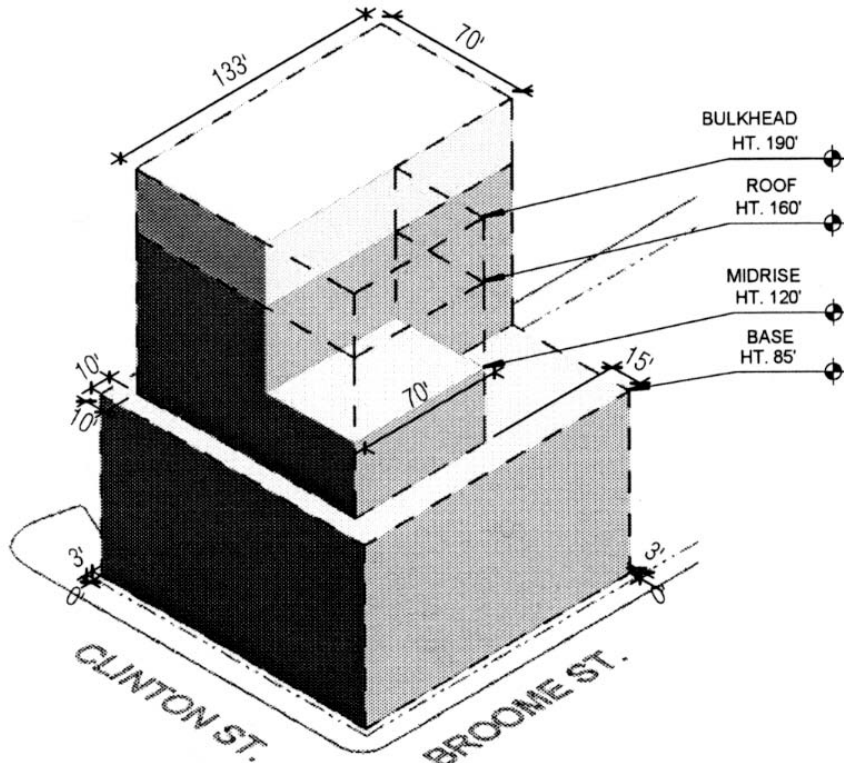
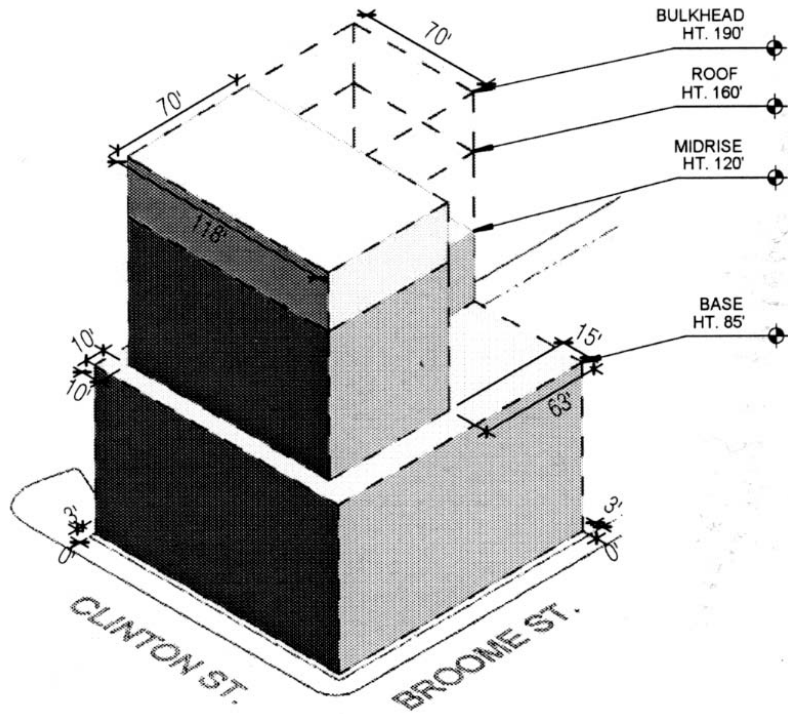

FOR ILLUSTRATIVE PURPOSES ONLY

Illustrative Large Scale General Development Massings  
Site 6 - View from Southwest



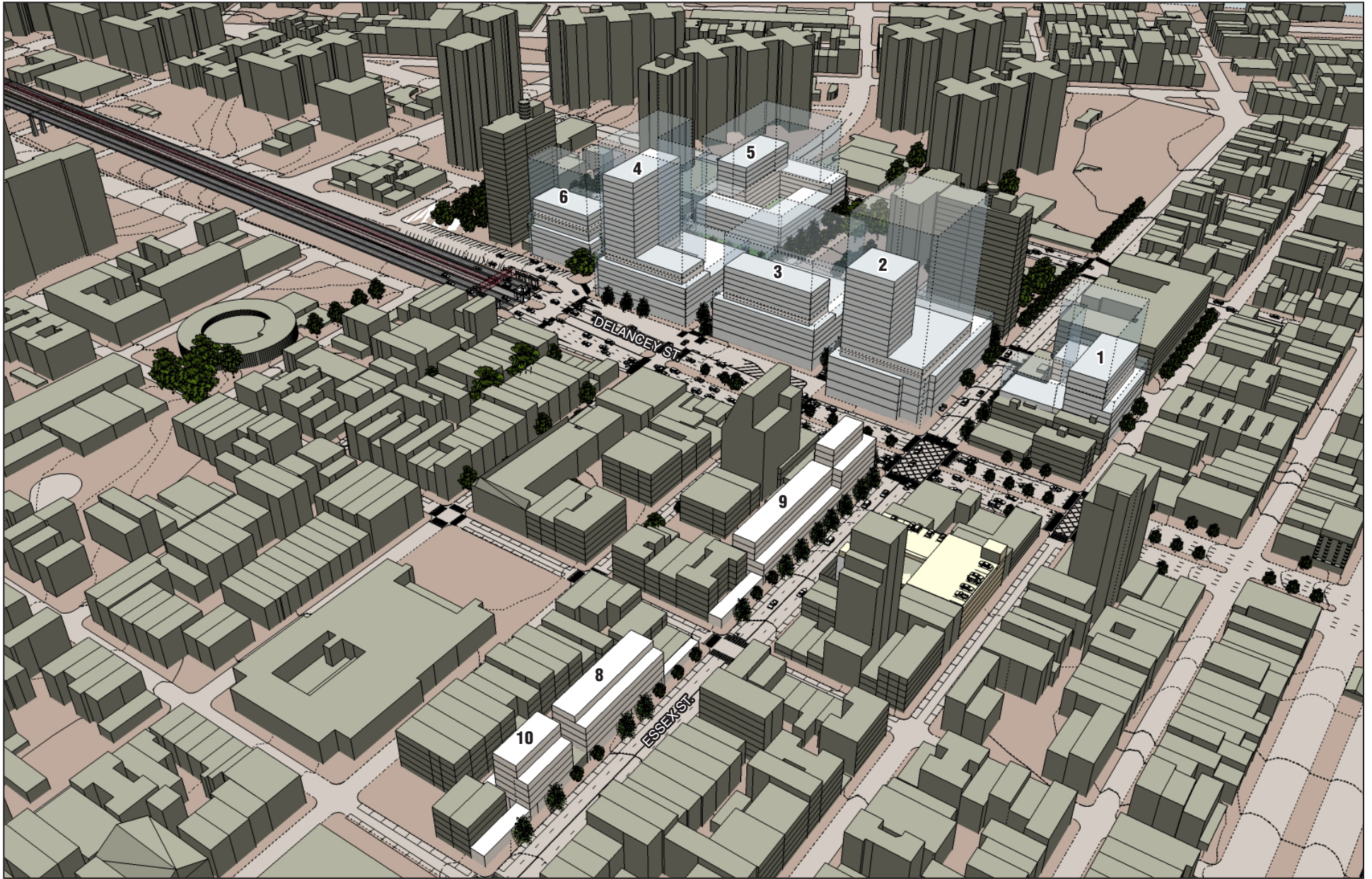

FOR ILLUSTRATIVE PURPOSES ONLY

Illustrative Rendering with Maximum Building Envelopes and  
RWCDs Massing - View South  
**Figure 8-28**





FOR ILLUSTRATIVE PURPOSES ONLY

Illustrative Rendering with Maximum Building Envelopes and  
RWCDs Massing - View Northeast

**Figure 8-29**



**Table 8-2:  
Preliminary Massing Scenario**

Site No.	Maximum Zoning Envelope		RWCDS	
	Maximum Floors	Total Height (Approx., to Mechanical Bulkheads)	Assumed No. Floors	Height (Not Including Mechanical Bulkheads)
1	14	190	10	120
2	24	315	20	231
3	14	190	12	140
4	24	290	22	240
5	14	190	12	130
6	14	190	10	110
7	No change			
8	Existing zoning compliant	80 (Existing zoning compliant)	6	70
9	Existing zoning compliant	80 on Essex, 120 on Delancey (Existing zoning compliant)	9	100
10	Existing zoning compliant	80 (Existing zoning compliant)	7	80

The projected development also would maximize street-level uses such as retail that support pedestrian activity throughout the development. A publicly accessible open space of approximately 10,000 square feet with a mix of active and/or passive recreation uses also would be incorporated into the development on Site 5. The proposed development is also anticipated to include new street trees.

In comparison to the maximum zoning envelope, the RWCDS assumes that Sites 2 and 4 would have new towers of up to 231 and 240 feet, respectively (up to 20 and 22 stories, respectively) and the new developments on Sites 1, 3, 5, and 6 are assumed to have building heights of between 110 and 140 feet (up to 12 stories). The developments projected to occur on Sites 8, 9, and 10 would be 70, 100 (only on Delancey Street), and 80 feet tall, respectively. As illustrated on **Figures 8-27a through 8-27f, 8-28, and 8-29**, the RWCDS assumes that the towers on Sites 2 and 4 would be generally oriented toward the wider, more active Delancey Street corridor. The proposed actions are intended to create variety in tower orientation, avoiding towers in adjacent blocks on Delancey Street from orienting in the same north-south or east-west alignment. The upper portions of all buildings would be set back as described above. In comparison to the maximum zoning envelope, the RWCDS illustrative massings also show that the upper portions of the buildings are allowed to have both shorter and taller tower elements, which would add to the individual distinctiveness of each site. In general, the RWCDS assumes that the buildings to be constructed on Sites 1-6 would be less tall and more varied in the arrangement of their bulk than is illustrated by the maximum zoning envelope.

In the portion of the LSGD that is within a C2 zoning district, the sign regulations of a C6-1 district may be made applicable through CPC authorization. The C6-1 district signage equivalent would apply to the LSGD frontages on Delancey and Grand Streets only. The CPC also may modify the provisions of Zoning Resolution Section 32-68 (Permitted Signs on Residential or Mixed Buildings). In order to grant such authorizations, CPC shall find that such modifications

are consistent with the location of commercial uses permitted within the LSGC and will not adversely affect residential uses in adjoining residential districts. The changes would allow for the maximum surface area of non-illuminated and illuminated signs to be up to 500 square feet on each street frontage, rather than 150 feet and 50 feet, respectively. In addition, the height of signs accessory to non-residential uses would be permitted up to 40 feet above curb level, rather than up to 25 feet above curb level for commercial buildings or below the level of the finished floor of the third story for residential buildings.

Compared to the future without the proposed actions, in the future with the proposed actions the visual appearance and thus the pedestrian experience of the development sites would change considerably; however, this change would not meet the *CEQR Technical Manual* threshold for a significant adverse urban design impact, in that it would not alter the arrangement, appearance, or functionality of the sites such that the alteration would negatively affect a pedestrian's experience of the area. Rather, instead of undeveloped and under-developed sites surrounded by chain link fencing, the pedestrian would experience new buildings with active ground-floor uses, including retail (see **Figures 8-30** and **8-31**). The gaps in the streetscape of the neighborhood south of Delancey Street would be filled with this new development. New street trees would shade as well as visually enhance the experience of walking around the project sites. Greater levels of pedestrian activity generated by the proposed uses on the sites would be self-reinforcing, making the project area more inviting and appealing to visit. As with the existing buildings on Sites 8, 9, and 10, the projected development on these sites would be built to the lot line, thus maintaining streetwalls where they currently exist. The new development on Sites 1-6 would be pulled back slightly from the lot line on two or more sides to accommodate wider sidewalks; therefore, the streetwalls on these frontages would be approximately the same, but one to five feet deeper, depending on the site and frontage. New streetwalls would be created by the buildings to be developed on Sites 1, 3, 4, and 6, thus strengthening the visual character of these sites and connecting them to the surrounding built environment, and the streetwalls created by existing buildings on other sites would be maintained with the new development. The new publicly accessible open space on Site 5 would bring passive and/or active recreational opportunities to an area where these are not widely available to the general public. (While there are more public open spaces in the larger neighborhood, including Seward Park and Sara D. Roosevelt Park, as noted above the public open spaces within the study area are mainly playgrounds associated with public schools and public and privately-owned housing complexes.) The proposed mapping and demapping actions would make the mapped street pattern consistent with the pedestrian's current experience of those areas. The potential changes in signage regulations would provide for larger and higher-placed signage than is currently allowed on Delancey, Grand, and Essex Streets; however, as noted above these are among the main pedestrian and vehicular thoroughfares in the study area and thus are more appropriate locations for larger signage than other, more narrow or residential streets. In addition, Delancey Street already includes large directional signage on gantries.

The buildings on the project sites would generally be anticipated to fully occupy their lots, and thus would be consistent with the full lot coverage of existing buildings on Sites 8-10 (as well as the structure on Site 7, which will remain). Exceptions to this pattern would be the sidewalk setback easements noted above for Sites 1 through 6, and the new open space to be developed on Site 5. Furthermore, the assumed building base height (6-8 stories) reflects the scale of existing buildings in the northern portion of the surrounding area, which as noted above are predominantly tenements. Although the towers on the development sites would be taller than what currently exists on the sites, because Sites 1-6 are mostly not developed with buildings,



Existing/No Action Condition



FOR ILLUSTRATIVE PURPOSES ONLY

With Action Condition

Illustrative Rendering of Broome Street  
View West from Clinton Street

**Figure 8-30**





Existing/No Action Condition



FOR ILLUSTRATIVE PURPOSES ONLY

With Action Condition

Illustrative Rendering of Proposed Development  
Aerial View South  
**Figure 8-31**

## **Seward Park Mixed-Use Development Project**

---

they would be generally consistent with other large-scale buildings within the surrounding area. As described above, the buildings in the southern portion of the study area are generally towers on superblocks, set back from the street line within a landscaped setting. The LSGD allows for transfer of floor area and variations in the arrangement of bulk across Sites 1-6; however, the overall height maximums established within the LSGD would be maintained. Furthermore, the RWCDS assumes that the buildings to be constructed on Sites 1-6 would be less tall and more varied in the arrangement of their bulk than is illustrated by the maximum zoning envelope. The ground floors of the new buildings within the LSGD would be required to have 70 percent glazing, with a minimum of 50 percent transparency and a maximum of 20 percent translucency, to help activate the ground-floor appearance of these buildings. The uses proposed for the new buildings would be consistent with land uses found in the surrounding area.

Overall, the proposed actions would enhance the pedestrian's experience of the development sites by replacing underutilized buildings and surface parking lots with new active, mixed-use development.

### *STUDY AREA*

Compared to the future without the proposed actions, in the future with the proposed actions the visual appearance of the development sites—and thus the pedestrian's experience of the study area—would change considerably. The gaps in the streetscape of the neighborhood south of Delancey Street would be filled with new, active development. New street trees would shade as well as visually enhance the experience of walking around the project sites. Greater levels of pedestrian activity generated by the proposed uses on the sites—particularly ground-floor retail uses—would be self-reinforcing, making the project area more inviting and appealing to visit. New streetwalls would be created where they do not currently exist.

The proposed actions would preserve existing streets, including those that had been demapped in the 1960s but were never taken out of functional use. In terms of building orientation and access, the projected new buildings would have retail and residential entrances on multiple sides to create pedestrian activity surrounding the sites, provide necessary access, and integrate with the existing neighborhood.

As noted above, for the maximum zoning envelope, Sites 2 and 4 are assumed to have new towers of up to 285 and 260 feet, respectively (315 and 290 feet respectively to the top of mechanical bulkheads, approximately 24 stories), and the RWCDS assumes that these sites would have new towers of up to 231 and 240 feet, respectively (up to 20 and 22 stories, respectively). The new developments on Sites 1, 3, 5, and 6 are assumed for the maximum zoning envelope to have building heights of up to 160 feet (190 feet to the top of mechanical bulkheads, up to approximately 14 stories), and up to 140 feet (approximately 12 stories) for the RWCDS. The height of the anticipated towers on Sites 2 and 4 would be compatible with the larger existing buildings in the area, such as the various Seward Park Extension towers, which range in height from 229 to 232 feet. The height of the anticipated towers on Sites 1, 3, 5, and 6 would be more consistent with that of the Seward Park Houses (at approximately 187 feet) to the south and the 169-foot-tall Blue Condo and the 195-foot-tall Hotel on Rivington to the north. The setbacks of the anticipated towers would permit access to light and air. The lot coverage of the new buildings on Sites 1–6 would be greater than that of other large-scale developments south of Delancey Street, which are mainly set within large, landscaped sites, and would be more consistent with the lot coverage of the existing Essex Street Market buildings, tenements, and other lower-scale buildings in the study area. Due to the greater lot coverage on these sites, the overall bulk of the new buildings may appear larger than that of the various existing larger-scale



buildings noted above, even though the density is consistent with the surrounding context. The proposed actions would bring a greater level of active ground-floor uses to the portion of the study area south of Delancey Street and east of Essex Street, where the existing large housing developments currently do not provide many such uses. The proposed mixture of uses would be consistent with existing study area uses, however.

In summary, the proposed actions would change the urban design and visual character of the study area, but would improve the pedestrian experience by activating currently underdeveloped and under-utilized sites. This change would be consistent with the existing trends of new residential, hotel, and mixed-use development, making the neighborhood more densely developed.

## **VISUAL RESOURCES**

### *PROJECT SITE*

As noted above, there are no visual resources located on the project site. With the proposed actions, pedestrian-level views would no longer be available through the currently undeveloped portions of Sites 1–6; however, these through-site views do not currently provide views to any visual resources except the Williamsburg Bridge, and views of the Williamsburg Bridge would remain from Delancey Street adjacent to Sites 2–4 and 6, as well as other locations within the study area. Pedestrian-level views would still be available along sidewalks adjacent to Sites 1–6, and views north and south on Essex Street from sidewalks adjacent to Sites 7–10 also would remain available in the future with the proposed actions.

### *STUDY AREA*

In the future with the proposed actions, pedestrian-level views in the study area would include the more dense development anticipated on Sites 1–6 and 8–10 (see **Figure 8-30**). Since this development would be contained within existing blocks, existing view corridors along study area streets would not be obstructed. Delancey, Grand, and Allen Streets would continue to provide the most expansive view corridors, and views east along Delancey Street would continue to include the Williamsburg Bridge approach and its Manhattan-side anchorage. The context of these views would change notably with the new development—particularly the development anticipated on Sites 1–6—but this change would not be expected to be adverse (see **Figure 8-31**). Rather, the Delancey Street view corridor could be enhanced, as it could become more focused on the elements of the Williamsburg Bridge by the new development along the street, which would better frame these views.

Other than Delancey Street, views along Essex, Broome, and, to a lesser extent, Grand Streets would be most altered with the proposed actions. The change would be less notable on Essex Street north of Delancey Street, as the development projected for Sites 8, 9, and 10 would be consistent with the massing requirements and maximum heights allowable under the recently established contextual zoning. South of Delancey Street, views along these streets would no longer be as expansive, and they would be framed by new buildings, rather than fenced parking. The new buildings would be anticipated to improve the visual character of these sites, and thus the character of the view corridors, compared to the future without the proposed actions. The Blue Condo building and large-scale housing complexes in the surrounding area would be less visible from these vantage points; however, the Blue Condo and other tall, modern developments north of Delancey Street still would be visible in many other study area views, rising above the lower-scale development in this portion of the study area. Views along Grand Street would now include the new development on Site 5, which—at approximately 180 feet tall—would be

## **Seward Park Mixed-Use Development Project**

---

similar to the 187-foot-tall Seward Park Houses on the south side of the street. Views along Allen Street are not anticipated to be affected by the proposed actions. Views of the top of the Empire State Building from Clinton Street near East Broadway would likely no longer be available because of the development on Sites 1–5; however, these views are not prominent, and the Empire State Building would continue to be visible from other locations within and outside of the study area.

From the Williamsburg Bridge, views to the development sites north of Delancey Street would not be notably different with the proposed actions compared to existing conditions, since these sites are not currently visible from this location and would be developed with smaller-scale buildings. Views to the development sites south of Delancey Street, however, would be notably altered. The increased scale, both in terms of bulk and height, of the new buildings in this portion of the project area would be a significant change from the existing appearance and character of these sites. In many cases, the sites would go from hosting no buildings, to being fully occupied by tall, bulky structures. While significant, this change is not anticipated to be adverse. The change in views would not obstruct any visual resources, and views from this location are transitory.

Overall, while the proposed actions would result in substantial urban design changes, it would not have any significant adverse impacts related to urban design and visual resources. \*