

THE NEW YORK CITY LANDMARKS PRESERVATION COMMISSION



RULES

New York City Landmarks Preservation Commission
One Centre St. , 9th Fl. North
New York, NY 10007

(212) 669-7700

TITLE 63

This booklet contains the rules of the Landmarks Preservation Commission which can be referred to in Title 63 of Rules of the City of New York. In the event of any discrepancy between the rules as printed here and as they appear in Title 63, the text in title 63 should govern

November 1998
March 2000
Updated: July 2003



Michael R. Bloomberg, Mayor

Robert B. Tierney, Chair

Pablo E. Vengoechea, Vice-Chair

Joan Gerner

Roberta Brandes Gratz

Meredith J. Kane

Christopher Moore

Richard M. Olcott

Sherida E. Paulsen

Rev. Thomas F. Pike

Jan Hird Pokorny

Vicki Match Suna

TABLE OF CONTENTS

CHAPTER 1: PRACTICE AND PROCEDURE PUBLIC HEARINGS AND MEETINGS OF THE COMMISSION	1-1
1-01 QUORUM.	1-1
1-02 CALENDARING.	1-1
1-03 WITHDRAWING AND LAYING OVER CERTIFICATE OF APPROPRIATENESS ITEMS.	1-1
1-04 FINAL ACTIONS.	1-2
1-05 SUBMISSIONS TO THE RECORD.	1-2
CHAPTER 2: ALTERATION OF LANDMARK AND HISTORIC DISTRICT BUILDINGS	2-1
SUBCHAPTER A: APPLICATION PROCEDURE	2-1
2-01 APPLICATION SIGNATURES NECESSARY FOR WORK PERMITS.	2-1
2-02 MASTER PLANS AND AUTHORIZATIONS TO PROCEED.	2-1
2-03 PROCESS FOR COMPLETING APPLICATION: STAFF WITHDRAWAL OF THE APPLICATION.	2-2
2-04 NOTICES OF VIOLATION - NEW APPLICATIONS.	2-3
SUBCHAPTER B: SPECIFIC ALTERATIONS	2-5
2-11 INSTALLATION OF HEATING, VENTILATING AND AIR CONDITIONING EQUIPMENT.	2-5
2-12 RULES FOR INSTALLATION OF AWNINGS	2-11
2-13 REMOVAL OF FIRE ESCAPES.	2-16
2-14 SANDSTONE RESTORATION AND REPLACEMENT.	2-17
2-15 NEW WINDOW OPENINGS.	2-17
2-16 REAR YARD ADDITIONS OR ENLARGEMENTS.	2-18
2-17 RESTORATION OF A BUILDING AND BUILDING FACADE FEATURES.	2-19
2-18 TEMPORARY INSTALLATIONS.	2-20
2-19 PROPOSED CONSTRUCTION OF ROOFTOP ADDITIONS	2-21
.....	2-21
ROOFTOP ADDITIONS: SUPPLEMENTARY INSTRUCTIONS FOR FILING	2-25
2-20 BRACKET SIGNS IN THE TRIBECA EAST, TRIBECA WEST, TRIBECA NORTH, TRIBECA SOUTH, SOHO CAST-IRON, NOHO, AND LADIES' MILE HISTORIC DISTRICTS.	2-26
SUBCHAPTER C: EXPEDITED REVIEW OF CERTAIN APPLICATIONS FOR CERTIFICATES OF NO EFFECT	2-29
2-31 DEFINITIONS.	2-29
2-32 EXPEDITED REVIEW PROCEDURES	2-30
2-33 EFFECT OF FAILURE TO MEET CONDITIONS FOR AN EXPEDITED	

REVIEW.	2-31
2-34 REMEDIES FOR FALSE STATEMENTS AND PROCEDURES FOR ACTION.	2-32
2-35 MISCELLANEOUS	2-33
APPENDIX A: RESOURCES FOR HISTORIC PHOTOGRAPHS & DRAWINGS	2-34
CHAPTER 3: REPAIR AND REPLACEMENT OF WINDOWS IN LANDMARK AND HISTORIC DISTRICT BUILDINGS (WINDOW GUIDELINES)	3-1
3-01 INTRODUCTION.	3-1
3-02 REPAIRS, REHABILITATION AND RESTORATION.	3-2
3-03 STORM WINDOWS.	3-2
3-04 REPLACEMENT OF SASH AND FRAMES.	3-3
3-05 MASTER PLANS	3-8
3-06 APPLICATION PROCEDURE.	3-9
3-07 PRE-QUALIFIED OPEN MARKET MANUFACTURED WINDOWS	3-10
APPENDIX A	3-11
APPENDIX B	3-15
APPENDIX C	3-16
CHAPTER 4: DESIGNATED BROADWAY THEATERS	4-1
4-01 TREATMENT OF DESIGNATED BROADWAY THEATER INTERIORS	4-1
4-02 TREATMENT OF DESIGNATED BROADWAY THEATER EXTERIORS	4-2
CHAPTER 5: HISTORIC PRESERVATION GRANT PROGRAM	5-1
5-01 INTRODUCTION.	5-1
5-02 ELIGIBILITY CRITERIA.	5-1
5-03 APPLICATION REQUIREMENTS AND SELECTION CRITERIA. ..	5-1
CHAPTER 6: PROPOSED ALTERATIONS AND NEW CONSTRUCTION OF STRUCTURES AND LANDSCAPES IN THE RIVERDALE HISTORIC DISTRICT.	6-1
6-01 INTRODUCTION	6-1
6-02 DEFINITIONS.	6-1
6-03 STATEMENT OF REGULATORY POLICY.	6-3
6-04 MODIFICATIONS OF AND ADDITIONS TO EXISTING BUILDINGS.	6-3
6-05 REGULATION OF LANDSCAPE IMPROVEMENTS.	6-5
6-06 CONSTRUCTION OF NEW STRUCTURES.	6-6
CHAPTER 7: PERMIT EXPIRATION AND RENEWAL	7-1

7-01 DEFINITIONS:	7-1
7-02 DURATION OF PERMITS.	7-1
7-03 RENEWAL OF PERMITS.	7-2
7-04 EFFECT OF EXPIRATION OF PERMITS.	7-3
7-05 MISCELLANEOUS.	7-3
CHAPTER 8: PROPOSED ALTERATIONS AND NEW CONSTRUCTION OF STOREFRONTS IN THE JACKSON HEIGHTS HISTORIC DISTRICT	8-1
8-01 INTRODUCTION.	8-1
8-02 DEFINITIONS	8-1
8-03 ROUTINE MAINTENANCE	8-4
8-04 STOREFRONT ALTERATIONS	8-5
8-05 PROCEDURE.	8-12
APPENDIX A: ILLUSTRATIONS OF DEFINITIONS OF ARCHITECTURAL ELEMENT	8-14
APPENDIX B: APPLICATION DRAWINGS	8-15
CHAPTER 9: ALTERATIONS TO DESIGNATED BANK INTERIORS	9-1
9-01 INTRODUCTION.	9-1
9-02 DEFINITIONS.	9-1
9-03 ELIGIBLE INTERIORS & SIGNIFICANT FEATURES.	9-2
9-04 CHANGES TO NON-SIGNIFICANT FEATURES.	9-3
9-05 STATE-OF-THE-ART BANKING CHANGES.	9-3
9-06 APPLICATIONS FOR PARTIAL OR COMPLETE REMOVAL OF TELLER COUNTERS.	9-4
9-07 APPLICATION PROCEDURES.	9-4
CHAPTER 10: NOTIFICATION TO LESSEES OF LANDMARKS DESIGNATION & PERMIT REQUIREMENTS.	10-1
10-01 INTRODUCTION.	10-1
10-02 NOTICE TO TENANT OF LANDMARKS DESIGNATION.	10-1
10-03 NOTIFICATION.	10-1
CHAPTER 11: ADMINISTRATIVE ENFORCEMENT	11-1
INTRODUCTION.	11-1
11-01 DEFINITIONS.	11-1
11-02 ENFORCEMENT OF NOTICES OF VIOLATION.	11-2
11-03 SERVICE OF NOTICE OF VIOLATION	11-3
11-04 WARNING LETTER.	11-3
11-05 NOTICE OF VIOLATION; GRACE PERIOD.	11-3
11-06 STOP WORK ORDER	11-3
CHAPTER 12: HISTORIC DISTRICT MASTER PLANS.	12-1
12-01 DISTRICT MASTER PLANS AND AUTHORIZATIONS TO	

	PROCEED.	12-1
12-02	STONE STREET HISTORIC DISTRICT MASTER PLAN IMPLEMENTATION RULES.	12-2
12-03	IMPLEMENTATION RULES FOR THE DISTRICT MASTER PLAN FOR STOREFRONTS ON MADISON AVENUE IN THE UPPER EAST SIDE HISTORIC DISTRICT	12-5
12-04	IMPLEMENTATION RULES FOR THE DISTRICT MASTER PLAN FOR STOREFRONTS ON MADISON AVENUE IN THE METROPOLITAN MUSEUM HISTORIC DISTRICT	12-7
12-05	IMPLEMENTATION RULES FOR THE DISTRICT MASTER PLAN FOR STOREFRONTS ON MADISON AVENUE IN THE CARNEGIE HILL (AND EXTENSION) HISTORIC DISTRICT	12-9
12-06	IMPLEMENTATION RULES FOR THE DISTRICT MASTER PLAN FOR THE DOUGLSTON HISTORIC DISTRICT	12-12

CHAPTER 1: PRACTICE AND PROCEDURE PUBLIC HEARINGS AND MEETINGS OF THE COMMISSION

1-01 QUORUM

1-02 CALENDARING

1-03 WITHDRAWING AND LAYING OVER CERTIFICATE OF APPROPRIATENESS ITEMS

1-04 FINAL ACTIONS

1-05 SUBMISSIONS TO THE RECORD

1-01 QUORUM. A quorum of the Landmarks Preservation Commission shall consist of six Commissioners. Public hearings and public meetings may be conducted without a quorum.

1-02 CALENDARING. The Landmarks Preservation Commission may, upon the adoption of a motion, calendar an item to be considered for landmark designation. A motion to calendar must be approved by the majority of the Commissioners present in order to be adopted. The date of the public hearing on the proposed designation may be set by the motion to calendar or it may be set at some later time by the Chairman, acting at his or her discretion.

1-03 WITHDRAWING AND LAYING OVER CERTIFICATE OF APPROPRIATENESS ITEMS. Once an application has been included on a Certificate of Appropriateness public hearing calendar, it may be withdrawn or laid-over as follows:

(a) Lay-Overs (requests prior to being heard). If an application has been included on a Certificate of Appropriateness calendar and the hearing has not yet occurred, the applicant may request that the application be laid-over to a subsequent public hearing. The applicant must send the Landmarks Preservation Commission a letter indicating that he or she would prefer to be heard on a subsequent hearing and stating that the Commission's time to act on the matter is being extended for an equivalent length of time. Upon receipt of this request staff will withdraw the item and hold it for the following month's hearing. Where the application concerns, in whole or in part, the legalization or curing of a violation, the applicant shall be allowed to lay over the item only once as of right. If the applicant requests a subsequent lay-over, the Chair may at his or her own discretion consider the request a request for withdrawal and may withdraw the item pursuant to the procedure set forth in subsection 1-03(b)(1), or, if the application seeks to legalize a violation, the Chair may keep the item on the calendar and the Commission may act on it at the public hearing. Withdrawal of an application to legalize or cure a violation, in whole or in part, shall be deemed a disapproval for purposes of service of a second or subsequent notice of violation pursuant to section 25-317.1b(4)(a)(ii).

(b) Withdrawals (requests prior to being heard). If an application has been included on a Certificate of Appropriateness public hearing calendar and the hearing has not yet occurred, the application may be withdrawn from the calendar as follows;

(1) by the applicant if the applicant sends a letter to the Landmarks Preservation Commission indicating that he or she wishes to abandon the application as proposed. Staff withdraws the item and generates the "Withdrawn at Staff Level" number from "Permit Application Tracking System," a withdrawal letter is sent to the applicant and the application is closed.

(2) by the staff if new information or design modifications are provided that enable the staff to issue a staff-level permit. Staff withdraws the item from the calendar and issues a staff permit to close the application.

(3) by the staff at the direction of the Director of Preservation if the status of the application changes with respect to scope and completeness.

(c) Withdrawals from calendar (after having been heard). If an application has been included on a Certificate of Appropriateness public hearing calendar and the hearing has taken place, the application can only be withdrawn by the applicant if he or she sends a letter to the Landmarks Preservation Commission indicating that the application is being abandoned as proposed. Upon receipt of this request staff will withdraw the item from the calendar, generate a "Withdrawn at Staff Level" number from "Permit Application Tracking System" and send the applicant a withdrawal letter to close the application. Where the application concerns, in whole or in part, the legalization of a violation, the Chair may, at his or her own discretion, reject the applicant's request to withdraw and the Commission may continue to consider and act on the application as submitted. Withdrawal of an application to legalize or cure a violation, in whole or in part, shall be deemed a disapproval for purposes of service of a second or subsequent notice of violation pursuant to section 25-317.1b(4)(a)(ii).

1-04 FINAL ACTIONS. No final determination or action will be made or taken except by concurring vote of at least six Commissioners.

1-05 SUBMISSIONS TO THE RECORD. The Commission may, upon the adoption of a motion, close the hearing and leave the Record open on a particular item until a stated date to allow for the submission of additional written information. Submissions received after the stated date will be included in the Record provided they are received prior to the Commission's determination or action on the item.

The Commission will neither make a final determination nor take any final action on an item while the Record is open on that item.

CHAPTER 2: ALTERATION OF LANDMARK AND HISTORIC DISTRICT BUILDINGS

SUBCHAPTER

A APPLICATION PROCEDURE

B SPECIFIC ALTERATIONS

C EXPEDITED REVIEW OF CERTAIN APPLICATIONS FOR CERTIFICATES OF NO EFFECT

SUBCHAPTER A: APPLICATION PROCEDURE

2-01 APPLICATION SIGNATURES NECESSARY FOR WORK PERMITS

2-02 MASTER PLANS AND AUTHORIZATIONS TO PROCEED

2-03 PROCESS FOR COMPLETING APPLICATION: STAFF WITHDRAWAL OF THE APPLICATION

2-04 NOTICES OF VIOLATION - NEW APPLICATIONS

2-01 APPLICATION SIGNATURES NECESSARY FOR WORK PERMITS. All application forms to perform any work on a designated landmark or on a property in a designated historic district must be signed by the owner of the property. An application for work on or in a cooperative building must be signed by the President or other appropriate officer of the Co-op Board. The signature of the managing agent of the cooperative building is not sufficient. An application for work on or in the areas and portions of a condominium building in common ownership must be signed by the President or other appropriate officer of the Condominium Association. An application for work on or in an individual condominium unit must be signed by the owner of that unit.

2-02 MASTER PLANS AND AUTHORIZATIONS TO PROCEED. An owner of a designated property may apply for approval of a master plan when the proposal involves repetitive alteration of architectural features (such as windows, through-wall air conditioning installations, storefronts, etc.) and when those alterations are not planned to occur all at once, but rather in increments through time. A master plan can be approved by a Certificate of Appropriateness or by a Permit for Minor Work depending on the work which it covers.

In both cases the master plan sets a standard for future changes involving the architectural features in question and specifically identifies drawings and other documents which contain the approved design in detail. Once a master plan is approved and the owner wishes to move forward with a portion of the work covered by the master plan, a completed application form is filed with the Commission describing the scope of work (for example: 8 front windows on the 12th floor) and stating that the work will conform to the approved master plan drawings and other documents on file with the Landmarks Preservation Commission. The staff of the Preservation Department will review the application to ascertain that all proposed work is covered by a master plan, and will send the owner an "Authorization to Proceed" letter allowing

the work to proceed. The Authorization to Proceed is sent prior to the commencement of the work and is contingent on adherence to the approved master plan drawings.

2-03 PROCESS FOR COMPLETING APPLICATION: STAFF WITHDRAWAL OF THE APPLICATION.

(a) All applications for work on designated properties received by the Landmarks Preservation Commission are assigned to a professional staff member in the Preservation Department who will handle the project. The staff person will review the proposal to ascertain whether the materials submitted are sufficient for a determination to be made. If the materials are sufficient, staff will certify the application as complete and issue the appropriate permit or take other action. If the completed application requires a Certificate of Appropriateness, staff will arrange for the item to be included in the next scheduled Certificate of Appropriateness public hearing calendar.

If the application requires further clarification and/or additional documentary materials, staff will contact the owner and/or applicant by telephone to discuss the proposal and, if necessary, arrange a meeting or site visit. Staff will follow the conversation up by providing a materials checklist calling out those supplementary materials required to certify the application as complete. If contact has been limited to a telephone conversation, the checklist will be mailed to the applicant. If a meeting is set up, the checklist may be supplied during the course of the meeting.

As soon as all the materials requested have been received, staff will certify the application as complete and process the application. However, if the required materials have not been received 60 working days from the date on the materials checklist, staff will send a follow-up letter to the applicant reminding him/her that the application is still incomplete and informing him/her that unless the materials required are received within the next 30 working days the application will be deemed withdrawn. A copy of the most recent materials checklist will be included with the letter. If the applicant does not submit sufficient material within 90 days of the date on the materials checklist, staff should withdraw the application by sending a staff withdrawal letter including the docket number of the application and a "Withdrawn at Staff Level" number generated by "Permit Application Tracking System." The application will then be closed. The staff withdrawal letter will be sent to the owner and applicant with copies forwarded to the file, supervisor, and the Director of Preservation. Along with the withdrawal letter a blank "Application for Work on Designated Properties" will be included for the use of the applicant should he or she wish to re-apply.

(b) Notwithstanding the time periods set forth in subdivision (a), where an application seeks to legalize or cure a violation, an applicant must submit all materials required by the materials checklist within 20 working days of the date of the materials checklist. If the materials are not submitted, the staff shall send a follow-up letter that shall inform the

applicant that the application may be withdrawn by the staff unless all required materials are submitted within 15 working days of the date of the follow-up letter. If the applicant fails to submit all required materials within 55 working days of the date of the first materials checklist, the staff may withdraw the application as set forth in subdivision (a). Withdrawal of an application to legalize or cure a violation, in whole or in part, shall be deemed a disapproval for purposes of service of a second or subsequent notice of violation pursuant to section 25-317.1b(4)(a)(ii).

2-04 NOTICES OF VIOLATION - NEW APPLICATIONS. The Landmarks Preservation Commission will not process an application for work on a designated property when a Landmarks Preservation Commission Notice of Violation is in effect against that property. A Notice of Violation in effect against that property indicates non-compliance with the Landmarks Law.

(a) Upon receipt of an application, staff must verify that no Notice of Violation is in effect against the property. In the event that a Notice of Violation is in effect, staff should proceed as follows:

Obtain copies of all Notices of Violation and Notices to Stop Work for the file.

Contact the owner/applicant to inform them that because a Notice(s) of Violation is (are) in effect staff cannot process an application for new work until the Notice(s) has (have) been rescinded.

Send a letter to the applicant explaining that staff cannot process the new application because a Notice(s) of Violation is (are) in effect against the property, that processing can only commence upon rescission of the Notice(s) or when the applicant begins to address the Notice(s). Along with the letter send copies of the Notice(s), an application form, and instructions for filing. Send copies of the letter to the Director of Preservation, Supervisor, and the Director of Enforcement.

(b) Exceptions to this procedure. Staff may issue permits for new work when a Notice of Violation is in effect in the following instances:

(1) The proposed work will correct a hazardous condition.

(2) The proposed work addresses the prevention of deterioration affecting the building, and the work will clearly further the continuing preservation of the building.

(3) A permit has been issued to correct work cited in a Notice of Violation, and an escrow agreement or other acceptable form of assurance has been established to

provide a mechanism, acceptable to the Landmarks Preservation Commission, that ensures that the work approved under the permit to correct the Notice of Violation will be completed within a specified time period.

SUBCHAPTER B: SPECIFIC ALTERATIONS

2-11 INSTALLATION OF HEATING, VENTILATING AND AIR CONDITIONING EQUIPMENT

2-12 RULES FOR INSTALLATION OF AWNINGS

2-13 REMOVAL OF FIRE ESCAPES

2-14 SANDSTONE RESTORATION AND REPLACEMENT

2-15 NEW WINDOW OPENINGS

2-16 REAR YARD ADDITIONS OR ENLARGEMENTS

2-17 RESTORATION OF A BUILDING OR BUILDING FACADE FEATURES

2-18 TEMPORARY INSTALLATIONS

2-19 PROPOSED CONSTRUCTION OF ROOFTOP ADDITIONS

2-11 INSTALLATION OF HEATING, VENTILATING AND AIR CONDITIONING EQUIPMENT.

(a) Introduction.

These rules are issued to assist the public in applying to the Landmarks Preservation Commission for approval of the installation of heating, ventilation and air conditioning equipment, in buildings which are designated landmarks or are within designated historic districts. These rules enunciate Commission policy with respect to such installation and also explain the procedures required to apply for a permit.

The visual character of the exterior wall cladding, the pattern of window openings on the facades, and the ornamental elements used to articulate the exterior walls are important and integral parts of the design of buildings. In most historic buildings, these three elements were carefully combined to help define the style and character of the building. It is important to retain the visual integrity of the exterior walls, the regular pattern of the window bays, and the ornamental elements.

Therefore, the Commission, in making a determination on proposed installations of window, through-wall or roof- or yard-mounted HVAC equipment, evaluates the effect of the proposal on the aesthetic, historical and architectural values and significance of the landmark or of the building in an historic district. The Commission considers, among other matters, the architectural style of the building and the design, finish, material, method of installation and color of the proposed work.

These rules are based on the following principles:

- (1) The distinguishing historical qualities or character of a building's structure or site and its environment should not be destroyed. The removal or alteration of any distinguishing architectural feature should be avoided.

(2) The visual integrity of the building's exterior walls should be maintained.

The goal of these rules is to facilitate the approval of appropriate HVAC installations in landmarked buildings. Certain installations can be approved at staff level in conformance with the procedures and criteria set forth in these rules. Proposed installations that do not conform to these rules require a Certificate of Appropriateness review by the full Commission in accordance with the Landmarks Law. Applicants are strongly encouraged to develop building master plans for the installation of HVAC equipment.

(b) Definitions

Authorization to Proceed (ATP). "Authorization to Proceed (ATP)" shall mean a letter from LPC notifying an applicant that the proposed HVAC installations have been found to be in conformance with the provisions of an approved Master Plan.

Decorative masonry. "Decorative masonry" shall mean terra cotta, cast-stone or natural stone (such as limestone, marble, brownstone or granite) facade areas and/or any ornamental feature which is a component of the facade such as, belt courses, banding, water tables, cornices, corbelled brick work, medallions, enframements, and surrounds, and ornamental bonding patterns, e.g. tapestry brick or diaper patterns.

HVAC equipment. "HVAC equipment" shall mean window, through-wall and yard mounted heating, ventilation, and air conditioning equipment, including window louvers, wall-mounted grilles and stove, bathroom and/or dryer vents.

Landmarks Law. "Landmarks Law" shall refer to Section 3020 of the New York City Charter and Chapter 3 of Title 25 of the Administrative Code of the City of New York.

LPC staff. "LPC staff" shall mean the staff of the Landmarks Preservation Commission acting in the Commission's agency capacity.

Primary facade. "Primary facade" shall mean a facade facing a street or a public thoroughfare that is not necessarily a municipally dedicated space, such as a mews or court.

Secondary facade. "Secondary facade" shall mean a facade that does not face a public thoroughfare or mews or court.

Segmental or curved head window. "Segmental or curved head window" shall mean a window with a non-rectilinear sash or frame as illustrated and defined as a special window in Appendices A and C of Chapter 3 of these rules.

Significant feature. "Significant feature" shall mean an exterior architectural component of a building that contributes to its special historic, cultural, and/or aesthetic character, or in the case

of an historic district, that reinforces the special characteristics for which the historic district was designated.

Terms not otherwise defined in these rules shall have the meanings given them in the Landmarks Law.

(c) Installation of HVAC equipment within window openings (1) No permit is required for installation of HVAC equipment which require only raising the lower sash of a double-hung window, or which require only opening a casement leaf, transom, hopper or awning window.

(2) A permit is required for all other types of HVAC equipment installations within windows in individual landmarks and buildings in historic districts.

(i) Installations of HVAC equipment within window openings on primary facades of individual landmarks and building in historic districts.

(A) Residential buildings, including buildings originally designed as residences which were subsequently converted to other uses:

((a)) Rowhouses, detached houses, carriage houses, small apartment buildings, tenements, and hotels: In buildings originally constructed as private residences, carriage houses, as well as small apartment houses and other types of multiple dwellings which are six stories or less in height and with a street frontage of forty (40) feet or less, the small scale, limited areas of plain masonry and potential for affecting the significant architectural and historic character of the buildings require that proposals for installations on primary facades be reviewed for a Certificate of Appropriateness ("CofA").

((b)) Large apartment buildings and hotels: In large apartment buildings, hotels and other types of multiple dwellings which either have a street frontage of forty-one (41) feet or greater or which are seven or more stories in height, a Permit for Minor Work ("PMW") or Certificate of No Effect ("CNE") may be issued for permanent installations of HVAC equipment, louvers and vents in window openings if the proposal meets the following criteria:

((i)) the window is not a special window as defined in Chapter 3, Appendix C of these rules except for segmental or curved head windows which do not possess any other characteristics of a special window; and

((ii)) the installation involves only removing glazing from

one of the double-hung sash or one portion of a casement window or removing the window sash and retaining the window frame; and

((iii)) the location of the unit forms part of a regular pattern of installations within window bays on the facade; and

((iv)) the louver or vent will be mounted flush with the sash or directly behind the sash; and

((v)) the louver or vent is finished to blend into the fenestration pattern; and

((vi)) no significant architectural feature of the building will be affected by the installation.

(B) Commercial and loft buildings: In commercial and loft buildings originally designed to serve commercial/retail/ warehouse uses, including cast-iron fronted buildings, department stores, banks and office buildings, a PMW or CNE may be issued for the permanent installation of HVAC equipment, louvers or vents if the proposal meets the following criteria:

(a) the window is not a special window as defined in Chapter 3, Appendix C of these rules except for segmental or curved head windows which do not possess any other characteristics of a special window; and

(b) the proposal involves removing the glazing from all or part of the sash, or removing the window sash and retaining the window frame; and

(c) the location of the unit forms part of a regular pattern of installations in window bays on the facade; and

(d) the louver or vent will be mounted flush with the sash or directly behind the sash; and

(e) the louver or vent will be finished to blend into the fenestration pattern; and

(f) no significant architectural feature of the building will be affected by the installation.

(ii) Installations of HVAC equipment within window openings on secondary facades in individual landmarks and buildings within historic districts. A PMW or CNE will be issued for the installation of HVAC equipment within window openings on such facades if the proposal meets the following criteria:

- (A) the unit will be installed within an existing opening; and
- (B) the window is not a special window as defined in Chapter 3, Appendix C of these rules except for segmental or curved head windows which do not possess any other characteristics of a special window; and
- (C) the louver or vent will be finished to blend into the fenestration pattern; and
- (D) no significant architectural feature of the building will be affected by the installation.

(d) Installations of through-wall HVAC equipment (1) Through-wall installation of HVAC equipment on primary masonry facades

(i) Individual Landmarks. Proposals for installations on primary facades must be reviewed for a CofA.

(ii) Buildings within historic districts.

(A) Residential buildings, including buildings originally designed as residences which were subsequently converted to other uses:

(a) Rowhouses, detached houses, carriage houses, small apartment buildings, tenements, and hotels. In buildings originally constructed as private residences or carriage houses, as well as small apartment houses and other types of multiple dwellings which are six stories or less in height and with a street frontage of forty (40) feet or less, the small scale, limited areas of plain masonry and potential for affecting the significant architectural and historic character of the buildings require that proposals for installations on primary facades be reviewed for a CofA.

(b) Large apartment buildings and hotels. In large apartment buildings, hotels and other types of multiple dwellings which either have a street frontage of forty-one (41) feet or greater or which are seven or more stories in height, a PMW or CNE may be issued for installation of through-wall HVAC equipment if the proposal meets the following criteria:

- (1) the proposed installation will be centered beneath the window opening, or, if the window opening is wide enough to accommodate more than one set of sashes, is placed to conform to the predominant existing pattern of installations; and
- (2) the exterior grille will be a rimless type architectural grille; and
- (3) the exterior grille will be mounted flush with the surrounding masonry; and
- (4) the exterior grille will have painted finish or a factory applied enameled finish which matches the color of the

- surrounding masonry; and
- (5) the proposed location corresponds to an established regular pattern of installations; and
- (6) the proposal calls for only the installation of one unit per room except for corner rooms in which the installation of one unit per facade will be permitted; and
- (7) no decorative masonry or other significant architectural feature of the building will be affected by the installation.

(B) Manufacturing and loft buildings. Because of the architectural character of buildings of these types, installations proposed for primary facades of loft buildings originally designed to serve commercial/retail/warehouse uses, including cast-iron fronted buildings, department stores, and banks, must be reviewed for a CofA.

(C) Other buildings. For other buildings that do not fall into any of the previously described categories, the finding of appropriateness of through-wall HVAC installations on primary facades will be made on a case-by-case basis. Variations in design of these specialized buildings preclude the applicability of rules. Such specialized building types include churches and synagogues, hospitals, schools, and libraries.

(2) Installations of through-wall HVAC equipment on visible secondary masonry facades. A PMW or CNE may be issued for installation of through-wall HVAC equipment on a secondary facade of an individual landmark or of a building within an historic district if the proposal meets the following criteria:

- (i) the unit will be A) centered beneath or above a window opening if the vent or louver exceeds 144 square inches in surface area, or B) installed below, above, or to the side of a window opening if the vent or louver is 144 square inches or less in surface area; or C) installed in a uniform pattern on portions of secondary facades devoid of windows (variations from the predominant existing pattern on the building may be permitted if the applicant does not have interior space which would permit such installation in conformance with such pattern); and
- (ii) the exterior grille will be mounted flush with the exterior wall except that if the vent or unit is 25 square inches or less in surface area, a projection forward of not more 5 inches may be permitted if the projection does not have an adverse effect on the secondary facade; and
- (iii) the exterior grille will be finished in a manner which approximates the color of the surrounding masonry; and
- (iv) no decorative masonry or other significant architectural feature of the building will be affected by the installation.

(3) Installation of HVAC equipment on non-visible secondary masonry facades. A PMW or CNE may be issued for installation of through wall HVAC equipment on a secondary facade if the proposal meets the following criteria:

- (i) the installation will not be visible from any public thoroughfare; and
- (ii) the grille will be set flush with the masonry wall except that if the vent or unit is 25 square inches or less in surface area, a projection forward of not more than 5 inches may be permitted if the projection does not have an adverse effect on the secondary facade; and
- (iii) no decorative masonry or other significant architectural feature of the building will be affected by the installation.

(4) A Certificate of Appropriateness is required for installation of through-wall HVAC equipment on facades made of materials other than masonry.

(e) Installation of HVAC equipment in yards and areaways of landmarks and buildings in historic districts. (1) A PMW or CNE may be issued for the installation of HVAC equipment in a location in the side or rear yard if the proposal meets the following criteria:

- (i) the installation will not be visible from any public thoroughfare; and
- (ii) the installation will not affect any significant architectural feature of the landmark or of a building in an historic district.

(2) Proposals for installation of HVAC equipment in front yards or in a location in a side or rear yard which is visible from a public thoroughfare require review for a CofA.

(f) Master Plans. (1) A master plan for the installation of HVAC equipment over a period of time can be approved under a PMW if the plan is in conformance with these rules. After the permit is issued, proposed installations will require applications requesting an Authorization to Proceed (ATP).

(2) The master plan shall set forth standards for future changes and shall specifically identify such standards by drawings, including large scale details of installation specifications, specific unit locations and installation types.

2-12 RULES FOR INSTALLATION OF AWNINGS (Effective April 25, 1999)

(a) Introduction: These rules are issued to assist building owners in applying to the Landmarks Preservation Commission (“Commission”) for approval to install or repair awnings. The rules set forth Commission policy with respect to such installation and repair and explain the procedures and criteria required to apply for and receive a permit from the staff of the Commission. The goal of these rules is to facilitate the approval of appropriate awnings for designated buildings. Certain awning repairs and installations can be approved at staff level in conformance with the procedures and criteria set forth in these rules. Proposed installations or alterations that do not conform to these rules require a certificate of appropriateness review by the full Commission in accordance with the procedures and criteria set forth in section 25-305, 25-307 and 25-308 of the

New York City Administrative Code.

These rules are based on the following principles:

(1) Awnings were historically employed for weather protection above residential windows and doors and for advertising as well as weather protection above storefronts.

(2) The location of awnings historically corresponded to the size and shape of the openings they covered, and awnings were installed directly above the wall openings they covered.

(3) Removal or damage of any significant feature is to be avoided in connection with the installation of awnings.

Applicants are encouraged to submit applications for master plans, pursuant to section 2-02 of Title 63 of these Rules, for commercial portions of buildings with multiple storefronts or for residential buildings, which will permit the installation of awnings over a period of time in a single building or building complex.

(b) Definitions. As used in these Rules, the following terms shall have the following meanings:

"Awning" shall mean a metal frame clad with fabric attached over a window, door, porch opening or storefront to provide protection from the weather.

"Facade" shall mean an entire exterior face of a building.

"Fixed awning" shall mean an awning with a nonretractable metal frame clad with fabric.

"Historic fabric" shall mean a building's original or significant historic facade construction material or ornament, or fragments thereof.

"Landmarks Law" shall refer to Section 3020 of the New York City Charter and Chapter 3 of Title 25 of the Administrative Code of the City of New York.

"Lintel" shall mean the horizontal member or element above a door or window opening.

"LPC staff" shall mean the staff of the Landmarks Preservation Commission acting in the Commission's agency capacity.

"Primary facade" shall mean a facade facing a street or a public thoroughfare that is not necessarily a municipally dedicated space, such as a mews or court.

"Residential awning" shall mean any awning on a residential building and any awning on a commercial or mixed-use building except for storefront awnings.

"Retractable awning" shall mean an awning attached to a frame which allows it to be extended

out or folded or rolled back tight against the building facade.

"Significant feature" shall mean an exterior architectural component of a building that contributes to its special historic, cultural, and/or aesthetic character, or in the case of an historic district, that reinforces the special characteristics for which the historic district was designated.

"Skirt" shall mean a bottom finishing piece of fabric that hangs from the lower edge of an awning.

"Storefront" shall mean the first story area of the facade that provides access or natural illumination into a space used for retail or other commercial purposes.

"Storefront opening" shall mean the first story area of the facade that is framed by piers or walls on the sides and a lintel or arch above, and that contains a storefront.

"Transom" shall mean the glazed area above a display window or door separated from the main window area or door by a transom bar.

Terms not otherwise defined in these rules shall have the meanings given them in the Landmarks Law.

(c) Routine Maintenance. A permit is not required to undertake the following types of ordinary repair and maintenance work:

- (1) Seasonal removal and installation of LPC approved window awnings.
- (2) Fabric patching in a matching material.
- (3) Minor repairs or adjustments to the rolling or folding arm mechanism of an awning's frame.
- (4) Cleaning of awning material.

Ordinary repair and maintenance does not include replacement of, or repairs to, significantly damaged or deteriorated awning frames and armatures.

(d) Recladding and Retention of Existing Awnings.

(1) LPC staff shall issue a certificate of no effect or a permit for minor work for recladding of existing awnings if the proposed recladding meets both of the following criteria:

- (i) The awning to be reclad was present at the time of designation or was previously approved by an LPC permit; and
- (ii) The existing frame will be reclad in a material and finish that conforms to the criteria set forth in Section 2-12(e)(7)-(9) or 2-12(f)(9)-(11) of these rules.

(2) In the event a new storefront is being installed, an existing storefront awning in noncompliance with the criteria set forth in subsection (f) below cannot be retained unless the

applicant can demonstrate to LPC staff that the new storefront installation will not require even the temporary removal of the existing awning or awnings.

(e) Installation of New Awnings on Residential Windows, Doors and Porches. LPC staff shall issue a certificate of no effect or a permit for minor work for new awnings on residential windows, doors and porches if the proposed awning meets all of the following criteria applicable for such installation:

- (1) Awnings installed on residential windows, doors and porches shall be retractable awnings.
- (2) Awnings shall be installed at or below the lintel and shall conform to the size and shape of the window or door opening.
- (3) The attachment of the awning will not cause the loss of, damage to, or hide or obscure any significant feature.
- (4) Awnings shall project at an angle and be of a length, size and slope which are proportional to the size and height of the window or door.
- (5) Awnings at terraces and architectural setbacks may extend over more than one opening, so long as the overall length of the awning is proportional to the size and length of the terrace or setback and the depth does not exceed the depth of the terrace or setback.
- (6) Awnings on porches shall conform to the bay structure and proportions of the porch.
- (7) All awnings on a residential building or on the residential portions of a mixed-use building must match in terms of fabric color and pattern if installed on primary or visible secondary facades.
- (8) Awnings shall be clad only with water repellent canvas with a matte finish or other fabric of a similar appearance.
- (9) Awning fabric shall consist of a solid color or vertical stripes that harmonize with the historic color palette of the building. No lettering or signage is permitted on residential awnings except for an address number on an awning over an entrance, and the numbers of such address shall be no greater than six inches in height.

(f) Installation of New Awnings on Storefronts. LPC staff shall issue a certificate of no effect or a permit for minor work for new awnings on ground story storefronts, display windows and doorways if the proposed work meets all of the following criteria applicable for such installation:

- (1) The awning must be retractable on Individual Landmarks, on storefront restorations approved by a restorative certificate of no effect (Title 63 Section 2-17(c)), and on buildings which were designed with integral retractable awning housings as part of the storefronts. In all other cases, the awning may be either retractable or fixed. If fixed, the awning shall have a straight slope and be open at the sides. If retractable, the awning shall have a straight or curved slope and may or may not have side panels. Retractable awnings may follow the curved configuration of the window or door openings over which they are installed. If a display window or doorway opening has an arched or segmental head, the awning must be retractable if it is installed at the head of the window, but may be fixed if is installed at the rectilinear transom bar. Both retractable

and fixed awnings may or may not have a skirt. Awning skirts must be unframed. The skirt height shall be proportional to the height and size of the awning.

(2) The attachment of the awning will not cause the loss of, damage to, or hide or obscure any significant feature.

(3) The awning shall be installed at or directly below the lintel or transom bar, except that the awning may be attached up to eight inches above the lintel where:

(i) a roll-down security gate that either was present at the time of designation or was previously approved by the Commission makes it impossible to install the awning at the lintel or transom bar; or

(ii) installing the awning at the lintel or transom bar will result in the lowest framed portion of the awning being less than eight feet above the sidewalk.

Where the awning is installed above the lintel, the awning encroachment above the lintel shall be the minimum required to accommodate the conditions described above in subparagraphs (i) and (ii) and in no instance shall exceed eight inches.

(4) In cases where the storefront itself projects from the facade, the awning must be attached to the projecting storefront below the storefront cornice or cap.

(5) The length of the awning shall not exceed the length of the storefront opening or the associated window opening, and the edges of the awning shall be aligned as closely as possible with the inside face of the principal piers of the storefront, or the window opening.

(6) The underside of the awning shall be open.

(7) The lowest framed portion of the awning shall be at least 8 feet above the sidewalk. The lowest unframed portion shall be at least 7 feet above the sidewalk.

(8) The awning shall project at an angle and be of a length, size and slope which are proportional to the size and height of the window or door.

(9) The awning shall be clad only with water repellent canvas with a matte finish or other fabric of a similar appearance.

(10) Signs, such as lettering or graphics, are permitted to be painted on the awning skirt only; no lettering or graphics shall be permitted on the sloped portion of the awning. The size of lettering shall be proportional to the height of the awning skirt.

(11) Awning fabric shall consist of a solid color or vertical stripes that harmonize with the historic color palette of the building.

(g) Applicability. The provisions of this section shall not apply to proposals to install awnings:

(1) On buildings subject to a building or district master plan, or other special rule approved by the Commission, governing the installation and characteristics of an awning; and

(2) On buildings, including historic modifications thereof, that did not originally or historically have awnings, including without limitation thereof public and institutional buildings such as houses of worship, schools, post offices and fire houses. Where the LPC staff reasonably believes that a building did not originally or historically have an awning, the LPC staff shall, at the applicant's request, calendar the proposal for a certificate of appropriateness public hearing. The applicant may request a meeting with the Director of Preservation or, in his or her absence, the Deputy Director, to discuss the

LPC staff's interpretation of these rules.

2-13 REMOVAL OF FIRE ESCAPES. The following will clarify instances in which staff may issue a Certificate of No Effect (CNE) for the removal of fire escapes from designated buildings.

The removal of a fire escape requires either a CNE or a Certificate of Appropriateness (CofA). If the fire escape is a significant protected feature, then a CofA is required to approve its removal. However, staff may issue a CNE for a fire escape removal if it determines:

(a) that the fire escape is not a significant protected feature on the building based on the finding that:

(1) the fire escape is not original to the building, and

(2) the fire escape does not have architectural merit in itself, and

(3) the fire escape is not mentioned in the LPC designation report, and

(4) the building with the fire escape is not located within an historic district in which fire escapes are significant architectural elements that contribute to the special architectural and historic character for which that historic district was designated;

(b) That any damage to the facade will be repaired to match the adjacent fabric (patching any holes would be invisible enough to have "no effect" on the significant protected feature of the building);

(c) that the removal of the fire escape will not leave gaps, holes, or unsightly conditions on the facade. Occasionally, the installation of a fire escape requires the removal of architectural elements or portions of architectural elements (e.g., cornices). If the applicant is not prepared to remedy these conditions in connection with the removal of the fire escape, staff will have to make a judgement as to whether or not it would be desirable to allow the removal. If the applicant is willing to make restorative repairs, staff will have to decide whether these would require a Permit for Minor Work (PMW) or a CofA. It would be inappropriate to include these restorative repairs on a CNE since obviously they would have an effect on the significant protected features of the building. If the level of restoration requires a CofA, a CNE should not be issued for the removal, but rather the removal should be calendared for a public hearing with the restoration.

2-14 SANDSTONE RESTORATION AND REPLACEMENT. The staff may issue a Permit for Minor Work for the restoration or replacement of sandstone/brownstone elements and the following guidelines should be used in evaluating such proposals:

(a) For buildings that have especially fine ornament or distinctive or unique carvings

where damage is minimal, the staff may issue a Permit for Minor Work for an application to consolidate the original significant fabric.

(b) For buildings where the decorative features are simple, not necessarily unique, stoops with damage to the treads or other kinds of damage to the facade, the staff may issue a Permit for Minor Work for an application to remove the original sandstone surfaces and replace them with a cementitious mix. In reviewing the application, the staff should find that:

(1) documentation or site inspection reveals that the existing brownstone surface is exfoliating, damaged or otherwise unsound;

(2) the proposal calls for the replication of the original texture, color, profiles and details;

(3) the proposal calls for damaged stone to be cut back to sound stone and the new surface be keyed into the sound stone and built up in successive layers using a cementitious mix with the top layer tinted and finished to match the original sandstone texture and color. In some cases a sample patch should be requested for inspection and approval. The use of wire lath is never acceptable;

(4) the methods and materials proposed by contractors have been provided in the form of specifications, copies of contracts, or written in a letter.

2-15 NEW WINDOW OPENINGS. (As amended 12/21/99) Staff is authorized to issue a Certificate of No Effect for new window openings and sash when the following conditions are met:

(a) Visible window openings on secondary facades:

(1) the new window opening(s) and sash retain the same general shape and pattern as existing windows on the same facade, or, where there are no existing window openings, the new window opening will be located in a place and be of a size and shape where it can form the basis for a regular and consistent pattern, and the new sash does not detract from the sash on the primary facade;

(2) the location of new window openings is consistent and regular; and

(3) new window opening and sash do not detract from the significant architectural features of the building or adjacent buildings by virtue of their proximity to such features.

(b) For nonvisible or minimally visible window openings on secondary facades:

- (1) the proposed window opening does not alter or destroy other protected features, nor does the proposed window opening or sash detract from such protected features by their proximity to such features.
 - (2) For purposes of this subsection (b), a new window opening shall mean (i) a window opening where none previously existed or (ii) a combination of two or more horizontally adjacent windows, provided such adjacent windows are, or will be once all of the approved work is complete, located in the same room. In addition to being combined, such horizontally adjacent windows may be enlarged in height by up to 10 percent of the height of the largest existing window opening being combined.
 - (3) For purposes of section 2-15(b), the term “minimally visible” shall mean that the proposed window opening and sash are only partially visible from a public thoroughfare and that the window opening and sash are visible from such an angle and/or such a distance that they do not call attention to themselves and do not detract from the significant architectural features of the building or historic district.
- (c) For purposes of this section 2-15, the term “secondary facade” shall mean a facade that does not face a public thoroughfare or mews or court and that does not possess significant architectural features.

2-16 REAR YARD ADDITIONS OR ENLARGEMENTS. Standards for issuing staff level Certificates of No Effect (CNE) for rear yard additions or enlargements:

- (a) Application is not for an addition that would extend to the rear lot line or substantially eliminate the presence of a rear yard.
- (b) Rear of building has no significant architectural features which would be lost or damaged as a result of the construction of the addition.
- (c) Proposed addition is not visible from a public thoroughfare or right of way.
- (d) Other rear yard incursions exist within the block (in the case of buildings in Historic Districts).
- (e) In the case of a rowhouse, the rear of the building (or buildings) involved retains the scale and character of an individual rowhouse.
- (f) Proposed work complies with the Zoning Resolution and will not require special permit or a variance.
- (g) In buildings with rear cornices, corbeled brickwork on the parapet, or other distinctive

roof silhouettes, the rear addition does not rise to the full height of the building.

(h) The rear facade will not be removed from the entire width of the building; instead, existing openings are being modified to provide access into the addition. This approach retains original fabric and lessens structural intervention.

If all the above standards are met, a CNE may be issued; otherwise, consult with the Director of Preservation. Calendaring for a Certificate of Appropriateness public hearing may be required.

2-17 RESTORATION OF A BUILDING AND BUILDING FACADE FEATURES.

(a) Introduction. These rules are issued to assist building owners in applying to the Landmarks Preservation Commission for approval of applications to undertake the restoration of a building element or group of building elements on a designated property. The rules set out Commission policy with respect to such work. The goal of these rules is to facilitate and expedite the approval of restoration work proposed for designated properties. Proposed restoration work that does not conform to these rules requires a Certificate of Appropriateness review by the full Commission in accordance with the Landmarks Law.

(b) Definitions. As used in these Rules, the following terms have the following meanings:

Facade. "Facade" shall mean an entire exterior face of a building.

Historic appearance. "Historic appearance" shall mean the visual appearance of a structure or site at a specific point in time after it has undergone alterations or additions which enhance or contribute to the building or site's special architectural, aesthetic, cultural or historic character.

Historic fabric. "Historic fabric" shall mean a building's original or significant historic facade construction material or ornament, or fragments thereof.

Landmarks Law. "Landmarks Law" shall refer to Section 3020 of the New York City Charter and Chapter 3 of Title 25 of the Administrative Code of the City of New York.

LPC staff. "LPC staff" shall mean the staff of the Landmarks Preservation Commission acting in the Commission's agency capacity.

Original appearance. "Original appearance" shall mean the visual appearance of a structure or site at approximately the time of its completed initial construction.

Terms not otherwise defined in these rules shall have the meanings given them in the Landmarks Law.

(c) Restoration Work. The LPC staff will issue a Certificate of No Effect or a Permit for Minor Work for the restoration of building facade(s) or individual facade element(s) (including but not limited to roofs and cornices, stoops, storefronts, window and door openings, window and door enframements, ironwork, porches and siding) to their original or historic appearance if the staff determines that the proposed restorative work satisfies the following conditions:

- 1) The basis for the design of the proposed restoration's authenticity is documented by a) photographic evidence, or b) physical evidence on the building, or c) original or historic drawings or documents, or d) matching buildings. If there is no available documentary evidence as set forth in subsections (a) - (d) and the applicant certifies that he or she (or a designated representative) has searched for historic drawings, documents or photographs at the resources listed in Appendix A of Chapter 2, the design may be based on that found in buildings of similar age and style that contain stylistic elements that follow a set pattern or type.
- 2) The restoration would not cause the removal of significant historic fabric (such as Victorian period features on an earlier structure) that may have been added over time and that are evidence of the history and development of a building, structure, or site.

2-18 TEMPORARY INSTALLATIONS. Staff of the Landmarks Preservation Commission is authorized to issue a Certificate of No Effect (CNE) for proposals calling for the temporary installation of signs, banners or other temporary installations such as various forms of artwork or kiosks, if the following criteria are met:

- (a) "Temporary Installation" is defined as an installation for sixty (60) days or less for signs and banners or one (1) calendar year or less for other temporary installations. The duration of any temporary installation authorized under this rule shall be specified in the CNE and shall be for a single period not to exceed sixty days for signs and banners or one year for other temporary installations; and
- (b) the installation will cause no damage to significant protected architectural features of the property; and
- (c) an acceptable plan and time schedule for the dismantling of the property has been submitted to the Commission as a component of the application. In the case of artwork, the applicant is also required to submit a written instrument signed by the artist and the building owner that evidences the owner's authority to remove the artwork when the temporary installation permit expires and that waives any protection under applicable federal or state law afforded to the artist or artwork that would prevent such removal at the expiration of the temporary permit, including but not limited to, the Visual Artists Rights Act of 1990, 17 U.S.C. 101 *et seq.* and Article 14 of the New York State Law on Arts and Cultural Affairs; and

(d) if the applicant is not a public or quasi-public agency, an escrow agreement or other adequate assurance acceptable to the Commission is provided to establish that a mechanism is available for the removal of the installation upon expiration of the permit should the applicant fail to remove the installation.

2-19 PROPOSED CONSTRUCTION OF ROOFTOP ADDITIONS.

(a) Definitions. As used in this section, the following terms shall have the following meanings:

Demolition. "Demolition" shall mean dismantling or razing of all or part of an existing Improvement.

Improvement. "Improvement" shall mean any building, structure, place, work of art or other object constituting a physical betterment of real property, or any part of such betterment.

Landmarks Law. "Landmarks Law" shall refer to New York City Charter Section 3020 and Chapter 3 of Title 25 of the Administrative Code of the City of New York.

Landmarks Preservation Commission. "Landmarks Preservation Commission" shall mean the Landmarks Preservation Commission acting in its agency capacity to implement the Landmarks Law.

Mechanical equipment. "Mechanical equipment" shall include, but not be limited to, heating, venting and air conditioning equipment, watertanks and their supporting structures, satellite dishes, stair and elevator bulkheads, screens, dunnages, baffles and other accessory installations but shall not include telecommunication equipment and conventional television antennas. For the purpose of this rule, mechanical equipment shall also include unenclosed decks, garden trellises, or associated railings.

Minimally visible. "Minimally visible" shall refer to any rooftop addition which when viewed from any public thoroughfare, projects into the maximum line of sight from such public thoroughfare by not more than 12 inches in height, or, due to its placement and size does not call attention to itself nor detract from any significant architectural features.

Occupiable space. "Occupiable space" shall mean a room, or enclosure and accessory installations thereof, which are intended for human occupancy or habitation.

Permit. "Permit" shall mean any permit other than a Notice to Proceed issued by the Landmarks Preservation Commission in accordance with the Landmarks Law:

(a) "PMW shall mean Permit for Minor Work as defined by Section 25-310 of the Landmarks Law.

(b) "CNE shall mean Certificate of no Effect as defined by Section 25-306 of the Landmarks Law.

(c) "CofA shall mean Certificate of Appropriateness as defined by Section 25-307 of the Landmarks Law.

Public thoroughfare. "Public thoroughfare" shall mean any publicly accessible right of way including, but not limited to a street, sidewalk, public park, and path.

Rooftop addition. "Rooftop addition" shall mean a construction or an installation of mechanical equipment and/or occupiable space situated on any structure's roof.

Significant architectural feature. "Significant architectural feature" shall mean an architectural component of a building that contributes to its special historic, cultural and aesthetic character, or that in the case of an historic district reinforces the special characteristics for which the district was designated.

Terms not otherwise defined in this section shall have the meaning given them in the Landmarks Law.

(b) Applications for proposed work. Each application filed with the Landmarks Preservation Commission for proposed construction of a rooftop addition shall be accompanied by:

- (1) documentation, including photographs, which accurately depicts the site of a proposed rooftop addition; and
- (2) sight line studies for the purpose of determining the visibility of the rooftop addition from a public thoroughfare including the point of maximum visibility (see supplementary instructions for filing for rooftop additions); and
- (3) mechanical equipment with respect to any application for rooftop additions for occupiable space, a current objections sheet from the Department of Buildings.

(c) Rooftop additions to be constructed on a structure which is an individual landmark.

(1) The Landmarks Preservation Commission shall issue a CNE for any rooftop addition to be constructed on a structure which is an individual landmark of six stories or less in height which:

- (i) consists solely of mechanical equipment; and
- (ii) does not result in damage to, or demolition of, a significant architectural feature of the roof of the structure on which such rooftop addition is to be constructed; and
- (iii) is not visible from a public thoroughfare.

(2) The Landmarks Preservation Commission shall issue a CNE for any rooftop addition

to be constructed on a structure which is an individual landmark of seven stories or greater in height which:

- (i) consists solely of mechanical equipment; and
- (ii) does not result in damage to, or demolition of, a significant architectural feature of the roof of the structure on which such rooftop addition is to be constructed; and
- (iii) is either not visible from a public thoroughfare or is only minimally visible from a public thoroughfare.

(d) Occupiable space rooftop additions to be constructed on a structure which is an individual landmark.

(1) The Landmarks Preservation Commission shall issue a CNE for any rooftop addition to be constructed on a structure which is an individual landmark which:

- (i) consists of occupiable space; and
- (ii) does not result in damage to, or demolition of, a significant architectural feature of the roof of the structure on which such rooftop addition is to be constructed; and
- (iii) is not visible from a public thoroughfare; and
- (iv) has no outstanding objection for use or bulk listed on the objections sheet for such structure.

(e) Rooftop additions to be constructed on any structure within a designated historic district, other than an individual landmark.

(1) The Landmarks Preservation Commission shall issue a CNE for any rooftop addition to be constructed on any structure within a designated historic district, other than an individual landmark, which:

- (i) consists solely of mechanical equipment; and
- (ii) does not result in damage to, or demolition of, a significant architectural feature of the roof of the structure on which the rooftop addition or installation is to be constructed; and
- (iii) is either not visible from a public thoroughfare or is only minimally visible from a public thoroughfare
- (iv) does not adversely affect significant architectural features of adjacent improvements.

(2) The Landmarks Preservation Commission shall issue a CNE for any rooftop addition to be constructed on any structure within a designated historic district, other than an individual landmark, which:

- (i) consists of occupiable space; and
- (ii) does not result in any damage to, or demolition of, a significant architectural feature of the roof of the structure on which it is constructed; and
- (iii) is not visible from a public thoroughfare; and
- (iv) does not adversely affect significant architectural features of adjacent improvements; and
- (v) has no outstanding objection for use or bulk listed on the objections sheet for such structure.

(f) The Landmarks Preservation Commission shall consider any application for a proposed rooftop addition that does not meet the criteria for a CNE set forth above as a request for a CofA and shall hold a public hearing on such application.

(g) Applicability. (1) This shall not be construed to apply to telecommunications equipment or conventional television antennas.

(h) Application Procedure. (1) All applications received by the Landmarks Preservation Commission will be docketed and reviewed for completeness. The applicant will be notified if additional documentation is required.

(2) When the application is complete, a staff member will review the application for conformance with these rules. Upon determination that the criteria of the rules have been met, a CNE will be issued.

(3) If the criteria for a CNE have not been met, the applicant will be given the opportunity to pursue a Certificate of Appropriateness and may request a meeting with the Director of Preservation to discuss the interpretation of the rules. The applicant may also request a meeting and review by the Chair of the Commission.

(4) The decision of whether to approve an application for a Certificate of Appropriateness is made by an affirmative vote of at least six commissioners following a public hearing.

ROOFTOP ADDITIONS SUPPLEMENTARY INSTRUCTIONS

These are supplementary instructions to the Commissions “Rules Relative to Proposed Construction of Rooftop Additions”, Title 63, 2-19, Subchapter B

In order to judge the appropriateness of proposed rooftop additions to individual landmarks and buildings in historic districts, the Landmarks Preservation Commission must understand the relationship of the addition to the design of the landmark, the surrounding buildings, and the historic district; as well as the effect of the addition on the significant features of the building. To show this, the applicant should complete these four steps:

Step 1 – Prepare Photographs of building and blockfront

Provide 8”x10” photographs of the building and overall views of both sides of the street, in order to illustrate the condition of the building, and the pedestrian eye-level view of what is visible on the roof of the building and the adjoining buildings.

Step 2 – Prepare Drawings of the Building

Provide drawings of the building to show the existing conditions; and the scale, form, details, and materials of the proposed addition. Typical drawings include:

- Floor Plan
- Roof Plan
- Front (street), rear, and side elevations
- Building Section
- Exterior Wall Section

Step 3 – Prepare a Mock-up

Construct a wood or light-gauge steel frame mock-up, matching the overall size and outline of the proposed addition, and set up a meeting with LPC staff to inspect the mock-up. The mock-up should include any railings which might be required at the roof of the addition, as well as at the perimeter of the building. The applicant should also determine if adjoining chimneys will need to be raised, and if so, include these in the mock-up as well (Please note: the mock-up may need to remain in place for a month or more). Provide 8”x10” photographs of the mock-up taken from the street, *wherever the mock-up can be seen*. Applicants are encouraged to paint the mock-up framing, or use brightly colored construction safety netting, so that it is easy to see in the photographs.



Step 4 – Prepare a Rendering with the Proposed Addition

Using photographs of the mock-up, illustrate the building and the blockfront with the addition, as they would actually appear to a person on the sidewalk. Computer generated renderings, or rendered photomontages – which are photographs with the addition drawn in – can be used. *Do not re-draw the entire building or surrounding buildings, instead, just draw in or superimpose the addition.* The view points selected will depend on the site conditions for each project, but should typically include at least the following:

- Point at which the addition first becomes visible
- Point at which the addition is most visible

Indicate these viewpoints on a block plan. View points should always be taken from an eye level 6 feet off the ground, as if by a 6’-4” tall person.



Is a Mock-up Always Necessary?

You may be able to skip this step if you are only proposing to install small HVAC units, skylights, or vent; if you are proposing a very large addition – more than 2 or 3 stories, or when directed by the staff.

2-20 BRACKET SIGNS IN THE TRIBECA EAST, TRIBECA WEST, TRIBECA NORTH, TRIBECA SOUTH, SOHO CAST-IRON, NOHO, AND LADIES' MILE HISTORIC DISTRICTS. (Effective: 6/22/01)

a. Introduction. The large commercial buildings that substantially define the character of the Tribeca East, Tribeca West, Tribeca North, Tribeca South, SoHo Cast-Iron, NoHo, and Ladies' Mile Historic Districts historically had a wide variety of signage, including rigid projecting signs. These signs, known as "bracket signs" extended out perpendicularly from the building face and typically had signage on both sides of the sign.

b. Definitions. As used in this subsection 2-20, the following words shall have the following meanings:

"Armature" shall mean a metal structural support for a rigid projecting sign. The armature may support the bracket sign by means of one or two projecting arms.

"Bracket Sign" shall mean a rigid outdoor sign, with two display faces, installed perpendicular to a building facade and hanging from an armature, used as an announcement for an establishment in the building, consisting of the rigid display faces and all letters, words, numerals, illustrations, decorations, trade marks, emblems, symbols or their figures or characters associated with the name of the establishment that are applied to the faces. In addition, a bracket sign may consist solely of an outline of a shape and/or letters intended to act as a symbol or sign for the establishment.

"CNE" shall mean a Certificate of No Effect as defined by section 25-306 of the New York City Administrative Code.

"Establishment" shall mean a manufacturing, commercial or retail business or profession.

"Facade" shall mean an entire exterior face of a building.

"LPC" shall mean the Landmarks Preservation Commission.

"LPC staff" shall mean the staff of the Landmarks Preservation Commission acting in the Commission's agency capacity.

c. Installation of Bracket Signs. The LPC staff shall issue a CNE for a bracket sign if the proposed work meets all of the following criteria:

1. The armature shall be installed below the second story within the storefront opening or on the flat face of a plain masonry pier and shall be mechanically fastened into the storefront infill or into the mortar joints of a plain masonry pier,

and such installation shall neither damage nor conceal any significant architectural features of the building.

2. The armature shall be a dark finished metal and shall be simply designed.
3. The display faces of the bracket sign may be made of wood or metal. If the bracket sign has display faces, the letters, words, numerals, illustrations or graphics, etc. may be painted or applied onto the display faces, and may be raised slightly from the surface. The overall width, as measured from face to face, shall not exceed 2 inches, and, if there are raised letters, illustrations, etc. the bracket sign shall not exceed a width of three inches as measured from the outside plane of such raised letters or illustrations. The display faces and the letters, words, numerals, illustrations or graphics, etc. shall be of a color or colors that do not detract from the significant architectural features of the building or neighboring buildings. No neon or other vividly bright colors shall be permitted.
4. The bracket sign shall not be internally illuminated, nor shall such sign have neon or L.E.D. (Light Emitting Diode) lighting of any kind, nor shall any lighting fixture or mechanism be attached to the armature.
5. The bracket sign may be fixed or may move freely from its points of attachment to the armature, but in no event shall the bracket sign be made to move by mechanized or controlled means.
6. Number of bracket signs for ground floor establishments.
 - i. Except for signs subject to subsection iii below, one bracket sign per ground floor establishment shall be permitted.
 - ii. In buildings with more than one ground floor establishment, one sign per establishment may be installed, provided that there is no more than one sign per 25 feet of building facade fronting on a street, and further provided that the size, design, placement, materials and details of all of the armatures match. The placement of the bracket sign on the building shall be in close proximity to the establishment that is identified on the bracket sign.
 - iii. A ground floor establishment with a corner storefront may have one bracket sign on each building facade with at least 25 feet of street frontage, provided that each facade has a primary entrance and each bracket sign is located in close proximity to an entrance, but in no event shall more than one bracket sign be located within 20 feet of the corner of the building.
7. Bracket signs for upper story establishments. A single armature for a bracket sign for an upper story establishment or establishments may be installed adjacent to the building entrance for such upper story establishments. This armature may

hold one sign for each upper story establishment, provided such signs hang vertically underneath one another on the same armature, and further provided that in no event shall the total dimensions of such signs, taken together, exceed the size requirements specified in c.8. below.

8. The size of the bracket sign shall conform to the requirements of the Zoning Resolution, but in no event shall the size exceed 24 inches by 36 inches, oriented horizontally or vertically. Novelty shapes, such as circles, polygons and irregular shapes, may be permitted provided such shapes fall within the above dimensions.
9. The projection of the bracket sign and armature beyond the property line shall conform to the requirements of the Zoning Resolution and Building Code, but in no event shall extend more than 40 inches from the facade.
10. The bracket sign shall be installed so that the lowest portion of the sign is at least ten (10) feet above the sidewalk.
11. The establishment seeking approval for a bracket sign shall not, for the same building, already be utilizing an LPC-approved, grandfathered or unapproved flagpole and banner, nor shall it have approval from the LPC for installing a new flagpole and banner on the same building.
12. In approving an application for a bracket sign, the staff shall consider the overall amount of staff and Commission approved signage for the storefront. If the staff determines that the overall amount of signage with the proposed bracket sign is excessive and will detract from the architectural features of the building, the staff shall require that other types of existing or proposed staff approved or approvable signage, including but not limited to signs on awning skirts and signage applied to the storefront glazing, be eliminated or reduced.
13. The application is to install the bracket sign on a building designed as a commercial or loft building and zoned for commercial use and located within the Tribeca East, Tribeca West, Tribeca North, Tribeca South, SoHo Cast-Iron, NoHo, and Ladies' Mile Historic Districts.

SUBCHAPTER C: EXPEDITED REVIEW OF CERTAIN APPLICATIONS FOR CERTIFICATES OF NO EFFECT

2-31 DEFINITIONS

2-32 EXPEDITED REVIEW PROCEDURES

2-33 EFFECT OF FAILURE TO MEET CONDITIONS FOR AN EXPEDITED REVIEW

2-34 REMEDIES FOR FALSE STATEMENTS AND PROCEDURES FOR ACTION

2-35 MISCELLANEOUS

2-31 DEFINITIONS. As used in these Rules, the following terms shall have the following meanings:

Architect. "Architect" shall mean individual, partnership, corporation or other legal entity licensed to practice the profession of architecture under the education law of the State of New York.

CNE. "CNE" shall mean Certificate of No Effect as defined by Section 25-306 of the Landmarks Law.

Day. "Day" shall mean any day other than a Saturday or Sunday or legal holiday.

Engineer. "Engineer" shall mean any individual, partnership, corporation or other legal entity licensed to practice the profession of engineering under the education law of the State of New York.

Landmarks Law. "Landmarks Law" shall refer to New York City Charter Section 3020 and Chapter 3 of Title 25 of the Administrative Code of the City of New York.

Landmarks Preservation Commission. "Landmarks Preservation Commission" shall mean the Commission acting in its agency capacity to implement the Landmarks Law.

Notice of violation. "Notice of violation" shall mean a notice from the Landmarks Preservation Commission that work on a landmark site or within an historic district was performed without a permit or was not performed in accordance with a permit issued by the Landmarks Preservation Commission.

Story. "Story" shall be defined as a habitable floor level, including a basement but not including a cellar.

Terms not otherwise defined in these Rules shall have the meaning given them in the Landmarks Law.

2-32 EXPEDITED REVIEW PROCEDURES

(a) General. An applicant may request that an application for interior work above the second story on any landmark or building within an historic district, other than an application for interior work on a part of the building which has been designated an interior landmark, be reviewed on an expedited basis. Expedited review is predicated upon the statements and representations of the architect or engineer and the owner and upon the satisfaction of certain terms and conditions, all as set forth in this Section 2-32.

(b) Work Eligible for Expedited Review. Interior work which is to be performed above the second story and which does not involve any change to, replacement of, or penetration of, an exterior wall, window, skylight or roof, including but not limited to penetrations, replacements or changes for ducts, grilles, exhaust intakes, vents or pipes, may qualify for an expedited review.

(c) Conditions to Expedited Review. Each of the following conditions must be satisfied in order to obtain an expedited review:

- (1) The work shall be eligible work as described in Subsection 2-32(b) above.
- (2) The application for which an expedited review is requested shall be accompanied by a completed Landmarks Preservation Commission expedited review form which shall include:

(i) a statement signed and sealed by the architect or engineer that:

(A) the architect or engineer has prepared, or supervised the preparation of, the plans and specifications submitted with the application;

(B) all work shown on such plans and specifications is:

- (a) interior work only,
- (b) to be performed only above the second story,
- (c) not to be performed on any portion of a space designated as an interior landmark, and
- (d) does not involve any change to, replacement of, or penetration of, a window, skylight, exterior wall or roof or any portion thereof; and
- (e) for floors 3-6 does not involve a dropped ceiling or a partition which is less than a minimum of 1'-0" back from interior window sill or frame whichever is further from the glass.

(C) that where there are associate architects or engineers, that they likewise join in the request for an expedited review of the application;

(D) that the architect or engineer and associate architects or engineers, if any, are aware that the Landmarks Preservation Commission will rely upon the truth and accuracy of the statements contained in the application made by them, and any amendments submitted in connection therewith, as to compliance with the provisions of the Landmarks Law and these rules;

(ii) a sworn statement executed by the owner of the property that:

(A) the proposed work described is of the type described in Subsection 2-32(b);

(B) no change to, or modification of, the proposed work shall be undertaken by the owner, his or her architect or engineer or any other agent of the owner without the prior approval of the Landmarks Preservation Commission; and

(C) the necessary remedial measures to obtain compliance will be taken, if the same becomes necessary;

(3) No "Notice of Violation" from the Landmarks Preservation Commission shall be in effect against the property which is the subject of the proposed work for which an expedited review is requested; and

(4) The application is complete in all other respects.

(5) The architect or engineer and associate architects or engineers, if applicable, have not been excluded by:

(i) the Chair of the Landmarks Preservation Commission from the procedures for expedited review pursuant to Section 2-34 of these rules; or

(ii) the Commissioner of the Department of Buildings from the Department's procedures for limited supervisory check of applications and plans set forth in 1 RCNY Section 21-02.

(d) Issuance of Permit. If all conditions to an expedited review have been satisfied, the Landmarks Preservation Commission shall:

(1) issue a CNE to the applicant; and

(2) shall perforate all drawings accompanying such application to indicate approval thereof.

2-33 EFFECT OF FAILURE TO MEET CONDITIONS FOR AN EXPEDITED REVIEW.

The Landmarks Preservation Commission shall notify any applicant who has requested an expedited review of his or her application under these rules of the reason for their failure to satisfy the conditions for expedited review.

2-34 REMEDIES FOR FALSE STATEMENTS AND PROCEDURES FOR ACTION.

(a) Grounds for Action. (1) The Chair of the Landmarks Preservation Commission may exclude any

architect or engineer from the procedures for expedited review of applications if the Chair of the Landmarks Preservation Commission finds that:

(i) In connection with the Landmarks Preservation Commission expedited review form described in Section 2-32(c)(1) of these rules the architect or engineer has:

- (A) knowingly or negligently made any false or misleading statement; or
- (B) knowingly or negligently omitted a statement or failed to state a material fact; or
- (C) knowingly or negligently falsified or allowed to be falsified any fact; or
- (D) willfully induced another person to do any of the above; or

(ii) A "Notice of Violation" or "Notice to Stop Work" has been issued by the Landmarks Preservation Commission against work performed pursuant to any plans, prepared by or under the supervision of such architect or engineer, and such Architect or Engineer knew, or had reason to know, that the work performed pursuant to such application, plan, certification, or report was not carried out in accordance with approved plans or exceeded the scope of such approved plans and such architect or engineer failed to act to stop such work and/or to correct such work.

(2) The powers, rights and remedies of the Landmarks Preservation Commission set forth in this Subsection 2-34(a) are non-exclusive and shall not be deemed to limit or supersede any other power, right or remedy of the Landmarks Preservation Commission.

(b) Procedures. (1) Written notice of a preliminary determination, together with the basis for such action to exclude from expedited review shall be served on the architect or engineer of record pursuant to the provisions of New York State Civil Practice Law and Rules Section 308.

(2) The architect or engineer notified under Subsection 2-34(b)(1) shall be entitled to, and scheduled for, a hearing on the preliminary determination in accordance with Subsection 2-34(c) if written objection to the preliminary determination and the grounds for such objection are submitted to the Chair of the Landmarks Preservation Commission within fifteen (15) Days after the date that the notice of preliminary determination is served.

(3) If no hearing is requested pursuant to Subsection 2-34(b)(2) above, the preliminary determination of the Chair of the Landmarks Preservation Commission shall be deemed confirmed and shall become final and effective on the sixteenth (16) Day after the preliminary notice of determination is served.

(4) If after a hearing in accordance with Subsection 2-34(c), the Chair of the Landmarks Preservation Commission confirms the preliminary determination, the Chair shall notify the architect or engineer of such decision and such notice shall include a written statement indicating the reason for his or her determination.

(5) On or after the effective date of the final determination to exclude an architect or engineer from participation in expedited review procedures all of the plans prepared by or under the supervision of such architect or engineer shall be subject to full review by the Landmarks Preservation Commission.

(c) Hearing. (1) Any hearing described in 2-34(b)(2) will be held at, and conducted by, the Office of Administrative Trials and Hearings in accordance with their rules and procedures.

(2) The architect or engineer may be represented by counsel and may present evidence in his or her behalf. A transcribed or tape-recorded record shall be kept of the hearing.

(3) The Chair of the Landmarks Preservation Commission shall notify the respondent of the final determination within ten (10) Days after the receipt of the findings of fact from the Office of Administrative Trials and Hearings on such matters. The determination of the Landmarks Preservation Commission shall be supported by substantial evidence.

(d) Review of Determination. At the expiration of two (2) years from the date of the initial determination to exclude an architect or engineer from participation in the procedures for expedited review of applications, and at intervals of no more than six months thereafter, upon request of the architect or engineer, the Chair of the Landmarks Preservation Commission shall re-examine such determination. If the architect or engineer has not committed any of the acts described in clause (2) of Subsection 2-34(a) above during such period, the Chair of the Landmarks Preservation Commission may rescind such determination.

2-35 MISCELLANEOUS. Any application submitted on or after the effective date hereof shall be subject to these rules.

**APPENDIX A: RESOURCES FOR HISTORIC PHOTOGRAPHS
& DRAWINGS**

ADDRESS: _____
BOROUGH: _____ BLOCK: _____ LOT: _____

ALL APPLICANTS (OR THEIR DESIGNATED REPRESENTATIVES) MUST CHECK FOR HISTORIC PHOTOGRAPHS AND DRAWINGS AT THE MUNICIPAL ARCHIVES, 31 CHAMBERS STREET, SUITE 103, NEW YORK, NEW YORK. (212)-788-8580.

DATE CHECKED: _____

IN ADDITION, APPLICANTS MUST CHECK THE OTHER RESOURCES LISTED FOR THE APPLICABLE BOROUGH BELOW:

Brooklyn:

Department of Buildings- Municipal Building, 208-42 Joralemon Street, 8th Floor (718) 802-3675.

DATE CHECKED: _____

New York Public Library - 5th Avenue and 42nd Street (212) 930-0800

DATE CHECKED: _____

Brooklyn Historical Society - 128 Pierrepont Street (718) 624-0890

DATE CHECKED: _____

Bronx:

Department of Buildings - 1932 Arthur Avenue, 8th Floor (718) 579-6982

DATE CHECKED: _____

New-York Historical Society - 170 Central Park West, Manhattan (212) 873-3400

DATE CHECKED: _____

Manhattan:

Department of Buildings - 280 Broadway, 5th Floor (212) 566-5000

DATE CHECKED: _____

New-York Historical Society - 170 Central Park West (212) 873-3400

DATE CHECKED: _____

New York Public Library - 5th Avenue & 42nd Street (212) 930-0800

DATE CHECKED: _____

Queens:

Department of Buildings - 120-55 Queens Boulevard, Kew Gardens (718) 520-3415

DATE CHECKED: _____

Queens Borough Public Library - 89-11 Merrick Boulevard, Jamaica (718) 990-0770

DATE CHECKED: _____

Staten Island:

Department of Buildings - Borough Hall, 10 Richmond Terrace (718) 816-2312

DATE CHECKED: _____

Staten Island Institute of Arts & Sciences - 75 Stuyvesant Place (718) 727-1135

DATE CHECKED: _____

I certify that I have searched for historic photographs and/or drawings of the subject premises at the resources which are relevant to the subject premises, and that I was unable to locate any historic photographs or drawings of the premises.

APPLICANT: _____

SIGNATURE: _____

CHAPTER 3: REPAIR AND REPLACEMENT OF WINDOWS IN LANDMARK AND HISTORIC DISTRICT BUILDINGS (WINDOW GUIDELINES) (Amended 8/2/02)

3-01 INTRODUCTION

3-02 REPAIRS, REHABILITATION AND RESTORATION

3-03 STORM WINDOWS

3-04 REPLACEMENT OF SASH AND FRAMES

3-05 MASTER PLANS

3-06 APPLICATION PROCEDURE

3-07 PRE-QUALIFIED OPEN MARKET MANUFACTURED WINDOWS

3-01 INTRODUCTION.

(a) These rules are issued to assist the public in applying to the Landmarks Preservation Commission for approval of repair, rehabilitation, restoration or replacement of windows in buildings that are designated landmarks or are within designated historic districts. These rules, which hereinafter will be referred to as "guidelines," enunciate Commission policy with respect to such repair, rehabilitation, restoration or replacement and also explain the procedures required to apply for a permit.

(b) Windows are an important and integral part of the design of most buildings. They typically comprise 30% to 40% of the surface area of a building's principal facade. In most historic buildings the window sash, window framing, and the architectural detail surrounding the windows were carefully designed as an integral component of the style, scale and character of the building. It is important to retain the configuration, operation, details material and finish of the original window as well as to maintain the size of openings, sills, decorative moldings, and the sash itself.

(c) Therefore, the Commission, in making a determination on proposed repair, rehabilitation, restoration or replacement of windows, evaluates the effect of the proposal on the aesthetic, historical and architectural values and significance of the landmark or of the building in an historic district. The Commission considers, among other matters, the architectural style of the building and the design, texture, material and color of the proposed work.

(d) These window guidelines are based on the following principles:

(1) The distinguishing original qualities or character of a building's structure, or site and its environment, should not be destroyed. The removal or alteration of any distinctive architectural feature should be avoided whenever possible.

(2) Deteriorated architectural features including windows should be repaired rather than replaced whenever possible.

(3) If replacement is necessary, the new window should match the original or historic window in design and other visual qualities.

3-02 REPAIRS, REHABILITATION AND RESTORATION.

(a) Repairs. Deteriorated windows can often be repaired and made sound and fully operational. A permit is not required to undertake ordinary repairs including:

(1) Replacement of broken glass, together with replacement of associated moldings, muntins and glazing compound with material of matching characteristics.

(2) Scraping, priming and repainting of window sash and/or frame to recoat with same color and finish that exist at the time such work is undertaken.

(3) Caulking around frames and sill.

(4) Repair and replacement of window hardware, including pulley chains.

(5) Installation of weatherstripping.

(6) Straightening of metal window members.

(7) Rebuilding of portions of sills, sash and other window members, using the same material and to the same configuration, size and shape, limited to the following:

(i) up to 100% for sills, bottom sash rails and parting strips;

(ii) up to 40%, measured separately, for trim, moldings and other sash members.

(8) Consolidating wood members.

(b) Rehabilitation and restoration. A permit is required for:

(1) work that does not meet the requirements of subsection (a) above;

(2) changes in configuration; or

(3) any change in the shape and size of any member.

3-03 STORM WINDOWS. (a) The installation of secondary glazing units ("storm windows"), either interior or exterior, will be allowed under the following conditions:

(1) A permit is not required for installation of interior storm windows provided that:

(i) The installation has no mullions, muntins or wide frames that are visible from the exterior of the building; and

(ii) The glazing consists of clear glass or other transparent material. If these conditions are not met a permit will be required.

(2) A permit is required for installation of exterior storm windows.

(b) Exterior storm windows shall fit tightly within window openings without the need for subframe or panning around the perimeter. The color of frames of exterior storm windows shall match the color of the primary window frame. Clear glass only will be permitted. The storm sash shall be set as far back from the plane of the exterior wall surface as practicable. Muntins shall not be permitted. Meeting rails may be used only in conjunction with double-hung windows and shall be placed in the same relative location as in the primary sash.

3-04 REPLACEMENT OF SASH AND FRAMES. (As amended 8/2/02) If the windows have deteriorated to a condition that warrants replacement, new windows will be permitted under the following conditions:

(a) A permit is required for the installation of new sash in existing frames. In cases where the sash is deteriorated to a point precluding reasonable repair, rehabilitation or restoration, replacement sash may be installed subject to the issuance of a permit. In determining whether sash cannot be repaired, the Landmarks Preservation Commission will consider the percentage of the window that is deteriorated, the practicality of repair, trade practice and such other factors as the LPC may deem appropriate. The new sash shall match the existing sash in dimensions, configuration, operation, details, material, and finish except as provided below. If the rehabilitation of frames is required in conjunction with an application for new sash, that work shall be part of the application.

(b) A permit is required for the installation of new sash and frames in landmarks and buildings in historic districts.

(c) New sash and frames in primary facades:

(1) Individual landmarks:

(i) If historic windows have deteriorated to a point precluding reasonable repair, rehabilitation or restoration, based on a condition report submitted by the applicant, or a field inspection by the staff, or other evidence, including the percentage of the window that is deteriorated, the practicality of repair, trade practice and other factors, replacement windows may be approved if they match the historic windows in terms of:

(A) configuration,

(B) operation,

- (C) details,
- (D) material, and
- (E) finish.

(ii) Variations in details will be permitted if such variations do not significantly affect the visual characteristics of the window, including the shadow effect of muntins and sash on the glazing. In evaluating "significant" effect, factors to be considered shall be the age of the building and its architectural quality, as well as the extent of diminution in the total glazed area of sash. For wood windows less than 15 inches wide, the diminution shall be limited to 10%; for wood windows 15 inches or wider, the diminution shall be limited to 6%; for metal windows (of any size) the diminution shall be limited to 10%.

(iii) With respect to matching of materials, the following shall be understood: a wood historic window shall be replaced in wood, but not necessarily of the same species. A metal historic window shall be replaced with metal but not necessarily of the same metal.

(2) Buildings in historic districts.

(i) Rowhouses, town houses, mansions, detached and semi-detached houses and carriage houses:

(A) If historic windows have deteriorated to a point precluding reasonable repair, rehabilitation or restoration, based on a condition report submitted by the applicant, or a field inspection by the staff, or other evidence, including the percentage of the window that is deteriorated, the practicability of repair, trade practice and other factors, replacement windows may be approved if they match the historic windows in terms of:

- (a) configuration,
- (b) operation,
- (c) details,
- (d) material, and
- (e) finish,

except that straight-headed, double-hung, one-over-one sash may be replaced by sash with a different material, provided the historic brickmolds are preserved, restored or, if necessary replicated in the historic material, the new sash is installed in the same plane as the historic sash, and the sash and brickmolds have a matching finish that replicates the historic finish.

(B) Variations in details will be permitted if such variations do not significantly affect the visual characteristics of the window, including the

shadow effect of muntins and sash on the glazing. In evaluating "significant" effect, factors to be considered shall be the age of the building and its architectural quality, as well as the extent of diminution in the total glazed area of sash. For wood windows less than 15 inches wide, the diminution shall be limited to 10%; for wood windows 15 inches or wider, the diminution shall be limited to 6%; for metal windows (of any size) the diminution shall be limited to 10%.

(C) With respect to matching of materials, the following shall be understood: a wood historic window shall be replaced in wood, but not necessarily of the same species. A metal historic window shall be replaced with metal but not necessarily of the same metal.

(ii) Small apartment buildings, tenements and hotels:

(A) In small apartment buildings and other types of multiple dwellings, originally built as such, which are six stories or less in height, and with a street frontage of forty (40) feet or less, replacement windows may be approved if they match the historic windows in terms of:

- (a) configuration,
- (b) operation,
- (c) details,
- (d) material, and
- (e) finish,

except that straight-headed, double-hung, one-over-one sash may be replaced by sash with a different material, provided the historic brickmolds are preserved, restored or, if necessary replicated in the historic material, the new sash is installed in the same plane as the historic sash, and the sash and brickmolds have a matching finish that replicates the historic finish.

(B) Variations in details will be permitted if such variations do not significantly affect the visual characteristics of the window, including the shadow effect of muntins and sash on the glazing. In evaluating "significant" effect, factors to be considered shall be the age of the building and its architectural quality, as well as the extent of diminution in the total glazed area of sash. For wood windows less than 15 inches wide, the diminution shall be limited to 10%; for wood windows 15 inches or wider, the diminution shall be limited to 6 %; for metal windows (of any size) the diminution shall be limited to 10%.

(C) With respect to matching of materials, the following shall be understood: a wood historic window shall be replaced in wood, but not necessarily of the

same species. A metal historic window shall be replaced with metal but not necessarily of the same metal.

(iii) Large apartment buildings and hotels:

(A) In large apartment buildings and other types of multiple dwellings, which either have a street frontage of forty-one (41) feet or greater, or which are seven or more stories in height, replacement windows may be approved if they match the historic windows in terms of:

- (a) configuration,
- (b) operation,
- (c) details, and
- (d) finish.

(B) Variations in details will be permitted if such variations do not significantly affect the visual characteristics of the window, including the shadow effect of muntins and sash on the glazing. In evaluating "significant" effect, factors to be considered shall be the age of the building and its architectural quality, as well as the extent of diminution in the total glazed area of sash. For wood windows less than 15 inches wide, the diminution shall be limited to 10%; for wood windows 15 inches or wider, the diminution shall be limited to 6%; for metal windows (of any size) the diminution shall be limited to 10%.

(C) Where the historic windows possess special architectural value, including "special" windows (as defined in the definitions (Section 3-01) and illustrated in Appendix A), replacement windows shall match the material of the historic windows.

(iv) Small commercial and loft buildings including cast-iron fronted buildings, department stores, banks and office buildings.

(A) In commercial and loft buildings that are six stories or less in height, and with a street frontage of 40 feet or less, replacement windows may be approved if they match the historic windows in terms of:

- (a) configuration,
- (b) operation,
- (c) details,
- (d) material, and
- (e) finish.

except that straight-headed, double-hung, one-over-one sash may be replaced

by sash with a different material, provided the historic brickmolds are preserved, restored or, if necessary, replicated in the historic material, the new sash is installed in same plane as the historic sash, and the sash and brickmolds have a matching finish that replicates the historic finish.

(B) Variations in details will be permitted if such variations do not significantly affect the visual characteristics of the window, including the shadow effect of muntins and sash on the glazing. In evaluating "significant" effect, factors to be considered shall be the age of the building and its architectural quality, as well as the extent of diminution in the total glazed area of sash. For wood windows less than 15 inches wide, the diminution shall be limited to 10%; for wood windows 15 inches or wider, the diminution shall be limited to 6 %; for metal windows (of any size) the diminution shall be limited to 10%.

(C) With respect to matching of materials, the following shall be understood: a wood historic window shall be replaced in wood, but not necessarily of the same species. A metal historic window shall be replaced with metal but not necessarily of the same metal.

(v) Large commercial and loft buildings, including cast-iron fronted buildings, department stores, banks and office buildings.

(A) In commercial and loft buildings that are seven or more stories in height, or with a street frontage of 41 feet or greater, replacement windows may be approved if they match the historic windows in terms of:

- (a) configuration,
- (b) operation,
- (c) details, and
- (d) finish.

(B) Variations in details will be permitted if such variations do not significantly affect the visual characteristics of the window, including the shadow effect of muntins and sash on the glazing. In evaluating "significant" effect, factors to be considered shall be the age of the building and its architectural quality, as well as the extent of diminution in the total glazed area of sash. For wood windows less than 15 inches wide, the diminution shall be limited to 10%; for wood windows 15 inches or wider, the diminution shall be limited to 6 %; for metal windows (of any size) the diminution shall be limited to 10%.

(C) Where the historic windows possess special architectural value, including "special" windows (as defined in the definitions (Section 3-01) and

illustrated in Appendix A), replacement windows shall match the material of the historic windows.

(3) Other Buildings:

For buildings that do not fall into any of the previously described categories, the finding of appropriateness of window replacements will be made on a case-by-case basis. Variations in design of these specialized buildings preclude the applicability of guidelines.

Such special building types include churches and synagogues, hospitals, schools, libraries and the one- or two-story commercial buildings known as a "taxpayer." Also included in this category are buildings which, unless specifically noted in the text of these guidelines, have been converted from their original use.

(d) New sash and frames in secondary facades. (1) If existing windows are visible from a public thoroughfare, replacement windows may be approved if they match the historic windows in terms of:

- (i) configuration and
- (ii) finish.

(2) If existing windows are not visible from a public thoroughfare, replacement windows may be approved if: (as amended 12/21/99)

- (i) they are to be installed in existing window openings or existing openings that are to be enlarged in height or width, and such enlargement does not alter or destroy protected features; or
- (ii) they are to be installed in existing window openings that are to be reduced in height or width; and
- (iii) they do not replace "special" windows as defined in the definitions (section 3-01) and illustrated in Appendix A.

3-05 MASTER PLANS. (a) A master plan for the repair and/or replacement of windows over a period of time can be approved under a PMW if the plan is in conformance with these guidelines. After the permit is issued, proposed window replacement will require applications requesting an Authorization to Proceed (ATP).

(b) The master plan shall set forth standards for future changes and shall specifically identify such standards by drawings, including large scale details of existing and proposed conditions, plus fenestration and location of proposed changes.

3-06 APPLICATION PROCEDURE.

(a) Application. (1) Application form. An application consists of a completed application form and supporting documentation. The form, "For Work on Designated Properties," must be signed by the owner of the property although the applicant may be the lessee or owner's agent. An application from a cooperative or condominium building must be signed by a properly authorized official of the corporation. The form also requires the name of the occupant, lessee or shareholder who is proposing the alteration as well as the name of the person filing the application (if not the owner).

The application form, "For Work on Designated Properties," is available at the Commission's office at 100 Old Slip, New York, NY 10005 by mail or by calling (212) 487-6800.

(2) Supporting documentation. An application must include photographs, drawings and descriptive material of the existing conditions of the windows and the building. For buildings located in historic districts, photographs of adjacent buildings should also be submitted. In addition, a description of the proposed work, manufacturers' catalogue cuts or drawings with comparative dimensions, details of construction, configuration, color and finish are required. Proposals for metal replacement windows should include material samples.

(b) Procedure. (1) All applications received by the Landmarks Preservation Commission will be docketed and reviewed for completeness. The applicant will be notified if additional documentation is required.

(2) When the application is complete, a staff member will review the application for conformance with these guidelines. Upon determination that the criteria of the guidelines have been met, a PMW will be issued.

(3) If the criteria have not been met, the applicant will be given a notice of the proposed denial of the application and an opportunity to request a meeting with the Director of the Preservation Department, or in the absence of the Director with a Deputy Director, to discuss the interpretation of these guidelines. The applicant may also request a meeting and review by the Chairman.

(4) If the application is denied, the applicant shall be informed of his or her right to file for a Certificate of Appropriateness pursuant to law. The decision of whether to approve an application for a Certificate of Appropriateness is made by an affirmative vote of a least six commissioners following a public hearing.

3-07 PRE-QUALIFIED OPEN MARKET MANUFACTURED WINDOWS. The Landmarks Preservation Commission may from time to time, by additional rule, identify as meeting the requirements of these guidelines various manufactured windows which are available on the open market.

APPENDIX A

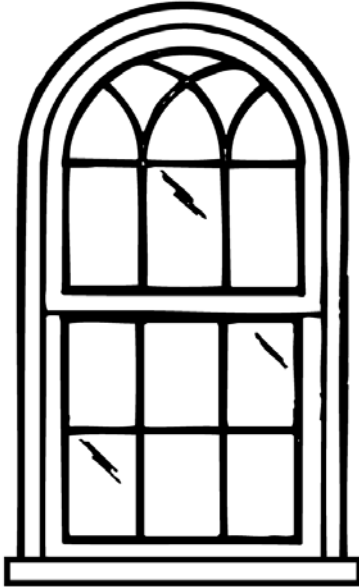

CURVED MUNTINS

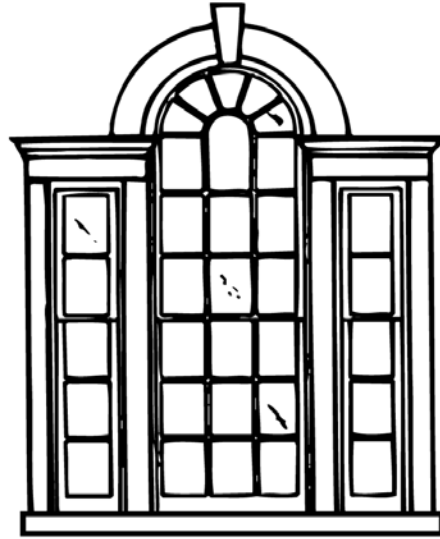

PALLADIAN

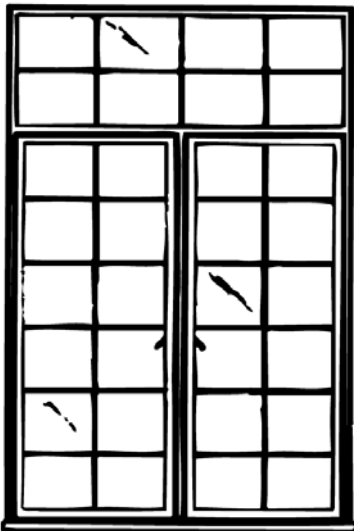

MULTI-LIGHT

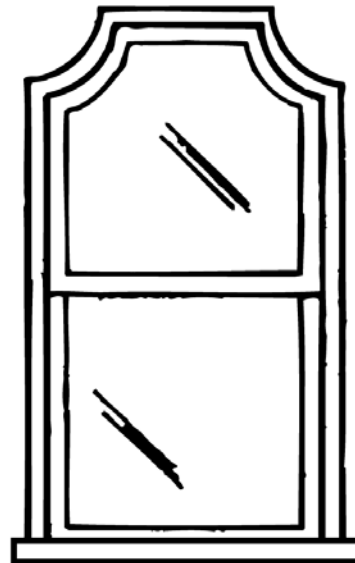

SHOULDERED

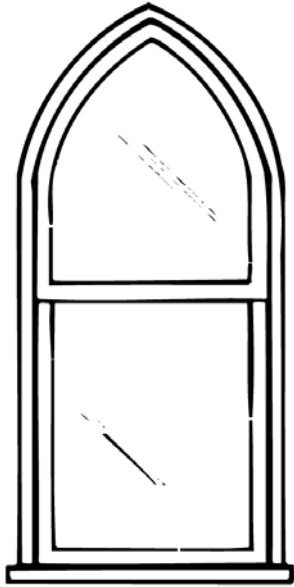

POINTED

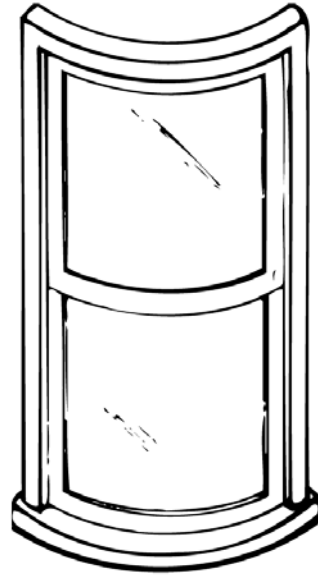

CURVED

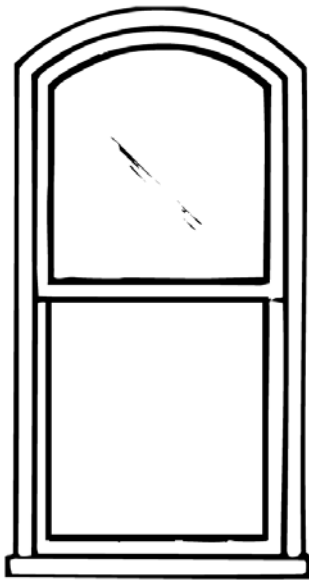

SEGMENTAL

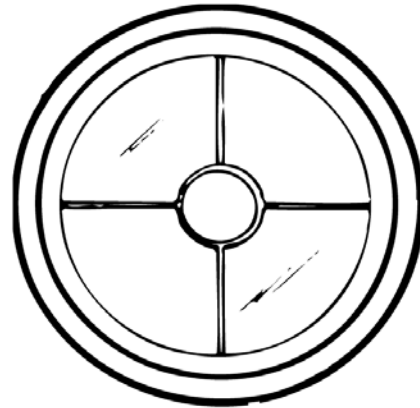

ROUND

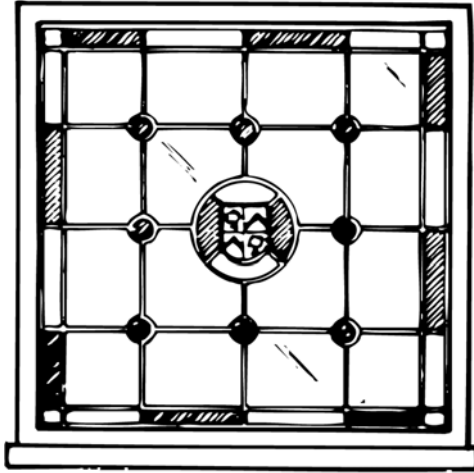

OVAL-STAINED

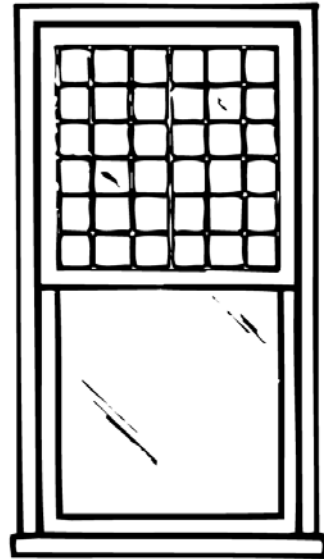

MULTI-LIGHT

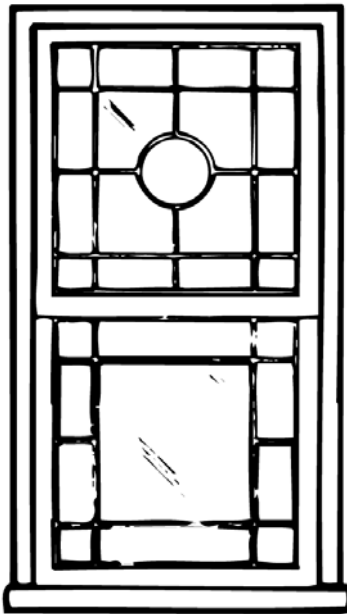

QUEEN ANNE

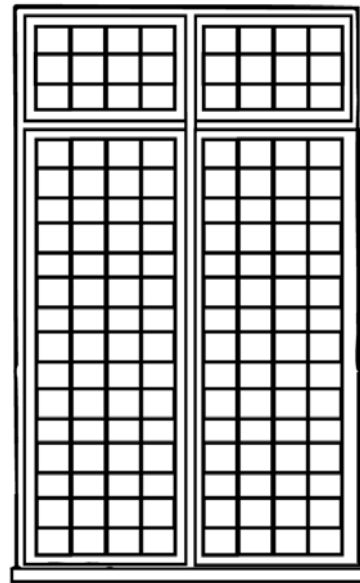

LEADED

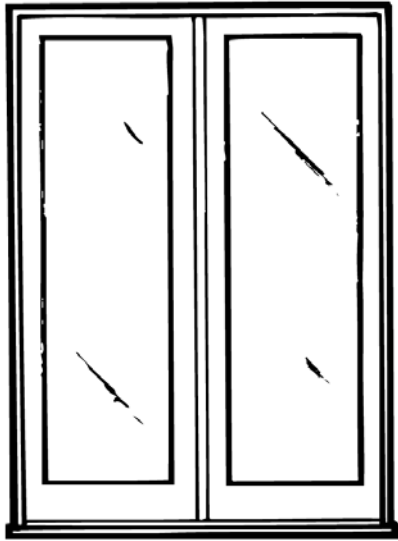

FRENCH DOORS

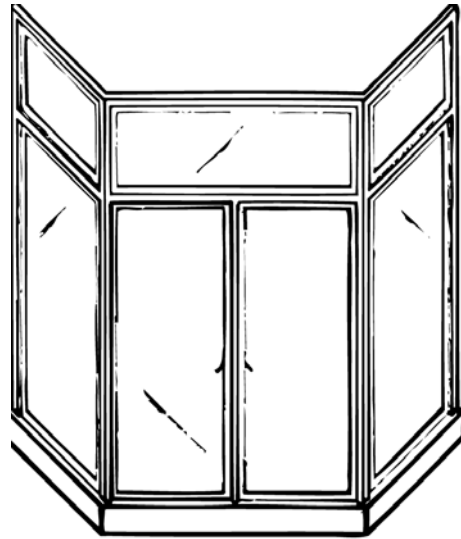

CASEMENT BAYS

APPENDIX B

PARTS OF A DOUBLE-HUNG WINDOW

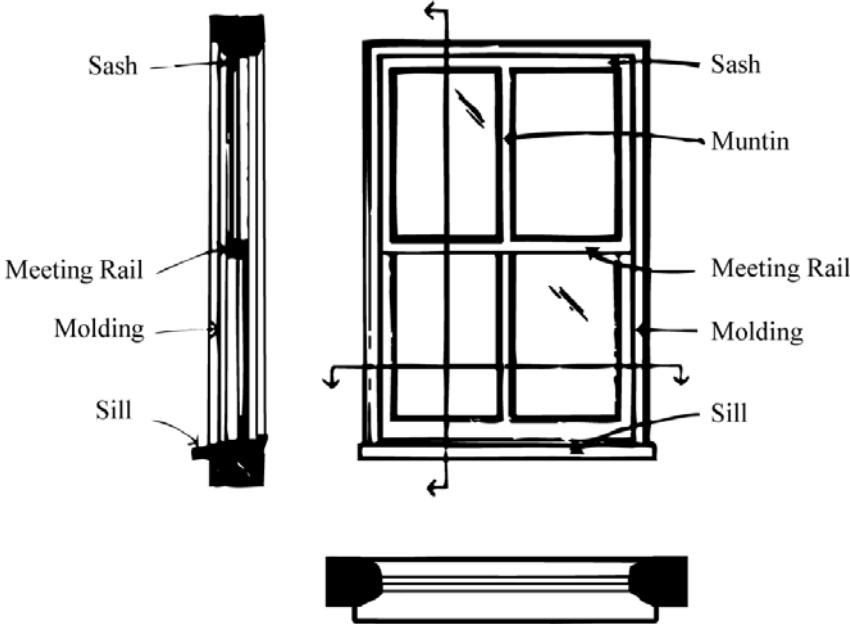

APPENDIX C

Color. "Color" shall mean the sensible perception of hue, value and saturation characteristics of surfaces of window components. In the event of disagreement, the Munsell system of color identification shall govern.

Commission. "Commission" shall mean the Landmarks Preservation Commission as established by Section 3020 of the New York City Charter.

Commissioners. "Commissioners" shall mean the eleven Commissioners, including the Chairman, as established by Section 3020 of the Charter.

Configuration. "Configuration" shall mean the number, shape, organization and relationship of panes (lights) of glass, sash, frame, muntins or tracery.

Details. "Details" shall mean the dimensions and contours of both the stationary and moveable portions of a window, and moldings. Details are shown in graphic form in Appendix B.

Existing Windows. "Existing Windows" shall mean the windows existing at the time of designation or windows which have been changed subsequent to designation pursuant to a permit issued by the Commission.

Fenestration. "Fenestration" shall mean the arrangement, proportioning and design of windows in a building.

Finish. "Finish" shall mean the visual characteristics including color, texture and reflectivity of all exterior materials.

Frame. "Frame" shall mean the stationary portion of a window unit that is affixed to the facade and holds the sash or other operable portions of the windows.

Glazing. "Glazing" shall mean the material, usually glass, that fills spaces between sash members (rails, stiles and muntins), commonly referred to as panes or lights.

Head. "Head" shall mean the upper horizontal part of a window frame or window opening.

Historic windows. "Historic windows" shall mean:

- (1) windows installed at time of construction of the building; or
- (2) windows of a type installed at time of construction of similar buildings in similar periods and styles; or

(3) windows installed at time of major facade alterations 30 or more years ago.

Jamb. "Jamb" shall mean the side parts of a window frame or window opening, as distinct from head and sill.

Landmarks Law. "Landmarks Law" shall be understood to refer to Title 25, Chapter 3 of the Administrative Code of the City of New York.

Light. "Light" shall mean a pane of glass; a window, or a compartment of a window.

LPC. "LPC" shall mean the Commission acting in its agency capacity to implement the landmarks law.

Match. "Match" shall mean either an exact or approximate replication. If not an exact replication, the approximate replication shall be so designed as to achieve a suitable, harmonious and balanced result.

Materials. "Materials" shall mean the substances used to fabricate windows.

Meeting rail. "Meeting rail" shall mean a sash rail in a double-hung window designed to interlock with an adjacent sash rail.

Member. "Member" shall mean a component part of a window.

Molding. "Molding" shall mean a piece of trim that introduces varieties of outline or curved contours in edges or surfaces as on window jambs and heads. Moldings are generally divided into 3 categories: rectilinear, curved and composite-curved.

Mullion. "Mullion" shall mean a vertical primary framing member that separates paired or multiple windows within a single opening.

Muntin. "Muntin" shall mean the tertiary framing member that subdivides the sash into individual panes, light or panels; lead "comes" are often used in stained glass windows.

Note: Grids placed between two sheets of glass are not considered muntins.

Operation. "Operation" shall mean the manner in which a window unit opens, closes, locks, or functions; e.g., casement, double-hung, etc. If non-operable, a window unit (such as a side light) is identified as "fixed."

Panning. "Panning" shall mean an applied material, usually metal, that covers the front (exterior) surface of an existing window frame or mullion.

Parting strip. "Parting strip" shall mean the small member, usually wood and usually removable,

that separates the upper and lower sash pockets in the jamb of a double-hung window.

Permit. "Permit" shall mean any permit issued by the Landmarks Commission, in accordance with the provisions of the landmarks law:

- (1) "PMW" to mean Permit for Minor Work as defined by Section 25-310 of the landmarks law.
- (2) "CNE" to mean Certificate of No Effect as defined by Section 25-306 of the landmarks law.
- (3) "C of A" to mean Certificate of Appropriateness as defined by Section 25-307 of the landmarks law.

Principal facade. "Principal facade" shall mean:

- (1) a facade facing a street or public thoroughfare that is not necessarily a municipally dedicated space, such as a mews or court; or
- (2) a facade that does not face a street or mews or court but that possesses significant architectural features.

Rail. "Rail" shall mean a horizontal sash member.

Rehabilitation. "Rehabilitation" shall mean any repair work that requires a permit. (See 3-02 below.)

Repair. "Repair" shall mean any work done on any window to correct any deterioration or decay of or damage to a window or any part thereof and to restore same, as closely as may be practicable, to its condition prior to the occurrence of such deterioration, decay or damage. The term "ordinary repair" shall refer to work that does not require a permit. (See Section 3-02 below.)

Restoration. "Restoration" shall mean the process of returning, as nearly as possible, a building or any of its parts to its original form and condition.

Sash. "Sash" shall mean the secondary part of a window which holds the glazing in place; may be operable or fixed; usually constructed of horizontal and vertical members; sash may be subdivided with muntins.

Secondary facade. "Secondary facade" shall mean a facade that does not face a public thoroughfare or mews or court and that does not possess significant architectural features.

Significant architectural features. "Significant architectural features" shall mean an architectural component of a building that contributes to its special historic, cultural and aesthetic character, or

that in the case of an historic district reinforces the special characteristics for which the district was designated.

Sill. "Sill" shall mean the lower horizontal part of a window frame or window opening; also the accessory member which extends as a weather barrier from frame to outside face of wall.

Special windows. "Special windows" shall mean:

(1) those windows in which the complexity of the muntin pattern or the molding profiles is one of the characteristics of the style and age of the building; or

(2) windows having one or more of the following or similar attributes, including but not limited to:

(i) Bay or oriel window

(ii) Curved glass

(iii) Multi-pane sash, i.e., 12 or more panes in a single sash in which a typical pane does not exceed 30 square inches of open (glazed) area

(iv) Stained or otherwise crafted glazing for artistic effect

(v) Highly decorated (carved or otherwise embellished) sash or frame

(vi) Non-rectilinear sash or frame.

See Appendix A for illustrations of these and other types of "Special Windows."

Stile. "Stile" shall mean a vertical sash member.

Story. "Story" shall be defined as a habitable floor level including a basement but not including a cellar.

CHAPTER 4: DESIGNATED BROADWAY THEATERS

4-01 TREATMENT OF DESIGNATED BROADWAY THEATER INTERIORS (THEATER INTERIOR GUIDELINES)

4-02 TREATMENT OF DESIGNATED BROADWAY THEATER EXTERIORS (THEATER EXTERIOR GUIDELINES)

4-01 TREATMENT OF DESIGNATED BROADWAY THEATER INTERIORS (THEATER INTERIOR GUIDELINES).

(a) Preface. Work may be done on designated interior portions of theaters either without application to the Commission, or with a Certificate of No Effect on Protected Architectural Features (CNE) if the proposed work is in accordance with the following guidelines:

(1) For production-related work, no application to Landmarks Preservation Commission is needed if the guidelines set forth in 4-01(b)(1) below are followed, but owner must submit a written description to the Landmarks Preservation Commission (LPC), prior to undertaking the work, clearly delineating the scope of the proposed work. This description should also include steps to be taken after the end of the production to return the interior to its prior condition if significant architectural features are proposed to be altered, unless further changes are mandated by an incoming production, in which case the interior would be returned to its prior condition following the latter production.

(2) For permanent alterations, application to LPC is necessary and a CNE will be issued by staff if in accordance with the guidelines set forth in 4-01(b)(2) below.

(3) Applications for work not in accordance with the guidelines will be subject to the usual landmark review procedure as set forth in Chapter 3 of Title 25 of the Administrative Code.

Note: The guidelines are keyed to underlined portions of the Description Section of the Designation Reports, which identify architecturally significant features requiring protection.

(b) Guidelines. (1) Production-related changes. No permit needed for work, if the following conditions are met:

(i) Interior configuration of the theater is maintained.

(ii) Any alteration to architectural features underlined in the Description Section of the Designation Report is reversible. (It should be noted that alterations to certain architectural features may not be reversible; for example, murals or heavily three-dimensional decorative features such as putti.)

(iii) Following a production in which a theater interior is to be painted a non-

contrasting color scheme, the theater interior will be painted in contrasting colors, unless some other color scheme is mandated by the incoming production, in which case the interior would be painted in contrasting colors following the latter production. (A contrasting color scheme is one in which the ornamental architectural details are painted a different color or a different value or hue of the same color than the background.)

(iv) If the Buildings Department requires a permit for the work, a CNE will be issued by staff within five working days of the receipt of a completed application.

(2) Permanent changes. A CNE will be issued by the staff within five working days of receipt of a completed application for alterations to the theater if the following conditions are met:

(i) Interior configuration is maintained.

(ii) Staff has determined that the alteration would not affect significant architectural features underlined in the Description Section of the Designation Report. In theaters which are only designated on the interior, such alterations could include exterior build-overs.

(iii) Any installation of state-of -the-art changes, as certified by the owner, such as light bridges, sound booths, and balcony rail light housings, provided that staff finds that

(A) their installation will have no effect on the physical fabric of the significant architectural features of the interior, or

(B) such effect is reversible and that adequate steps will be taken to assure that affected features can be replaced in the future.

4-02 TREATMENT OF DESIGNATED BROADWAY THEATER EXTERIORS

(THEATER EXTERIOR GUIDELINES). (a) Preface. Work may be done on designated exterior portions of theaters either without application to the Commission, or with a Certificate of No Effect on Protected Architectural Features (CNE) if the proposed work is in accordance with the following guidelines:

(1) For production-related work, no application to LPC is needed if the guidelines set forth in 4-02(b)(1) below are followed, but the owner must submit a written description to the LPC, prior to undertaking the work, clearly delineating the scope of the proposed work. This description should also include steps to be taken after the end of the production to return the exterior to its prior condition if significant architectural features are proposed to be altered.

(2) For permanent alterations, application to LPC is necessary and a CNE will be issued

by staff if in accordance with the guidelines set forth in 4-02(b)(2) below.

(3) Applications for work not in accordance with the guidelines will be subject to the usual landmark review procedure as set forth in Chapter 3 of Title 25 of the Administrative Code.

Note: The guidelines are keyed to underlined portions of the Description Section of the Designation Reports, which identify architecturally significant features requiring protection.

(b) Guidelines. (1) Production-related changes. No permit is needed for the following work, if the stated conditions are met:

(i) The installation of new signage or alteration of existing signage, lighting, or other advertisement, provided that anchorages do not physically affect architectural features underlined in the designation report description. (Changing of light box fillers, posters, photos, etc. would not require review or notice to the Commission.)

(ii) Painting of exterior surfaces, if they were previously painted.

(iii) Alterations or additions to any undeveloped portions of the theater exterior, provided that the protected features of a designated interior are not affected.

(iv) Any alterations to underlined exterior architectural features in the report that are reversible. (A reversible alteration is one in which the altered feature can be returned to its appearance prior to the alteration.)

(v) Removal of any feature which has not been identified in the Description Section of the Designation Report of the theater.

(vi) For theaters in which the exterior is designated only for cultural and historical significance, any alteration to the facade may be made provided that:

(A) Lighted signage and advertisements for productions are utilized.

(B) Continuous entrance doors are maintained between the lobby and the street and the auditorium and the street, where they presently exist.

(C) A marquee is utilized to shelter the sidewalk adjacent to the entrance doors referred to in 4-02(b)(1)(vi)(B).

(2) Permanent Changes. A CNE will be issued by the staff within five working days of receipt of completed application for the following work, if the stated conditions are met.

CHAPTER 5: HISTORIC PRESERVATION GRANT PROGRAM

5-01 INTRODUCTION

5-02 ELIGIBILITY CRITERIA

5-03 APPLICATION REQUIREMENTS AND SELECTION CRITERIA

5-01 INTRODUCTION. The Historic Preservation Grant Program provides grants to eligible nonprofit organizations and homeowners for the preservation of designated landmark properties through restoration, repair and rehabilitation work. All grants must meet the guidelines laid out for historic preservation activities under the federal Community Block Grant program regulation. 24 CFR Sec. 570.202(d).

5-02 GENERAL ELIGIBILITY REQUIREMENTS. In addition to any applicable federal regulations regarding the Community Block Grant Program, grant applicants shall also meet the following criteria: (a) Eligible Structures. Structures which are designated or calendared individual landmarks, are located in designated historic districts, or contain interior landmarks. Eligible structures may also include those improvements located in New York City that are listed or eligible for listing on the National Register. The premises cannot be in arrears for unpaid real estate taxes, water/sewage charges, or have any unrescinded notice of violations issued by the Landmarks Preservation Commission or the Department of Buildings.

(b) Eligible Repairs. Grants shall be made for the following work: (1) to repair and restore exterior features of an eligible structure; (2) to address structural damage or severe deterioration that threatens to undermine the integrity of an eligible of an eligible structure; (3) to repair and restore eligible interiors.

(c) Ownership/Occupancy. (1) Homeowners. Owners of eligible residential properties may receive grant funds if the owner and/or occupants meet Section 8 income limits as they appear in the federal Community Block Grant Program regulations. 24 CFR Sec. 570.208(a)(2)(i)(B) and (C).

(2) Nonprofit Organizations. (i) Nonprofit organizations applying for grant funds must either own or hold a long term lease on the property for which funds are sought.

(ii) To be eligible for consideration as a nonprofit organization, the applicant must be a charitable, cultural, educational, scientific, literary, or other entity organized under section 501 (c)(3) of the Internal Revenue Code.

(d) Grant Beneficiaries. All grant-funded work must (1) principally benefit low and moderate income persons or (2) address slum and blight conditions as set forth in and defined under the federal Community Block Grant Program regulations. 24 CFR Sec.570.208.

5-03 APPLICATION REQUIREMENTS AND SELECTION CRITERIA. (a) Grant

applications will be evaluated and funds will be awarded by a board composed of the director of the Historic Preservation Grant Program and other staff members of the Landmarks Preservation Commissions as the Chairman shall in his or her discretion appoint.

(b) In awarding grants, the Historic Preservation Grant Program board will give preference to properties designated or calendared by the Landmarks Preservation Commission and will consider the following factors, among others:

- (1) the architectural and historical importance of the building; and
- (2) the condition of the building and the degree to which the proposed work will materially address the building's condition; and
- (3) the applicant's financial resources; and
- (4) the effect the grant will have on improving the building and/or the district.

(c) Application forms and fact sheets for the Historic Preservation Grant Program may be obtained by contacting the Commission's Director of the Historic Preservation Grant Program.

(i) The installation of new signage or alteration of existing signage, lighting, awnings, marquees or other advertisements, provided that anchorages do not physically affect architectural features underlined in the Description Section of the Designation Report and that the signage, lighting, or awning of marquee is not architecturally significant in itself.

(ii) Any alteration or additions to any portion of the theater exterior not visible from the public way, provided that the protected features of the exterior of any designated interior are not affected.

(iii) Removal of any feature which has not been identified and underlined in the Description Section of the Designation Report of the theater.

(iv) For theaters in which the exterior is designated only for cultural or historical significance, any alterations to the exterior of the theater may be made provided that:

(A) Lighted signage and advertisements for productions are utilized.

(B) Continuous entrance doors are maintained between the lobby and the street and the auditorium exit and the street, where they presently exist.

(C) A marquee is utilized to shelter the sidewalk adjacent to the entrance doors referred to in 4-02(b)(2)(iv)(B).

(D) The existing proportions of the facade (width to height) are not altered.

CHAPTER 6: PROPOSED ALTERATIONS AND NEW CONSTRUCTION OF STRUCTURES AND LANDSCAPES IN THE RIVERDALE HISTORIC DISTRICT.

6-01 INTRODUCTION

6-02 DEFINITIONS

6-03 STATEMENT OF REGULATORY POLICY

6-04 MODIFICATIONS OF AND ADDITIONS TO EXISTING BUILDINGS

6-05 REGULATION OF LANDSCAPE IMPROVEMENTS

6-06 CONSTRUCTION OF NEW STRUCTURES

6-01 INTRODUCTION. The purpose of these rules is to establish the Landmarks Preservation Commission's regulatory policy in the Riverdale Historic District.

The Riverdale Historic District which was developed as an early railroad suburb is characterized as a distinct area of the city by its dramatic and verdant topography and its fine examples of nineteenth and early twentieth century dwellings and carriage houses. The houses and other buildings in the district are harmoniously sited within the landscape and are separated from each other by Landscape Improvements.

Landscaping in the Riverdale Historic District provides the picturesque setting which is a defining element of a romantic style suburb of the nineteenth century. Landscape Improvements such as trees, stone walls and hedges, used to define property lines, and additional plantings within the expansive gardens and alongside the houses, add to the special character of the Historic District.

The district contains 34 buildings of varied type and age. The development of the Riverdale Historic District is important in understanding the district's historical character. Originally, the area was comprised of only seven estates which were served by a common carriage alley (Sycamore Avenue). All of the estates were developed in the 1850's. Several early estate houses remain, as well as stables and carriage houses (later converted for residential use). The configuration of these estates remained intact until 1935, when the original parcels began to be subdivided for development. Four new houses were built between 1935 and 1938. No new buildings were built thereafter until 1950. From 1950 to 1980 twelve new structures were constructed. These newer structures are stylistically diverse but are generally compatible with the older buildings in terms of their placement, height, materials and finish.

6-02 DEFINITIONS. As used in these Rules the following terms shall have the following meanings:

Addition. "Addition" shall mean an extension or increase in the floor area or height of a building that increases its external dimensions.

Commission. "Commission" shall mean the New York City Landmarks Preservation Commission as established by Section 3020 of the New York City Charter.

Demolition. "Demolition" shall mean the dismantling or razing of all or part of an existing Improvement or significant Landscape Improvement.

Improvement. "Improvement" shall mean any building, structure, place, work of art or other object constituting a physical betterment of real property, or any part of such betterment other than a Landscape Improvement.

Landscape improvement. "Landscape improvement" shall mean a physical betterment of real property or any part thereof, consisting of natural or artificial landscaping, including but not limited to grade, terrace, body of water, stream, rock, hedge, plant, shrub, mature tree, path, walkway, road, plaza, wall, fence, step, fountain, or sculpture.

Landmarks Law. "Landmarks Law" shall refer to New York City Charter Section 3020 and Chapter 3 of Title 25 of the Administrative Code of the City of New York.

Landmarks Preservation Commission. "Landmarks Preservation Commission" shall mean the Commission acting in its agency capacity to implement the Landmarks Law.

Mature tree. "Mature tree" shall mean any tree with a trunk diameter of 12" or greater.

Modification. "Modification" shall mean any work to an existing improvement or landscape improvement other than (a) ordinary maintenance or repair; or (b) any Addition.

Permit. "Permit" shall mean any permit other than a Notice to Proceed issued by the Landmarks Preservation Commission in accordance with the provisions of the Landmarks Law.

(a) "PMW" shall mean a Permit for Minor Work as defined by Section 25-310 of the Landmarks Law.

(b) "CNE" shall mean a Certificate of No Effect as defined by Section 25-306 of the Landmarks Law.

(c) "CofA" shall mean Certificate of Appropriateness as defined by Section 25-307 of the Landmarks Law.

Pre-1940 building. "Pre-1940 building" shall mean any building in the Riverdale Historic District built, in whole or in part, prior to January 1, 1940 including buildings which have undergone subsequent remodelling and alterations.

Post-1939 building. "Post-1939 building" shall mean any building in the Riverdale Historic District built on or after January 1, 1940.

Public thoroughfare. "Public thoroughfare" shall mean any publically accessible right of way including, but not limited to a street, sidewalk, public park, and path.

Significant architectural feature. "Significant architectural feature" shall mean any character-defining external component of a building including, but not limited to, the kind, color and texture of the building material and the type and style of any window, door, light, sign, and other fixture appurtenant to any Improvement.

Significant landscape improvement. "Significant landscape improvement" shall mean any landscape improvement which is a character-defining element in its historic district, contributing to the special aesthetic and historic character for which the district was designated, and including but not limited to those landscape improvements identified as landscape features in the designation report.

Special Natural Area District. "Special Natural Area District" shall refer to a Special Purpose District designated by the New York City Planning Commission pursuant to Article X, Chapter 5 of the New York City Zoning Resolution which is mapped in areas where outstanding natural features or areas of natural beauty are to be protected.

6-03 STATEMENT OF REGULATORY POLICY. (a) In regulating modifications and additions to any existing Improvement and construction of any new structures or any work affecting landscape improvements in the Riverdale Historic District, the Landmarks Preservation Commission seeks to preserve the Riverdale Historic District's important landscape qualities and special architectural and historic character.

(b) In the Riverdale Historic District, the Landmarks Preservation Commission finds that the houses and other structures which make an important and significant architectural contribution to the Riverdale Historic District are those built, in whole or in part, before 1940.

(c) In assessing whether proposed work is compatible with the special characteristics of the Riverdale Historic District in terms of the placement, style, size, material and finish of such work, the Landmarks Preservation Commission shall consider such work's proximity to any significant landscape improvement or pre-1940 building and how it may physically or visually impact the building or landscape improvement. The Landmarks Preservation Commission shall also consider the extent of the proposal's visibility from a public thoroughfare.

6-04 MODIFICATIONS OF AND ADDITIONS TO EXISTING BUILDINGS.

(a) Applications for proposed work. An application shall be filed for any proposed modification or addition to any existing improvement or the construction of any new structure within the Riverdale Historic District for review by the Landmarks Preservation Commission and no work shall commence until the Landmarks Preservation Commission has issued a permit approving such work.

(b) Pre-1940 buildings. (1) The Landmarks Preservation Commission shall issue a CNE or a PMW for the following:

(i) Any addition to an existing structure which does not result in damage to or cause the demolition of a significant landscape improvement and which is to be situated in such a way as not to be visible from a public thoroughfare.

(ii) Any modification to an existing structure which:

(A) does not result in damage to or cause the demolition of a significant architectural feature or significant landscape improvement; and

(B) which is compatible with the existing structure's special architectural characteristics in terms of the placement, style, size, materials and finish of such modification.

(2) The Landmarks Preservation Commission shall consider an application for any of the following types of work as a request for a Certificate of Appropriateness (CofA) and shall hold a public hearing on such application:

(i) Any addition which is visible from a public thoroughfare.

(ii) Any modification or addition which does not meet the criteria for issuance of a PMW or CNE set forth in Subsection 6-04(b)(1) above, including any modification or addition which would result in damage to or cause the demolition of a significant architectural feature or significant landscape improvement.

(c) Post-1939 building. (1) The Landmarks Preservation Commission shall issue a CNE or a PMW for the following:

(i) Any addition to an existing structure which does not result in damage to or cause the demolition of a significant landscape improvement and which is to be situated in such a way as to not be visible from a public thoroughfare.

(ii) Any addition to an existing structure which:

(A) although visible from a public thoroughfare does not result in damage to or demolition of a significant landscape improvement; and

(B) is compatible with the special characteristics of the Riverside Historic District in terms of placement, height, roof line, materials and finish of such addition.

(iii) Any modification to an existing structure which:

(A) does not result in damage to or cause the demolition of a significant landscape improvement; and

(B) is compatible with the special characteristics of the Riverside Historic District in terms of its materials and finish.

(2) The Landmarks Preservation Commission shall consider an application for any of the following types of work as a request for a Certificate of Appropriateness and shall hold a public hearing on such application:

(i) Any addition or modification which results in damage to or causes the demolition of a significant landscape improvement.

(ii) Any addition or modification which does not meet the criteria for the issuance of a PMW or CNE set forth above in subsection 6-04(c)(1).

6-05 REGULATION OF LANDSCAPE IMPROVEMENTS.

(a) Actions not Subject to Regulation. (1) The Landmarks Preservation Commission shall not regulate ordinary and beneficial landscaping activities which are in accordance with accepted horticultural practice such as pruning, planting of seasonal flower beds or vegetable gardens, or planting of ornamental shrubs or trees.

(2) The Landmarks Preservation Commission shall not regulate the placement of portable garden furniture nor the installation of any temporary enclosures such as a tent for a party or reception.

(b) Modification of Landscape Improvements. (1) The boundaries of the Riverdale Historic District lie entirely within the Riverdale Special Natural Area District. These rules are intended to work with and complement the Riverdale Special Natural Area District zoning.

(2) The Landmarks Preservation Commission shall regulate any modification to the landscape of the Riverdale Historic District which involves the installation of any permanent fixture or the construction of any structure or paved area or which would cause the demolition of, or have an impact on, any significant landscape improvement. Such work shall include:

(i) modification to or construction of any wall, step, path, drive, railing, fence, gate and gate post, permanent garden structure and pavilion, sidewalk and street gutter;

(ii) any change which affects or impacts upon a hedge or Mature Tree as well as any excavation or fill in a slope exceeding 15 percent; and

(iii) the installation of a new paved area, patio or deck.

(3) The Landmarks Preservation Commission shall issue a CNE or a PMW for the following landscape modifications:

(i) Work which does not result in damage to or demolition of any significant landscape improvement.

(ii) Work which in terms of placement, style, size, material and finish is compatible with the special characteristics of the Riverdale Historic District.

(4) The Landmarks Preservation Commission shall consider any application for a proposed landscape modification which does not meet the criteria for a CNE or PMW set forth above in subsection 6-05 (b)(3) as a request for a Certificate of Appropriateness (CofA) and shall hold a public hearing on such application.

(c) Applications for Proposed Work. An application shall be filed for any proposed work having an effect on any landscape improvement within the Riverdale Historic District for review by the Landmarks Preservation Commission and no work shall commence until the Landmarks Preservation Commission has issued a permit approving such work.

6-06 CONSTRUCTION OF NEW STRUCTURES. Any application for a new structure shall be considered as a request for a Certificate of Appropriateness and shall be reviewed at a public hearing. In determining the appropriateness of any new structure the Landmarks Preservation Commission shall take in to consideration such new structure's location, its proximity to and impact on any pre-1940 building or any significant landscape improvement, its placement into the landscape, and its compatibility with the visual and architectural character of the Riverdale Historic District. Additional considerations shall include the new structure's proximity to a public thoroughfare and the extent of its visibility from a public thoroughfare.

CHAPTER 7: PERMIT EXPIRATION AND RENEWAL

7-01 DEFINITIONS

7-02 DURATION OF PERMITS

7-03 RENEWAL OF PERMITS

7-04 EFFECT OF EXPIRATION OF PERMITS

7-05 MISCELLANEOUS

7-01 DEFINITIONS: As used in these Rules the following terms shall have the following meanings:

Commission. “Commission” shall mean the New York City Landmarks Preservation Commission as established by Section 3020 of the New York City Charter.

Day. “Day” shall mean any day other than a Saturday or Sunday or legal holiday.

Landmarks Law. “Landmarks Law” shall be understood to refer to Section 3020 of the New York City Charter and Chapter 3 of Title 25 of the Administrative Code of the City of New York.

Landmarks Preservation Commission. “Landmarks Preservation Commission” shall mean the Commission acting in its agency capacity to implement the Landmarks Law.

Permit. “Permit” shall mean any permit other than a Notice to Proceed, issued by the Landmarks Preservation Commission in accordance with the provisions of the Landmarks Law:

(a) “PMW” shall mean a Permit for Minor Work as defined by Section 25-310 of the Landmarks Law.

(b) “CNE” shall mean a Certificate of No Effect as defined by Section 25-306 of the Landmarks Law.

(c) “CofA” shall mean Certificate of Appropriateness as defined by Section 25-307 of the Landmarks Law and shall not refer to a Certificate of Appropriateness as defined by Section 25-309.

7-02 DURATION OF PERMITS.

(a) (1) All permits shall be of limited duration as provided by these Rules.

(2) Each permit shall clearly state the expiration date of such permit on the permit.

(b) The following permits shall have the following durations:

(1) Each PMW shall be valid for four (4) years from the date of such PMW.

(2) Each CNE shall be valid for four (4) years from the date of such CNE.

(3) Each CofA shall be valid for six (6) years from the date of a Commission vote on such CofA.

(4) Any PMW, CNE or CofA issued for a Master Plan shall be valid indefinitely.

(c) Without limiting the time periods for permit duration set forth in subsection 7-02(b) where a permit or certificate has been issued to cure a violation, the Commission may require by the terms of such permit or certificate that the work be performed within a specified time period. The failure to perform the work and cure the violation within the specified time period shall mean that the Chair may serve a warning letter, a first, second or subsequent NOV in accordance with the provisions of sections 25-317.1b and 25-317.2 of the Administrative Code.

7-03 RENEWAL OF PERMITS. (a) The Landmarks Preservation Commission may issue a renewal of a permit only upon the satisfaction of all of the following conditions:

(1) An application requesting a renewal shall be filed with the Landmarks Preservation Commission no later than sixty (60) days prior to the expiration date shown on such permit.

(2) The application requesting a renewal shall include (i) a copy of a signed contract which is binding on the parties thereto for the work which is the subject of the permit then expiring and which specifies that work thereunder is to be commenced by a date which is at least sixty (60) days prior to the expiration date of such permit and (ii) if a building permit is required for the work which is the subject of the expiring permit, a copy of a valid building permit based on the Landmarks Preservation Commission's permit for the work which is the subject of the permit then expiring.

(3) No "Notice of Violation" from the Landmarks Preservation Commission shall be in effect against the property subject to the permit for which a renewal is requested; provided, however, that if the Landmarks Preservation Commission shall find that (i) the work which is the subject of the permit for which a renewal is requested (A) will correct a hazardous condition or (B) prevent deterioration affecting the building; or (ii) an escrow agreement, or other acceptable form of assurance, has been established to provide a mechanism acceptable to the Landmarks Preservation Commission to ensure that work approved to correct the Notice of Violation will be completed within a specified time period, then this subsection (3) shall not apply.

(b) If all conditions to the renewal of a permit have been met on or before the expiration date of such permit, the Landmarks Preservation Commission shall issue a renewal permit to the applicant which shall be valid for (i) two(2) years from the date of the expiration of the original permit if the permit renewed is either a PMW or a CNE; or (ii) three(3) years from the date of the expiration of the original permit if the permit renewed is a CofA.

(c) (1) Notwithstanding the foregoing provisions, the Chair of the Landmarks Preservation

Commission shall have the discretion, based on extraordinary circumstances, to allow the renewal of any permit. Such circumstances may include, but shall not be limited to, (i) delays resulting from the inability to obtain other governmental approvals, licenses or permits; or (ii) an inability to complete construction of a project for which work has begun and is continuing with due diligence.

(2) Request for any such discretionary extension shall be made in writing no later than sixty(60) days prior to the expiration date of the permit or within ten(10) days after receipt of notice that the permit will not be renewed, and may include supporting documentation. The Chair shall respond to such request within twenty(20) days of the receipt of the request. If the Chair of the Landmarks Preservation Commission determines that a renewal of the permit should be allowed, the Landmarks Preservation Commission shall renew the permit for a stated term of years.

(3) In allowing the renewal, the Chair may set reasonable conditions including clearing up any outstanding violations within a reasonable stated time.

(d) The expiration of any permit shall be tolled if judicial proceedings to review the decision to grant the permit, or any other governmental approval, license, permit or similar action applied for, or granted in connection with, the project have been instituted until the date of the entry of a final order in such proceedings, including all appeals.

(e) Any person who has been notified by the Commission that a permit will not be renewed because a "Notice of Violation" from the Landmarks Preservation Commission is in effect against the property may request that the Chair of the Commission review whether the Notice of Violation is properly in effect against the property. Such request shall be made in writing within ten (10) days from the date of the notification that the permit will not be renewed and may include supporting documentation. The Chair of the Landmarks Preservation Commission shall respond to such request within twenty (20) days of receipt of the request. If the Chair determines that a Notice of Violation was not properly in effect against the property, the Landmarks Preservation Commission shall issue a renewed permit if it finds that all other conditions set forth in these Rules have been met.

7-04 EFFECT OF EXPIRATION OF PERMITS. (a) Upon expiration of any permit, such permit shall terminate and be of no further effect.

(b) An applicant may apply for a new permit for work which is the subject of an expired permit. The Landmarks Preservation Commission shall treat such application for a renewal which does not meet the condition for the renewal of permits as a new application in all respects subject to all applicable procedures, rules and guidelines in effect at the time of such application for renewal.

7-05 MISCELLANEOUS. Any permit (i) which is either a PMW or CNE issued after the effective date hereof or (ii) which is a CofA which the Commission approves by a vote taken

after the effective date hereof shall be subject to these Rules. (Effective 11/6/92)

CHAPTER 8: PROPOSED ALTERATIONS AND NEW CONSTRUCTION OF STOREFRONTS IN THE JACKSON HEIGHTS HISTORIC DISTRICT

8-01 INTRODUCTION

8-02 DEFINITIONS

8-03 ROUTINE MAINTENANCE

8-04 STOREFRONT ALTERATIONS

8-05 PROCEDURE

APPENDIX A - ILLUSTRATIONS OF DEFINITIONS OF ARCHITECTURAL ELEMENT

APPENDIX B - APPLICATION DRAWINGS

8-01 INTRODUCTION.

These Rules are issued to assist the public in applying to the Landmarks Preservation Commission (the "Commission") for approval for the restoration, rehabilitation, alteration, or replacement of storefronts and associated fixtures in existing buildings within the Jackson Heights Historic District. These Rules enunciate the Commission's policy with respect to such work, and allow the staff of the Commission ("LPC staff") to issue permits for work conforming to these Rules. These Rules will ensure that new storefronts will be consistent with the architectural features that establish the aesthetic, historical, and architectural value and significance of the Jackson Heights Historic District.

The Jackson Heights Historic District represents one of the first areas in the city in which the commercial thoroughfares were designed to complement and integrate with the residential buildings through the use of the same architectural styles and features of adjoining residential buildings. The majority of buildings within the Jackson Heights Historic District were built between 1910 and the 1950's. The styles found in both the residential and commercial buildings of the Jackson Heights Historic District include the neo-Tudor (e.g., English Gables at 37-12 to 37-34 82nd Street), the neo-Romanesque (e.g., Ravenna Court at 80-01 to 80-29 37th Avenue), the neo-Georgian (e.g., Georgian Hall at 83-01 to 83-27 37th Avenue), and the Moderne (e.g., 78-01 to 78-15 37th Avenue).

8-02 DEFINITIONS.

As used in the Jackson Heights Historic District Storefront Rules, the following terms shall have the following meanings:

Awning. "Awning" shall mean a metal frame clad with fabric attached over a storefront, door or window, to provide protection from the sun or rain.

Bulkhead. "Bulkhead" shall mean the part of a storefront that forms a base for one or more display windows (see Appendix A).

Building streetwall. "Building Streetwall" shall mean the predominant plane of the building facade at the level of the storefront.

Canopy. "Canopy" shall mean a metal frame clad with fabric that projects from a building entrance over the sidewalk to the curb, where it is supported on vertical posts.

Commission. "The Commission" shall mean the Commissioners of the Landmarks Preservation Commission, including the Chairman, as established by Section 3020 of the New York City Charter.

Cornice. "Cornice" shall mean a horizontal molded projection that completes the top of a wall, facade, building or storefront (see Appendix A).

Display window. "Display window" shall mean the large glazed portion of the storefront, and the associated framing, above the bulkhead and below the transom, extending from pier to pier. The display window is typically used for the display of goods and to provide daylight and visibility into the commercial space (see Appendix A).

Entrance recess. "Entrance recess" shall mean the recessed opening in the facade leading up to the doorway of a storefront or building entrance (see Appendix A).

Facade. "Facade" shall mean an entire exterior face of a building.

Fixture. "Fixture" shall mean an appliance or device attached to the facade (e.g., awning, sign, lighting fixture, conduit, or security gate).

Historic fabric. "Historic fabric" shall mean a building's original or significant historic facade construction material or ornament, or fragments thereof.

Landmarks Law. "Landmarks Law" shall refer to Section 3020 of the New York City Charter and Chapter 3 of Title 25 of the Administrative Code of the City of New York.

Lighting. "Lighting" shall mean the method or equipment for providing artificial illumination.

Lintel. "Lintel" shall mean the horizontal member or element above a door or window opening (see Appendix A).

LPC staff. "LPC staff" shall mean the staff of the Landmarks Preservation Commission acting in the Commission's agency capacity.

Permit. "Permit" shall mean any permit other than a Notice to Proceed, issued by the Landmarks Preservation Commission, in accordance with the provisions of the Landmarks Law:

- (a) "PMW" shall mean a Permit for Minor Work as defined by Section 25-310 of the

Landmarks Law.

(b) "CNE" shall mean a Certificate of No Effect as defined by Section 25-306 of the Landmarks Law.

(c) "CofA" shall mean Certificate of Appropriateness as defined by Section 25-307 of the Landmarks Law and shall not refer to a Certificate of Appropriateness as defined by Section 25-309.

Pier. "Pier" shall mean a vertical supporting member or element (usually of brick, stone, or metal) placed at intervals along a wall, which typically separate each storefront opening from the adjacent storefront opening (see Appendix A).

Roll-down gate. "Roll-down gate" shall mean a security gate with a mechanism that allows it to roll up and down.

Rules. "Rules" shall mean the rules governing the practice and procedure of the Commission as promulgated in Title 63 of the Rules of the City of New York.

Scissor gate. "Scissor gate" shall mean a security gate with a sideways retractable mechanism.

Security gate. "Security gate" shall mean a movable metal fixture installed in front of a storefront or inside the display window or door to protect the store from theft or vandalism when the store is closed. A security gate can be either the roll-down or scissor variety.

Security gate housing. "Security gate housing" or "housing" shall mean the container that houses the rolling mechanism of a roll-down security gate.

Security gate tracks. "Security gate tracks" shall mean the interior or exterior tracks along the sides of the storefront (for roll-down gates) or along the top and bottom of the storefront (for scissor gates) that hold the edges of the gates.

Sign. "Sign" shall mean a fixture or area containing lettering or logos used to advertise a store, goods, or services (see Appendix A).

Signage. "Signage" shall mean any lettering or logos in general, used to advertise a store, goods, or services.

Sign band. "Sign band" shall mean the flat, horizontal area on the facade usually located immediately above the storefront and below the second story window sill where signs were historically attached. A sign band may also occur within a decorative bandcourse above a storefront (see Appendix A).

Significant architectural feature. "Significant architectural feature" shall mean an exterior

architectural component of a building that contributes to its special historic, cultural, and aesthetic character, or reinforces the special characteristics for which the Jackson Heights Historic District was designated.

Sill. "Sill" shall mean the bottom horizontal member or element of a window or door (see Appendix A).

Skirt. "Skirt" shall mean a bottom finishing piece that hangs from the lower edge of an awning.

Soffit. "Soffit" shall mean the underside of a structural component such as a beam, arch, or recessed area.

Spandrel area. "Spandrel area" shall mean the portion of the facade below the sill of an upper story window and above the lintel of the window or display window directly below it or above the lintel of a window or display window and the building cornice or top of building (see Appendix A).

Storefront bay. "Storefront bay" shall mean the area of the storefront defined by and spanning the two piers.

Storefront infill. "Storefront infill" shall mean the framing, glazing, and cladding contained within a storefront opening in the facade.

Storefront opening. "Storefront opening" shall mean the area of the facade framed by the piers and lintel, which contains storefront infill (see Appendix A).

Transom. "Transom" shall mean a glazed area above a display window or door separated from the display window or door by a transom bar. A transom can be fixed or hinged (see Appendix A).

8-03 ROUTINE MAINTENANCE.

A permit is not required to undertake minor ordinary repairs and cleaning such as:

(a) Window Repair. Ordinary repair and restoration of windows in accordance with the criteria set forth in Section 3-02 (a) of these Rules ("Window Guidelines").

(b) Painting. Scraping, priming, and repainting of storefronts to recoat with the same color and finish, provided that such color and finish either existed at the time of designation or was subsequently applied pursuant to a Commission permit.

(c) Cleaning. Routine cleaning, including polishing of metal storefronts and routine removal of small amounts of graffiti. Routine cleaning does not include sandblasting and chemical cleaning.

(d) Repair or Replacement of Door or Window Hardware. Repair or replacement of door or window hardware, excluding security gate replacement.

8-04 STOREFRONT ALTERATIONS.

LPC staff will issue a CNE or a PMW (if the work does not require a permit from the Department of Buildings) for storefront alterations and replacement provided the work meets all of the following criteria:

(a) Retention of historic storefronts. All existing original or significant historic storefronts shall be retained or repaired if feasible, or if repair is not feasible, replaced in kind.

(b) Permitted storefront alterations. (1) Retention of Significant Protected Features. All alterations to storefront openings, infill, and fixtures shall preserve all significant original and historic architectural components of the existing storefront, including those presently concealed by non-original materials. Such components shall be retained or repaired if feasible, or if repair is not feasible, replaced in kind.

(2) Storefront Openings.

(i) Size and placement. Storefront infill shall fit within the opening established by the original building piers and lintels.

(ii) Separation between storefronts and upper floors. A storefront shall be visually separated from the upper floors or the top of the building by a horizontal architectural component, such as a cornice or sign band.

(3) Storefront Infill. The design of storefront infill shall be based on:

(i) Evidence of the original storefront. An original storefront design shall be determined through references to historic photographs, remnants of historic fabric, or other historic storefronts in the building or similar type of building. (Note: LPC staff can assist you in locating historic photographs.) All such evidence shall be submitted to the Commission with the application; and /or

(ii) General Jackson Heights storefront infill criteria. These criteria, set forth below, reflect the typical historic configuration of storefronts in the Jackson Heights Historic District, which were comprised of three horizontal parts: solid bulkhead, display window, and transom.

(A) Bulkhead. A storefront shall have a bulkhead. The bulkhead shall be between 12 inches and 24 inches in height. The bulkhead shall be built of or clad with one of the following materials:

((a)) brick that matches the existing building facade brick;

- ((b)) stone or cast stone;
- ((c)) paneled wood with molded details; or
- ((d)) metal with molded detail. Corrugated metal shall not be permitted.

(B) Display Window. A storefront shall have one or more display windows. Display windows shall be framed with wood or metal and shall be glazed with clear glass. Any blocking of the transparency of the glass of portions of the storefront shall be reversible and maintain the exterior surface of the glass. Back-painting or the installation of removable opaque panels behind the glass shall be permitted. The installation of tinted or mirrored glass shall not be permitted.

(C) Transom. A storefront shall have a transom above the door(s) if there is sufficient clearance within the existing masonry opening. Transoms are also required above display windows unless it is determined through physical or pictorial evidence that no transom existed originally or if there is not sufficient clearance within the existing masonry opening. Transoms shall be between 12 and 36 inches in height. Transom framing shall match the material and finish of the display window framing. Transoms shall be glazed with clear glass. Back-painted glass or the installation of a solid panel behind the glass shall be permitted when necessary to conceal a dropped ceiling if such ceiling falls below the top of the transom.

(D) Building Streetwall. The overall placement of the bulk-head, display window and display window transom shall conform to the original building streetwall. A new display window, bulkhead, and door that incorporate external roll-down gates, with a recessed housing that complies with the criteria set forth below in 8-04 (b) (6) (ii), may be recessed up to four inches to accommodate the width of the gate tracks.

(E) Entrance. A storefront with out-swinging doors shall have an entrance recessed a minimum of 18 inches from the building streetwall. The sides of the entrance recess shall be splayed or angled outward toward the street, unless restricted by the property line. Recessing is optional if a storefront has in-swinging doors.

(F) Door. A door shall have at least 75% of its surface area glazed with clear glass and shall be framed in wood or metal. Solid, flat (unpaneled) doors are not permitted.

(G) Finish. Non-glazed portions of the storefront infill shall be manufactured in, factory finished with paint or enamel in, or painted on site with one of the following colors or finishes:

- ((a)) Black

- ((b)) Brown
- ((c)) Dark gray
- ((d)) Tan
- ((e)) Dark green
- ((f)) Maroon (dark brownish red)
- ((g)) Silver (stainless steel, clear-finished, or brush-finished aluminum). This finish shall be permitted only for metal storefronts in buildings specified in the Jackson Heights Historic District Designation Report as Art Deco or Moderne Style.
- ((h)) Anodized finishes on aluminum shall be black or silver only. Bronze anodized aluminum shall not be permitted.

(4) Signage.

(i) Types of signs permitted on the ground story.

(A) Back-painted signs on glass doors, display windows or transoms not exceeding 50% of the glazed area. No LPC permit is needed for this type of sign.

(B) Letters and logos pin-mounted or painted on a wood, metal, or opaque glass panel that is mounted flat within the sign band or spandrel. Such signs may be illuminated with a shielded or concealed source of light, or with "goose-neck" type fixtures. Such "goose-neck" fixtures shall be placed above a sign and shall not exceed one fixture for every 3 linear feet of sign.

(C) Neon signs installed in the display window behind the glass, provided that the perimeter of the window is not outlined with neon, the transparency of the display window is not materially reduced, and the size of the sign does not exceed 2 feet by 2 feet per display window.

(D) Individual pin-mounted opaque letters and logos illuminated from behind, each glowing with a halo of light, or individual letters with exposed neon tubes (no lenses). The letters or logos may be mounted on a flat metal or wood panel, or affixed to a base measuring no more than 4 inches deep by 4 inches high that houses the electrical conduit.

(E) Signs painted on awnings (if permitted under the awning rules, set forth below in 8-04 (b) (5)).

(F) Small identification signs for second story tenants are permitted near the entrance to the second story premises.

(ii) Types of signs permitted on the second story.

(A) Back-painted signs on glass windows or transoms not exceeding 50% of the

glazed area. No LPC permit is needed for this type of sign.

(B) Letters and logos pin-mounted or painted on a wood, metal or opaque glass panel, which is mounted flat on an area of plain masonry.

(C) Neon signs, installed in the second floor window behind the glass, provided that the perimeter of the window is not outlined with neon, the transparency of the second floor window is not materially reduced, and the size of the sign does not exceed 18 inches by 18 inches per window.

(D) Signs painted on awnings (if permitted under the awning rules, set forth below in 8-04(b)(5)).

(iii) Types of signs not permitted.

(A) Projecting banners and flagpoles

(B) Internally illuminated box signs with plastic or glass lenses.

(C) Internally illuminated fabric signs or awnings.

(D) Flashing signs, moving signs, or strobe-lights.

(E) Neon border outline around perimeter of a window.

(F) Signs or advertising added to bulkheads.

(iv) General criteria for sign installation. Installation of the sign shall not damage or obscure significant architectural features of the building and/or the storefront.

(v) Criteria for sign installation at ground story.

(A) Ground story signs shall be installed in the sign band, spandrel, display window, transom, or door.

(B) The height of the sign shall not exceed the height of the sign band, or, if there is no sign band, the spandrel area above the storefront.

(C) The length of the sign shall not exceed the length of the frontage of the storefront opening.

(vi) Criteria for sign installation at the second story.

(A) A second story sign shall relate to the commercial premises located at the second story.

(B) A second story sign may be placed on the building facade either in the spandrel area above the second story windows or centered between second story windows. The placement of second story signage shall be consistent for a single building.

(C) A sign located above a second story window shall not exceed 20 inches in height or the lesser of 6 feet in length or the width of the window(s) for the commercial premises.

(D) A sign placed between windows on the second story shall not exceed 30 inches in height or 3 feet in length.

(E) Second story signs on the facade shall not be externally or internally illuminated, except for neon signs that comply with the criteria set forth above in 8-04(b)(4)(ii)(C).

(5) Storefront Awnings. These rules apply to the installation of awnings above ground story storefronts and above upper story windows. For storefronts in the Jackson Heights Historic District, the following criteria apply in lieu of the general awning rule set forth in Section 2-12 of the Rules. If a new storefront is being installed and an awning is desired, the storefront shall incorporate an awning in compliance with the criteria set forth below. Existing awnings in non-compliance with these criteria cannot be maintained unless the applicant can demonstrate to LPC staff that the new storefront installation will not require the removal of the existing awning.

(i) General awning criteria.

(A) An awning may be retractable or fixed. If fixed, the awning shall have a straight slope, be open on the sides, and have an unframed, flexible skirt. The awning skirt shall not exceed 10 inches in height. If retractable, the awning shall have a straight slope.

(B) The awning shall be attached to the facade at the lintel or transom bar, except that the awning may be attached above the lintel and below or within the lower portion of the sign band where:

((a)) an existing or permitted roll-down security gate makes it impossible to install the awning at the lintel or transom bar; or

((b)) installing the awning at the lintel or transom bar will result in the lowest portion of the awning being less than eight feet above the sidewalk.

Where the awning is installed above the lintel but below or in the lower portion of the sign band, the awning encroachment on the area above the lintel shall be the minimum required to accommodate the conditions described above in subparagraphs ((a)) and ((b)).

(C) The length of the awning shall not exceed the length of the storefront opening or the associated window opening and the edges of the awning shall be aligned with the inside face of the principal piers of the storefront, or the window opening.

(D) The underside of the awning shall be open.

(E) The lowest portion of awning shall be at least 8 feet above the sidewalk.

(F) The awning shall project between three feet and six feet from the building street wall.

(G) The awning shall be clad only with water repellant canvas with a matte finish or other fabric of a similar appearance.

(H) A sign may be painted on the awning skirt. Such sign shall not exceed 8 inches in height.

(I) A sign may not be painted on the sloped portion of the awning unless the building has no sign band or spandrel area above the ground floor storefront. Such signs shall be proportionate with the size of the awning, but in no event shall such signs exceed 6 square feet in area per awning.

(ii) Types of awnings not permitted. The following types of awnings are not permitted:

(A) Fixed box awnings.

(B) Fixed waterfall or curved awnings.

(C) Novelty awnings.

(D) Translucent or transparent awnings illuminated from within or beneath.

(iii) Canopies. Canopies are not permitted.

(6) Security Gates.

(i) General requirements. A security gate shall not obscure or detract from the design and details of an existing storefront and shall be architecturally integrated with the design and construction of a new storefront.

(ii) Security gates for new storefronts. If security gates are required, the new storefront shall be constructed with an internally-housed or completely internal security gate system or scissor gates. Subsequent to a new storefront installation, LPC staff will not approve a security gate in noncompliance with the criteria set forth below.

(A) Roll-down gates. All roll-down security gates installed pursuant to these rules shall be composed entirely of open mesh or have a solid metal panel at the base that does not exceed the height of the bulk-head it covers.

(B) Internal gates. A roll-down security gate may be mounted on the interior of the storefront. An internally mounted gate is required if an externally mounted gate cannot be installed in compliance with the criteria for external gates set forth below in subsection (C).

(C) External gates. A roll-down security gate may be mounted on the exterior of the storefront if it (1) does not affect, obscure, or damage historic fabric, (2) the security gate housing is located on the interior of the storefront, or the outer face of the security gate housing is set so as not to protrude beyond the building streetwall, and (3) the security gate tracks are recessed or set into reveals along the sides of the storefront.

(D) Scissor gates. Scissor gates are permitted if their installation does not obscure or damage any significant architectural feature.

(iii) Security gates for existing storefronts.

(A) An internal gate, scissor gate, or external gate may be installed if the installation is in compliance with the relevant criteria set forth above in 8-04(b)(6)(ii)(A-D).

(B) A replacement external gate that is not in compliance with the criteria set forth above in 8-04(b)(6)(ii)(C) may be mounted on the exterior of the storefront if the following criteria are met:

((a)) the existing storefront is not being replaced and the storefront had an exterior roll-down gate at the time of the designation of the Jackson Heights Historic District;

((b)) the installation of the new security gate shall not obscure or damage any significant architectural features; and

((c)) the security gate housing and tracks shall be finished in a color to match or harmonize with the storefront and the security gate housing will be completely covered by an awning that is installed and maintained in compliance with the awning rules set forth above in subsection 8-04(b)(5); and

((d)) the security gate shall be composed entirely of open mesh or shall have a solid metal panel at the base that does not exceed the height of the bulkhead it covers.

(7) Lighting.

- (i) The installation of lighting conduits and fixtures shall not obscure or damage any significant architectural feature.
- (ii) Lighting conduits shall be internal or not visible.
- (iii) External light fixtures shall illuminate only the storefront and/or ground story signs.
- (iv) The number and size of light fixtures shall be in keeping with the scale of the storefront.
- (v) The design of light fixtures shall be utilitarian or shall complement the architectural style and detail of the building.
- (vi) Fluorescent and high intensity light shall be permitted only if the source of light is concealed and shielded.
- (vii) Recessed light fixtures shall be mounted within the soffits of recessed storefront entrances.
- (viii) No separate light fixture shall illuminate any sign with internal illumination.

(8) Air conditioners/louvers. Temporary, seasonal air conditioning units shall be installed in transoms over doors. Louvers for built-in air conditioning, heating or ventilation units may be installed at the door or window transoms. Louvers shall be mounted flush with the plane of the transom, and painted to match the color of the surrounding storefront elements.

8-05 PROCEDURE.

(a) Submission of application. The rules for making an application are set forth in Chapter 2, Subchapter A ("Application Procedure") of these Rules. The illustrations included in Appendix B provide hypothetical examples of the types of storefronts and storefront installations which are permitted under these rules.

(b) Review of application

(1) When the application is complete, a staff member will review the application for conformance with the criteria set forth in this Chapter 8. Upon determination that the criteria of the guidelines have been met, a permit will be issued within 20 business days for a PMW or 30 business days for a CNE, as measured from the day the staff determines that the application is complete.

(2) If the criteria have not been met, the applicant will be given a notice of the proposed denial of the application and an opportunity to meet with the Director of the Preservation Department, or, when the Director is not available, with a Deputy Director, to discuss the interpretation of these rules. The applicant must request such a meeting in writing within 10 business days from the date of the notice of proposed denial.

(3) If an application for work is denied a PMW or CNE under these Rules, the applicant shall be informed of his or her right to file for a CofA pursuant to Title 25, Chapter 3 of the Administrative Code of New York City.

(c) Illustrations. Drawings are the most effective way to illustrate the proposed work in a clear and precise fashion. The drawings contained in Appendix B of this Chapter 8 are examples of the types of drawings an applicant will be required to submit to the LPC as components of a complete application. As examples, these drawings have been simplified to generalize and illustrate many of the definitions and the requirements enunciated in the rules above. Submissions to the Commission must be specifically tailored to individual proposals. Drawings must be made to scale, and include all pertinent dimensions. Applications also may be supplemented, as necessary, with photographs of existing conditions, construction details, materials samples, specifications, and maps, to best explain the proposed work.

APPENDIX A: ILLUSTRATIONS OF DEFINITIONS OF ARCHITECTURAL ELEMENT

JACKSON HEIGHTS STOREFRONT RULES

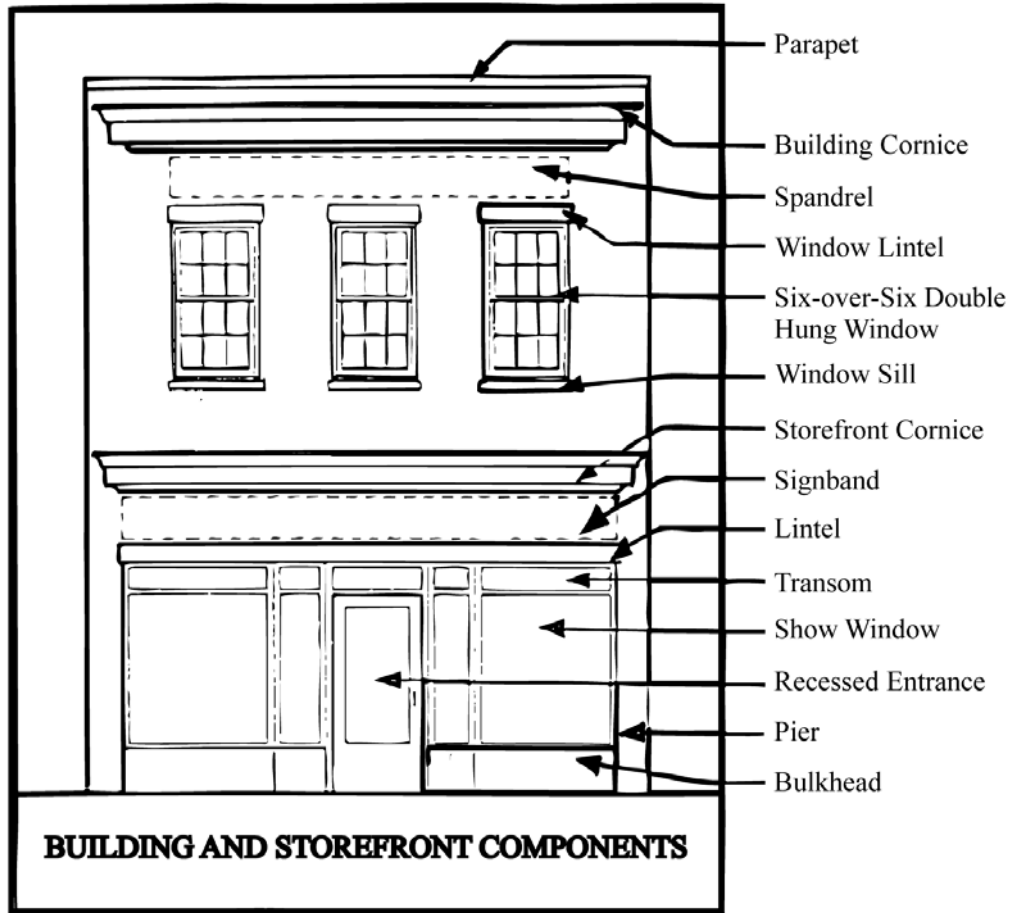

APPENDIX B: APPLICATION DRAWINGS

JACKSON HEIGHTS STOREFRONT RULES

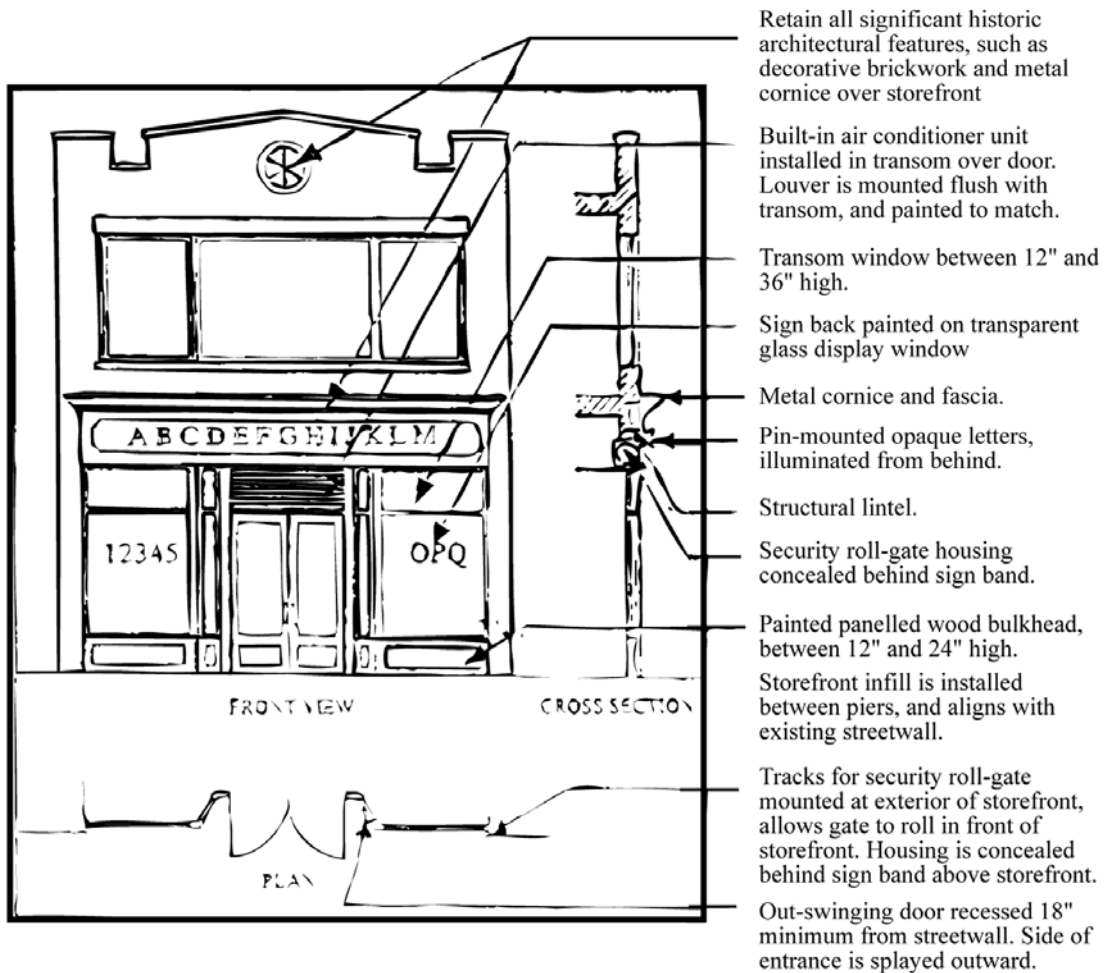

EXAMPLE TWO - STOREFRONT WITH CENTER ENTRANCE

JACKSON HEIGHTS STOREFRONT RULES

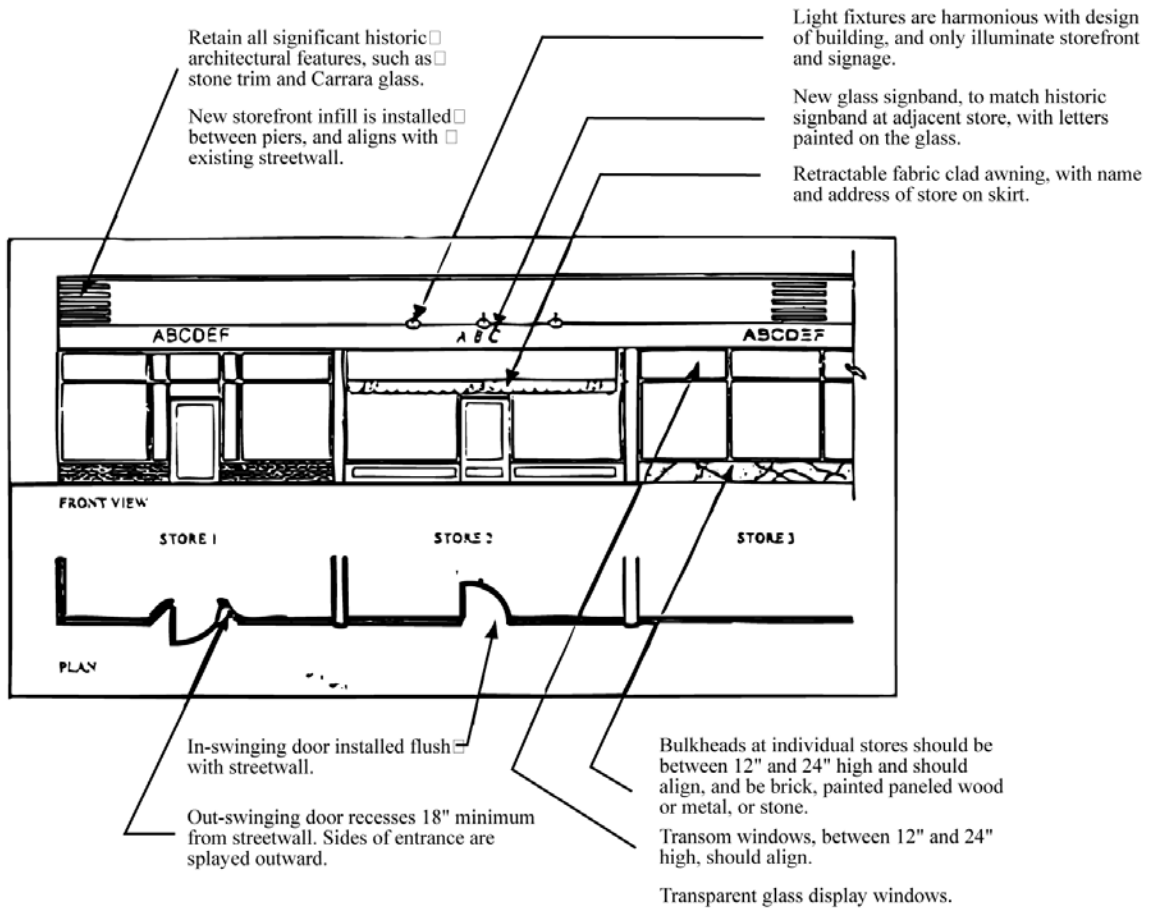

EXAMPLE THREE - BUILDING WITH MULTIPLE STOREFRONTS

CHAPTER 9: ALTERATIONS TO DESIGNATED BANK INTERIORS

9-01 INTRODUCTION

9-02 DEFINITIONS

9-03 ELIGIBLE INTERIORS

9-04 CHANGES TO NON-SIGNIFICANT FEATURES

9-05 STATE-OF-THE-ART BANKING CHANGES

9-06 APPLICATIONS FOR COMPLETE OR PARTIAL REMOVAL OF TELLER COUNTERS

9-07 APPLICATION PROCEDURES

9-01 INTRODUCTION. (a) These rules are issued to assist building owners in applying to the Landmarks Preservation Commission (LPC) for approval of applications to undertake repair, rehabilitation, replacement of, or alterations to interior architectural features within designated bank interiors. The rules set forth Commission policy with respect to such repair, rehabilitation, replacement, or alteration and explain the procedures required to apply for a permit. The goal of these rules is to facilitate and encourage the continued historic use of these interiors as banking floors and to facilitate the adaptive reuse of the interior if it ceases to be used as a banking floor.

(b) These rules are based on the following principles:

(1) The significant original visual qualities or character of a designated interior should not be destroyed. The removal or alteration of any significant architectural feature should be avoided whenever possible.

(2) Significant but deteriorated architectural features should be repaired rather than replaced whenever possible.

(3) Certain interior alterations can be approved at staff level in conformance with the procedures set forth in these rules. Other interior alterations require review by the full Commission in accordance with its usual review procedures.

(c) These rules are keyed to underlined portions of the Description section of the Designation Reports for these interior landmarks, which identify significant architectural features requiring protection.

(d) Applicants are encouraged to submit applications for Master Plans which will govern the approval of routine and continuing alterations such as installation of mechanical and electrical equipment.

9-02 DEFINITIONS. As used in these Rules, the following terms shall have the following meanings:

Banking interior. "Banking interior" shall mean the area of the designated interior historically used for banking operations and any associated interior spaces including, without limitation, entrance vestibules or mezzanines identified in the designation report as part of the designated interior.

Commission. The "Commission" shall mean the eleven Commissioners, including, the Chairman, as established by Section 3020 of the New York City Charter.

Interior architectural features. "Interior architectural features" shall have the meaning established in Section 25-302 of the Administrative Code of the City of New York.

Landmarks Law. "Landmarks Law" shall refer to Section 3020 of the New York City Charter and Chapter 3 of Title 25 of the Administrative Code of the City of New York.

LPC. "LPC" shall mean the Landmarks Preservation Commission acting in its agency capacity to implement the Landmarks Law.

Non-significant features. "Non-significant features" shall mean the interior architectural features of the designated interior that the LPC has determined do not contribute to the special historic, cultural, and/or aesthetic character for which the interior was designated. These features comprise all of the interior architectural features of the interior with the exception of those features that are underscored in the designation report.

Significant features. "Significant features" shall mean the interior architectural features of the designated interior that the LPC has determined contribute to the special historic, cultural, and/or aesthetic character for which the interior was designated and therefore require protection under these rules. These features are identified in the designation reports and indicated by underscoring.

Reversible alteration. "Reversible alteration" shall mean an alteration in which the altered feature can be readily returned to its appearance prior to the alteration.

State-of-the-art banking change. "State-of-the-art banking change" shall mean a physical alteration to the bank interior that the applicant has determined to be necessary to accommodate changes in technology and/or banking practice. When submitting an application to make such an alteration, the applicant must enclose a verified statement executed by the manager of the bank stating that the bank's ability to perform its banking functions would be impaired if it were unable to make such an alteration.

Terms not otherwise defined in these rules shall have the meanings given them in the Landmarks Law.

9-03 ELIGIBLE INTERIORS & SIGNIFICANT FEATURES. (a) The following interior landmarks are subject to these rules:

1. Former Emigrant Industrial Savings Bank, 51 Chambers Street, Manhattan
2. Former New York Bank for Savings, 81 Eighth Avenue, Manhattan
3. Former Greenwich Savings Bank, 1352-1362 Broadway, Manhattan
4. Former Central Savings Bank, 2100-2114 Broadway, Manhattan
5. Former Dollar Savings Bank, 2516-2530 Grand Concourse, Bronx
6. Dime Savings Bank, 9 DeKalb Avenue, Brooklyn
7. Former Bowery Savings Bank, 130 Bowery, Manhattan
8. Former Bowery Savings Bank, 110 East 42nd Street, Manhattan
9. Williamsburgh Savings Bank, 1 Hanson Place, Brooklyn
10. Williamsburgh Savings Bank, 175 Broadway, Brooklyn
11. Brooklyn Trust Company, 177 Montague Street, Brooklyn

In addition, any interior landmark or portion thereof which the Commission designates subsequent to the enactment of these rules and which is described as a banking interior in the designation report shall be subject to these rules.

9-04 CHANGES TO NON-SIGNIFICANT FEATURES. (a) The LPC staff will issue a Certificate of No Effect on Protected Architectural Features (CNE) or a Permit for Minor Work (PMW) (if the work does not require a permit from the Department of Buildings) within five working days of receipt of a completed application for any proposed work to a non-significant feature if the following conditions are met.

- (1) The visible volume and configuration of the banking interior is maintained; and
- (2) The staff determines that the alteration will not adversely affect any significant architectural feature and will not detract from the overall visual character of the banking interior.

9-05 STATE-OF-THE-ART BANKING CHANGES. (a) The LPC staff will issue a CNE or PMW within fifteen working days of receipt of a completed application for a state-of-the-art banking change, if all of the following conditions are met:

- (1) the visible volume and configuration of the banking interior is maintained; and
- (2) the proposed alteration is the least intrusive means available to achieve a state-of-the-art banking change, such as the installation of ATMs or security devices; and
- (3) that (i) the proposed alteration will have no effect on the physical fabric of the significant features or (ii) such effect is reversible, and that the applicant will ensure that the physical fabric of the significant feature will be replaced or restored after the proposed alteration is no longer required to achieve a state-of-the-art banking change.

- (b) Any proposed alteration that includes the partial or complete removal or relocation of the teller counter or the removal of a significant portion of its fittings or fixtures requires a Certificate of Appropriateness (CofA) from the Commission in accordance with the procedures and criteria set forth in the Landmarks Law if the teller counter and/or such fittings or fixtures is a significant feature.

9-06 APPLICATIONS FOR PARTIAL OR COMPLETE REMOVAL OF TELLER COUNTERS. (a) Any CofA application that includes the partial or complete removal of the teller counter or the complete or partial removal of the teller counter and its associated fixtures may include a written statement setting forth the reasons why such removal is appropriate.

(b) In its consideration of the appropriateness of the proposed removal the Commission may consider, among other things, whether the partial or complete removal of the teller counter or its fittings or fixtures would damage any other significant architectural feature and the extent to which the proposed alterations would restore the affected portions of the banking floor and/or exposed counter-end to an appropriate condition. In addition, the Commission, in its discretion, may, if the applicant is not a public or quasi-public agency, require the applicant to establish an escrow account or other adequate assurance to provide for the disassembly, removal, secure storage, and replacement of the teller counter and/or its fittings and fixtures for such time and under such conditions as the Commission shall determine and describe in the CofA.

9-07 APPLICATION PROCEDURES. (a) Submission of application. See Chapter 2, Subchapter A ("Application Procedure") of these rules.

(b) Review procedure. (1) When the application is complete, staff will review the application for conformance with these rules. Upon determination that the criteria of the rules have been met, a PMW or CNE will be issued.

(2) If the criteria set forth in these rules for a CNE or PMW have not been met, the applicant will be given a notice of the proposed denial of the application pursuant to these rules and an opportunity to meet with the Director of the Preservation Department, or, in the absence of the Director, with a Deputy Director, to discuss the interpretation of these rules. After this meeting has taken place, if the applicant would like to discuss the matter further, he or she will be given an opportunity to meet with the Chairman for additional discussion of the application.

(3) Applications for work which does not qualify for the issuance of a CNE or PMW in accordance with these rules shall be subject to the LPC's usual review procedure as set forth in the Landmarks Law.

CHAPTER 10: NOTIFICATION TO LESSEES OF LANDMARKS DESIGNATION & PERMIT REQUIREMENTS.

10-01 INTRODUCTION

10-02 NOTICE TO TENANT OF LANDMARKS DESIGNATION

10-03 NOTIFICATION

10-01 INTRODUCTION. These rules are issued to assist the owners and other persons in charge of improvements or property that is a landmark, interior landmark or located on a landmark site or in a historic district in complying with the nonresidential tenant notification requirements set forth in Section 25-322 of the Administrative Code of the City of New York.

10-02 NOTICE TO TENANT OF LANDMARKS DESIGNATION. The language set forth below shall satisfy the notification requirements set forth in Section 25-322 of the Landmarks Law.

"The tenant [lessee] is hereby notified that the leased premises are subject to the jurisdiction of the Landmarks Preservation Commission. In accordance with sections 25-305, 25-306, 25-309 and 25-310 of the Administrative Code of the City of New York and the rules set forth in Title 63 of the Rules of the City of New York, any demolition, construction, reconstruction, alteration or minor work as described in such sections and such rules may not be commenced within or at the leased premises without the prior written approval of the Landmarks Preservation Commission. Tenant is notified that such demolition, construction, reconstruction, alterations or minor work includes, but is not limited to, (a) work to the exterior of the leased premises involving windows, signs, awnings, flagpoles, banners and storefront alterations and (b) interior work to the leased premises that (i) requires a permit from the Department of Buildings or (ii) changes, destroys or affects an interior architectural feature of an interior landmark or an exterior architectural feature of an improvement that is a landmark or located on a landmark site or in a historic district. "

10-03 NOTIFICATION.

(a) Lease Notification. Any nonresidential lease or sublease (including any renewal thereof) executed after December 13, 1996 for property or an improvement that is a landmark, interior landmark or located on a landmark site or in a historic district shall include the notice set forth in Section 10-02 above. Such notification shall be highlighted in bold or underscored or otherwise highlighted so that it is conspicuously set forth.

(b) Letter Notification. If an improvement or property is designated as a landmark or an interior landmark or included as part of a landmark site or historic district during the term of a nonresidential lease or a sublease of all or a portion of such improvement or property, the lessor of such lease or sublease shall within 30 days after being notified of such designation by the Landmarks Preservation Commission or person in charge, send the written notice set forth in Section 10-02 to the nonresidential lessee or sublessee. Such notice shall be highlighted in bold

or underscored or otherwise highlighted so that it is conspicuously set forth. Such notice shall be sent by certified or registered mail, return receipt requested to all nonresidential lessees on the first two floors (excluding the basement or cellar) and shall be sent to all other nonresidential lessees by any means reasonably designed to ensure that notice is given.

CHAPTER 11: ADMINISTRATIVE ENFORCEMENT

INTRODUCTION

11-01 DEFINITIONS.

11-02 ENFORCEMENT OF NOTICES OF VIOLATION.

11-03 SERVICE OF NOTICE OF VIOLATION.

11-04 WARNING LETTER.

11-05 NOTICE OF VIOLATION; GRACE PERIOD.

11-06 STOP WORK ORDER.

INTRODUCTION. These rules are promulgated to implement the provisions of Sections 25-317.1 and 25-317.2 of the Administrative Code, insofar as such sections concern the issuance of notices of violation, warning letters and stop work orders and the enforcement of the requirements of Chapter 3, Title 25 of the Administrative Code in administrative tribunals, including the imposition and adjudication of administrative penalties.

11-01 DEFINITIONS. The following definitions shall apply to this chapter:

(a) The term "Landmarks Law" shall mean Chapter 3 of Title 25 of the Administrative Code of the City of New York.

(b) The term "respondent" shall mean a person who is alleged to have violated the Landmarks Law by creating, authorizing, performing or maintaining work on a landmark site, within the boundaries of a historic district or to any part of an interior landmark without, or in violation of, a permit from the Landmarks Preservation Commission ("Commission").

(c) The term "stop work order" shall mean an order, issued pursuant to section 25-317.2 of the Administrative Code.

(d) A violation is "corrected" by removing the illegal condition, only where such condition can be easily removed without damage to underlying building material and where such removal does not require a permit from the Commission. For example, a violation for the installation of a sign or awning without a permit may be corrected by removing the sign or awning, if such removal does not result in damage to the underlying building material. Correcting a violation does not include or otherwise permit the reinstallation of a preexisting condition or the installation of a substitute condition. For example, a violation for the installation of a sign or awning without a permit, where such installation involved the removal of a preexisting sign or awning, may not be corrected by reinstalling the prior sign or awning, or installing a different sign or awning. A violation is not corrected for purposes of section 25-317.1(b)(6) of the Landmarks Law if the same or similar illegal condition is installed within 180 days of the respondent's representation to the Commission that the violation has been corrected.

(e) A violation is "legalized" when the Commission issues a permit approving and

authorizing the work that was done without a permit.

(f) A violation is "cured" where the Commission issues a permit authorizing modifications to the illegal condition to make it appropriate, or where the Commission authorizes work to replace the illegal work, and the modification or replacement work is completed, and the Commission has issued a Notice of Compliance.

(g) For purposes of sections 11-03, 11-04 and 11-06, the term "mail," "mailed" and "mailing" shall mean first class United States mail or express or overnight delivery to a respondent as follows:

(1) Where the respondent is an owner, the warning letter, notice of violation or stop work order shall be mailed to the owner's address as contained in the records of the Department of Finance for purposes of the assessment or collection of real estate taxes or as contained in the records of the Commission for purposes of the implementation or enforcement of the relevant portions of the Charter or Administrative Code.

(2) Where the respondent is a tenant or occupant of the premises where the violation occurred, the warning letter, notice of violation or stop work order shall be mailed to the address where the violation occurred.

(3) Where the respondent is a contractor or other person who performed or was in charge of overseeing the work that was done without, or in violation of, a permit, the warning letter, notice of violation or stop work order shall be mailed to the contractor's or person's business address as generally advertised or represented to the public, unless such contractor or other person is the owner, tenant or occupant.

(4) Where the respondent is any other person in charge of a designated improvement or improvement parcel, the warning letter, notice of violation or stop work order shall be mailed to such person's business address, as generally advertised or represented to the public, or as such address is contained in the records of the Department of Finance for purposes of assessment or collection of real estate taxes or as contained in the records of the Commission for purposes of the implementation or enforcement of the relevant portions of the Charter or Administrative Code.

11-02 ENFORCEMENT OF NOTICES OF VIOLATION. All first Notices of Violation ("NOV") issued after July 5, 1998 for a Type A or Type B Violation shall be heard at the Environmental Control Board ("ECB") or its successor. For Type A Violations, all second and subsequent NOV's for the same condition shall be heard at the Office of Administrative Trials and Hearings ("OATH") or its successor. For purposes of this subchapter, OATH shall be authorized to issue final, binding decisions. For Type B Violations, second and subsequent NOV's shall be heard at the ECB. Notices of violation for violating a stop work order may be heard at either ECB or OATH.

11-03 SERVICE OF NOTICE OF VIOLATION. In addition to the service requirements of the court or tribunal at which an NOV is to be heard, a NOV may be served by mailing such Notice of Violation to a respondent.

11-04 WARNING LETTER. Subject to the exceptions set forth in section 25-317.1(b)(1) of the Administrative Code, the LPC shall mail a warning letter to a respondent prior to the issuance of a NOV. The warning letter shall inform the respondent that the LPC believes a violation of the Landmarks Law has occurred at the subject premises and shall also: (1) describe the violation in general detail; (2) warn the respondent that the law authorizes civil and criminal penalties for violations; (3) notify the respondent that a NOV may be served unless, within 20 working days of the date of the warning letter, the violation is corrected or an application to legalize or cure the violation is received by the Commission.

11-05 NOTICE OF VIOLATION; GRACE PERIOD. [As amended July 2, 1999.] (a) A respondent shall qualify for the grace period set forth in section 25-317.1(b)(6) of the Administrative Code by delivering, at least 14 days prior to the hearing date set forth in the NOV, the following to the Commission:

- (1) Admission of liability, and
- (2) proof, satisfactory to the Commission, that the violation has been corrected, or
- (3) an application to legalize or cure the violation.

(b) For purposes of subsection (2), "proof" shall mean the submission of an affidavit or other sworn statement describing the violation and the work performed to correct the violation. The affidavit or sworn statement shall be supplemented by photographs and any other supporting material that demonstrates that the illegal condition has been corrected. The Commission may reject the proof submitted if it does not unequivocally demonstrate that the illegal condition has been corrected.

11-06 STOP WORK ORDER. Service. A stop work order may be served: (1) by mailing the stop work order to the respondent; (2) by affixing the stop work order to the place where the violation is occurring. Where the stop work order is affixed, a copy of the order shall also be mailed to the respondent; (3) or orally. Where the stop work order is given orally, the Commission shall within 48 hours thereof mail a copy of the stop work order to the respondent.

CHAPTER 12: HISTORIC DISTRICT MASTER PLANS.

12-01 DISTRICT MASTER PLAN AND AUTHORIZATION TO PROCEED. 12-02 STONE STREET HISTORIC DISTRICT MASTER PLAN IMPLEMENTATION RULES.

12-01 DISTRICT MASTER PLANS AND AUTHORIZATIONS TO PROCEED.

(a) Introduction. The Commission may develop master plans for the historic district, specific types of buildings within a historic district, distinctive areas within the historic district or for landmark sites containing multiple buildings. A district master plan may address common design issues such as storefront design, signage, sidewalk and areaway alterations as well as set forth specific alterations for individual buildings in an historic district or on a landmark site in a comprehensive manner that respects the significant architectural features and particular history of the historic district with allowances for specific building conditions. A district master plan may serve as a research tool or design guide for owners or tenants who wish to make alterations to their buildings. Upon the adoption of implementation rules as set forth in this rule, Commission staff can also issue authorizations to proceed for certain types of alterations or work set forth in the district master plan. A District Master Plan does not preclude the Commission's consideration and approval of applications for proposed work that is not in compliance with the District Master Plan.

(b) District Master Plans. Upon its own motion, the Commission may consider a master plan for alterations in a specific historic district, an individual landmark site containing multiple buildings or with respect to certain types of buildings or types of work in a specific historic district ("District Master Plan"). A District Master Plan may be approved by a Certificate of Appropriateness, a Certificate of No Effect on Protected Architectural Features, or a Permit for Minor Work, depending on the work covered by the plan.

(c) Calendaring. A District Master Plan will not be scheduled for the Commission's consideration unless the Commission, in its discretion and upon the adoption of a motion, votes to calendar the District Master Plan for a public hearing. A motion to calendar a proposed District Master Plan for further consideration must be approved by the majority of Commissioners present in order to be adopted. The date of the public hearing on the proposed District Master Plan may be set by the motion to calendar or may be set at some later time by the Chairman, acting at his or her discretion.

(d) Public Hearing. If the Commission votes to calendar a District Master Plan for further consideration, a public hearing will be held in accordance with Section 25-308 of the Administrative Code of New York City and the provisions of Chapter One of these Rules.

(e) Approval and Implementation. Following the public hearing, the Commission may vote to approve, approve with modifications, or disapprove the District Master Plan. If the District Master Plan is approved or approved with modifications, the District Master Plan may

be implemented by the enactment of Rules in accordance with the City Administrative Procedure Act that specifically reference the District Master Plan ("Implementation Rules"). The Implementation Rules shall establish the scope and applicability of the District Master Plan and shall set forth the application procedures and the criteria for issuance of Authorizations to Proceed ("ATP's", see subsection 12-01(f) below) pursuant to the District Master Plan. Any work permitted under the Implementation Rules pursuant to an ATP must be described with reasonable specificity as to design and materials in the District Master Plan. The public hearing for the proposed District Master Plan may be held concurrently with the public hearing for the Implementation Rules. However, the Commission must vote to approve the District Master Plan before it votes to approve the Implementation Rules and the District Master Plan shall have no force and effect until the Implementation Rules are adopted in accordance with the City Administrative Procedure Act.

(f) Authorizations to Proceed. All applications for work pursuant to the District Master Plan must be signed by the building owner in accordance with Section 2-01 of these Rules and must state that the application is being filed pursuant to the District Master Plan. Each application shall include drawings, specifications and other materials which describe the proposed work in detail. Commission staff will review the application to ascertain whether the proposed work is in accordance with the District Master Plan and the Implementation Rules. If Commission staff determines that the work is in compliance with the District Master Plan and the Implementation Rules, the staff will send the applicant an "Authorization to Proceed" letter ("ATP") allowing the work to commence. The ATP must be obtained prior to the commencement of work and posted on the building while work is in progress. Each ATP shall be valid for four (4) years from the date of such ATP and may be renewed upon application provided that Commission staff determines that the work authorized under the original ATP remains in compliance with the District Master Plan and the Implementation Rules in effect on the date of such renewal. Issuance or renewal of a District Master Plan ATP is contingent upon the work's adherence to the District Master Plan and the materials and plans submitted and approved by Commission staff in connection with the ATP.

(g) Amendment and Rescission. Upon its own motion, the Commission may amend or rescind a District Master Plan at any time, provided the Commission first holds a public hearing on the proposed amendment or rescission. In its discretion, the Commission shall calendar a public hearing with respect to such proposed amendment or rescission in accordance with the provisions of Section 12-01(b) of these Rules. Any Commission action to amend or rescind a District Master Plan shall be in accordance with the provisions of Section 1-04 of these Rules.

12-02 STONE STREET HISTORIC DISTRICT MASTER PLAN IMPLEMENTATION RULES.

(a) Introduction

The Stone Street Historic District is a low-scale cluster of early nineteenth-century commercial structures, complemented by several picturesque early twentieth-century buildings designed by prominent architects. The Stone Street Historic District is a distinct enclave amidst

the surrounding twentieth-century skyscrapers and is sited on narrow winding streets originally laid out by Dutch Colonists.

The Stone Street Historic District Master Plan Implementation Rules ("Rules") are promulgated to assist building owners who own buildings located within the Stone Street Historic District in applying to the Landmarks Preservation Commission ("LPC") for approval of applications to undertake repair, rehabilitation, replacement, or alterations to storefronts (including but not limited to storefront infill, lighting, signage, security gates) and cellar entrances, and to make such buildings accessible to persons with disabilities, that are in accordance with the Stone Street Master Plan approved by the Commission. The Stone Street Master Plan is a master plan governing work to storefronts and cellar entrances, as well as alterations to make buildings within the historic district accessible to persons with disabilities. The Stone Street Master Plan will be the subject of a Certificate of Appropriateness determination at the same public hearing as these Rules.

The Rules set forth herein will permit the LPC staff to issue Authorizations to Proceed letters ("ATP") for work that complies with the approved Stone Street Master Plan. The goal of these Rules is to encourage appropriate repair, rehabilitation, replacement and alterations in the Stone Street Historic District by expediting the process of obtaining permits to perform such work. Work that is not in accordance with the Stone Street Master Plan will be reviewed by the Commission in accordance with its usual review procedures as set forth in the Landmarks Law.

(b) Definitions

As used in these Rules, the following terms shall have the following meanings:

"Authorization to Proceed" and "ATP" shall mean an authorization to proceed as described in section 12-01(f) of these Rules.

"Commission" shall mean the eleven Commissioners, including the Chairman, as established by Section 3020 of the New York City Charter.

"District Master Plan" shall have the meaning set forth in section 12-01 of these Rules.

"Landmarks Law" shall refer to Section 3020 of the New York City Charter and Chapter 3 of Title 25 of the Administrative Code of the City of New York.

"LPC" shall mean the Landmarks Preservation Commission acting in its agency capacity to implement the Landmarks Law.

"Stone Street Master Plan" shall mean the District Master Plan for the Stone Street Historic District and approved by the Commission as a Certificate of Appropriateness. Copies of the Stone Street Master Plan may be obtained by contacting the Commission's Public Information Specialist at (212) 487-6782 or by writing to the same at 100 Old Slip, New York, New York, 10005.

Terms not otherwise defined in these rules shall have the meanings given them in the Landmarks Law.

(c) Eligible Buildings. The buildings located within the Stone Street Historic District are subject to these Rules.

(d) Permitted Alterations Pursuant to the Stone Street Master Plan. The LPC staff shall issue an ATP for work on eligible buildings within the Stone Street Historic District if the staff determines that: (1) the proposed work meets the criteria set forth in the in the Stone Street Master Plan; and (2) the staff determines that the proposed work will not adversely affect any significant exterior architectural feature of the eligible building or the Stone Street Historic District.

(e) Application Procedures

(1) Submission of Application. See Chapter 2, Subchapter A ("Application Procedure") and Chapter 12 of these Rules.

(2) Application Materials. The applicant must submit adequate materials that clearly set forth the scope and details of the proposed work. At a minimum, the applicant must submit detailed drawings that specifically show the proposed work and all other materials required by the LPC staff. Drawings must be made to scale, and include all pertinent dimensions. LPC staff may require applicants to submit other materials, including but not limited to photographs of existing conditions, construction details, material samples, specifications, or maps as necessary to clearly explain the proposed work. LPC staff may also require probes or other investigations to determine the existing conditions and critical dimensions peculiar to each eligible building.

(f) Review Procedure.

(1) The application will be deemed complete when the LPC staff determines that adequate materials have been submitted that clearly set forth the scope and details of the proposed work.

(2) When the application is complete, LPC staff will review the application for conformity with these Rules. Upon determination that the criteria of the Rules have been met, an ATP will be issued pursuant to section 12-01(f). A determination that an ATP should be issued shall mean that the proposed work satisfies the criteria set forth in the Stone Street Master Plan and that the work is appropriate to or will have no effect on protected architectural features of the specific eligible building in question and is otherwise appropriate to the Stone Street Historic District.

(3) If the criteria set forth in these rules for an ATP have not been met, the LPC staff shall provide the applicant with a notice of the proposed denial of the application. The applicant may request a meeting with the Director of the Preservation Department, or, in the absence of the Director, with a Deputy Director, to discuss the interpretation of these Rules.

(4) Applications for work that do not qualify for the issuance of an ATP in accordance with these Rules shall be subject to the LPC's usual review procedure as set forth in the Landmarks Law.

12-03 IMPLEMENTATION RULES FOR THE DISTRICT MASTER PLAN FOR STOREFRONTS ON MADISON AVENUE IN THE UPPER EAST SIDE HISTORIC DISTRICT (Effective December 29, 2000)

(a) Introduction

The implementation rules (“Rules”) for the District Master Plan for Storefronts on Madison Avenue in the Upper East Side Historic District ("District Master Plan") are promulgated to assist building owners in applying to the Landmarks Preservation Commission ("LPC") for approval of applications to undertake repair, rehabilitation, replacement, or alterations to storefronts (including but not limited to storefront infill, lighting, signage, security gates, windows and doors) along Madison Avenue within the Upper East Side Historic District that are in accordance with the District Master Plan approved by the Commission. The rules set forth herein permit the LPC staff to issue Authorizations to Proceed letters ("ATP") for work that complies with the approved District Master Plan. Work that is not in accordance with the requirements of the District Master Plan will be reviewed by the Commission in accordance with its usual review procedures under the Landmarks Law.

The objective of the District Master Plan is to provide owners, architects and store tenants with design criteria which will allow timely review of storefront alterations while protecting the architecturally and historically significant features of the buildings. The District Master Plan will cover buildings on Madison Avenue that fall within the Upper East Side Historic District. Additionally, at corner buildings the District Master Plan will cover the building facades facing both Madison Avenue and the side streets.

(b) Definitions

As used in these Rules, the following terms shall have the following meanings:

"Authorization to Proceed" and "ATP" shall mean an authorization to proceed as described in section 12-01(f) of these Rules.

"Commission " shall mean the eleven Commissioners, including the Chairman, as established by Section 3020 of the New York City Charter.

"District Master Plan" shall mean the District Master Plan for Storefronts on Madison Avenue in the Upper East Side Historic District and approved by the Commission as a Certificate of Appropriateness. A copy of the District Master Plan may be reviewed at the offices of the Commission by appointment.

"Landmarks Law" shall refer to Section 3020 of the New York City Charter and Chapter 3 of Title 25 of the Administrative Code of the City of New York.

"LPC" shall mean the Landmarks Preservation Commission acting in its agency capacity to implement the Landmarks Law.

Terms not otherwise defined in these rules shall have the meanings given them in the Landmarks Law.

(c) Eligible Buildings. As specifically set forth and described in the District Master Plan, these Rules shall cover buildings facing Madison Avenue and located within the Upper East Side Historic District, including the commercial portions of a building facing onto both Madison Avenue and a side street.

(d) Permitted Alterations Pursuant to the District Master Plan. The LPC staff shall issue an ATP for work on storefronts in eligible buildings along Madison Avenue if the staff determines that:

(1) The proposed work meets the design criteria for storefront alterations as set forth in the District Master Plan; and

(2) The staff determines that the proposed work would not adversely affect any significant architectural feature of the building.

(e) Application Procedures

(1) Submission of Application. See Chapter 2, Subchapter A ("Application Procedure") and Chapter 12 of these Rules.

(2) Application Materials. The applicant shall submit adequate materials that clearly set forth the scope and details of the proposed work. At a minimum, the applicant shall submit detailed drawings that specifically show the proposed work and all other materials required by the LPC staff. Drawings shall be made to scale, and include all pertinent dimensions. LPC staff may require applicants to submit other materials, including but not limited to photographs of existing conditions, construction details, material samples, specifications, or maps as necessary to clearly explain the proposed work. LPC staff may also require probes or other investigations to determine the existing conditions and critical dimensions peculiar to each eligible building storefront.

(3) Review Procedure.

(i) The application will be deemed complete when the LPC staff determines that adequate materials have been submitted that clearly set forth the scope and details of the proposed work.

(ii) When the application is complete, LPC staff will review the application

for conformity with these Rules. Upon determination that the criteria of the Rules have been met, an ATP will be issued pursuant to section 12-01(f). A determination that an ATP should be issued shall mean that the proposed work satisfies the criteria of the District Master Plan and that the work is appropriate to or will have no effect on protected architectural features of the specific eligible building in question and is otherwise appropriate to the Upper East Side Historic District.

(iii) If the LPC staff determines that the criteria set forth in these Rules have not been met, the LPC staff shall provide the applicant with a notice of the proposed denial of the application. The applicant may request a meeting with the Director of the Preservation Department, or, in the absence of the Director, with a Deputy Director, to discuss the determination.

(iv) Applications for work that do not qualify for the issuance of an ATP in accordance with these Rules shall be subject to the LPC's usual review procedure as set forth in the Landmarks Law.

12-04 IMPLEMENTATION RULES FOR THE DISTRICT MASTER PLAN FOR STOREFRONTS ON MADISON AVENUE IN THE METROPOLITAN MUSEUM HISTORIC DISTRICT (Effective December 29, 2000)

(a) Introduction

The implementation rules ("Rules") for the District Master Plan for Storefronts on Madison Avenue in the Metropolitan Museum Historic District ("District Master Plan") are promulgated to assist building owners in applying to the Landmarks Preservation Commission ("LPC") for approval of applications to undertake repair, rehabilitation, replacement, or alterations to storefronts (including but not limited to storefront infill, lighting, signage, security gates, windows and doors) along Madison Avenue within the Metropolitan Museum Historic District that are in accordance with the District Master Plan approved by the Commission. The rules set forth herein permit the LPC staff to issue Authorizations to Proceed letters ("ATP") for work that complies with the approved District Master Plan. Work that is not in accordance with the requirements of the District Master Plan will be reviewed by the Commission in accordance with its usual review procedures under the Landmarks Law.

The objective of the District Master Plan is to provide owners, architects and store tenants with design criteria which will allow timely review of storefront alterations while protecting the architecturally and historically significant features of the buildings. The District Master Plan will cover buildings on Madison Avenue that fall within the Metropolitan Museum Historic District. Additionally, at corner buildings the District Master Plan will cover the building facades facing both Madison Avenue and the side streets.

(b) Definitions

As used in these Rules, the following terms shall have the following meanings:

"Authorization to Proceed" and "ATP" shall mean an authorization to proceed as described in section 12-01(f) of these Rules.

"Commission " shall mean the eleven Commissioners, including the Chairman, as established by Section 3020 of the New York City Charter.

"District Master Plan" shall mean the District Master Plan for Storefronts on Madison Avenue in the Metropolitan Museum Historic District and approved by the Commission as a Certificate of Appropriateness. A copy of the District Master Plan may be reviewed at the offices of the Commission by appointment.

"Landmarks Law" shall refer to Section 3020 of the New York City Charter and Chapter 3 of Title 25 of the Administrative Code of the City of New York.

"LPC" shall mean the Landmarks Preservation Commission acting in its agency capacity to implement the Landmarks Law.

Terms not otherwise defined in these rules shall have the meanings given them in the Landmarks Law.

(c) Eligible Buildings. As specifically set forth and described in the District Master Plan, these Rules shall cover buildings facing Madison Avenue and located within the Metropolitan Museum Historic District, including the commercial portions of a building facing onto both Madison Avenue and a side street.

(d) Permitted Alterations Pursuant to the District Master Plan. The LPC staff shall issue an ATP for work on storefronts in eligible buildings along Madison Avenue if the staff determines that:

(1) The proposed work meets the design criteria for storefront alterations as set forth in the District Master Plan; and

(2) The staff determines that the proposed work would not adversely affect any significant architectural feature of the building.

(e) Application Procedures

(1) Submission of Application. See Chapter 2, Subchapter A ("Application Procedure") and Chapter 12 of these Rules.

(2) Application Materials. The applicant shall submit adequate materials that clearly set forth the scope and details of the proposed work. At a minimum, the applicant shall submit detailed drawings that specifically show the proposed work and all other materials required by the LPC staff. Drawings shall be made to scale, and include all pertinent dimensions. LPC staff may require applicants to submit other materials, including but not limited to photographs of existing conditions, construction details, material samples, specifications, or maps as necessary

to clearly explain the proposed work. LPC staff may also require probes or other investigations to determine the existing conditions and critical dimensions peculiar to each eligible building storefront.

(3) Review Procedure.

(i) The application will be deemed complete when the LPC staff determines that adequate materials have been submitted that clearly set forth the scope and details of the proposed work.

(ii) When the application is complete, LPC staff will review the application for conformity with these Rules. Upon determination that the criteria of the Rules have been met, an ATP will be issued pursuant to section 12-01(f). A determination that an ATP should be issued shall mean that the proposed work satisfies the criteria of the District Master Plan and that the work is appropriate to or will have no effect on protected architectural features of the specific eligible building in question and is otherwise appropriate to the Metropolitan Museum Historic District.

(iii) If the LPC staff determines that the criteria set forth in these Rules have not been met, the LPC staff shall provide the applicant with a notice of the proposed denial of the application. The applicant may request a meeting with the Director of the Preservation Department, or, in the absence of the Director, with a Deputy Director, to discuss the determination.

(iv) Applications for work that do not qualify for the issuance of an ATP in accordance with these Rules shall be subject to the LPC's usual review procedure as set forth in the Landmarks Law.

12-05 IMPLEMENTATION RULES FOR THE DISTRICT MASTER PLAN FOR STOREFRONTS ON MADISON AVENUE IN THE CARNEGIE HILL (AND EXTENSION) HISTORIC DISTRICT (Effective December 29, 2000)

(a) Introduction

The implementation rules ("Rules") for the District Master Plan for Storefronts on Madison Avenue in the Carnegie Hill (and Extension) Historic District ("District Master Plan") are promulgated to assist building owners in applying to the Landmarks Preservation Commission ("LPC") for approval of applications to undertake repair, rehabilitation, replacement, or alterations to storefronts (including but not limited to storefront infill, lighting, signage, security gates, windows and doors) along Madison Avenue within the Carnegie Hill (and Extension) Historic District that are in accordance with the District Master Plan approved by the Commission. The rules set forth herein permit the LPC staff to issue Authorizations to Proceed letters ("ATP") for work that complies with the approved District Master Plan. Work that is not in accordance with the requirements of the District Master Plan will be reviewed by the Commission in accordance with its usual review procedures under the Landmarks Law.

The objective of the District Master Plan is to provide owners, architects and store tenants with design criteria which will allow timely review of storefront alterations while protecting the architecturally and historically significant features of the buildings. The District Master Plan will cover buildings on Madison Avenue that fall within the Carnegie Hill (and Extension) Historic District. Additionally, at corner buildings the District Master Plan will cover the building facades facing both Madison Avenue and the side streets.

(b) Definitions

As used in these Rules, the following terms shall have the following meanings:

"Authorization to Proceed" and "ATP" shall mean an authorization to proceed as described in section 12-01(f) of these Rules.

"Commission " shall mean the eleven Commissioners, including the Chairman, as established by Section 3020 of the New York City Charter.

"District Master Plan" shall mean the District Master Plan for Storefronts on Madison Avenue in the Carnegie Hill (and Extension) Historic District and approved by the Commission as a Certificate of Appropriateness. A copy of the District Master Plan may be reviewed at the offices of the Commission by appointment.

"Landmarks Law" shall refer to Section 3020 of the New York City Charter and Chapter 3 of Title 25 of the Administrative Code of the City of New York.

"LPC" shall mean the Landmarks Preservation Commission acting in its agency capacity to implement the Landmarks Law.

Terms not otherwise defined in these rules shall have the meanings given them in the Landmarks Law.

(c) Eligible Buildings. As specifically set forth and described in the District Master Plan, these Rules shall cover buildings facing Madison Avenue and located within the Carnegie Hill (and Extension) Historic District, including the commercial portions of a building facing onto both Madison Avenue and a side street.

(d) Permitted Alterations Pursuant to the District Master Plan. The LPC staff shall issue an ATP for work on storefronts in eligible buildings along Madison Avenue if the staff determines that:

(1) The proposed work meets the design criteria for storefront alterations as set forth in the District Master Plan; and

(2) The staff determines that the proposed work would not adversely affect any significant architectural feature of the building.

(e) Application Procedures

(1) Submission of Application. See Chapter 2, Subchapter A ("Application Procedure") and Chapter 12 of these Rules.

(2) Application Materials. The applicant shall submit adequate materials that clearly set forth the scope and details of the proposed work. At a minimum, the applicant shall submit detailed drawings that specifically show the proposed work and all other materials required by the LPC staff. Drawings shall be made to scale, and include all pertinent dimensions. LPC staff may require applicants to submit other materials, including but not limited to photographs of existing conditions, construction details, material samples, specifications, or maps as necessary to clearly explain the proposed work. LPC staff may also require probes or other investigations to determine the existing conditions and critical dimensions peculiar to each eligible building storefront.

(3) Review Procedure.

(i) The application will be deemed complete when the LPC staff determines that adequate materials have been submitted that clearly set forth the scope and details of the proposed work.

(ii) When the application is complete, LPC staff will review the application for conformity with these Rules. Upon determination that the criteria of the Rules have been met, an ATP will be issued pursuant to section 12-01(f). A determination that an ATP should be issued shall mean that the proposed work satisfies the criteria of the District Master Plan and that the work is appropriate to or will have no effect on protected architectural features of the specific eligible building in question and is otherwise appropriate to the Carnegie Hill (and Extension) Historic District.

(iii) If the LPC staff determines that the criteria set forth in these Rules have not been met, the LPC staff shall provide the applicant with a notice of the proposed denial of the application. The applicant may request a meeting with the Director of the Preservation Department, or, in the absence of the Director, with a Deputy Director, to discuss the determination.

(iv) Applications for work that do not qualify for the issuance of an ATP in accordance with these Rules shall be subject to the LPC's usual review procedure as set forth in the Landmarks Law.

12-06 IMPLEMENTATION RULES FOR THE DISTRICT MASTER PLAN FOR THE DOUGLASTON HISTORIC DISTRICT (Effective July 22, 2003)

(a) Introduction

The implementation rules ("Rules") for The District Master Plan for the Douglaston

Historic District (“District Master Plan”) are promulgated to assist building owners in applying to the Landmarks Preservation Commission (“LPC”) for approval of applications to undertake various types of work on properties located within the Douglaston Historic District, including additions, outbuildings, window replacement, heating, venting and air conditioning, and work on or affecting significant landscape improvements. The rules set forth herein permit the LPC staff to issue Authorizations to Proceed (“ATP”) for work that complies with the approved District Master Plan. Work that is not in accordance with the requirements of the District Master Plan will be reviewed by the Commission in accordance with its usual review procedures under the Landmarks Law.

The objective of the District Master Plan is to provide owners, architects and store tenants with design criteria which will allow timely review of proposed alterations while protecting the architecturally and historically significant features of the buildings and historic district’s sense of place. The District Master Plan will cover all buildings in the Douglaston Historic District.

(b) Definitions

As used in these Rules, the following terms shall have the following meanings:

"Authorization to Proceed" and "ATP" shall mean an authorization to proceed as described in section 12-01(f) of these Rules.

"Commission" shall mean the appointed Commissioners, including the Chairman, acting as the Landmarks Preservation Commission as established by Section 3020 of the New York City Charter.

"District Master Plan" shall mean the District Master Plan for the Douglaston Historic District approved by the Commission as a Certificate of Appropriateness. A copy of the District Master Plan may be reviewed at the offices of the Commission by appointment.

"Landmarks Law" shall refer to Section 3020 of the New York City Charter and Chapter 3 of Title 25 of the Administrative Code of the City of New York.

“Landscape Improvement” shall mean a physical betterment of real property or any part thereof, consisting of natural or artificial landscape, including but not limited to grade, body of water, hedge, mature tree, walkway, road, plaza, wall, fence, step, fountain, or sculpture.

"LPC" shall mean the Landmarks Preservation Commission acting in its agency capacity to implement the Landmarks Law.

Terms not otherwise defined in these rules shall have the meanings given them in the Landmarks Law.

(c) Eligible Buildings. All buildings in the Douglaston Historic District are subject to the

District Master Plan.

(d) Permitted Alterations. The LPC staff shall issue an ATP if the staff determines that:

(1) The proposed work meets the criteria set forth in the District Master Plan; and

(2) The proposed work will not adversely affect any significant architectural feature of the building or significant Landscape Improvement, not otherwise permitted by the District Master Plan or other LPC approval.

(e) Application Procedures

(1) Submission of Application. See Chapter 2, Subchapter A ("Application Procedure") and Chapter 12 of these Rules.

(2) Application Materials. The applicant shall submit adequate materials that clearly set forth the scope and details of the proposed work. At a minimum, the applicant shall submit detailed drawings that specifically show the proposed work and all other materials required by the LPC staff. Drawings shall be made to scale, and include all pertinent dimensions. LPC staff may require applicants to submit other materials, including but not limited to photographs of existing conditions, construction details, material samples, specifications, or maps as necessary to clearly explain the proposed work. LPC staff may also require mockups of proposed additions or outbuildings to determine the visibility of such additions or outbuildings, and probes or other investigations to determine existing conditions.

(3) Review Procedure.

(i) The application will be deemed complete when the LPC staff determines that the materials submitted adequately and clearly set forth the scope and details of the proposed work.

(ii) When the application is complete, LPC staff will review the application for conformity with these Rules. Upon determination that the criteria of the Rules have been met, an ATP will be issued pursuant to section 12-01(f). A determination that an ATP should be issued shall mean that the proposed work satisfies the criteria of the District Master Plan and that the work is appropriate to or will have no effect on protected architectural features of the specific building in question and is otherwise appropriate to the Douglaston Historic District.

(iii) If the LPC staff determines that the criteria set forth in these Rules have not been met, the LPC staff shall provide the applicant with a notice of the proposed denial of the application. The applicant may request a meeting with the Director of the Preservation Department, or, in the absence of the Director, with a Deputy Director, to discuss the determination.

(iv) Applications for work that do not qualify for the issuance of an ATP in accordance with these Rules shall be subject to the LPC's usual review procedure as set forth in the Landmarks Law.

Chapter 13. Fees

§ 13-01. Requirement of fee. All applicants for a certificate of appropriateness or a certificate of no effect shall pay a fee, as established in accordance with the provisions of this Chapter, except that no fees shall be payable by an owner of the designated building or property affected if the owner is a corporation or association organized and operated exclusively for religious, charitable or educational purposes, or for one or more such purposes, no part of the earnings of which enures to the benefit of any private shareholder or individual, and provided that the property affected is used exclusively by such corporation or association for one or more of such purposes.

§ 13-02. Fee for approval and consideration of applications. The fees required to be paid under this Chapter are for filing and processing of applications for certificates of appropriateness and certificates of no effect. The total fee for such work shall be paid by or on behalf of the owner or lessee of the designated building or property before the Department of Buildings issues a work permit or other approval for such work approved in the certificate of appropriateness or certificate of no effect. The fees required to be paid under this Chapter shall be payable each time the owner or lessee of the designated building or property shall apply for a permit or approval from the Department of Buildings for work approved in a certificate of appropriateness or certificate of no effect.

§ 13-03. Definitions

“Administrative Code” shall mean the Administrative Code of the City of New York

“Designated building or property” shall mean an improvement designated as a landmark, interior landmark or as part of a historic district, and the landmark site(s) associated with such designation, pursuant to section 25-303 of the Administrative Code.

§ 13-04 Computation of fees. Fees shall be computed as hereinafter provided:

(a) New buildings. The fees for permits to construct new buildings shall be computed as follows:

(1) a fee of thirteen cents per square foot or fraction thereof, but not less than one hundred dollars per structure, for work subject to a fee payable to the Department of Buildings pursuant to Section 26-212(1)(a) of the Administrative Code.

(2) a fee of six cents per square foot, or fraction thereof, but not less than one hundred dollars per structure, for work subject to a fee payable to the Department of Buildings pursuant to Section 26-212(1)(b) of the Administrative Code.

(b) Building alterations. A fee of fifty dollars for the first twenty-five thousand dollars, or fraction thereof, of the cost of the work and three dollars for each additional one thousand

dollars, or fraction thereof, of cost over twenty-five thousand dollars for work subject to a fee payable to the Department of Buildings pursuant to Sections 26-212(1)(c), 26-212(1)(d), 26-212(2)(a), 26-212(2)(b), and 26-212(3) of the Administrative Code.

(c) Demolition and removal. A fee computed by multiplying the street frontage in feet by the number of stories of the building times one dollar, but not less than one hundred dollars, shall be paid for work subject to a fee payable to the Department of Buildings pursuant to Section 26-212(4) of the Administrative Code.

(d) Signs. A fee of one hundred dollars to erect, install or alter a sign shall be paid for each sign subject to a fee payable to the Department of Buildings pursuant to Section 26-212(6)(a). An additional fee shall be payable for signs as follows:

(1) A fee of fifty dollars shall be paid for each ground sign subject to a fee pursuant to section 26-212(6)(a)(1) of the Administrative Code.

(2) A fee of fifty dollars shall be paid for each roof sign having a tight, closed or solid surface, where such sign is subject to a fee pursuant to section 26-212(6)(a)(2) of the Administrative Code.

(3) A fee of fifty dollars shall be paid for each roof sign that does not have a tight, closed or solid surface and where such sign does not extend beyond thirty-one feet above the roof level, where such sign is subject to a fee pursuant to section 26-212(6)(a)(3) of the Administrative Code. A fee of one hundred shall be paid for each roof sign that exceeds thirty-one feet above the roof level.

§ 13-05. Effective Date. The fees required pursuant to this Chapter shall apply to certificates of appropriateness and certificates of no effect issued on or after July 1, 2004.