

FIRE DEPARTMENT • CITY OF NEW YORK



**STUDY MATERIAL FOR THE EXAMINATION FOR
THE CERTIFICATE OF FITNESS FOR
STANDPIPE SYSTEM**

**S-13 City Wide Standpipe System
(Excludes personal supervision of Multi-zone systems)
And
S-14 Standpipe for Multi-zone System
(Personal supervision of multi-zone systems F.C.905.1.1)**

ALSO INCLUDED IN THIS BOOKLET YOU WILL FIND THE FOLLOWING:

NOTICE OF EXAMINATION (NOE)

© 03-08-2011 New York City Fire Department - All rights reserved ®

TABLE OF CONTENTS

TABLE OF CONTENTS 2

NOTICE OF EXAMINATION..... 4

STUDY MATERIAL AND TEST DESCRIPTION 5

PART 1: INTRODUCTION 6

PART 2: RESPONSIBILITY OF THE BUILDING OWNER 7

PART 3: OUT OF SERVICE SYSTEMS (OOS) 7

PART 4: PROCEDURE FOR DETAIL RECORD KEEPING, IMPAIRMENTS & SAFETY10

PART 5: INDIVIDUALS AUTHORIZED TO PERFORM TASKS AS PER NYC FIRECODE.....11

PART 6: DEFINITIONS.....11

PART 7: DIFFERENT TYPES OF STANDPIPE SYSTEMS16

 7.1 OVERVIEW OF STANDPIPE SYSTEMS..... 16

 7.2 CLASSES OF STANDPIPES SYSTEMS..... 16

 7.3 WET STANDPIPE SYSTEM 17

 7.4 DRY STANDPIPE WITH AN AUTOMATIC DRY PIPE VALVE (MANUAL STANDPIPE)..... 17

 7.5 DRY STANDPIPE WITH A MANUAL CONTROL VALVE..... 18

 7.7 YARD SYSTEMS 18

 7.8 COMBINATION / COMBINED SYSTEMS 20

PART 8: STANDPIPE SYSTEM COMPONENTS.....20

 8.1 ROOF MANIFOLD 20

 8.2 FIRE DEPARTMENT CONNECTION 21

 8.3 ALARMS AND SUPERVISORY SIGNAL DEVICES 23

 8.4 DIFFERENT TYPE OF VALVES 24

 8.4.1 CHECK VALVES 24

 8.4.2 SWING CHECK VALVES 24

 8.4.3 ALARM CHECK VALVES 25

 8.5.2 OS & Y (OUTSIDE SCREW AND YOKE) 25

 8.5 FIRE HOSE INCLUDING COUPLINGS AND NOZZLES 26

 8.5.1 FIRE HOSE OUTLET AND RELEASE RACK 26

 8.5.2 HOSE CABINETS AND STORAGE 27

 8.5.3 NOZZLES 28

 8.5.4 HOSE RECORDS (OCCUPANT-USE HOSE) 28

 8.5.5 OCCUPANT-USE HOSE 30

PART 9: WATER SUPPLY30

 9.1 PRESSURE TANKS 31

 9.2 GRAVITY TANKS 33

 9.3 FIRE PUMPS 36

 9.4 THE CENTRIFUGAL PUMP 36

 9.5 THE VERTICAL TURBINE PUMP 37

PART 10: INSPECTION, TESTING AND MAINTENANCE.....40

 10.1 A COMPLETE SUMMARY OF TASKS OF INSPECTION, TESTING & MAINTENANCE 42

 10.2 INSPECTION REFERENCE GUIDE..... 54

 10.3 TESTING REFERENCE GUIDE..... 58

 10.4 MAINTENANCE REFERENCE GUIDE 60

 10.5 INSPECTION, MAINTENANCE & TESTING NOTIFICATION ACTIVITIES 62

PART 11: SIGNAGE REQUIREMENTS70

 11.1 FIRE DEPARTMENT CONNECTION SIGN 70

 11.2 CONTROL VALVE SIGN 70

11.4 FIRE DEPARTMENT CONNECTIONS SERVING A STANDPIPE SYSTEM SIGN 70
11.5 SUPPLY HOSE SIGN 71
11.6 STAIRWAYS WITHOUT HOSE CONNECTIONS SIGN 71

PART 12: NYC BUILDING LOCAL LAW 58 OF 200972

PART 13: FIRE DEPARTMENT CODE AND RULES CHAPTER 976

13.1 FIRE DEPARTMENT CODE SECTION 905 STANDPIPE SYSTEM 76
13.2 FIRE DEPARTMENT RULES § 905-01 STANDPIPE SYSTEM 77

NOTICE OF EXAMINATION

Title: Examination for the C of F for S-13 City Wide Standpipe System and S-14 Standpipe for Multi-zone System

Date of Test: Written tests are conducted Monday through Friday (except legal holidays) 8:00 AM to 2:30 PM.

QUALIFICATION REQUIREMENTS

1. Applicants must be at least 18 years of age.
2. Applicants must have a reasonable understanding of the English language.
3. Applicant must present a letter of recommendation from his/her employer. The letter must be on official letterhead and must state the applicant's full name, character, physical condition, experience, and address of premises where applicant will be employed.
4. Applicant must provide two forms of government issued photo identification, such as a State-issued Drivers' License or Non Drivers License or a passport.
5. New applicants taking Standpipe System will take the new S-13 or S-14 test. Currently holder of standpipe/sprinkler certificates will not have their C of F renewed and must take this new test.

Application Fees: \$25.00 for originals and \$15.00 for renewals. The fee may be paid by credit card (no debit), in cash, money order or personal check payable to New York City Fire Department. The \$25.00 fee must be payable by all applicants prior to taking the C of F test. Application forms are available at the Public certification Unit, 1st floor, 9 Metro Tech Center, Brooklyn, NY 11201.

Renewal requirements:

1. Send the renewal coupon or a letter stating C of F #.
2. The fee \$15, money order or personal check payable to New York City Fire Department
3. To FDNY (Cashier Unit)
9 Metro Tech Center, Brooklyn, NY 11201

TEST INFORMATION

Test: The test will be of the written, multiple choice type. A passing score of at least 70% is required in order to obtain a C of F. Call 718-999-1988 or 2504 for additional information and forms.

Study Material and Test Description

About the booklet

This study material will help you prepare for the written examination for the Certificate of Fitness (**C of F**) for Standpipe Systems. The study materials include information taken from the New York City Fire Code (FC) Chapter 9 and Fire Department Rules Chapter 9 and NFPA Standard 25, 2002 Edition Inspection, Testing and Maintenance of Water based Fire Protection Systems. **It is critical that you read AND understand this booklet to help increase your chance of passing this exam.**

About the Test

You must pass a multiple choice test to qualify for the C of F. A score of 70% correct is required in order to pass the test. All questions have four answer options. Only **one** answer is correct for each question. If you do not answer a question, or if you mark more than one answer to a single question, your answer to that question will be scored as incorrect. Read each question carefully before marking your answer. There is no penalty for guessing.

Sample Questions

1. Which one of the following statements is best describes the picture shown below?



- (A) Gravity Tank.
- (B) Fire department connection.
- (C) Standpipe fire hose.
- (D) Sprinkler System.

The correct answer is "**A**". You would mark "**A**" on your touch-screen terminal.

2. What sports team plays at Madison Square Garden?

- (A) Yankees.
- (B) Mets.
- (C) Cardinals.
- (D) Knicks.

The correct answer is "**D**". You would mark "**D**" on your touch-screen terminal.

PART 1: INTRODUCTION

A standpipe system is piping installed in a building that serves to transfer water to hose connections located within the building for firefighting purposes. Whether a building must be provided with standpipe system or not is generally set forth in the NYC Building Code, however the Fire Code does contain several standpipe requirements, such as for high piled combustible storage and for buildings constructed on streets of substandard width. inspection, testing, servicing and other maintenance of standpipe systems must be personally supervised (FC 905.1.1) and be performed in accordance with NFPA (National Fire Protection Association) NFPA 25, 2002 edition and NFPA 1962, 1998 edition for the Care, Use, and Service Testing of Fire Hose Including Couplings and Nozzles.

All multiple dwellings, factories, office buildings, warehouses, stores and offices, theaters and music halls, hospitals and asylums, public schools and other public buildings, churches and other places where large numbers of persons are congregated for purposes of worship, instruction or amusement, and all piers, bulkheads, wharves, pier sheds, bulkhead sheds or other waterfront structures shall provide such fire hose, fire extinguishers, buckets, axes, fire hooks, fire doors and other means of preventing and extinguishing fires as the commissioner may direct.

Required fire protection systems shall be extended or altered as necessary to maintain and continue protection whenever the building or structure is altered (FC 901.4.1). Systems not complying with this section shall be considered to be impaired. It shall be unlawful to install or maintain any fire protection system or device that has the physical appearance of fire protection equipment but that does not perform a fire protection function where it may be confused with actual fire protection equipment.(FC 901.6.3) An example would be a CCTV camera modeled to look like sprinkler head.



PART 2: RESPONSIBILITY OF THE BUILDING OWNER

It shall be the owner's responsibility to maintain the Standpipe system and to determine the individual qualifications and competencies of the individual his C of F holder to perform certain functions related to inspection, testing and maintenance.

901.6.2 Records. Records of all system inspections, tests, servicing and other maintenance required by this code, the rules or the referenced standards shall be maintained on the premises for a minimum of 3 years and made available for inspection by any department representative.

901.7.1 Impairment coordinator. The building owner shall assign an impairment coordinator to comply with the requirements of this section. In the absence of a specific designee, the owner shall be considered the impairment coordinator.

The building owner or their agent shall assign an impairment coordinator to maintain records of all system inspections, tests, servicing and other items of maintenance **on premise** for a period of three years and made available for inspection by any member of the FDNY. In absence of a specific designee, the building owner shall be considered the impairment coordinator (FC 901.7.1).

Part 3: OUT OF SERVICE SYSTEMS (OOS)

Planned removal from service: When the system, or a portion of the standpipe system, is placed out of service for a scheduled inspection, testing, regular maintenance, minor repairs or for construction affecting not more than 1 floor, the C of F holder and the impairment coordinator shall be made aware of and authorize the placing of the system out of service.

Unplanned out of service condition: A serious defect in the standpipe system including, but not limited to: an empty tank, a break or major leak in the system's water piping, inoperative or shut water supply valves, defective fire department connections, construction related shut downs affecting more than one floor, or complete or partial shut downs of the standpipe system, other than a shut down for a planned removal from service.

Minor defects observed by the C of F holder shall be reported to the owner. Orange and yellow deficiencies if not corrected with 30 days it shall be deemed to be impairment and reported in writing to the Fire Department (FC 901.7.5).

Fire Department Notifications For Out of Service Conditions:

- a) For a planned removal from service, as described above, no notification to the Fire Department is required provided the system will be returned to service within an 8

hour period and when all other fire protection systems in the building (standpipes and alarm systems) are fully operational.

- b) For an unplanned removal from service as described above, the C of F holder, impairment coordinator, and/or other person responsible for inspecting, maintaining or supervising the operation of a fire protection system shall immediately report such condition to the owner of the building and to the FDNY Borough Dispatcher (FC 901.7.5). The telephone numbers are as follows:

Manhattan	212-570-4300
Bronx	718-430-0200
Brooklyn	718-965-8300
Queens	718-476-6200
Staten Island	718-494-4296

- c) The initial Fire Department notification shall include the following:

1. A brief description and extent of the out of service condition.
2. The area of the building affected.
3. The type of occupancy
4. The estimated time the system will be out of service.
5. The name and phone number of the person making the notification.

- d) When the C of F holder observes a minor defect or other condition not presenting a serious safety hazard, he or she shall report the defect or condition to the owner, and if the defect or condition is not corrected within 30 days it shall be deemed to be an impairment and reported in writing to the Fire Department (FC 901.7.5).

Correspondence should be sent via email spkstp@fdny.nyc.gov or by certified documents to:

**New York City Fire Department
Bureau of Fire Prevention
Fire Suppression Unit, 3rd Floor
9 Metro Tech Center
Brooklyn, New York 11201**

Identifying OOS Systems Using Discs/Tags: Systems that are out of service, both planned and unplanned, shall be immediately identified by placing a tag at each of the following locations: fire department connections, system control valves, fire command center or other clearly visible location in the lobby of the building, indicating which system or part thereof is out of service. Impairment coordinators/building owners shall ensure the placement of these tags by MFSPC's or MLP (as restricted) or FDNY units. In addition, for an unplanned out of service condition, a disc (white or blue) shall be placed at all affected fire department connections to inform responding fire department units of the out of service condition. When the condition has been corrected, the disc(s) shall be removed immediately.

Tag Requirement: A tag shall be used to indicate that a system, or portion, is out of service (FC901.7.2). An Impairment coordinator, Owner, Master Fire Protection Piping

Contractor (A or B license), Master Plumber (as restricted) or any authorized person with a proper certificate of fitness from FDNY shall place out of service tags at all required and appropriate locations. This is for planned and unplanned removal of fire protection piping systems from service. The tag shall indicate the area affected, a brief description of the condition, the occupancy classification, and the estimated time until the system becomes operational.

Drain test results shall be posted on the tag indicating both the static and flow pressures before and after the system was placed in an out of service condition.

If no impairment is found in the entire system **green** tags will be placed on the **main control valve**.

Systems Partially or Fully Out of Service: Fire suppression piping systems equipped with Fire Department connections shall follow the following procedures for identifying systems out of service:

Systems Fully Out of Service: The impairment coordinator/building owner shall ensure that the local administrative fire company, Master Fire Suppression Contractor (Class A or B) or MLP's (as restricted) has placed one **White** disc 8 to 9 inches in diameter on all affected fire department connections. **A RED** tag shall be placed at the main control valve indicating the standpipe/sprinkler company name, date of removal from service and anticipated return to service date.

Systems Partially Out of Service: The impairment coordinator/building owner shall ensure that the local administrative fire company, FSPC's or FDNY units Master Fire Suppression Contractor Class A or B has placed one **Blue** Disc 8 to 9 inches in diameter on all affected fire department connections. An **RED** tag shall be placed at the main control valve and any closed sectional valve indicating the company name, date of removal from service and anticipated return to service date.



An Example of FDNY White and Blue Discs

The C of F holder and the impairment coordinator shall be made aware of and authorize the placement of system(s) out of service that are planned to be shut down. The impairment coordinator prior to taking a system out of service shall:

- Determine the duration the system is to be out of service,
- Inspect the areas of the building affected and assess the increased risk,
- Notify the insurance carrier, the central station operator (if so equipped), the occupants of the affected area, and place out of service tags and discs at the appropriate locations (901.7.4).

Impaired Equipment: Underground service mains, water storage tanks, Fire Department connections, control valves, fire and or booster pumps, that are out of service and are considered vital to part of the system that are required to be tagged following procedures outlined in chapter 14 NFPA #25 2002 Ed.

Tags placed at control valves shall indicate the level of impairment for system fully or partially shut down or defect as follows:

	<u>Tag</u>	<u>Disc</u>
System fully out of service	Red	White
System partially out of service	Red	Blue

Only **FDNY, Owner, MFSPC or MLP** (as restricted) may place a white or blue disc on a system. For systems that are fully or partially out of service that are not equipped with Fire Department connections, the appropriate tags shall be placed at the main control valve. FDNY is to be notified immediately.

In a building required by the NYC Fire Code to have a Fire Safety Director with (F-58 or F-25), an Engineer (Q-01 & Q-99) with the S-12, S-13 or S-14 C of F, is authorized to take the system out of the service for less than 8 hrs and place an appropriate colored tag on that system. The FSD and the Engineer must be on the premises at the all times.

Prior to returning a system to service, the impairment coordinator shall ensure that the necessary tests and inspections are conducted to verify that the system is operating normally, notify FDNY borough dispatcher, the building owner’s tenants in the affected area, the insurance carrier, central station operator (if so equipped) and remove out of service tags and discs. (FC 901.7.6)

PART 4: PROCEDURE FOR DETAIL RECORD KEEPING, IMPAIRMENTS & SAFETY

It shall be the responsibility of the C of F holder to perform the following:

Record keeping - The C of F holder shall maintain a detailed record of all inspections. A record card with the date of each inspection, the C of F number, and the signature of the C of F holder shall be posted on the premises near the main water supply control valve.

The detailed inspection report shall include information relative to conditions of water supply, gravity and pressure tanks and levels therein, valves, risers, piping, and Fire Department connections, alarms, fire , booster and special service pumps, obstructions, and conditions of all other system equipment and appurtenances. All defects and/or impairments shall be noted on the report. Records shall be ***readily available*** to any representative of the Fire Department. These records are to be maintained on premise by the building owner for three years.

PART 5: INDIVIDUALS AUTHORIZED TO PERFORM TASKS AS PER NYC FIRECODE

1. **Certificate of Fitness (C of F) for S-13 and/or S-14**-visual inspections only, proper notification and keeping record of inspection results for examination by FDNY.
2. **C of F for S-13* for Refrigeration Operating Engineer (Q-01 & Q-99), NYC High pressure Operating Engineer, NYS High Pressure Operating Engineer** are permitted to perform visual inspections, test notification appliances, perform daily and weekly routine maintenance and record all inspection, testing and maintenance results for examination by FDNY.
***(For employees of a single or multiple properties under common ownership employed by the same building owner/management company)**
3. **C of F holder for S-14** employed by a site-specific building owner with the following certifications: **Refrigeration Operating Engineer (Refrigeration Q-99 & Q-01), High Pressure Operating Engineer and NYS High Pressure Operating Engineer** are permitted to perform visual inspections, test notification appliances, perform daily and weekly routine maintenance and record all inspection, testing and maintenance results for examination by FDNY.
4. **Master Fire Suppression Piping Contractor (MFSPC)** with S-13 C of F can inspect, test, maintain and repair/replace all fire standpipe and sprinkler systems components, record maintenance, inspection and test results for examination and evaluation by FDNY.
5. **Master Plumber (MP)** – with S-13 for Standpipe Systems that are not combined with sprinkler systems. can inspect, test, maintain and repair/replace all fire standpipe systems, record of maintenance, inspection and test results for examination by FDNY.

PART 6: DEFINITIONS

Automatic Standpipe System - A standpipe system that is attached to a water supply

capable of supplying the system demand at all times and that requires no action other than opening a hose valve to provide water at hose connections.

Auxiliary water supply - supplementary source of water for a standpipe and/or sprinkler system.

Control Valve - A valve controlling flow to water-based fire protection systems. Control valves do not include hose valves, inspector's test valves, drain valves, trim valves for dry pipe, pre-action and deluge valves, check valves, or relief valves.

Branch line - A pipe system, generally in a horizontal plane, connecting not more than one hose connection with a standpipe.

Deficiency - A condition in which the application of the component is not within its designed limits or specifications.

Deluge Valve - A water supply control valve intended to be operated by actuation of an automatic detection system that is installed in the same area as the discharge devices. Each deluge valve is intended to be capable of automatic and manual operation. Deluge systems are suitable for hazardous occupancies. This includes buildings in which flammable liquids or other hazardous materials are handled or stored.

Discharge Device - A device designed to discharge water or foam-water solution in a predetermined, fixed, or adjustable pattern. Examples include, but are not limited to, sprinklers, spray nozzles, and hose nozzles.

Dry Standpipe - A standpipe system designed to have piping contain water only when the system is being utilized (No automatic water supply.)

Dunnage - Rooftop dunnage involves designing a raised series of beams (usually steel) bearing on posts or bearing walls to support mechanical equipment (usually on a roof top).

Fire Department Connection - A connection, normally on the exterior of the building, through which the fire department can pump supplemental water into the sprinkler system, standpipe, or other system furnishing water for fire extinguishment to supplement existing water supplies. **(Formerly know as Siamese connection.)**

Fire Hose - A flexible conduit constructed with one or more reinforcements (Jackets), with or without a coating or covering but with an approved nonpermeable lining, or with an inner reinforcement between a protective cover and an approved nonpermeable lining.

Fire Hydrant - A valve connection on a water supply system having one or more outlets and that is used to supply hose and fire department pumps with water.

Fire Pump - A pump that is a provider of liquid flow and pressure dedicated to fire protection. A fire pump is a part of a fire standpipe system's water supply and can be powered by electric, diesel or steam. The pump intake is either connected to the public underground water supply piping or a static water source (e.g., tank, reservoir, lake). The pump provides water flow at higher pressure and volume to the standpipe system risers and hose standpipes.

Fold - A transverse bend (fold) occurring where the hose is lengthwise double over on itself, as on a pin rack.

Gallons per minute (GPM) - typically used to measure fluid flow rate (such as water) or pump capacity. Measurement of water flow rate for a pump or a fire standpipe or sprinkler system.

Hose Connection - a combination of equipment provided for connection of a hose to the standpipe system that includes a hose valve with a threaded outlet.

Hose -

Attack Hose -Hose designed to be used by trained fire fighters and fire brigade members to combat fires beyond the incipient stage.

Booster Hose - A non-collapsible hose used under positive pressure having an elastomeric or thermoplastic tube, a braided or spiraled reinforcement, and an outer protective cover.

Covered Hose - A hose with a jacket covered and lined with a continuous synthetic rubber or plastic. The cover is usually thicker than a coating.

Fire Hose - A flexible conduit used to convey water.

Hose Valve - The valve to an individual hose connection.

Occupant Use Hose - Fire hose designed to be used by the building's occupants to fight incipient fires prior to the arrival of trained fire fighters or fire brigade members.

Unlined Hose - A hose consisting of only a woven jacket that is usually of linen yarns and is of such quality that the yarn swells when wet, tending to seal the hose.

Hose Size - An expression of the internal diameter of the hose.

Hose Station - a combination of a hose rack, hose nozzle, hose, and hose connection.

In Service - The status of hose stored in a hose house, on a rack or reel, or on a fire apparatus that is available and ready for immediate use at an incident. This doesn't include hose in the storage where it is not readily available to be put into service at an incident.

In Storage - A hose that is not readily available for use because it is not at the scene of an incident and not loaded on a vehicle that can transport it to the scene.

In Use - Hose being used during fire suppression or during training.

Impairment Coordinator- The person responsible for ensuring that proper safety precautions are taken when a fire protection system is placed out of service. The building owner shall assign an impairment coordinator to comply with the requirements of this section. In the absence of a specific designee, the owner shall be considered the impairment coordinator.

Labeled - Equipment or materials to which has been attached a label, symbol or other identifying mark or an organization that is acceptable to the authority having jurisdiction and concerned with product evaluation, that maintains periodic inspection of production of labeled equipment or materials, and by whose labeling the manufacturer indicates compliance with appropriate standard or performance in a specified manner.

Listed Device - A fire protection component that has been tested to perform under parameters specified for its use by a nationally recognized testing agency. Underwriter's Laboratory (UL) and Factory Mutual (FM) are the two most common ones.

Manual Standpipe - Standpipe system that relies exclusively on the fire department connection to supply the system demand.

Master Pressure Reducing Valve- A pressure reducing valve installed to regulate pressures in an entire fire protection system and/or standpipe system zone.

Main Drain - The primary drain connection located on the system riser and also utilized as a flow test connection for the automatic sprinkler system.

Nozzles - A device for use in applications requiring special water discharge patterns, directional spray, or other unusual discharge characteristics.

Occupant-Use Hose - Fire Hose designed to be used by the building's occupants to fight incipient fires prior to the arrival of trained fire fighters or fire brigade members.

Out of service system - A fire protection system that is not fully functional; or whose operation is impaired or is otherwise not in good working order.

Personal Supervision - Supervision by the holder of a department certificate who is required to be personally present on the premises, or other proximate location acceptable to the department, while the duties for which the certificate is required is being performed.

Pounds per square inch (PSI) - a unit of pressure measuring force per unit area.

Pressure Control Valve - A pilot operated pressure reducing valve that may be used with a fire or booster pump designed for the purpose of preventing the incoming water supply pressure from dropping below a set pressure.

Pressure Control Valve - A pilot-operated pressure-reducing valve designed for the purpose of reducing the downstream water pressure to a specific value under both flowing (residual) and non flowing (static) conditions.

Pressure-Reducing Valve - A valve designed for the purpose of reducing the downstream water pressure under both flowing (residual) and non flowing (static) conditions.

Pressure Regulating Device - A device designed for the purpose of reducing, regulating controlling, or restricting water pressure. Example includes pressure reducing valve, pressure control valves, and pressure-restricting devices.

Pressure Restricting Device - A valve or device designed for the purpose of reducing of reducing the downstream water pressure under flowing (residual) conditions only.

Pressure Relief Valve - A valve designed for the purpose of releasing excess air or water pressure from the Fire Protection Piping System. Pressure relief valve is not a pressure reducing valve.

Pressure Tank - A tank using air pressure to supplying water for water-based fire protection systems. Tank contents to be maintained at one third air to two thirds water.

Service Test - Hydrostatic test conducted by users on all in-service hose to determine suitability for continued service.

Standpipe System - An arrangement of piping, valves, hose connections, and allied equipment installed in a building or structure, with the hose connections located in such a manner that water can be discharged in streams or spray patterns through attached hose and nozzles, for the purpose of extinguishing a fire, thereby protecting a building or structure and its contents in addition to protecting the occupants.

Piping installed in a building or structure that serves to transfer water from a water supply to hose connections at one or more locations in a building or structure used for firefighting purposes.

Combination Standpipe and Sprinkler System - A system where the fire protection piping services both 2½ in. (65 mm) outlets for fire department use and outlets for automatic sprinklers.

Standpipe, Multi-Zone - A standpipe system that is vertically subdivided as required by the construction codes, including the Building Code, into zones to limit the maximum operating pressure in the system. Each zone will have its own individual automatic water supply.

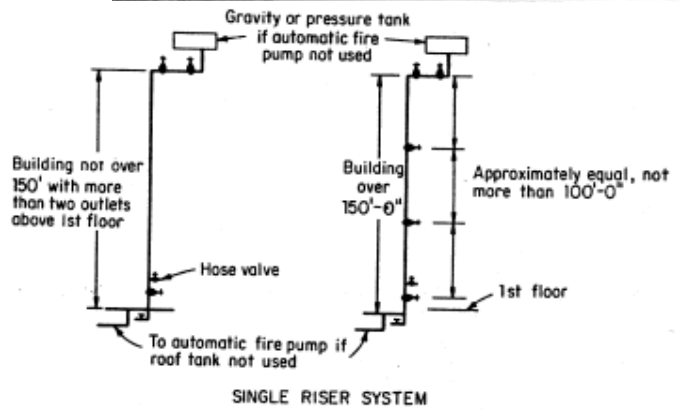
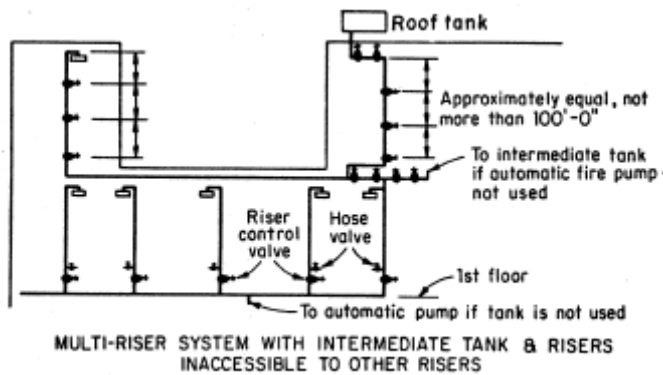
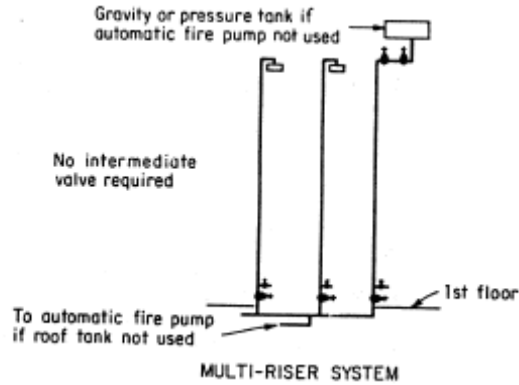
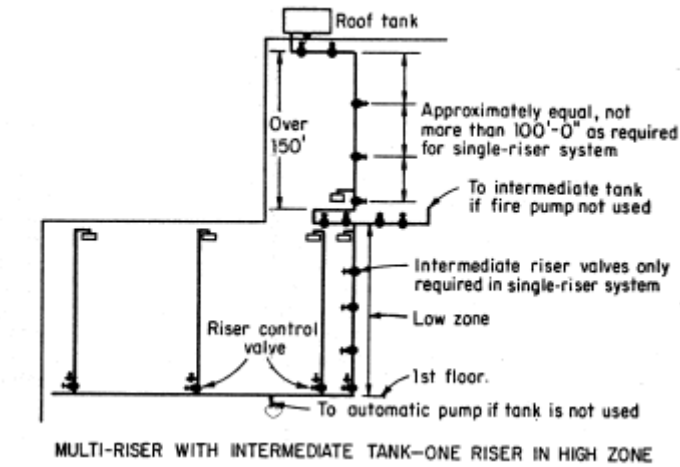

Static Pressure –The measurement of system pressure under non flow conditions

Strainer - A device capable of removing from the water all solids of sufficient size that are obstructing water spray nozzles.

Supervisory signal - signal indicating the need for action in connection with the supervision of guard tours, fire extinguishing systems or equipment, fire alarm systems or the maintenance features of related systems.

Supervisory signal-initiating device - an initiating device, such as a valve supervisory switch, water level indicator, or low-air pressure switch on a dry-pipe system, that triggers a supervisory signal.

Testing - A procedure used to determine the status of a system as intended by conducting periodic physical checks on water based fire protection systems such as water flow tests, fire pump tests, alarm tests, and trip tests of dry pipe or deluge valves. These tests follow the requirements for acceptance testing at intervals specified in the appropriate chapter of NFPA #25, 2002 edition.

Unlined Hose - A hose consisting of only a woven jacket that is usually of linen yarns and is of such quality that yarn swells when wet, tending to seal the hose.

Water Hammer - The surge in pressure when a high-velocity flow of water is abruptly shut off. The pressure exerted by the flowing water against a closed system can be seven or more times that of the static pressure

Water Spray - Water in a form having a predetermined pattern, particle size, velocity, and density discharge from specially designed nozzles or devices.

Water Supply - A source of water that provides the flows [gal/min (L/min)] and pressures [psi (bar)] required by the water-based fire protection system.

Water Tank - A tank supplying water for water-based fire protection systems.

Wet Standpipe System - A standpipe system having piping containing water at all times.

PART 7: DIFFERENT TYPES OF STANDPIPE SYSTEMS

7.1 Overview of Standpipe Systems

Standpipe systems are an important part of the fire protection system in a building. The standpipe system provides water that fire fighters can manually discharge through hoses onto a fire. Water is fed into a piping system. The piping runs vertically (up and down) and horizontally (side to side) throughout the building. The piping running vertically is usually called risers. The risers are usually located in the staircase enclosures or in the hallways in the building. This piping system supplies water to every floor in the building. When a standpipe system is installed and properly maintained it is a very effective means for extinguishing fires. A typical standpipe system is shown below in the illustration below:

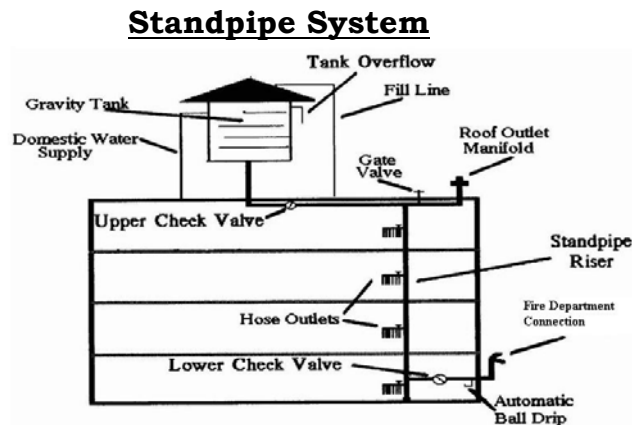

7.2 Classes of Standpipes Systems

Standpipe systems are classified depending on who is expected to use the system. The three classes are briefly described on the following:

Class I: This system is designed to be used by professional fire fighters. For example, the system is used by Fire Department and Fire Brigade personnel. The fire hoses in these systems are 2 1/2 inches in diameter. The large hose diameter makes it difficult to control the stream of water from the hose.

Class II: This system is designed to be used by the occupants of a building. The hose and nozzle are connected to the standpipe. They are ready to be used by occupants in case of a fire. The hose is 1 1/2 inches in diameter. The hose stream is easier to control than the Class I hose.

Class III: This system may be used by either professional fire fighters or by occupants of the building. The hosing may be adjusted to either 1 1/2 or 2 1/2 inches in diameter. This is done by attaching special reducing valves to the hose line.

7.3 Wet Standpipe System

This system always has water in the piping. The water in the system is always under pressure. In some cases a fire pump may be used to increase the water pressure. The wet standpipe system is the most commonly used standpipe system. It is used in heated buildings where there is no danger of the water in the piping freezing. Any part of the standpipe system that is exposed to freezing temperatures should be insulated. It is very important that the water in the piping does not freeze. Frozen water may prevent the standpipe system from working.

7.4 Dry Standpipe with an Automatic Dry Pipe Valve (Manual Standpipe)

This system is usually supplied by a public water main. Under normal conditions there is no water in the piping. Instead, there is air under pressure in the piping. A dry pipe valve is installed to prevent water from entering the standpipe system. The dry pipe valve is designed to open when there is drop of air pressure in the standpipe. When a hose is opened it causes a drop in air pressure in the standpipe system. Then the dry pipe valve automatically lets water flow into the standpipe. A control valve is installed at the automatic water supply connection. This valve should be kept open at all times to supply the standpipe system. This system is usually installed in a building that is not heated. Most dry pipe valves are designed so that a moderate air pressure in a dry pipe system will hold back a much greater water pressure. A drop of pressure in the piping will cause the clapper to open. The valve is said to have tripped.

Quick opening devices are used to reduce the time needed to open the clapper and allow water into the system. These devices are an accelerator and an exhaustor. They are both

automatically activated when a drop of 2 psi in air pressure is detected in the system. They quickly change the water and air pressure balance in the system. This change trips the dry pipe valve allowing the water to force its way through the sprinkler piping in less time. The failure of an accelerator or exhauster to operate will increase the normal tripping of a dry pipe valve.

7.5 Dry Standpipe with a Manual Control Valve

This system is supplied by a public water main. Under normal conditions this system has no water in the piping. The water is not allowed into the standpipe until a control valve is manually operated. The control valve remains closed until a fire occurs. The air in the piping is not under pressure. A pre-action valve prevents the water from entering the system. The valve is automatically opened when a fire detection system discovers that there is a fire. This system is usually used in a building that is not heated.

7.6 Dry Standpipe with No Permanent Water Supply (Manual Standpipe)

Under normal conditions this system has no water in the piping. Water is pumped into the standpipe system by the Fire Department. The water is pumped in through the Fire Department connection. This system cannot be used unless water is supplied by the Fire Department. A sign must be attached to each of the hose outlets. It should read "Dry Standpipe for Fire Department Use Only". This system is usually used in a building that is not heated such as unoccupied buildings and parking garage structures. Special care must be taken when using a dry standpipe system. The nozzle must never be pointed at the fire until all of the air has been drained from the system. Otherwise, pressurized air would be discharged onto the fire. This would cause the fire to burn more intensely.

Quick Opening Devices - In a dry pipe system there is a delay between the opening of a sprinkler head or a standpipe nozzle and the discharge of water. This delay may allow the fire to spread and more sprinkler heads to open. The delay is due to the time required for the air to leave the system's piping. This difficulty may be partly overcome by the installation of quick opening devices.

7.7 Yard Systems

A yard hydrant system is most often used in large private manufacturing plants or storage buildings. The yard system is often needed because the public water supply does not meet the needs of the fire protection system. The yard system usually has several private water sources supplying the total fire protection system. The total system may have a sprinkler system, hydrants, and a standpipe and hose system installed.

The water supply sources are all connected together in the yard system. This allows the water to be directly supplied to any part of the system when needed. Water can be supplied even when one of the supply sources is not working. The combined sources of

water keep the water pressure in the system at a high level. The picture below shows a detailed yard fire protection system.

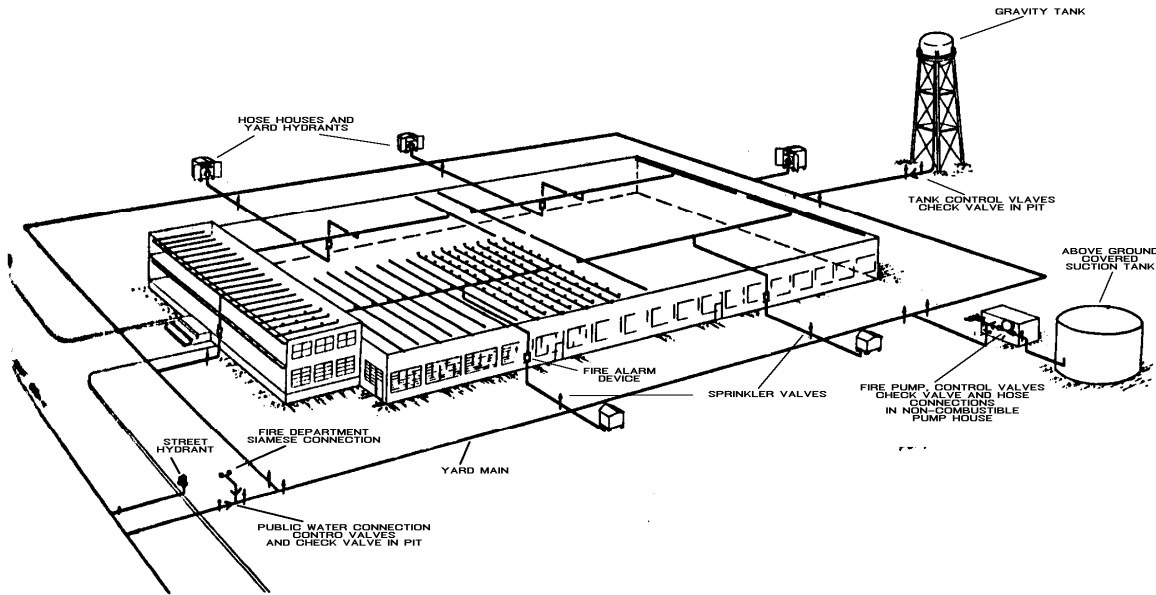

A Typical Yard Fire Protection System

Public Waterworks Connection - The street main supplies water using the water pressure in the public water works system. Sometimes a street main may not be connected to the system if it is located too far away from the building.

Pressure Tank - This tank may supply water to the yard system under pressure. The tank is filled with water and air. The air forces the water out under pressure when part of the fire protection system is activated.

The water supply sources are all connected to a main water supply grid. This supply grid surrounds the entire building. Control valves are installed at various locations on the system. These valves are called post indicator valves (PIV). As the name suggests they indicate the position of the valve. The valves are manually operated. Each valve has two positions, opened and closed. Under normal conditions the PIV valves are sealed open. The PIV valves allow the Fire Department to shut down only part of the system. The PIV valves are also used to shut down parts of the system when conducting repairs and maintenance. A typical PIV valve is shown on the following page.

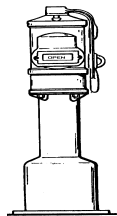

Typical PIV Valve

The water in the yard system is not allowed to flow into the public water system. It is prevented from doing so by a check valve.

Several supervisory and alarm devices are usually installed in the yard system. They indicate when there is a problem with the equipment. They also indicate when water flows through the yard system. These devices are needed to make sure that the system will work properly in case of a fire. The supervisory devices may be connected to a central station company. The central station company is automatically notified when there is any problem with the yard system. It will then notify the local fire house. When Post Indicator Valves (PIV) is installed in yard systems they should be painted red.

Hydrants may be installed in some systems. They allow the fire department to run hoses from the public water mains. The location of the hydrants will depend on the layout of the public water supply system.

7.8 Combination / Combined Systems

It is not uncommon to find occupancies having a combination of systems for fire protection. Examples of combination systems are:

- a. Combination System (Wet standpipe and Dry standpipe)
- b. Combined System (Wet standpipe system and Automatic Sprinkler System) - A standpipe system having piping that supplies both hose connections and automatic sprinklers. Each connection from a standpipe that is part of a combined system to a sprinkler system shall have an individual control valve and check valve of the same size as the connection.

PART 8: STANDPIPE SYSTEM COMPONENTS

8.1 Roof Manifold

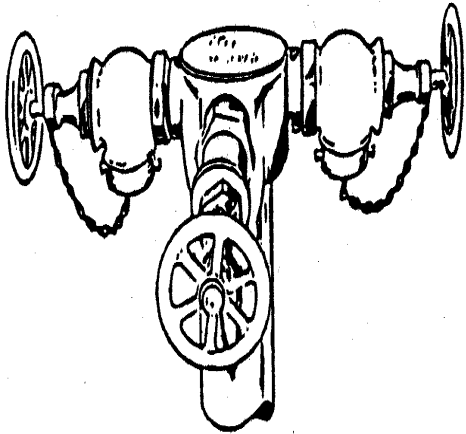

Roof Manifold

Standpipe systems are used in buildings where it may be difficult for the Fire Department to pump water on the fire. For example, standpipe systems are required in buildings that are over six stories 75 feet in height. A standpipe system may be combined with an automatic fire protection system. For example, a standpipe system and a sprinkler system may be installed in the same building. The standpipe and the sprinkler systems may even share the same water supply and riser piping. The top of the standpipe riser extends up onto the roof. Three hose connections are attached to the top of the standpipe riser. These three connections make up the roof manifold. The roof manifold is used when extinguishing fires on the roof or adjacent buildings. It is also used when testing the water flow in the standpipe.

At the top of the highest riser there shall be provided, above the main roof level, a three way manifold equipped with three 2 1/2 in. hose valves with hose valve caps. The manifold may be set in a horizontal or vertical position, provided the hose outlets are set back between 18 in. and 60 in. above the roof level.

8.2 Fire Department Connection

For **automatic standpipe systems**, a connection through which the fire department can pump supplemental water into the sprinkler system, standpipe or other system furnishing water for the fire extinguishment to supplement existing water supplies.

For **manual standpipe systems**, a connection through which the fire department can pump the primary water supply to the manual standpipe system at the required system demand.

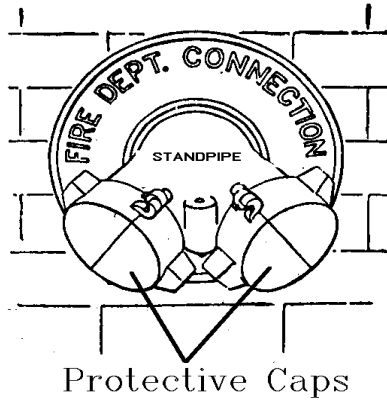

Fire Department Connections

Fire Department Connection - A Fire Department connection is always installed on the system. The connection is used by the fire department to pump water into the system. Fire Department connections must always be accessible. Each connection shall be equipped with a check valve. An auxiliary source of water supply for standpipe systems includes manually activated fire pumps or Fire Department connections.

A pressure restricting device shall be installed at each hose outlet where the static pressure exceeds 80 psi. An occupant of the building may be injured if a hose is used when the pressure restricting device is not installed. The pressure reducing device may be adjusted or removed by Fire Department personnel during an emergency.

Standpipe valve with cap and chain



In some occupancy's, only a Hose Valve is installed in lieu of both a hose valve and hose. The Fire Department attaches its own hose to this connection when fighting a fire.

Fire Department Connection to a Standpipe Riser

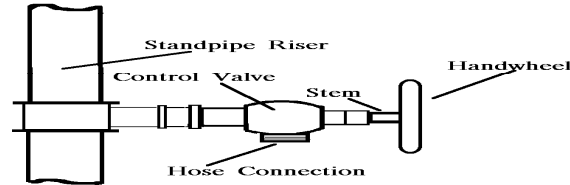

Each standpipe system may also be fitted with a drain valve. The drain valve is located at the lowest point on the standpipe system. The drain valve is used when the standpipe system has been used, tested, or repaired.

The automatic ball drip device between the check valve and the outside hose coupling on the Fire Department connection prevents water from building up in the piping. An automatic ball drip on a standpipe Fire Department connection that leaks under normal conditions is an indication that the check valve is defective. This drip device makes sure that Fire Department connection is not blocked by water which has frozen in the piping. If water freezes in the piping, the Fire Department will not be able to pump water into the system. They shall be installed in the horizontal position. They ensure that the Fire Department connection is not blocked by frozen water in the pipe. They are found between lower check valve and the Fire Department connection. Under normal conditions the piping between the Fire Department connection and the lower check valve should be dry.

8.3 Alarms and Supervisory Signal Devices

Supervisory devices are often connected to a central station company which monitors the sprinkler/standpipe system for problems with equipment and when standpipe hoses have been activated. In order to reduce the number of unwarranted alarms it is important that the central monitoring station is notified when any of the control valves are closed for maintenance or repair of the sprinkler system.

Standpipe systems are designed with built-in alarm devices. The most appropriate course of action to take when one of these devices activated is to respond to the fire alarm panel.

Devices and Equipment Supervised

Standpipe system supervision is commonly provided for (1) water supply control valves; (2) low water level in water supply tanks; (3) low temperature in water supply tanks or ground level reservoirs; (4) high or low water level in pressure tanks; (5) high or low air pressure in pressure tanks; (6) high or low air pressure in dry pipe sprinkler systems; (7) failure of electric power supply to fire pumps; (8) automatic operation of electric fire pumps, and (9)

fire detection devices used in conjunction with deluge and/or pre action and recycling systems.

Water flow Alarms

Water flow alarms and fire alarms give warning of the actual occurrence of a fire or other conditions such as broken piping. Alarms alert occupants and summon the Fire Department. Any signal, whether water flow or supervisory, may be used to give an audible local alarm. It may also send a signal to a central station company. The central station company will then contact the Fire Department.

Water operated alarm devices must be located near the alarm valve, dry pipe valve, or other water control valves in order to avoid long runs of connecting pipe.

Pressure Tank Alarms

All pressure tanks used to provide the required primary water supply of a sprinkler system should be equipped with a high and low air pressure, and a high and low water level electrical alarm system. This alarm system automatically controls the air-to-water ratio which should always be 1 to 2. However, when the water level or the air pressure falls below acceptable levels, an alarm signals to the C of F holder that there is a problem with the pressure tank.

Alarm Retarding Devices: An alarm check valve that is exposed to changing water supply pressure needs an alarm-retarding device. This is required to prevent unwarranted alarms when the check valve clapper is lifted from its seat by a temporary pressure surge.

8.4 Different type of Valves

8.4.1 Check Valves

A check valve is used to prevent water from flowing in the opposite direction. A check valve is a type of valve which only permits flow in one direction. These valves are often designed for safety reasons; to prevent backflow and to ensure that someone operating a system knows which direction water is flowing in.



Check valve

8.4.2 Swing Check Valves

The valve allows full, unobstructed flow and automatically closes as pressure decreases. These valves are fully closed when the flow reaches zero and prevent back flow. A swing

check valve is normally used in systems using a gate valve because of the low pressure drop across the valve.

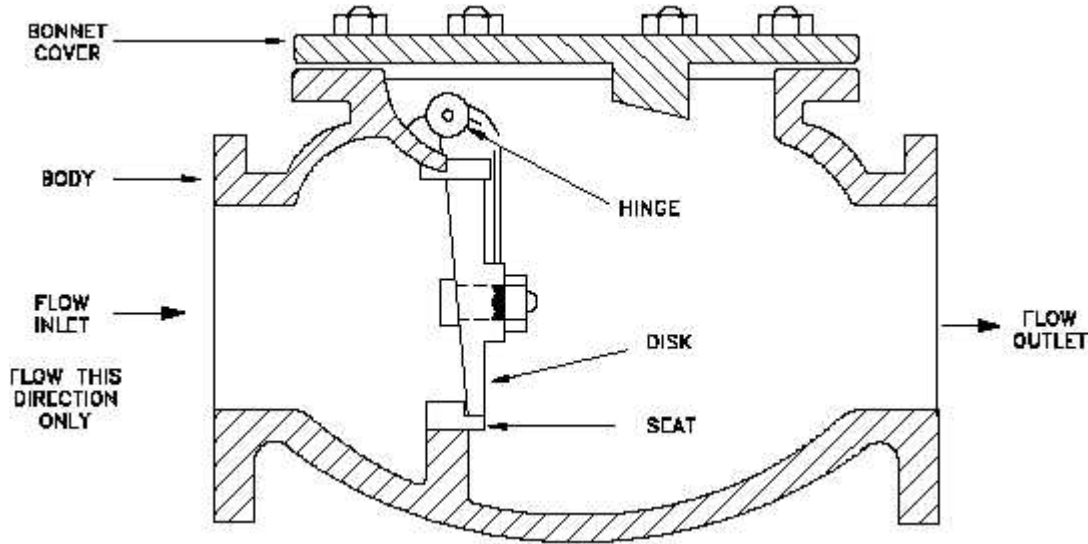

8.4.3 Alarm check Valves

The basic design of most alarm check valves is that of a check valve which lifts from its seat when water flows into a standpipe system. These alarm attachments are designed to initiate an alarm by a drop in water pressure in the standpipe system. The alarm signals the occupants of the building that the standpipe/sprinkler system has been activated.

8.4.4 Gate Valves (Non-Rising Stem)

Gate valves of the non-indicating type are provided in water distribution systems to allow for segments of the standpipe system to be shut off for repairs or maintenance without reducing protection over a wide area. Such valves are normally a non-rising stem type, which requires a special key wrench to operate. A valve box is located over the valve to keep dirt from the valve and to provide a convenient access point for the valve wrench to the valve nut. A complete record should be made for each valve in the system, including date of installation make, direction of opening, number of turns to open, any maintenance performed.

8.5.2 OS & Y (Outside Screw and Yoke)

OS&Y (Outside Screw and Yoke) gate valves are installed at several places in the system. The OS&Y valves are found just inside the building wall on the main riser, or outside in protected pits. The OS&Y valves can be used to shut down just a part of the standpipe system. Sections may be shut down when fighting a fire. Sections are also shut down for testing, repairs or maintenance. It is easy to tell if the OS&Y valve is in the open or closed position. If the stem is raised (OUT) above the control wheel the valve is open. If the stem is flush (IN) with the control wheel the valve is closed. A typical OS&Y gate valve is shown below. The valve in the picture is open.

O S & Y valve

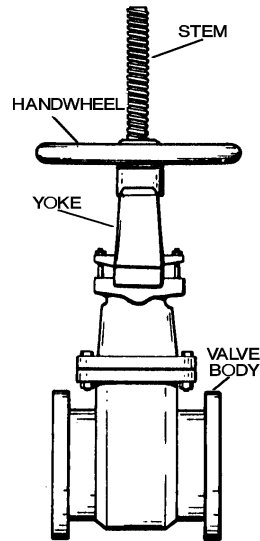

8.5 Fire Hose including Couplings and Nozzles

The care, use and service testing of these components must comply with the standard of NFPA 25, 2002 edition and NFPA 1962, 1998 edition in order to provide safety for users that the component will perform as required.

8.5.1 Fire Hose Outlet and Release Rack

At selected locations in the building the piping is connected to a hose. These connections are controlled by hose valves. No water is allowed into the hose until the valve is opened. The hose valve must be manually opened by the fire fighter. The hose is usually stored on a quick release rack. The hose at each outlet shall be kept upon a hose rack firmly supported and placed between 5 ft. and 6 ft. above the floor or landing. Hose valve shall not be operated for normal testing and maintenance procedure.

A Typical Fire Hose Outlet and Release Rack From year 1938-1968

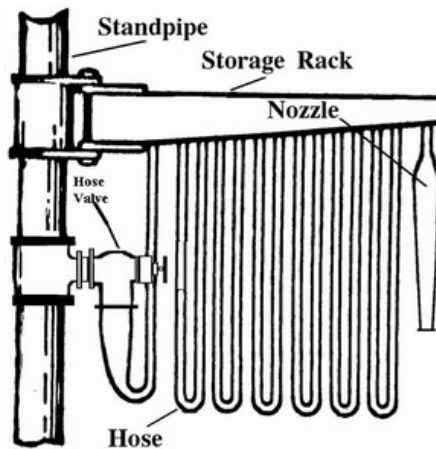
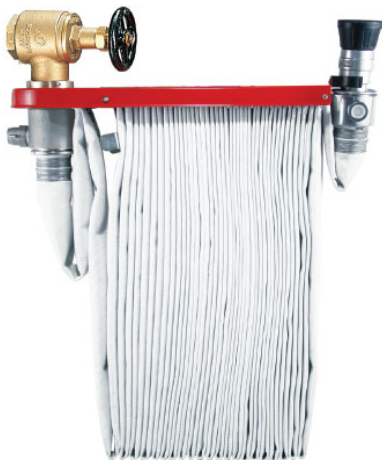

Inclined hose racks are often used, as most existing stations can accommodate such racks. The racks should be located where the sun or excessive heat will not damage the hose. The rack has the advantage of allowing the hose to drain internally while providing a drying area from which fire fighters can easily load and unload hose.

8.5.2 Hose Cabinets and Storage

Cabinet equipment identification - Cabinets shall be identified in an approved manner by a permanently attached sign with white letters not less than 2 inches (51 mm) high and a red background color, indicating the equipment contained therein.

Hose Cabinet



Exception: Doors that have either an approved visual identification clear glass panel or a complete glass door panel are not required to be marked.

Locking of cabinets shall be permitted in Institutional Group-3. Cabinets containing fire-fighting equipment such as standpipes, fire hoses, fire extinguishers or Fire Department valves shall not be blocked from use or obscured from view. Hose valves are capped with a hose valve cap fastened to the valve with a chain.

Storage - Hose in storage shall be kept out of direct sunlight and in well-ventilated location. Hose shall be stored only after it has been properly inspected, service-tested if required, cleaned, dried and rolled. Hose that is out of service for repair shall be properly tagged and kept separated from any hose that is in storage and ready for service.

To maximize life of hose, it should be stored in a ventilated area at temperatures between 32°F and 100°F (0°C and 38°C).

Hose Houses - Hose houses may be installed on the system. The hose house must be painted red. The house is usually located outside the main water supply grid. The house must be accessible at all times. Hoses, nozzles and other fire protection tools are kept in the hose house. Standpipe connections are located in the hose house. These connections allow the fire fighters to connect directly into the yard system. They are very helpful when the street mains are located too far away from the building. The connections save a lot of time when fighting a fire. Hose outlet valves are painted red.

8.5.3 Nozzles

Discharge Device. A device designed to discharge water in a predetermined, fixed, or adjustable pattern. Examples include, but are not limited to, spray nozzles, and hose nozzles. Nozzles on 2 1/2 in. hose, except for yard hydrants, shall be at least 15 in. in length, and shall have a smooth bore with a 1 in. or 1 1/8 in. discharge orifice.

A nozzle is attached at the end of the hose. The nozzle is used to direct the stream of water from the hose. An example of a typical nozzle is shown in the picture below:



A Hose Nozzle

Nozzles at auxiliary hose stations shall be Fire Department approved adjustable combination fog nozzles.

The hose and nozzle must be easy to reach at all times. The hose outlets are located so that every part of the building may be reached with a hose stream. The maximum length of a single hose line is 125 feet. Sometimes the hoses are installed in cabinets. If the hoses are installed in cabinets each cabinet should be labeled "FIRE HOSE". When the hose outlets are not easy to see, signs should be posted telling where the hose outlets are located. Nozzle valves attached to in-service hose shall be kept in the closed position.

8.5.4 Hose Records (Occupant-Use Hose)

Accurate hose records shall be maintained. Records are essential and necessary data to determine hose performance and ensure safe use in fire fighting. Cost effectiveness can also be determined.

Each length of hose shall be assigned an identification number for use in recording its history throughout its service life. The identification number shall be stenciled on the jacket or cover using an ink or paint that is not harmful to the hose. The identification number shall be permitted to be stamped on the bowl or swivel of the female coupling in a manner that prevents damage to the coupling. Where hose repairs are frequent, however, couplings and hose lengths can become intermingled so that either stenciling the hose or changing the couplings should be employed. In stamping couplings, the proper procedure is to insert a special steel plug with round edges into end of the expansion ring. One sharp blow from a steel numbering die will then clearly stamp the coupling. Coupling bowls can be damaged by improper stamping. Aluminum couplings should be stamped before they are hard coated. Some fire departments color code couplings as well as various tools to identify the company to which the equipment is assigned. This enables each company to readily identify and pick up its hose and equipment at a fire. Where mutual aid operations are frequent, each length of hose should be appropriately stenciled or marked with the identification the fire department owning same. A water-based latex

paint is not harmful to hose. Paints with a petroleum solvent base can cause the bond between the liner and jacket to fail.

Records of hose used by the fire departments shall be kept as part of the departments complete equipment inventory. Also conditions, repairs, changes and problems shall be recorded immediately for each length of hose.

Hose Record Card

Size (dia.) _____	Length _____	Type Hose _____	Date in service _____
Date Mfg _____		Type of Couplings: <u>Female/Male</u>	
=====Repairs=====			
Date	Condition	New Length	ID no.
_____	_____	_____	_____
_____	_____	_____	_____
_____	_____	_____	_____
_____	_____	_____	_____
_____	_____	_____	_____
Remarks: _____			

Test Record

Service test to _____ psi							
<u>Date</u>	<u>Service Test press res. Psi</u>	<u>Test OK</u>	<u>Reason Failed</u>	<u>Date</u>	<u>Service test pres. psi</u>	<u>Test OK</u>	<u>Reason Failed</u>
<u>Date</u>	<u>Exposed to possible damage</u>				<u>Date</u>	<u>Reason</u>	
		Removed from service					
		Condemned					
		Sold					
		Wrnty. failure					

Records for hose on racks or reels or in enclosures shall be kept at the hose location or at a control location on the premises where the hose is located.

The following information shall be included for each of hose:

- a. Assigned Identification number
- b. Manufacturer and part number
- c. Vendor
- d. Size (internal diameter of waterway)
- e. Length
- f. Type of hose
- g. Construction
- h. Date received and date put in service
- i. the date of each service test and the service test pressure
- j. Repairs and new length if shortened
- k. actual damage
- l. Exposure to possible damage
- m. Reason removed from service
- n. Reason condemned
- o. Indication that the hose has been removed from service or condemned with the warranty period because of an in-warranty failure.

Other information recorded might include coupling threads, manufacturer of coupling and part number, length of guarantee, label number, and cost.

Out-of-service hose shall be properly tagged with reason for removal from service noted on the tag.

8.5.5 Occupant-Use Hose

Occupant-Use shall be service-tested within 90 days prior to being put in service. Service testing of hose is to ensure its suitability for continued use. For unlined standpipe with trade size (1 ½ in – 2 ½ in) single jacket hose the acceptable service test pressure is 150 psi.

PART 9: WATER SUPPLY

Standpipe systems may be supplied from one or a combination of sources. For example, they may be supplied by public mains, gravity tanks, pressure tanks, reservoirs, rivers, or lakes. A single water supply would appear to be all that is needed to supply a standpipe fire protection system. This assumes that there is enough water at an acceptable pressure. However, there are a few reasons why it is good to have a second water supply source. These reasons include, but are not limited to:

1. A single supply source may be out of service (for maintenance or repair) during a fire emergency;
2. A single supply source may be disabled during a fire, or before the fire is fully extinguished;
3. The water supply source may fall below normal pressure or volume during an emergency.

9.1 Pressure Tanks

Pressure tanks are enclosed water tanks of limited size. Air pressure in the tank permits forceful discharge of water in the tank into the standpipe system. A pressure tank may be used as a primary or secondary water supply for a standpipe system. A pressure tank is usually housed in an enclosed structure. The temperature in the enclosure is kept at 40° Fahrenheit or above. The heated structure may be located anywhere in the building or even outside the building. Pressure tanks are usually kept approximately two-thirds full of water and one-third full of pressurized air. The acceptable air pressure inside the tank may vary from 15 psi to 80 psi, as per Department of Buildings (DOB) rules and regulations. The air compressor shall be provided with automatic controls for maintaining the air pressure. The capacity of the compressor shall be sufficient to build up the tank pressure to 75 psig within 3 hours or less. Pressure tanks shall be provided with approved closed circuit high and low water and high low air alarms. Pressure tanks shall be located at or above the top level of sprinklers.

The air pressure in the tank is automatically maintained by an air compressor. The maximum capacity of pressure tanks is typically 9,000 gallons. Some standpipe systems require more than 9,000 gallons of water. If necessary several pressure tanks can be used in combination to supply the system. A sectional view of a standard pressure tank is shown in the diagram below:

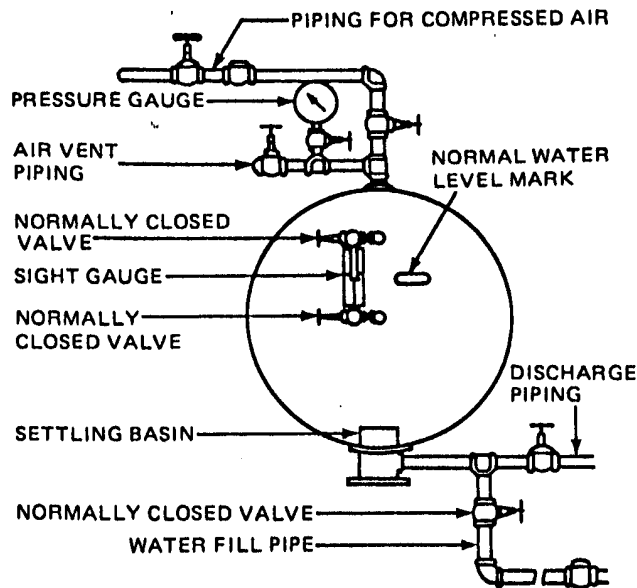

A Standard Pressure Tank

Pressure Tank Alarms

All pressure tanks used to provide the required primary water supply of a standpipe system should be equipped with two high and low alarm systems. One system monitors the high and low air pressure. The other system monitors the high and low water levels. The alarm system automatically monitors the air-to-water ratio which should always be 1/3rd (air) to 2/3rd (water). An alarm (high-low) or supervisory signals will annunciate when the water level or the air pressure falls too low. When this happens the pressure tank shall be adjusted or repaired immediately.

Supervision of the Pressure Tank

The pressure tank may also be supervised by an approved central station company, which monitors the standpipe system. Supervisory devices alert the central station company when there is a problem with the tank's water level, air pressure, or water temperature. These devices also alert the central station company when water has been discharged from the tank. When water has been discharged through a hose outlet or a sprinkler head the FDNY Borough Dispatcher shall be notified.

The central station company notifies the building owner when an alarm or supervisory signal is transmitted. It is required that the pressure tank is returned to good working order immediately.

The water gauge valve must be opened to examine the water level as shown in the sectional diagram below.

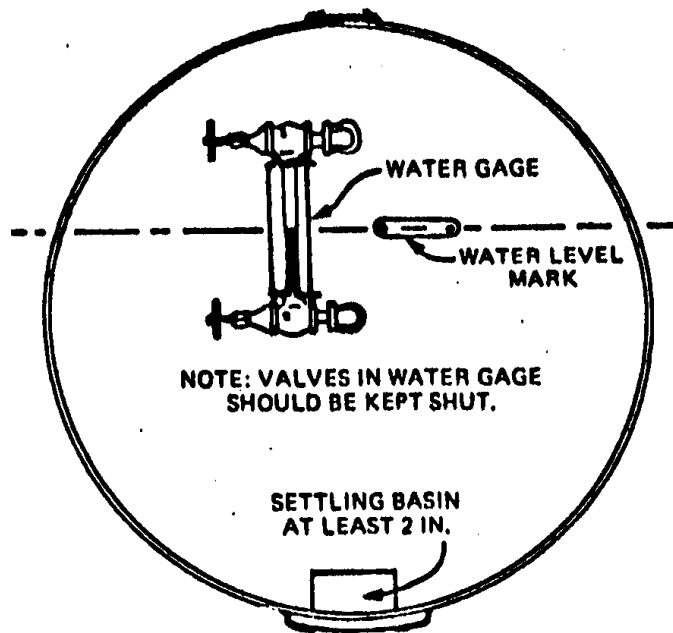

When the valve is opened the water will flow into the gauge. This allows the C of F holder to compare the water level in the tank to the desired water level mark. Adjustments to the water level shall be made as needed by an authorized individual. After visually inspecting the water gauge valve, the valve shall be closed. When the valve is closed, the water and air in the tank are isolated from the sight glass. If the gauge glass breaks the volume of water and the air pressure are not affected.

The inside of pressure tanks shall be inspected every three years. The inside of the tank shall be maintained free of rust and foreign materials.

The temperature inside the structure that houses the pressure tank shall be maintained during cold weather to ensure that the temperature is at a minimum of 40° Fahrenheit at all times.

9.2 Gravity Tanks

Gravity tank – The gravity tank supplies water using the force of gravity. Gravity tanks are used for water storage. They are made of wood, steel or concrete. Gravity tanks are used as a primary or secondary water supply source for standpipe systems. A gravity tank delivers water to the standpipe system without the use of pumping equipment. A gravity tank shall be at least 25 feet above the highest standpipe hose outlet that it supplies. Tanks may be located on the tops of buildings or raised on tall supporting towers. A gravity feed standpipe system distributes water throughout the fire protection piping without the use of pumping equipment.

An example of a typical gravity tank

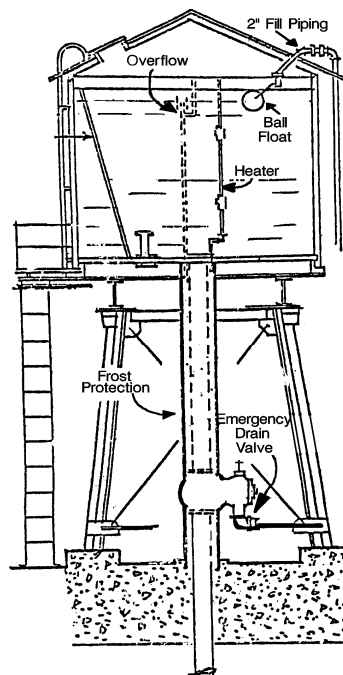

The water pressure in a gravity tank system depends on the elevation of the tank. This is a major advantage over other kinds of systems. For every 1 foot the tank is above the discharge outlet, an additional 0.433 psi of water pressure is achieved. For example a tank elevated at 100 ft above the discharge outlet will produce a pressure of 43.3 psi.

Automatic fill pumps supply the water to most gravity tanks. The pumps shall fill the tank at a rate of a minimum of 65 gpm (gallons per minute). Two floats control the amount of water in the tank. The floats turn on the fill pump when the water in the tank is too low. The floats shut off the pump when the desired water level is reached. The floats make sure the gravity tank always has the right amount of water to supply the standpipe system. All gravity tanks have an overflow pipe that drains off too much water in the tank. This happens if the floats do not turn off the fill pump. A fill pump is not necessary if the water pressure in the city water main is able to keep the tank filled with the right amount of water.

Gravity tanks are exposed to very low temperatures. All parts of the gravity tank must be insulated or heated to keep the water from freezing. Several methods are used to heat the tank and the pipe that supplies the water. (1) Hot water is circulated by gravity. (2) Steam is discharged directly into tank. (3) Steam coils are placed inside the tanks. (4) Heat from the sun is used. The C of F holder can find out the temperature of the water by looking at a thermometer. The thermometer is located near the heating device. The tank can be severely damaged if the water inside the tank freezes. The temperature of the water should always be at least 40° Fahrenheit. Ice should not be allowed to build up on the gravity tank. The extra weight of the ice can weaken the supports of the tank, and cause the tank to collapse. Falling icicles may also cause damage or injury. It is essential to be sure that the tank is properly heated, insulated, and carefully maintained.

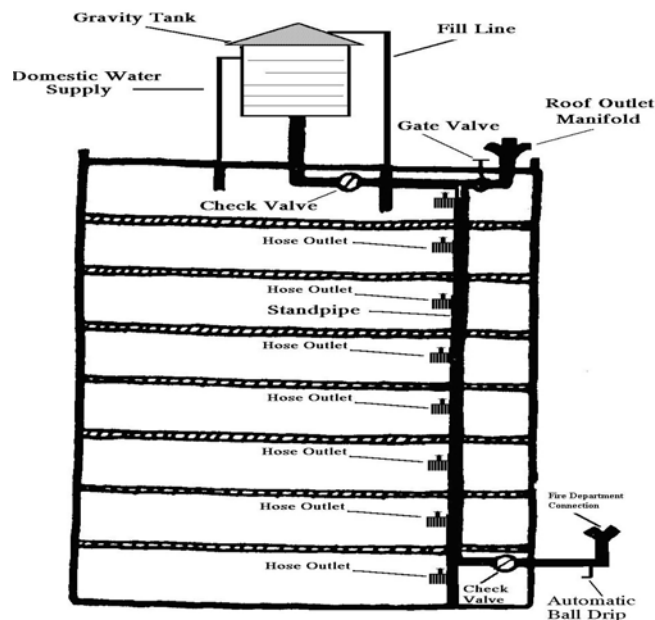

Wet Standpipe System

The gravity tank shall always have a full supply of water. A full tank of water is needed to be sure the standpipe system works properly during a fire. Keeping the tank full of water also prevents wooden tanks from shrinking. A full tank of water also helps to keep steel tanks from rusting.

It is best if gravity tanks are used only for fire protection and for no other purpose. Tanks used for other purposes need to be refilled more often. The tanks become settling basins for sediment mixed in with the water. This sediment is then drawn into the piping. This may cause the standpipe system to become clogged and not work properly. The Borough Dispatcher should always be notified when a tank cannot be used for any reason.

Failure of a standpipe system supplied by a gravity tank during a fire is usually caused by not enough water in the tank. The standpipe system cannot be supplied if there is not enough water in the tank. Too much water in the tank can also cause the fire protection system to fail. Too much water in the tank may cause damage due to the weight of the extra water. This could cause the gravity tank to collapse.

The gravity tank must be constantly monitored to be sure that the tank and its parts are working. Electrical supervision devices monitor the water temperature and the water level in the gravity tank. These devices send signals to a central station company about the water level and water temperature. The central station company notifies the C of F holder when a problem with the gravity tank is detected. The C of F holder should correct the problem as soon as possible. The supervisory devices are sometimes called high and low alarms since they also send audible signals to alert the C of F holder when there is a problem.

Combination Gravity Tank and Pressure Tank Installation

Pressure tanks may be used in combination with gravity tanks to supply a standpipe system. Both tanks may be used to make sure that an adequate water supply is available. The pressure tanks also provide added water pressure to the fire protection system. An example of a combined installation is shown on the picture below:

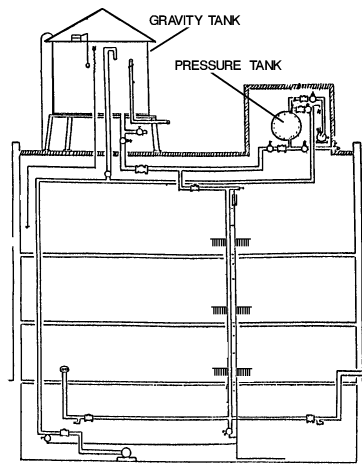

Combination Gravity Tank and Pressure Tank Installation

9.3 Fire Pumps

A fire pump can be used as a primary water supply source for a standpipe system. Fire Pump draws water from a suction tank and pumps it into the system when needed. They may also be used in combination with gravity tanks and pressure tanks that supply a standpipe system. Water tanks and the Fire Department connections may also be connected to the fire pump to supply water to a standpipe system. The fire pump is usually connected to the public water main for most of its water supply. Fire pumps are designed to take the water from a supply source and then discharge the water into the standpipe system under pressure. The pressure with which the water is discharged from the pump is called the ***total head***. The total head is usually measured in PSI. The higher the psi rating of the pump the greater the pressure with which the water can be discharged.

9.4 The Centrifugal Pump

The centrifugal fire pump is the standard pump used in most fire protection systems. This is the preferred pump because it is reliable, compact, and requires minimum maintenance. It can be powered by a variety of drivers including electric motors, internal combustion engines, and steam turbines.

Principles of Operation

The water available to the centrifugal pump shall always be under pressure since the fire pump cannot draw water by itself from the supply source. While most pumps are supplied by municipal water mains, suction tanks may also be used for pump supplies. These tanks must be able to provide sufficient pressure to the pump for normal operation. The water flows from the tank through the supply inlet into the pump. As the water flows through the center of the pump it pass a rotating impeller. The impeller flows the water through the inlet side of the pump. The impeller through discharges the water under increased pressure through the standpipe system.



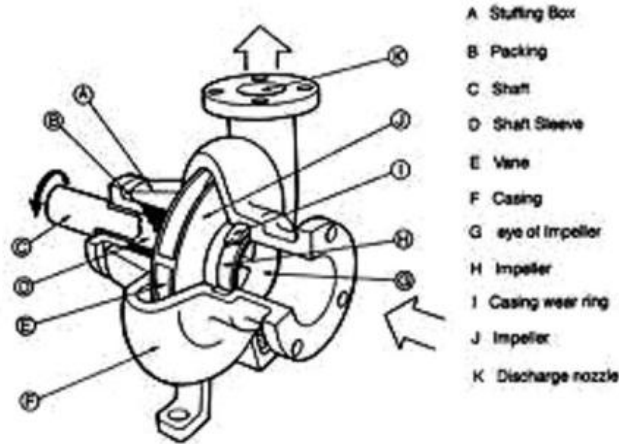

Impeller for HP 75-100 pumps

Centrifugal Fire Pumps are rated between 250 gpm (gallons per minute) up to 5000 gpm. Most centrifugal pumps have a single impeller and are therefore commonly a single stage fire pumps. A typical centrifugal pump is shown in the picture below.

A Typical Centrifugal Pump

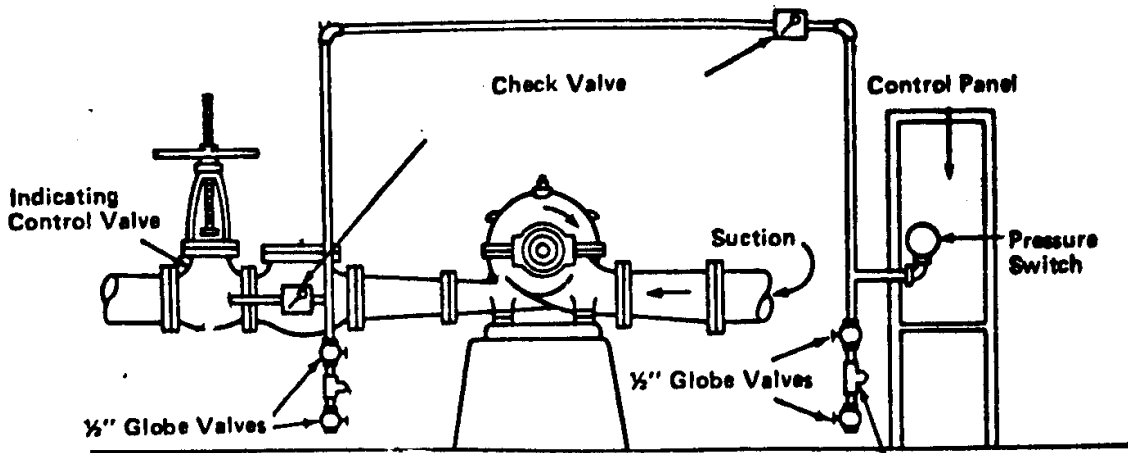

9.5 The Vertical Turbine Pump

The vertical turbine pump is designed as a modified centrifugal pump that can draw water from streams, ponds, wells etc. Unlike the standardized centrifugal pump. The vertical turbine pump does not required a suction supply to be under pressure for it to operate. Instead it draws the water into the pump through suction. When it reaches a rotating impeller, the water pressure is then increased and is forcefully discharged through the fire protection system.

Although the vertical turbine pump is capable of drawing water from a well, it is generally not recommended to use a well as the main source water supply source because it may dry up without warning. Should the well dry up it would make the fire pump useless. It is better to draw from the well and to fill a water storage tank. The fire pump should then be attached to the storage tank as it is a more reliable supply source.

It is important to inspect the water intake hose, foot valve, and the strainer regularly. Mud, gravel, leaves, any other materials can obstruct a system's piping and cause damage to the pump. A vertical fire pump arrangement using a water reservoir is shown on the following page.

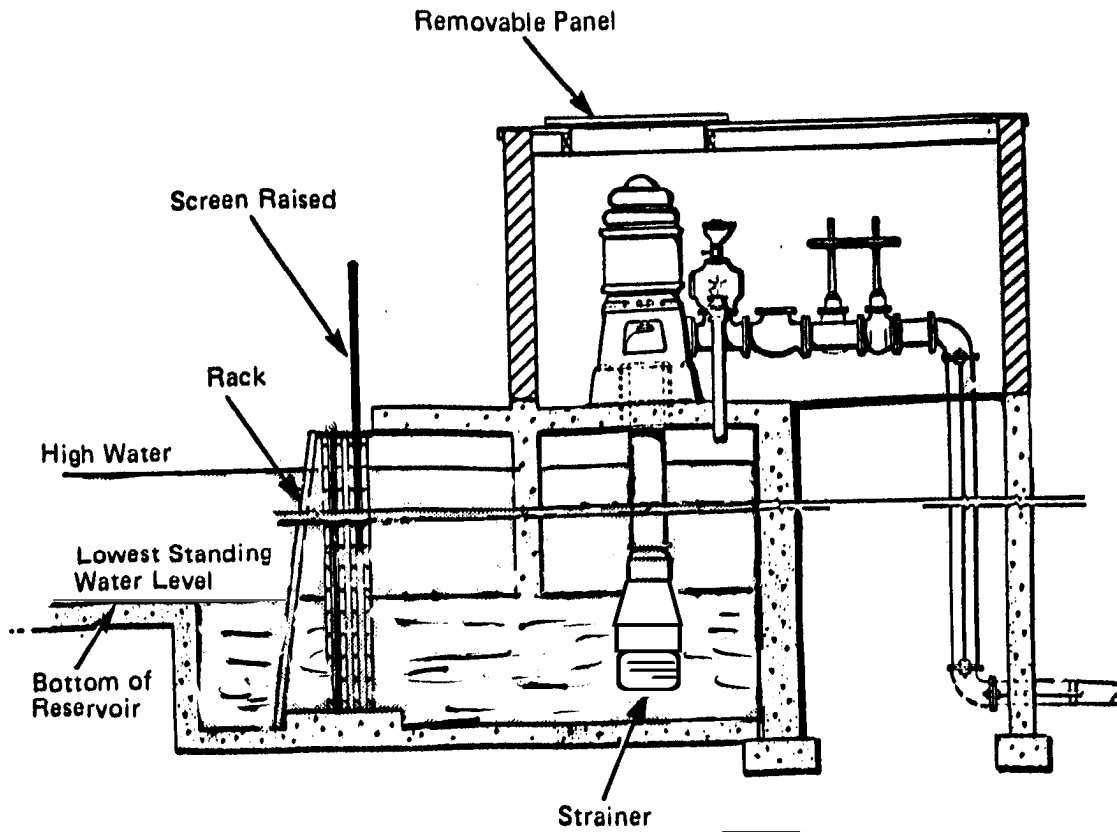

A Vertical Fire Pump Arrangement Using a Water Reservoir

Pump Activation

A fire pump can be started automatically or manually. The pump can be started automatically by an electric controller or an engine controller. Controllers activate the pump when there is a drop in water pressure or water flow within the fire protection system. The controllers are set so that a minor drop in water pressure or minor increase in water flow will not activate the pumps. The controllers for fire pumps are costly. They require extensive periodically inspection, testing and maintenance. If an electric motor

drive is used, then a standby power generator is required in some occupancies. If an engine controller is used the appropriate fuel storage tanks shall be filled and checked regularly.

When manually activated pumps are installed, they are used in combination with a gravity tank or a pressure tank. These tanks are designed to operate when there is a pressure drop within the fire protection system. The operation of the gravity or pressure tank and the triggering of its supervisory devices (alarms) alert the C of F holder that the fire pump must be activated. Manually operated fire pumps are often found in industrial and manufacturing occupancies having personnel on the premises at all times.

Often remote push buttons are used to activate the pump. These remote push buttons are designed to start the pump, but not to stop the pump. Pumps may be also designed with a timer installed that keeps the pump running for predetermined period of time once it is activated. This timer is designed to reduce the wear on the pump and its parts due to excessive starting and stopping.

Jockey Pumps

Jockey pumps are designed to automatically or manually operate when there is a slight drop in pressure due to the leakage within the system or a pressure surge. The jockey pump restores the pressure in the fire protection system to the required level. When the drop of pressure within the system is greater than the capacity of the jockey pump, the fire pump is activated.

Fire Pump Location

The fire pump should be housed in a room that is fire resistant or constructed of noncombustible material. The pump room should be located as close as possible to the fire protection system. The pump room should be kept clean and accessible at all times. The fire pump, driver, and controller should be protected against possible interruption of service. The temperature inside the pump room should be maintained above 40° Fahrenheit at all times to prevent freezing of the water in the system. The pump room should only be used for fire protection functions and not for general plant operations.

Operation and Supervision

When fire pumps are activated by electric automatic controllers it is essential that they are constantly monitored to ensure the availability of the electrical power supply in case of an emergency. For this reason, supervisory devices are installed on the pumps to alert the C of F holder and/or a central station company when there is an electrical power failure. In cases where the steam turbines or internal combustion engines are used similar supervisory devices are installed to signal when there is a problem with the controlling equipment.

PART 10: INSPECTION, TESTING AND MAINTENANCE

The standpipe system must be regularly inspected by the C of F holder. This is to make sure that the system is working properly at all times. This visual inspection should make sure that the system is free from corrosion. The inspection should also make sure that there is no physical damage to the system. Special attention should be paid to any evidence of tampering with the standpipe system. Any part of the system that is damaged or missing should be repaired or replaced immediately.

All valves and connections to the automatic water supply sources should be inspected. The valves should be checked to make sure that they are in the correct position. The valves should also be labeled to show their correct position and purpose. The hose outlets should be checked to make sure that the pressure restricting devices are present. The Fire Department should be notified when any part of the system is shut down for maintenance or repairs. A sign should be posted indicating that the section is shut down. All Fire Department connections must be tested at least once every 5 years.

All major defects in the system should be immediately reported to the local fire house, the owner of the building and the Bureau of Fire Prevention should also be notified. Major defects include: an empty tank, a break or a leak in the system's piping, an inoperative or shut water supply valve or a defective Fire Department connection. The defects should be corrected as soon as possible. A complete or partial shutdown of the standpipe system for repairs or any other reason must also be reported.

Minor defects should be reported to the owner of the building. The defects should be repaired within 30 days. If the defects are not corrected within 30 days, they must be reported to the Bureau of Fire Prevention.

The date of all inspections, maintenance and repairs made on the system must be recorded on the inspection record card. The record should also include the C of F number and the signature of the C of F holder. This record must be posted near the main control valve on the premises. All records must be kept for a period of at least three years. They should be made available to any representative of the Fire Department.

Standpipe system maintenance and inspections (FC 901.6)

1. Automatic and non-automatic standpipe systems shall be inspected, tested and maintained as required by NFPA #25 2002 edition by a competent person holding a C of F, employed by the owner, to see that all parts of the system are in good working order, and that the Fire Department connection or connections, if any, are ready for immediate use by the Fire Department. A detailed record shall be kept of each inspection for examination by any representative of the Fire Department.

2. At least once in five years, the Fire Department connection or connections, for a standpipe system shall be subjected to a hydrostatic pressure test. The standpipe system shall also be subjected to a flow and pressure test to demonstrate its suitability for Fire

Department use. The test shall be conducted by the owner's representative before a representative of the Fire Department.

3. There shall be one or more employees instructed in the maintenance of standpipe systems.

Inspection and Maintenance of the Gravity Tank

The gravity tank should be regularly inspected and maintained. Maintenance is needed to be sure that the tank functions correctly. For example, the tank may need to be painted regularly to prevent rusting. Before the inside of a gravity tank is repainted the surface should be thoroughly dried. All loose paint, rust, scale, and other surface contamination should be removed and local patching shall be performed where required. A complete finish coat of paint is needed when the paint has weathered thin. A new coat of paint also improves the appearance of the tank after it has been patched.

Painters must be careful that scrapings or other foreign materials do not fall down the outlet into the riser piping. The discharge outlet may be covered for protection during repairs. Only a few sheets of paper or a paper bag tied over the end of the settling basin stub should be used. The paper bag should be removed immediately after the job is finished.

Pump Inspection and Maintenance

In order to ensure the reliable operation of the pump in the case of an emergency regular inspections and maintenance should be conducted by the C of F holder. The pump should be activated each week according to the manufacturer's specifications to ensure that it is working properly. When the pump is in operation, a small water leak is desirable and should not be considered a malfunction.

If an automatic controller operates the fire pump, the pump should be activated by reducing the water pressure in the system. This can be done by opening the test drain or initiating a large water flow from the system. By starting the fire pump this way the C of F holder can determine if the automatic controller is working properly. Care should be taken to make sure that the pump does not overheat while conducting the test.

The centrifugal pump relies on the water supply for cooling and lubrication. The pump should never be operated without the pump being supplied with water.

A visual inspection of all parts of the pump and the controlling equipment should also be conducted. This inspection should include the condition and reliability of the power supply. If any problems are discovered with the equipment immediate action should be taken to correct them.

Fire pumps should be fully tested to make sure that the pump, driver, power supply and all other parts are working properly. Several different water supply sources may be used in a yard system.

Inspection and Maintenance of Yard Systems

The C of F holder should conduct regular inspections of the entire yard system. A record of all inspections should be made. The C of F of holder should sign and date all records. These records should be kept for at least 3 years. They should be made available to any representative of the Fire Department.

The C of F holder should make sure that the hose houses are in good working order. All equipment inside should be inspected. The hose house should be accessible at all times. The hose house should be painted red. Care should be taken to make sure that the area inside the house is kept clean and dry. All valves should be checked to make sure that they are in the correct position.

Any problems with the equipment in the yard system should be noted. Major defects should be reported to the Fire Department and the owner of the building immediately. Minor defects should be reported to the owner. In all cases, the defects in the system should be repaired immediately.

10.1 A Complete Summary of Tasks Of Inspection, Testing & Maintenance

I. INSPECTION

A. Standpipe Systems:

Gauges:

- On dry, pre-action and deluge systems shall be inspected **weekly** to ensure that normal air and water pressures is maintained;
- Where air pressure supervision is connected to a constantly attended location shall be inspected **monthly**;
- On wet pipe sprinkler system shall be inspected **monthly** to ensure good condition & that normal water supply pressure are being maintained.

Alarm Devices:

- Alarm devices shall be inspected **quarterly** to verify that they are free of physical damage.

Buildings:

- **Annually**, prior to freezing weather, buildings with wet pipe systems shall be inspected to verify that window, skylights, doors ventilators, other opening and closures, blind spaces, unused attics, stair towers, roof houses and low spaces under buildings do not expose water-filled standpipe piping to freezing and to verify that adequate heat with temperature is 40°F (4.4°C).

Hanger/Seismic Braces:

- Hangers installed in concealed space such as above suspended ceilings shall not need inspection;
- Hangers installed in areas that are inaccessible for safety considerations due to process operations shall be inspected during each scheduled shutdown.
- Hangers and braces shall be inspected **annually** from floor level to ensure they are

in place, properly aligned and otherwise not damaged. All defects and deficiencies shall be corrected.

Piping:

- Shall be inspected **quarterly** from the floor level to ensure there is no mechanical damage, leakage, corrosion, misalignment and that required supports and bracing are in place and are in good condition and not missing. Nothing shall be attached to any sprinkler system component.
- Pipe installed within concealed (such as above suspended ceilings spaces) are not required to be inspected. Exposed piping installed in areas that are inaccessible for safety considerations due to process operations shall be inspected during each scheduled shutdown.
- Pipe installed in areas that inaccessible shall be inspected during each scheduled shutdown;
- Piping, pipe support devices, control valves and supervisory devices are inspected for damage or missing .

Pressure Regulating devices

Hose Connections:

- All valves shall be inspected **quarterly** to ensure the hand wheel is not broken or missing, the outlet hose threads are not damaged and are without leaks. The pressure restricting device and the cap, if so equipped shall be in place Hose valves are not required to be operated.
- All valves shall be inspected **quarterly** to ensure hand wheel is not missing or broken and that there are no leaks.
Occupant hose shall be physically inspected annually to determine that it is free from debris, the hose exhibits no evidence of rot, mildew, or damage by vermin, or burns, cuts and abrasions, and any couplings and nozzle has not been vandalized.
- Manual, semiautomatic, or dry standpipe – valve does not operate smoothly
Hose must be removed from service and replaced with new hose or nozzle.
Hose shall be un-racked, unreeled, or unrolled annually.

Hose 1962

- Hose shall be inspected and services tested as specified NFPA 1962, within in 90 days prior to being placed in service for the first time and at least **annually** thereafter. Hose carried on fire apparatus shall be loaded in such a way that air can circulate under the hose load to eliminate or reduce the growth of mildew in the hose jacket and rust and corrosion
- Only clean, dry hose shall be placed into service.
- Hose shall be removed from the apparatus and reloaded so that the folds occur at different positions with sufficient frequency to prevent damage and the setting of permanent folds in the rubber lining.
- Large-diameter hose used to supply a pump from a hydrant shall be protected from chafing with chafing blocks or similar protection where it comes in contact with pavement or curbing.
- When connecting a pump to a hydrant, the hose shall be bent slightly to avoid kinks when the water is turned on.

- Care shall be taken to prevent the hose from chafing.
- Care shall be taken to avoid dragging large-diameter fire hose, but if the hose must be dragged, it shall be dragged when flat.
- Remove and inspect the hose , including gaskets, and re-rack or re-reel at intervals in accordance with NFPA 1962
- Hose shall be inspected for mildew, cuts abrasions, coupling damaged , gaskets missing or deteriorated, incompatible threads on coupling .
- Also shall be inspected that hose not connected to hose rack nipple or valve and outdated hose test.

Hose storage device or Rack

- Storage racks are commercially available, but many users have built their own to fit their particular needs.
- Storage device shall be inspected **annually** for damage, obstruction , difficult to operate, hose improperly racked or rolled, nozzle clip in place and nozzle correctly contained.
- If enclosed in cabinet and will hose rack swing out at least 90 degrees.

Cabinet

- Check overall condition **annually** for corroded or damaged parts, difficult to open or cabinet door will not open fully and door glazing cracked or broken.
- If cabinet is break-glass type, is lock functioning properly, break-glass device missing or not attached.
- Not properly identified as containing fire equipment visible obstructions and all valves, hose, nozzles fire extinguisher etc, easily accessible.

Tank Exterior:

- The **exterior** of the tank, supporting structure, vents, foundation, and catwalks or ladders shall be inspected **quarterly** for damages and weakening.
- The area surrounding the tank shall be inspected **quarterly** to ensure it is free of combustible storage, trash, debris, brush, or material that could present a fire exposure hazard.
- Any accumulation of material on or near parts that could result in accelerated corrosion or rot; ice build up; the exterior side and top of embankments supporting coated fabric tanks are free of erosion.

Pressure Reducing and Relief Valves:

Fire Pumps:

- **Casing relief valves** - all circulation relief valves shall be inspected **weekly** to verify that water flows through the valve when the fire pump is operating at shut- of pressure (i.e. churn) to prevent the pump from overheating.
- **Pressure relief valves** shall be inspected **weekly** to verify that the pressure downstream of the relief valve fittings in the fire pump discharge piping does not **exceed the pressure for which the system components are rated**

B. Fire Booster and Special Service Pumps:

Pump House, Heating Ventilating Louvers:

- The visual inspection shall be performed **weekly** to ensure heat is not less than

40°F (4.4°C) and 70°F (21°C) for pump room with diesel pumps without engine heaters.

- Ventilating louvers shall be free to operate.

Fire Pump:

- A **weekly** visual inspection shall be made to ensure the pump suction and discharge and bypass valves are fully open;
- All piping shall be free of leaks;
- Suction line pressure gauge readings shall be normal and reservoir is full;
- System line pressure gauge readings shall be normal;
- Wet pit suction screens shall be unobstructed and in place.
- Check **annually** the accuracy of pressure gauge and sensors, pump shaft endplay, coupling alignment and wet pit suction screen.

Diesel Engine Fire Pump System:

- **Fuel system** – Tank level shall be 2/3 full, the tank float switch shall be in auto position, solenoids valve operational, check for water in the fuel system and condition of flexible hoses connectors **weekly**.
- **Lubrication system** - Oil level in right angle gear drive is normal and ensure that lube oil heater is adequately lubricated **weekly**;
- **Cooling system** – Check level, adequate cooling water to heat exchanger, water pump, condition of flexible hoses and connections **weekly**; **annually** inspect duct work, clean louvers (combustion air)
- **Exhaust system** – check for any leakage, the drain condensate trap **weekly**; **Quarterly** check insulation and fire hazards;
- **Battery system** – Check electrolyte level of battery system along with the charger and charge rate **weekly**;
 - **Monthly** - Remove corrosion on pump casing, clean and dry housing;
 - **Quarterly** – Check that terminals clean and tight;
- **Electrical System**- A general inspection, such controller pilot light on, transfer switch is closed, reverse phase alarm pilot light is off or normal phase rotation pilot light is on oil level in vertical motor sight glass is normal **weekly**.
 - Check **monthly** circuit breakers or fuses;
 - Check **quarterly** for wire chafing where subject to movement.

C. Water Storage Tank:

Condition of water in tank:

Water Level:

- Tanks without supervised water level alarms constantly attended location shall be inspected **monthly**.
- Tanks with supervised water level alarms constantly attended location shall be inspected **quarterly**.

Air Pressure:

- Air pressure without supervised air pressure source shall be inspected **monthly**.
- Air pressure with supervised air pressure source shall be inspected **quarterly**.

Water Temperature:

- The temperature of water tanks shall not be less than 40°F (4°C).
- The temperature of water in the tanks **without** low temperature alarms connected to a constantly attended location shall be inspected and recorded **daily** during the heating season.
- The temperature of water in the tanks with low temperature alarms connected to a constantly attended location shall be inspected and recorded **weekly** during the heating season.

Heating System:

- The heating system and components including piping without a low temperature alarm shall be inspected **daily**.
- The heating system and components including piping with a low temperature alarm shall be inspected **weekly**.

Tank Exterior:

- The **exterior** of the tank, **supporting structure**, vents, foundation, and **catwalks or ladders** shall be inspected **quarterly** for damages and weakening.
- The **area surrounding** the tank shall be inspected **quarterly** to ensure it is free of combustible storage, trash, debris, brush, or material that could present a fire exposure hazard.
- Any accumulation of material on or near parts that could result in accelerated corrosion or rot; ice build up; the exterior side and top of embankments supporting coated fabric tanks are free of erosion.

Expansion Joints shall be inspected **annually** for leaks and cracks.

Hoops and Grillage of a wooden tank shall be inspected **annually**.

Exterior painted, coated or insulated surfaces of the tank and supporting structure, where provided shall be inspected **annually** for signs of degradation.

Interior Inspection- The interior of **steel tanks** without corrosion protection shall be inspected every **3 years**. The interior of all other types of tanks shall be inspected every **5 years**. The tank interior shall be inspected for signs of pitting, corrosion, spalling, rots other forms of deterioration waste materials and debris aquatic growth and local or general failure of interior coating.

D. Valve and Valve Component:

Deluge Valves:

- The valve **enclosure** without temperature alarm heating equipment is subject to freezing shall be inspected **daily** during cold weather for its ability to maintain a minimum temperature of at least 4°C (40°F);
- Valves **enclosures** equipped with **low temperature alarms** shall be inspected **Weekly** during cold weather.
- **Exterior valves** shall be externally inspected **monthly** to ensure it is free from physical damage, the valve seat is not leaking, all trim valves are in the appropriate open or closed position and electrical components are in service.
- **Interior** - the interior of the valve and the condition of detection devices shall be inspected **annually** when the trip test is conducted.
- **Internal inspection** of valves that can be reset without removal of a faceplate shall be permitted to be conducted every **5 years**.

- **Strainers, filters, restricted orifices** and diaphragm cambers shall be inspected internally every **5 years** unless test indicate a greater frequency is necessary

Dry Pipe Valves/ Quick Opening Devices:

- The valve **enclosure** heating equipment is subject to freezing shall be inspected **daily** during cold weather for its ability to maintain a minimum temperature of at least 4°F (40°C);
- Valves **enclosures** equipped with **low temperature alarms** shall be inspected **Weekly** during cold weather.
- **Exterior** dry pipe valves shall be externally inspected **monthly** to ensure they are free from physical damage, the intermediate chamber is not leaking, all trim valves are in the appropriate open or closed position and electrical components are in service.
- The **Interior** of the dry pipe valves shall be inspected **annually** when the trip test is conducted.
- **Strainers, filters, restricted orifices** and diaphragm chambers shall be inspected internally every **5 years** unless test indicate a greater frequency is necessary.

Backflow Prevention Assemblies:

- The double and single check assembly valves and double check detector assembly valve shall be inspected **weekly** to ensure that the OS&Y isolation valves are in the normal open position;
- Valves secured with locks or electrically supervised shall be inspected **monthly**.

Fire Department Connections:

- FD connection shall be inspected **quarterly** to verify the connections are visible and accessible, couplings or swivels are not damaged and rotate smoothly;
- Plugs or caps shall be in place and undamaged;
- Gaskets shall be in place and in good working conditions;
- Identification signs are in place (such as distance to the nearest fire hydrant);
- The check valve are fully operational and not leaking;
- The automatic drain valve shall be placed in the **horizontal** position and operating properly
- The clappers within FDC shall be in place and operating properly.

Control Valves:

- All indicating valves controlling water supplies shall be sealed, locked or provided with other approved methods as outlined in NFPA 25, 2002 edition. A seal is defined as an easily removable device (no key required) that will indicate the unauthorized operation of a valve.

Using this method shall require **weekly** inspections of each valve by the C of f holder. All indicating valves controlling water supplies equipped with locks and/or supervised shall be inspected **monthly**

- The inspection shall verify that, it is the normal open or closed position, properly sealed, locked, or supervised, provided with appropriate wrenches, free from external leaks and provided with appropriate identification.

Pressure Reducing and Relief Valves:

Fire Pumps:

- **Casing relief valves** – all circulation relief valves shall be inspected **weekly** to

verify that water flows through the valve when the fire pump is operating at shut-of pressure (i.e. churn) to prevent the pump from overheating.

- **Pressure relief valves** shall be inspected **weekly** to verify that the pressure down-stream of the relief valve fittings in the fire pump discharge piping does not exceed the pressure for which the system components are rated.

Alarm Valves:

- **Exterior** alarm valves shall be externally inspected **monthly** to ensure the gauges indicate normal supply water pressure is being maintained. The valve shall be free of physical damage and all valves are in the appropriate open or closed position. The retarding chamber or alarm drains shall be in a good condition without leaks.
- All **alarm valve** and their associated **strainers, filters, and restricted orifices** shall be inspected **internally** every **5 years** unless test indicate a greater frequency is necessary.

Check Valves -

- Shall be inspected **internally** every **5 years** to verify that all components operate correctly, move freely and are in good condition.

Standpipe Systems:

- All valves shall be inspected **quarterly** to verify the valve in the open position, not leaking in a good condition, with hand wheels installed and unbroken. Downstream pressures shall be maintained in accordance with the design criteria.

II. TEST

A. Standpipe Systems:

Alarm Devices – water flow alarm and supervisory devices shall be tested **quarterly** to verify that they are free of physical damage.

Water flow alarms on wet pipe systems shall be done by opening the inspector’s test connection. If a freezing weather conditions or other conditions disallow the use of the test connection, the bypass connection shall be permitted to test.

Gauges - Gauges shall be replaced every **5 yrs** or tested every 5 yrs by comparison with a calibrated gauge. Gauges that are not accurate within 3% of the full scale shall be recalibrated or replaced.

B. Fire Booster and Special Service Pumps:

Pump Operation:

- A **weekly** test of fire pump assemblies shall be conducted **without flowing water** and shall be conducted by starting the pump automatically. An electric pump shall run a minimum of 10 minutes and diesel pump shall run a minimum of 30 minutes.
- An **annual** test of each pump assembly shall be conducted under minimum rated and peak flows of the fire pump by controlling the quantity of water discharged through approved test devices.

C. Water Storage Tank:

Temperature Alarms:

- Low water temperature alarms shall be tested **monthly** cold weather only.

High Temperature Limit Switches:

- High water temperature limit switches on tank heating system shall be tested **monthly** whenever the heating system is in service.

Water Level Alarms:

- High and low water level alarms shall be tested **semi-annually**.

Level Indicator:

- Level indicator shall be tested every **5 years** for accuracy and freedom of movement.

Pressure Gauges:

- Pressure gauges shall be tested every **5 years** with a calibrated gauge according the manufacturer's manual. Gauges not accurate to within 3 percent of the scale of gauge being tested shall be recalibrated or replaced.

D. Valve and Valve Component:

Main Drains Test:

- This test shall be conducted **annually** at each water-based fire protection system riser to determine whether there has been change in the condition of the water supply piping and control valves.
- Systems where the sole water supply is through a backflow preventer and/or pressure reducing valves, the main drain test of at least one system downstream of the device shall be conducted on a **quarterly** basis.

Dry Pipe Valves / quick – opening Devices:

- The **priming water** level shall be tested **quarterly**. High priming water levels can affect the operation of supervisory air or nitrogen pressure maintenance device. Testing the water level is done by opening the priming level test valve, if water flows, drain it, close the valve when water stops flowing and air discharges, if air discharges when the valve is opened, the priming water level could be too low. To add priming water, refer to manufacturer's instructions.
- **Low air pressure alarms** shall be tested **quarterly** in accordance with the manufacturer's instructions.
- **Quick-opening devices** shall be tested **quarterly** following the below procedures:
 - Close the system control valve, open the main drain valve and keep it in the open position, verify that the quick-opening device control valve is open. Open the inspector's test valve. A burst of air from device indicates that it has tripped. Close the device's control valve. Return the device to service in accordance with manufacturer's instructions and return the system to service.
 - Each dry pipe valve shall be **trip tested annually** during warm weather. Should be tested in the spring to allow time before the onset of cold weather for all water that has entered the system or condensation to drain to low points or back to the valve.
 - **Every 3 yrs** and whenever the system is **altered**, the dry pipe valve shall be trip tested with the control valve **fully open** and the quick – opening device in service.
 - **A full flow trip test** - requires at least two individuals, one of whom is situated at the **dry pipe valve** while the other is at the **inspector's test**. If possible they should in communication with each other. A full flow trip test is conducted as follows: **1-** The main drain valve is fully opened to clean any

accumulated scale or foreign material from the supply water piping. The main drain valve then closed. **2-** The system air or nitrogen pressure and the supply water pressure are recorded. **3-** The system air or nitrogen pressure is relieved by opening the inspector's test valve completely. Concurrent with opening the valve, both testers start their stopwatches. If two-way communication is not available, the tester at the dry valve is to react to the start of downward movement on the air pressure gauge. **4-** Testers at the dry pipe valve note the air pressure at which the valve trips and note the tripping time. **5 -** Testers at the inspector's test note the time at which water flows steadily from the test connection. This time is noted for comparison purposes to previous tests and is not meant to be a specific pass/fail criterion. Note that NFPA 13, does not require water delivery in 60 seconds for all systems. **6-** When clean water flows, the test is terminated by closing the system control valve. **7-** The air or nitrogen pressure and the time elapsed are to be recorded as follows:

- a-** from the complete opening of the test valve to the tripping of the valve,
- b-** from the complete opening of inspector's valve to the start of steady flow from the test connection.

8- All low point drain are opened and then closed when water ceases to flow. The dry pipe valve and quick-opening are reset, if installed, in accordance with the manufacturer's instruction, and the system is returned to service.

Pressure reducing and relief valves:

Standpipe Systems:

- At 5 year intervals, a full flow test shall be conducted on pressure reducing valves and shall be compared to previous test result and the results from the original installation or acceptance test. Annually, a partial flow test shall be conducted with a flow rate great enough to lift the valve seat. (For reference Section 12.5.1.3 NFPA 25)

Circulation Relief Valves:

- During the **annual** fire pump test, the closure of circulation relief valve shall be verified to be in accordance with the manufacturer's specifications.

Pressure Relief Valves:

- During the **annual** fire pump flow test, the pressure of relief valve shall be verified to be correctly adjusted and set to relieve at the correct pressure and to close below that pressure setting.

Standpipe systems equipped with hose valves:

- A full flow test shall be conducted on each valve at **5 years** intervals and shall be compared to previous test results.

Backflow prevention assemblies installed in fire protection system piping shall be tested **annually** in accordance with the following:

- 1- A forward flow test shall be conducted at the system demand, including hose stream demand, where hydrants or inside hose stations are located downstream of the backflow preventer.
- 2- A backflow performance test, as required by the authority having jurisdiction shall be conducted at the completion of the forward flow test.

Control Valves:

- Each control valve shall be operated **annually** through its full range and returned to its normal position. This test shall be conducted every time the valve is closed. Post indicator and outside screw and yoke valves shall be backed a one-quarter turn from the fully open position to prevent jamming.
- Valve **supervisory switches** shall be tested **semiannually**. A distinctive signal shall indicate movement from the valve's normal position during either the first two revolutions of a hand wheel or when the stem of the valve has moved no more than 1/5th of the distance from its normal position.

Gauges:

- Gauges shall be replaced **every 5 yrs** or tested **every 5 yrs** by comparison with a calibrated gauge. Gauges that is not accurate with in 3% of the full scale shall be recalibrated or replaced.

High Temperature Limit Switches:

- High water temperature limit switches on tank heating system shall be tested **monthly** whenever the heating system is in service.

Hose Nozzle 1962 (4.1.2) All nozzles shall be inspected after each use and at least **annually**. The inspection shall include verification of waterway clear of obstructions, no damage to tip, full operation of adjustments such as pattern selection, proper operation of shutoff valve, no missing parts and the thread gasket in good condition. If the nozzle fails the inspection for any reason, it shall be removed from service and repaired or replaced.

Hose Storage device 1962 , Hose in storage shall be kept out of direct sunlight and in well ventilated location. Hose shall be stored only after has been properly inspected, service tested if required cleaned dried and rolled annually.

Hose 1962, Service testing of hose is undertaken to confirm its suitability for continued use. Because there is a potential for catastrophic failure during these test, it is vital that adequate safety precautions be taken.

The service test pressure for hose manufactured prior to July 1987 to meet the requirements of the 1979 and previous edition of NFPA 1961 will be 11/2 – 21/2 single jacket hose with service test pressure 150 psi. Hose manufactured in July 1987 and after to meet the requirements of the 1987 and subsequent editions of NFPA 1961, Standard on fire Hose, is stenciled on each length of hose and read "Service Test to ...PSI per NFPA 1962"

In service hose designed for occupant use only shall be removed and service tested at intervals not exceeding 5 years after installation and every e years thereafter.

Pressure reducing and relief valves:

Standpipe Systems:

- At 5 year intervals, a full flow test shall be conducted on pressure reducing valves and shall be compared to previous test result and the results from the original installation or acceptance test. Annually, a partial flow test shall be conducted with a flow rate great enough to lift the valve seat. (For reference Section 12.5.1.3 NFPA 25)

Circulation Relief:

- During the **annual** fire pump test, the closure of circulation relief valve shall be verified to be in accordance with the manufacturer's specifications.

Pressure Relief Valves:

- During the **annual** fire pump flow test, the pressure of relief valve shall be verified to be correctly adjusted and set to relieve at the correct pressure and to close below that pressure setting.

Standpipe systems equipped with hose racks

- A full flow test shall be conducted on each valve at **5 years** intervals and shall be compared to previous test results.

Hydrostatic test (5 years) See Fire Department Code section 905.12.1

Upon order of the commissioner, but at least once every 5 years, the standpipe system shall be subjected to a hydrostatic pressure test and a flow test to demonstrate its suitability for department use. These tests shall be conducted in compliance with the requirements of the rules and shall be conducted at the owner's risk, by his or her representative before a representative of the department.



Flow test (3 years) See Fire Department Code section 905.12.2

At least once every three (3) years, *standpipe systems* with *pressure reducing devices* installed shall be flow tested with a minimum actual flowing discharge of 250 *gpm*. These tests shall be conducted by a master fire suppression contractor who shall provide the *Department* five (5) business days notice of the date and time of the test. The *Department* may witness these tests at its discretion.

III. MAINTENANCE

A. Standpipe Systems:

Valves (all types)

Control Valves:

- The operating stems of outside screw and yoke valves shall be lubricated

annually. The valve then shall be completely closed and reopened to test its operation and distribute the lubricant.

Low point drains (dry pipe system):

- Shall be drained after each operation and before the onset of freezing weather conditions.

Hose Connections 6.2.2

The following devices must be maintained and repaired annually:

- missing cap, valve handles, restricting device and cap gaskets must be replaced.
- damaged fire hose connection, deteriorated cap gaskets and leaking valves must be repaired.
- manual, semiautomatic, or dry standpipe that does not operate smoothly must be repaired or lubricated.

B. Fire Booster and Special Service Pumps:

- A preventive maintenance program shall be maintained on all components of the pump assembly in accordance with manufacturer's recommendations. If there is no manufacturer's recommendations for preventive maintenance use Table 8.5.3 of NFPA 25, 2002.

C. Water Storage Tank:

Water Level:

- Tank shall be maintained full or at the designed water level.

Drain Silt

- Silt shall be removed during interior inspection (semiannually) or more frequently as needed to avoid accumulation to the level of the tank outlet.

Embankment-Supported Coated Fabric (ESCF) Suction Tanks:

- The maintenance of ESCF tanks shall be done according the tank manufacturer manual.

D. Valve and Valve Component:

Control Valves:

- The operating stems of outside screw and yoke valves shall be lubricated **annually.** The valve then shall be completely closed and reopened to test its operation and distribute the lubricant.

Pre-action/ Valves

- During the annual trip test, the interior of the pre-action or deluge valve shall be cleaned thoroughly and the parts replaced or repaired as necessary.

Dry Pipe Valves / Quick – Opening Devices

- During the annual trip test, the interior of the pre-action or deluge valve shall be cleaned thoroughly and the parts replaced or repaired as necessary.

10.2 Inspection Reference Guide

Reference Guide Defining Individuals Qualified as to Whom Can Perform Inspection, Testing and Maintenance for Standpipe and Hose Systems
These check lists will be given to you by the FDNY examiners when taking this test at the Fire Department.

C of F	Certificate of Fitness S-13 City Wide Standpipe System
Engineer	Refrigeration Operating Engineer (Q-01 & Q-99), NYC High Pressure Operating Engineer, NYS High Pressure Operating Engineer with S-13 C of F *(For employees of a single or multiple properties under common Ownership employed by the same building owner/management company)
MFSPC	Master Fire Suppression Piping Contractor License (A or B) with S-13 C of F.
MP	Master Plumber License (MP) with S-13 C of F.
¹ Must have an S-12 Certificate of Fitness for City Wide Sprinkler System. ² S-95 Supervision for Fire alarm Systems & other related systems. ³ Follow testing requirement. ⁴ Record must be maintained to be checked annually. ⁵ Must be performed once annually by licensed contractor. ⁶ Independent standpipe system.	

Components	May be performed by			
	C of F	Engineer	MFSPC	MP
I. INSPECTION				
A. Standpipe Systems				
WEEKLY (52)				
Gauge (dry) Non supervised	Yes	Yes	Yes	Yes
MONTHLY (12)				
Gauge (dry) supervised	Yes	Yes	Yes	Yes
Gauge – Wet pipe system	Yes	Yes	Yes	Yes
QUARTERLY (4)				
Alarm devices 5.2.6	Yes	Yes	Yes	Yes
Pressure regulating device 12.1	Hose connections	Yes	Yes	Yes
	Hose racks			
Piping 6.2.1	Piping	Yes	Yes	Yes
	Hanger/seismic bracing (floor level)			
	Supervisory device			
ANNUALLY (1)				
Buildings – (prior to freezing weather) exterior of building should be examined to prevent freeze-ups fire suppression piping.	No	No	Yes	Yes
Cabinet	No	No	Yes	Yes
Hanger/seismic bracing (floor level)	No	No	Yes	Yes
Hose storage device (Hose racks)	No	No	Yes	Yes
Hose	No	No	Yes	Yes
B. Fire, Booster and Special Service Pumps				
WEEKLY (52)				
Pump, house, heating ventilating louvers	Yes	Yes	Yes	Yes
Fire pump system	Yes	Yes	Yes	Yes
		Tank level	Yes	Yes

Diesel Engine System	Fuel	Tank float switch				
		Solenoids valve operation				
		Water in the fuel sys				
		Flexible hoses and connectors				
		Piping				
	Lubrication system	Tank vents & overflow piping unobstructed				
		Oil level				
		Lube oil heater				
	Cooling system	Crankcase breather				
		Level				
		Adequate cooling water to heat exchanger				
		Water pumps				
		Cond. Of flexible hoses & connection				
	Exhaust system	Jacket water heater				
		Leakage				
Drain condensate trap						
Hangers & supports						
Electrical system	Flexible exhaust section					
	General inspection					
	Operation of safeties & alarms					
	Circuit breakers or fuses					
MONTHLY (12)						
Diesel Engine System		Circuit breakers or fuses	Yes	Yes	Yes	Yes
		Charger & charge rate	Yes	Yes	Yes	Yes
QUARTERLY (4)						
Diesel Engine System	Exhaust system	Insulation & fire hazards	Yes	Yes	Yes	Yes
	Electrical system	Wire chafing where subject to movement				
SEMIANNUALLY (2)						
Diesel Engine System	Electrical system	Operation of safeties and alarms	Yes	Yes	Yes	Yes
ANNUALLY (1)						
Fire pump system	Check accuracy of pressure gauges and sensors		No	No	Yes	Yes
	Check pump shaft endplay, coupling alignment					
	Wet pit suction screens					
Diesel Engine System	Cooling sys	Inspect duct work, clean louvers (combustion air)	No	No	Yes	Yes
Electrical system 2	Inspect emergency manual starting means (without power)		No	No	Yes	Yes
	Tighten electrical connections as necessary					
	Lubricate mechanical moving parts (excluding starters & relays)					
	Calibrate pressure switch settings					
C. Water Storage Tank						
DAILY (365)						
Water temperature – without low temperature alarms (cold weather)			Yes	Yes	Yes	Yes
Heating System – without low temperature alarms (cold weather)			Yes	Yes	Yes	Yes
WEEKLY (52)						
Water temperature - with low temperature alarms (cold weather)			Yes	Yes	Yes	Yes

Heating system – with low temperature alarms (cold weather)			Yes	Yes	Yes	Yes
MONTHLY (12)						
Condition of water in tank – with out water level alarms (cold weather)			Yes	Yes	Yes	Yes
Water tanks - level (without water level alarms)			Yes	Yes	Yes	Yes
Air pressure - (with out supervised air pressure source)			Yes	Yes	Yes	Yes
QUARTERLY (4)						
Condition of water in tank - with water level temperature alarms (cold weather below 40°F)			Yes	Yes	Yes	Yes
Water – level (with water level alarms)			Yes	Yes	Yes	Yes
Air pressure – (with supervised air pressure source)			Yes	Yes	Yes	Yes
Tank – exterior	Support structure		Yes	Yes	Yes	Yes
	Catwalks and ladders					
	Surrounding area					
ANNUALLY (1)						
Embankment-supported coated fabric (ESCF) suction tanks			No	No	Yes	Yes
Hoops and grillage of wooden tanks (AKA Dunnage)			No	No	Yes	Yes
Expansion Joints			No	No	Yes	Yes
3 YEARS						
Interior – (steel tanks without corrosion protection)			No	No	Yes	Yes
5 YEARS						
Interior - all other types of tanks			No	No	Yes	Yes
D. Valve and Valve component						
DAILY (365)						
Dry valve - valve enclosure without temperature alarm(during cold weather)			Yes	Yes	Yes	Yes
Dry pipe valves and quick opening devices – valve enclosure without temperature alarm (during cold weather)			Yes	Yes	Yes	Yes
WEEKLY (52)						
Control Valves		Sealed	Yes	Yes	Yes	Yes
dry valves - valve enclosure equipped with low temperature alarms (during cold weather)			Yes	Yes	Yes	Yes
Dry pipe valves and quick opening devices – valve enclosure equipped with low temperature alarms (during cold weather) N20			Yes	Yes	Yes	Yes
Pressure reducing & Relief valves	Fire Pumps	Casing relief valves	Yes	Yes	Yes	Yes
		Pressure relief valves				
Backflow Prevention assemblies		reduced pressure	Yes	Yes	Yes	Yes
		reduced pressure detectors				
MONTHLY (12)						
Control Valves		Locked	Yes	Yes	Yes	Yes
		Tamper switches				
Alarm valves		Exterior	Yes	Yes	Yes	Yes
Deluge valves – Exterior			Yes	Yes	Yes	Yes
Dry pipe valves and quick opening devices - Exterior			Yes	Yes	Yes	Yes
Pressure regulating & Relief valves	Fire Pumps	Casing relief valves	Yes	Yes	Yes	Yes
		Pressure relief valves				
Backflow Prevention assemblies (secured with locks or electrically supervised)		reduced pressure	Yes	Yes	Yes	Yes
		reduced pressure detectors				
QUARTERLY (4)						
Pressure regulating & Relief valves		Hose connections	Yes	Yes	Yes	Yes
		Hose racks				
		Floor markings				

	calibration				
	Setting notches				
Fire department connections	Caps combination with standpipe/sprinkler (should be painted yellow	Yes	Yes	Yes	Yes
	Swivel turn freely				
	Ball drip				
	Signage				
Hose Valve		Yes	Yes	Yes	Yes
ANNUALLY (1)					
Dry and deluge valves – interior (when trip test is conducted)		No	No	Yes	Yes
Dry pipe valves and quick opening devices - interior (when trip test is conducted)		No	No	Yes	Yes
Check valves (deluge valves, dry pipe valves/quick-opening devices) exterior		No	No	Yes	Yes
Standpipe system *		No	No	Yes	Yes
5 YEARS					
Alarm valves	Interior	No	No	Yes	Yes
	Strainers, filters, orifices				
Check Valves - Interior		No	No	Yes	Yes
Deluge valves	Strainers, filters, orifices	No	No	Yes	Yes
Dry pipe valves and quick opening devices	Strainers, filters, orifices	No	No	Yes	Yes

10.3 Testing Reference Guide

Reference Guide Defining Individuals Qualified as to Whom Can Perform Inspection, Testing and Maintenance for Standpipe and Hose Systems. These Reference Guide will be given to you by the FDNY examiners when taking this test at the Fire Department.

C of F	Certificate of Fitness S-13 City Wide Standpipe System
Engineer	Refrigeration Operating Engineer (Q-01 & Q-99), NYC High Pressure Operating Engineer, NYS High Pressure Operating Engineer with S-13 C of F (For employees of a single or multiple properties under common Ownership employed by the same building owner/management company)
MFSPC	Master Fire Suppression Piping Contractor License (A or B) with S-13 C of F.
MP	Master Plumber License (MP) with S-13 C of F.
<ol style="list-style-type: none"> ¹ Must have an S-12 Certificate of Fitness for City Wide Sprinkler System. ² S-95 Supervision for Fire alarm Systems & other related systems. ³ Follow testing requirement. ⁴ Record must be maintained to be checked annually. ⁵ Must be performed once annually by licensed contractor. 	

Components	May be performed by			
	C of F	Engineer	MFSPC	MP

II. TEST

A. Standpipe Systems

QUARTERLY (4)

Alarm Devices	water flow alarms	Yes	Yes	Yes	Yes
	Supervisory devices	Yes	Yes	Yes	Yes

SEMIANNUALLY (2)

Alarm Devices (Vane type water flow devices)	No	No	Yes	Yes
--	-----------	-----------	------------	------------

5 YEARS

Gauges - Remove & send for calibration test or replace as Required	No	No	Yes	Yes
--	-----------	-----------	------------	------------

B. Fire, Booster and Special Service Pumps

WEEKLY (52)

Pump operation - No-flow condition	No	Yes	Yes	Yes
Fire pump - Electric pump (minimum of 10 minutes)	No	Yes	Yes	Yes
Diesel Engine system	Solenoids valve operation	No	Yes	Yes

MONTHLY (1)

Electrical system ²	Isolating switch & circuit breaker	No	Yes	Yes	Yes
Battery system	Specific gravity or state of charge				

SEMIANNUALLY (2)

Electrical system ²	Operating manual starting means (electrical)	No	Yes⁴	Yes	Yes	
Diesel Engine System	Cooling system	No	Yes	Yes	Yes	
	fuel					Antifreeze protection level
	Electrical system					Tank float switch
	Solenoids valve operation					
	Operation of safeties and alarms					

ANNUALLY (1)					
Pump operation - Flow condition		No	No	Yes	Yes
Electrical system ²	Trip circuit breaker(if mechanism provided)	No	No	Yes	Yes
	Operate emergency manual starting means(without power)				
Exhaust system	Excessive back pressure	No	No	Yes	Yes
Diesel Engine System	Tank vents and overflow piping unobstructed	No	No	Yes	Yes
C. Water Storage Tank					
MONTHLY (12)					
Temperature alarms (cold weather)		No	Yes⁵	Yes	Yes
High temperature limit switches (cold weather)		No	Yes⁵	Yes	Yes
SEMIANNUALLY (2)					
Water level alarms		No	Yes⁵	Yes	Yes
5 YEARS					
Level indicators		No	Yes⁵	Yes	Yes
Pressure gauges		No	Yes⁵	Yes	Yes
D. Valve and Valve Component					
QUARTERLY (4)					
Main drain (where the sole water supply is through a backflow preventer and/or pressure reducing valves)		No	Yes	Yes	Yes¹
Dry pipe valves and Quick Opening devices	Priming water	No	Yes⁵	Yes	Yes
	Low air pressure alarm				
	Quick-opening devices				
SEMIANNUALLY (2)					
Control Valves	Supervisory	No	Yes⁵	Yes	Yes
ANNUALLY (1)					
Hose Nozzle 1962		No	No	Yes	Yes
Hose Storage device , racks 1962		No	No	Yes	Yes
Standpipe - hose valve		No	Yes	Yes	Yes
Main drain		No	No	Yes	Yes¹
Dry pipe valves and Quick Opening devices	Trip test	No	No	Yes	Yes
Control Valves	Position	No	No	Yes	Yes
	Operation				
Pressure reducing and Relief valves	Circulation relief	No	No	Yes	Yes
	Pressure relief valves				
Backflow prevention Assemblies		No	No	Yes	Yes
3 YEARS					
Hose 1962		No	Yes	Yes	Yes
Combined Sprinkler/Standpipe- hose valve		No	No	Yes	Yes
Dry pipe valves and Quick Opening devices	Full flow trip test	No	No	Yes	Yes
5 YEARS					
Hose 1962		No	Yes	Yes	Yes
Hydrostatic Test 6.3.2		No	No	Yes	Yes
Flow test 6.3.1		No	No	Yes	Yes
Gauges - Remove & send for calibration test or replace as required		No	Yes⁴	Yes	Yes
Pressure reducing & Relief valves	Standpipe systems	No	Yes⁴	Yes	Yes
	Hose connections				
	Hose Storage device, racks				

10.4 Maintenance Reference Guide

Reference Guide Defining Individuals Qualified as to Whom Can Perform Inspection, Testing and Maintenance for Standpipe and Hose Systems.

These Reference Guide will be given to you by the FDNY examiners when taking this test at the Fire Department.

C of F	Certificate of Fitness S-13 City Wide Standpipe System
Engineer	Refrigeration Operating Engineer (Q-01 & Q-99), NYC High Pressure Operating Engineer, NYS High Pressure Operating Engineer with S-13 C of F (For employees of a single or multiple properties under common Ownership employed by the same building owner/management company)
MFSPC	Master Fire Suppression Piping Contractor License (A or B) with S-13 C of F.
MP	Master Plumber License (MP) with S-13 C of F.
¹ Must have an S-12 Certificate of Fitness for City Wide Sprinkler System. ² S-95 Supervision for Fire alarm Systems & other related systems. ³ Follow testing requirement. ⁴ Record must be maintained to be checked annually. ⁵ Must be performed once annually by licensed contractor.	

Components	May be performed by			
	C of F	Engineer	MFSPC	MP

III. MAINTENANCE

A. Standpipe Systems

ANNUALLY (1)					
Valves (all types)	Control valves	No	No	Yes	Yes
	Dry pipe valves /quick opening devices	No	No	Yes	Yes
Low point drains - (Dry pipe systems)		No	No	Yes	Yes
Hose Connections 6.2.2	Lubricate	No	Yes	Yes	Yes
	Repair	No	Yes	Yes	Yes
	Replace	No	Yes	Yes	Yes

5 YEARS					
Obstruction Investigation		No	No	Yes	Yes

B. Fire, Booster and Special Service Pumps

WEEKLY (52)					
Diesel engine system	Fuel	Clean water in the system	No	Yes⁵	Yes
MONTHLY (12)					
Diesel engine system	Battery sys	Remove corrosion, case exterior	No	Yes⁵	Yes
QUARTERLY (4)					
Diesel engine system	Fuel	Clean Strainer, filter or dirt leg or combination	No	Yes⁵	Yes
	Lubricating sys	Crankcase breather			
	Cooling sys	Water strainer			
	Battery sys	Remove corrosion, case exterior clean & dry			

SEMI-ANNUALLY (2)					
		Boxes, panels and cabinets	No	Yes⁵	Yes

Diesel engine system	Electrical sys	Circuit breakers or fuses				
ANNUALLY (1)						
Hydraulic			No	No	Yes	Yes
Pump system	Lubricate pump bearings		No	No	Yes	Yes
	Check accuracy of pressure gauges & sensors					
	Wet pit suction screens (after each pump opera.)					
Mechanical transmission	Lubricate coupling		No	No	Yes	Yes
	Lubricate right angle gear drive					
Electrical system	Grease motor bearings		No	No	Yes	Yes
Controller, various components			No	No	Yes	Yes
Motor			No	No	Yes	Yes
Diesel engine system various components	Cooling sys	Inspect duct work	No	No	Yes	Yes
		clean louvers				
	Rod out heat exchanger					
	Lubrication sys	Oil change				
		Oil filters				
Exhaust sys	Excessive back pressure					
C. Water Storage Tank						
Water level as required			No	Yes	Yes	Yes
SEMIANNUALLY (2)						
Drain silt			No	Yes⁵	Yes	Yes
ANNUALLY (1)						
Embankment-supported coated fabric (ESCF) suction tanks			No	No	Yes	Yes
D. Valve and Valve Component						
ANNUALLY (1)						
Control valves			No	No	Yes	Yes
Dry Pipe Valves and Quick-Opening Devices			No	No	Yes	Yes

10.5 Inspection, Maintenance & Testing Notification Activities

Red Tag	Notify FDNY & owner immediately (Shall be fixed Immediately) FC 901.7
Orange Tag	Notify FDNY & owner if deficiency is not corrected after 30 days
Yellow Tag	Notify FDNY & owner if deficiency is not corrected after 30 days

<u>Components</u>	<u>Inspection Activities</u> (Reference NFPA 25 – 2002)	<u>Notification of System Shut Down</u>		<u>Components Checked Satisfactory</u> (Yes or No) If No, explain
		Impairment - Red Tag	Critical Deficiency - Orange Tag	
I. INSPECTION				
A. Standpipe & Hose Systems				
Standpipe system Shut down	Partial or Full shut down	Red	<input type="checkbox"/> Yes <input type="checkbox"/> No	
No Access	Control Valves - Inaccessible for more than 30 days	Red	<input type="checkbox"/> Yes <input type="checkbox"/> No	
Piping	Leaking (6.2.1.)	Red	<input type="checkbox"/> Yes <input type="checkbox"/> No	
Piping	Poor condition/external corrosion, mechanical damage, not properly aligned, external loads	Orange	<input type="checkbox"/> Yes <input type="checkbox"/> No	
Hose	Cuts, couplings not of compatible threads (6.2.1) NFPA 1962	Orange	<input type="checkbox"/> Yes <input type="checkbox"/> No	
Hose	Deterioration, no gasket or damaged gaskets (6.2.1) NFPA 1962	Orange	<input type="checkbox"/> Yes <input type="checkbox"/> No	
Hose	Mildew present, corrosion present, hose not connected (6.2.1) NFPA 1962	Yellow	<input type="checkbox"/> Yes <input type="checkbox"/> No	
Hose nozzle	Missing, broken parts or thread gasket damaged (6.2.1) NFPA 1962	Orange	<input type="checkbox"/> Yes <input type="checkbox"/> No	
Hose storage	Hose not properly racked or rolled, nozzle clip missing, nozzle not contained, damaged obstructed (6.2.1) NFPA 1962	Orange	<input type="checkbox"/> Yes <input type="checkbox"/> No	
cabinet	Corroded or damaged parts, not easy to open, not accessible, not identified, door glazing in poor condition, lock not functioning in break glass type, valve, hose nozzle, fire extinguisher, etc, not readily accessible (6.2.1) NFPA 1962	Orange	<input type="checkbox"/> Yes <input type="checkbox"/> No	
Pipe and fittings	Leaking (5.2.2.1)	Red	<input type="checkbox"/> Yes <input type="checkbox"/> No	
Pipe and fittings	Poor condition/external corrosion, mechanical damage, not properly aligned, external loads (5.2.2.1, 5.2.2.2)	Yellow	<input type="checkbox"/> Yes <input type="checkbox"/> No	

Pipe and fittings	Subject to freezing conditions	Orange	<input type="checkbox"/> Yes <input type="checkbox"/> No	
Hangers & seismic braces	Damaged or loose (5.2.3.2)	Yellow	<input type="checkbox"/> Yes <input type="checkbox"/> No	
Gauges	Poor Condition (5.2.4.1)	Yellow	<input type="checkbox"/> Yes <input type="checkbox"/> No	
Gauges	Not showing normal water/air pressure (5.2.4.1, 5.2.4.2)	Yellow	<input type="checkbox"/> Yes <input type="checkbox"/> No	
Building	Prior to freezing weather – exposed piping exposed to freezing (5.2.5)	Yellow	<input type="checkbox"/> Yes <input type="checkbox"/> No	
Building	Found during potential for freezing weather weather-exposed to freezing (5.2.5)	Orange	<input type="checkbox"/> Yes <input type="checkbox"/> No	
Alarm devices	Physical damage apparent (5.2.6)	Yellow	<input type="checkbox"/> Yes <input type="checkbox"/> No	
Hydraulic nameplate	Not legible or missing (5.2.7)	Yellow	<input type="checkbox"/> Yes <input type="checkbox"/> No	

B. Private Fire Service Mains

Exposed piping	Leaking (7.2.2.1.2)	Red	<input type="checkbox"/> Yes <input type="checkbox"/> No	
Exposed piping	Mechanical damage, corroded or not properly restrained (7.2.2.1.2)	Orange	<input type="checkbox"/> Yes <input type="checkbox"/> No	
Mainline strainers	Plugged or fouled (7.2.2.3)	Red	<input type="checkbox"/> Yes <input type="checkbox"/> No	
Mainline strainers	Corroded (7.2.2.3)	Orange	<input type="checkbox"/> Yes <input type="checkbox"/> No	
Dry barrel, Wet barrel & wall hydrant	Inaccessible, barrel contains ice, cracks in barrel (7.2.2.4)	Red	<input type="checkbox"/> Yes <input type="checkbox"/> No	
Dry barrel, wet barrel & wall hydrant	Barrel contains water, improper drainage from barrel, leaks at outlets or top of hydrant (7.2.2.4)	Orange	<input type="checkbox"/> Yes <input type="checkbox"/> No	
Dry barrel, wet barrel & wall hydrant	Tightness of outlets, worn nozzle threads, worn operating nut, missing wrench (7.2.2.4)	Yellow	<input type="checkbox"/> Yes <input type="checkbox"/> No	
Monitor nozzles	Damaged, corroded or leaking (7.2.2.6)	Orange	<input type="checkbox"/> Yes <input type="checkbox"/> No	
Hose/hydrant houses	Inaccessible (7.2.2.7)	Red	<input type="checkbox"/> Yes <input type="checkbox"/> No	
Hose/hydrant houses	Damaged (7.2.2.7)	Orange	<input type="checkbox"/> Yes <input type="checkbox"/> No	
Hose/hydrant houses	Not fully Equipped (7.2.2.7)	Orange	<input type="checkbox"/> Yes <input type="checkbox"/> No	

C. Fire and Special Service Pumps

Pump house/room	Heat not adequate, temperature less than 40 (less than 70 for diesel pumps without engine heaters) (8.2.2)	Orange	<input type="checkbox"/> Yes <input type="checkbox"/> No	
Pump house/room	Ventilating louvers not free to operate (8.2.2)	Orange	<input type="checkbox"/> Yes <input type="checkbox"/> No	
Pump system	Suction, discharge or bypass valves not fully open, pipe leaking, suction line & system line pressure not normal, wet pit suction screens obstructed (8.2.2)	Red	<input type="checkbox"/> Yes <input type="checkbox"/> No	
Pump system	Suction reservoir not full, wet pit suction screens missing (8.2.2)	Orange	<input type="checkbox"/> Yes <input type="checkbox"/> No	
Electrical system	No electrical power - controller pilot light not illuminated, transfer switch pilot light not illuminated, isolating switch not closed, reverse phase alarm pilot light on or normal	Red	<input type="checkbox"/> Yes <input type="checkbox"/> No	

	phase light is off, oil level in vertical motor sight glass not normal (8.2.2)			
Electrical system	Circuit breakers and fuses over two years old (8.2.2)	Orange	<input type="checkbox"/> Yes <input type="checkbox"/> No	
Electrical system	Electrical power is provided – controller pilot light not illuminated, transfer switch pilot light not illuminated, reverse phase alarm pilot light on or normal phase light is not illuminated (8.2.2)	Yellow	<input type="checkbox"/> Yes <input type="checkbox"/> No	
Diesel engine system	Fuel tank less than two-thirds full, controller selector switch not in auto position, battery voltage readings not normal, battery charging current not normal, battery pilot lights off or battery failure pilot lights on alarm pilot lights are on, engine running time meter not reading, oil level in right angle gear drive not normal, crankcase oil level not normal, cooling water level not normal, electrolyte level in batteries not normal, battery terminals corroded, water-jacket heater not operating (8.2.2)	Orange	<input type="checkbox"/> Yes <input type="checkbox"/> No	
Steam System	Steam pressure gauge reading not normal (8.2.2)	Orange	<input type="checkbox"/> Yes <input type="checkbox"/> No	

C. Water Storage Tanks

Water level	Water level and /or condition not correct (9.2.1)	Orange	<input type="checkbox"/> Yes <input type="checkbox"/> No	
Air pressure	Air pressure in pressure tanks not correct (9.2.2)	Red	<input type="checkbox"/> Yes <input type="checkbox"/> No	
Heating system	heating system not operational, water temperature below 40 (9.2.3)	Orange	<input type="checkbox"/> Yes <input type="checkbox"/> No	
Exterior	Tank exterior, supporting structure, vents, foundation, catwalks or ladders where provided damaged (9.2.5.1)	Yellow	<input type="checkbox"/> Yes <input type="checkbox"/> No	
Exterior	Area around tank has fire exposure hazard in form of combustible storage, trash, debris, brush or material (9.2.5.2)	Yellow	<input type="checkbox"/> Yes <input type="checkbox"/> No	
Exterior	Accumulation of material on or near parts that could result in accelerated corrosion or rot (9.2.5.2)	Yellow	<input type="checkbox"/> Yes <input type="checkbox"/> No	
Exterior	Ice buildup on tank and support (9.2.5.2)	Orange	<input type="checkbox"/> Yes <input type="checkbox"/> No	
Exterior	Erosion exists on exterior sides or top of embankments supporting coated fabric tanks (9.2.5.2)	Yellow	<input type="checkbox"/> Yes <input type="checkbox"/> No	
Exterior	Expansion joints leaking or	Orange	<input type="checkbox"/> Yes <input type="checkbox"/> No	

	cracking (9.2.5.3)			
Exterior	Hoops and grills of wooden tanks in poor condition (9.2.5.4)	Yellow	<input type="checkbox"/> Yes <input type="checkbox"/> No	
Exterior	Exterior painted, coated, or insulated surfaces of tanks or supporting structure degraded (9.2.5.5)	Yellow	<input type="checkbox"/> Yes <input type="checkbox"/> No	
Interior (pressure tanks or steel tanks w/o corrosion protection every 3 years, all others every 5 years)	Pitting, corrosion, spalling , rot other forms of deterioration, waste materials exist, aquatic growth, local or general failure of interior coating (9.2.6.3)	Yellow	<input type="checkbox"/> Yes <input type="checkbox"/> No	
Interior (pressure tanks or steel tanks w/o corrosion protection every 3 years, all others every 5 years)	voids beneath floor with stand in the middle of tanks on ring type foundations (9.2.6.5)	Yellow	<input type="checkbox"/> Yes <input type="checkbox"/> No	
Interior (pressure tanks or steel tanks w/o corrosion protection every 3 years, all others every 5 years)	Heating system components or piping in poor condition (9.2.6.6)	Yellow	<input type="checkbox"/> Yes <input type="checkbox"/> No	
Interior (pressure tanks or steel tanks w/o corrosion protection every 3 years, all others every 5 years)	Blockage of anti-vortex plate (9.2.6.7)	Red	<input type="checkbox"/> Yes <input type="checkbox"/> No	
Interior (pressure tanks or steel tanks w/o corrosion protection every 3 years, all others every 5 years)	Deterioration of anti-vortex plate (9.2.6.7)	Orange	<input type="checkbox"/> Yes <input type="checkbox"/> No	
D. Valves, Valve components, and Trim				
Gauges	Poor condition (12.2.8.1)	Yellow	<input type="checkbox"/> Yes <input type="checkbox"/> No	
Gauges	Not showing normal water/air pressure (12.2.8.1)	Orange	<input type="checkbox"/> Yes <input type="checkbox"/> No	
Control valve	Improper closed position (2.3.2.2)	Red	<input type="checkbox"/> Yes <input type="checkbox"/> No	
Control valve	Improper open position, leaking (12.3.2.2)	Orange	<input type="checkbox"/> Yes <input type="checkbox"/> No	
Control valve	Not sealed, locked or supervised, not accessible, no appropriated wrench if required, and no identification (12.3.2.2)	Yellow	<input type="checkbox"/> Yes <input type="checkbox"/> No	
Alarm valve	External physical damage, trim valves not in appropriate open of closed position, retard chamber or alarm drain leaking (12.4.1.1)	Orange	<input type="checkbox"/> Yes <input type="checkbox"/> No	
Alarm valve	Alarm valve, strainers , filters and restricted orifices not internally inspected after 5 years (12.4.1.2)	Orange	<input type="checkbox"/> Yes <input type="checkbox"/> No	
Check valve	Check valve not internally inspected after 5 years (12.4.2.1)	Orange	<input type="checkbox"/> Yes <input type="checkbox"/> No	

Valve enclosure	Not maintaining minimum 40°F temp. (12.4.3.1.1 , 12.4.4.1.1)	Orange	<input type="checkbox"/> Yes <input type="checkbox"/> No	
Deluge valve	External physical damage , trim valves not in appropriate open or closed position, valve seat leaking , (12.4.3.1.6)	Orange	<input type="checkbox"/> Yes <input type="checkbox"/> No	
Deluge valve	Electrical components not in service, (12.4.3.1.6)	Red	<input type="checkbox"/> Yes <input type="checkbox"/> No	
Deluge valve	Interior of pre-action valve/or deluge valve, strainers, filters, restricted orifices, and diaphragm chambers not internally inspected after 5 years (12.4.3.1.8)	Orange	<input type="checkbox"/> Yes <input type="checkbox"/> No	
Dry pipe valve/quick opening device (standpipe system)	External physical damage, trim valves not in appropriate open of closed position, intermediate chamber leaking (12.4.4.1.6)	Orange	<input type="checkbox"/> Yes <input type="checkbox"/> No	
Dry pipe valve/quick opening device	Dry pipe valve, strainers, filters and restricted orifices not internally inspected after 5 years (12.4.4.1.6)	Orange	<input type="checkbox"/> Yes <input type="checkbox"/> No	
Standpipe pressure regulating control valves	Not in open position, not maintaining down-stream pressures in accordance with the design criteria (12.5.1.1)	Red	<input type="checkbox"/> Yes <input type="checkbox"/> No	
FDNY 5 year test not conducted	As per Chapter 9 NYC Fire Code	Orange	<input type="checkbox"/> Yes <input type="checkbox"/> No	
Standpipe pressure regulating control valves	leaking, valve damaged, hand wheel missing or broken (12.5.3.1)	Orange	<input type="checkbox"/> Yes <input type="checkbox"/> No	
Hose valves	Leaking, visible obstructions, caps, hose threads, valve handle, cap gasket, no restricting device, damaged or in poor condition (12.5.5.1)	Orange	<input type="checkbox"/> Yes <input type="checkbox"/> No	
Deluge valve	Annual partial flow test results not available (12.5.1.3)	Orange	<input type="checkbox"/> Yes <input type="checkbox"/> No	
Backflow prevention assemblies	Reduced pressure assemblies differential-sensing valve relief port continuously discharging (12.6.1.2)	Orange	<input type="checkbox"/> Yes <input type="checkbox"/> No	
Fire Department connection	Not accessible, couplings & swivels damaged, do not rotate smoothly, Fire department connection clapper not operating properly or missing, (12.7.1)	Red	<input type="checkbox"/> Yes <input type="checkbox"/> No	
Fire Department connection	Not visible, plugs & caps or gaskets damaged or missing, check valve leaking, automatic drain not operating properly or missing (12.7.1)	Orange	<input type="checkbox"/> Yes <input type="checkbox"/> No	
Fire department connection	Missing identification sign (12.7.1)	Yellow	<input type="checkbox"/> Yes <input type="checkbox"/> No	

II. TEST

A. Standpipe & Hose Systems				
Hose storage device	Rack will not swing out of cabinet at least 90° (6.2.1, NFPA 1962)	Yellow	<input type="checkbox"/> Yes <input type="checkbox"/> No	
Standpipe System	Test results did not provide design pressure at required flow (6.3.1.1)	Orange	<input type="checkbox"/> Yes <input type="checkbox"/> No	
Standpipe System	No flow test done after 5 years (6.3.1.1)	Yellow	<input type="checkbox"/> Yes <input type="checkbox"/> No	
Dry standpipe, dry portion of wet standpipe and manual standpipe system	Test showed leaks (6.3.2)	Orange	<input type="checkbox"/> Yes <input type="checkbox"/> No	
Dry standpipe, dry portion of wet standpipe and manual standpipe system	No hydrostatic test done after 5 years (6.3.2)	Yellow	<input type="checkbox"/> Yes <input type="checkbox"/> No	
Gauges	Not replaced or calibrated in 5 years, not accurate within 3% of scale (5.3.2)	Yellow	<input type="checkbox"/> Yes <input type="checkbox"/> No	
Alarm devices	Pressure switch or vane type switch not functioning or no alarm (5.3.4)	Orange	<input type="checkbox"/> Yes <input type="checkbox"/> No	
Obstruction Investigation	No inspection of main and branch line after 5 years or inspection revealed presence of MIC, zebra mussels, rust and scale (13.2.1)	Yellow	<input type="checkbox"/> Yes <input type="checkbox"/> No	
B. Private Fire Service Mains				
Underground and exposed piping	No flow test done after 5 years or test results not comparable to previous (7.3.1)	Yellow	<input type="checkbox"/> Yes <input type="checkbox"/> No	
Dry barrel & wall hydrant	Hydrant did not flow clear or did not drain within 60 minutes (7.3.2.1, 7.3.2.4)	Yellow	<input type="checkbox"/> Yes <input type="checkbox"/> No	
Monitor nozzles	Did not flow acceptable amount of water or did not operate throughout their full range (7.3.3.1, 7.3.3.2)	Orange	<input type="checkbox"/> Yes <input type="checkbox"/> No	
C. Water Storage Tanks				
Interior testing	Tank coating did not pass adhesion, coating thickness or wet sponge test (9.2.7)	Yellow	<input type="checkbox"/> Yes <input type="checkbox"/> No	
Interior testing	Tank walls and bottom did not pass ultrasonic test (9.2.7)	Yellow	<input type="checkbox"/> Yes <input type="checkbox"/> No	
Interior testing	Tank bottom seams did not pass vacuum box test (9.2.7)	Yellow	<input type="checkbox"/> Yes <input type="checkbox"/> No	
Testing	Level indicator not tested after 5 years, lacked freedom of movement or not accurate (9.3.1)	Yellow	<input type="checkbox"/> Yes <input type="checkbox"/> No	
Testing	Low water temperature alarm did not pass test (9.3.3)	Yellow	<input type="checkbox"/> Yes <input type="checkbox"/> No	
Testing	High water temperature limit switch did not pass test (9.3.4)	Yellow	<input type="checkbox"/> Yes <input type="checkbox"/> No	
Testing	High and low water level alarms did not pass test (9.3.5)	Red	<input type="checkbox"/> Yes <input type="checkbox"/> No	

Gauges	Not tested in 5 years, not accurate within 3% of scale (9.3.6)	Yellow	<input type="checkbox"/> Yes <input type="checkbox"/> No	
D. Foam-Water Standpipe Systems				
Alarm devices	Water motor and gong not functioning (11.1.3.1.1, 11.3.1.1)	Orange	<input type="checkbox"/> Yes <input type="checkbox"/> No	
Alarm devices	Pressure switch or van type switch not functioning or no alarm (11.1.3.1.2, 11.3.1.2)	Orange	<input type="checkbox"/> Yes <input type="checkbox"/> No	
Operational Test	Fire detection system did not operate within requirements of NFPA #72 (11.3.2.4)	Orange	<input type="checkbox"/> Yes <input type="checkbox"/> No	
Operational Test	Test not done after 1 year (11.3)	Yellow	<input type="checkbox"/> Yes <input type="checkbox"/> No	
Operational Test	Nozzles are plugged (11.3.2.6.1)	Red	<input type="checkbox"/> Yes <input type="checkbox"/> No	
Operational Test	Nozzles are not correctly positioned (11.3.2.6.1)	Orange	<input type="checkbox"/> Yes <input type="checkbox"/> No	
Operational Test	Pressure readings are not comparable to original design requirements (11.3.2.7.3)	Orange	<input type="checkbox"/> Yes <input type="checkbox"/> No	
Operational Test	Manual actuation devices did not work properly (11.3.4)	Red	<input type="checkbox"/> Yes <input type="checkbox"/> No	
Operational Test	Foam sample did not pass concentration test (11.3.5)	Red	<input type="checkbox"/> Yes <input type="checkbox"/> No	
Obstruction Investigation	No inspection of main and branch line after 5 years or inspection revealed presence of MIC, zebra mussels, rust and scale (13.2.1)	Orange	<input type="checkbox"/> Yes <input type="checkbox"/> No	
E. Valves, Valve components, and Trim				
Alarm devices	Water motor and gong not functioning (12.2.7)	Orange	<input type="checkbox"/> Yes <input type="checkbox"/> No	
Alarm devices	Pressure switch or vane type switch not functioning or no alarm (12.2.7)	Orange	<input type="checkbox"/> Yes <input type="checkbox"/> No	
Gauges	not replaced or calibrated in 5 years, not accurate within 3% of scale (12.2.8.1 – 12.2.8.3)	Yellow	<input type="checkbox"/> Yes <input type="checkbox"/> No	
Control valve	Valve will not operate through its full range (12.3.3.1)	Orange	<input type="checkbox"/> Yes <input type="checkbox"/> No	
Control valve	No spring or Torsion felt in rod when opening post indicator valve (12.3.3.2)	Red	<input type="checkbox"/> Yes <input type="checkbox"/> No	
Supervisory switches	No signal from two revolutions of the hand wheel from normal position or when stem has moved 1/5 of the distance from normal position, signal restored in position other than normal (12.3.3.5.2)	Yellow	<input type="checkbox"/> Yes <input type="checkbox"/> No	
Preaction valve	Priming water level not correct (12.4.3.2.1)	Orange	<input type="checkbox"/> Yes <input type="checkbox"/> No	
Deluge valve	Annual full flow trip test revealed plugged nozzles, pressure reading at hydraulically most remote nozzle and/or at valve not comparable to original design values, manual actuation devices	Red	<input type="checkbox"/> Yes <input type="checkbox"/> No	

	did not operate properly (12.4.2.2.3)			
Preaction Valve	Low air pressure switch did not send signal or no alarm (12.4.3.2.10)	Yellow	<input type="checkbox"/> Yes <input type="checkbox"/> No	
Deluge valve	Low temperature switch did not send signal or and alarm (12.4.3.2.11)	Yellow	<input type="checkbox"/> Yes <input type="checkbox"/> No	
Preaction valve	Automatic air maintenance device did not pass test (12.4.3.2.12)	Yellow	<input type="checkbox"/> Yes <input type="checkbox"/> No	
Dry pipe valve	priming water level not correct (12.4.4.2.1)	Orange	<input type="checkbox"/> Yes <input type="checkbox"/> No	
Dry pipe valve	Annual trip test results were not comparable to previous tests (12.4.4.2.2)	Yellow	<input type="checkbox"/> Yes <input type="checkbox"/> No	
Dry pipe valve	no full flow trip test done after 3 years (12.4.4.2.2.2)	Yellow	<input type="checkbox"/> Yes <input type="checkbox"/> No	
Quick opening device	Quick opening device did not pass test (12.4.4.2.4.)	Orange	<input type="checkbox"/> Yes <input type="checkbox"/> No	
Dry pipe valve	Low air pressure switch did not send signal or no alarm (12.4.4.2.6)	Yellow	<input type="checkbox"/> Yes <input type="checkbox"/> No	
Dry pipe valve	Low temperature switch did not send signal or no alarm (12.4.4.2.7)	Yellow	<input type="checkbox"/> Yes <input type="checkbox"/> No	
Dry pipe valve	Automatic air maintenance device did not pass test (12.4.4.2.8)	Orange	<input type="checkbox"/> Yes <input type="checkbox"/> No	
Standpipe pressure reducing control valves	No full flow test done after 5 years or test results not comparable to previous results (12.5.1.2)	Yellow	<input type="checkbox"/> Yes <input type="checkbox"/> No	
Hose valves(Class I & Class III Standpipe system)	Annual test revealed valve leaking or difficult to operate (12.5.5.2.1.1)	Orange	<input type="checkbox"/> Yes <input type="checkbox"/> No	
Hose valves	Cap missing	Yellow	<input type="checkbox"/> Yes <input type="checkbox"/> No	
Hose valves	Thread damaged	Red	<input type="checkbox"/> Yes <input type="checkbox"/> No	
Hose valves	wheel handle broken or missing (not applied to NYCHA)	Orange	<input type="checkbox"/> Yes <input type="checkbox"/> No	
Backflow prevention assemblies	Did not pass forward flow test (12.6.2.1)	Red	<input type="checkbox"/> Yes <input type="checkbox"/> No	
Backflow prevention assemblies	No forward flow test done after one year (12.6.2.1)	Yellow	<input type="checkbox"/> Yes <input type="checkbox"/> No	

PART 11: SIGNAGE REQUIREMENTS

All **interior** signage shall have a **red background** with minimum 1 inch high **white letters**. All **exterior** signage shall have a **white background** with minimum 1 inch high **red letters**. (NYC Building Code and NYC FD Code)

11.1 Fire Department connection sign

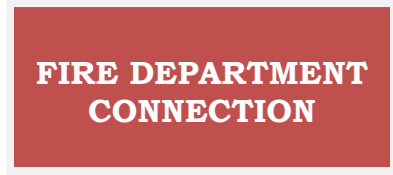

11.2 Control valve sign



11.3 Stand Pipe System Shutoff sign



11.4 Fire Department connections serving a standpipe system sign

Fire Department connections servicing a standpipe system shall be provide with caps painted red, and shall have word



11.4 Standpipe systems type sign



11.5 Supply Hose sign

Hose marked "SUPPLY HOSE" shall not be used at operating pressures exceeding 185 psi



11.6 Stairways without hose connections sign

Stairways without hose connections shall have a sign on the door to the stairway stating.



11.7 Fire Hose sign

If the hoses are installed in cabinets each cabinet should be labeled:



11.8 On dry standpipe with no permanent water Supply sign

This system is usually used in a building that is not heated such as unoccupied buildings and parking garage structures. On this system a sign must be attached to each of the hose outlets. It should read:



PART 12: NYC Building LOCAL LAW 58 OF 2009



STANDPIPES + SPRINKLERS New Safety Regulations

New standpipe and sprinkler piping laws go into effect in 2010. Building owners and contractors must be sure their properties and projects comply with these new local laws.

The Buildings Department participated in the multi-agency advisory group that proposed these new safety standards. Mayor Michael R. Bloomberg appointed Deputy Mayor Edward Skyler to lead the Construction, Demolition and Abatement Working Group, which generated 33 safety recommendations – including the four local laws described here.

To learn more, read *Strengthening the Safety, Oversight and Coordination of Construction, Demolition and Abatement Operations*, available at nyc.gov/buildings.

CUTTING AND CAPPING Local Law 60/09, effective 3/2/2010.

Permits are required to cut and cap standpipes or sprinklers.

- Authorized Licensees: Only licensed master plumbers or licensed master fire suppression piping contractors may cut and cap standpipes or sprinklers during demolition.
- Local Law Incorporates TPPN 3/07: For demolitions and gut rehabilitations, a registered design professional must have a variance to remove damaged or inoperable sprinklers. This filing must include a damage report and explanation why the system can't be restored. (The design professional must first file the variance with the Fire Department and have FDNY approval before filing it with the Buildings Department.)

COLOR CODING

Local Law 58/09, effective 3/2/2010.

Existing buildings must comply by 6/2/2010.

All exposed standpipes and sprinkler piping must be painted red. The law outlines specific exceptions, such as branch piping.

All buildings – no matter the size or occupancy – must comply with these new requirements.

Dedicated standpipe valve handles must be painted **red**.



Combination standpipe valve handles must be painted **yellow**.



Dedicated sprinkler valve handles must be painted **green**.



COLOR CODING CERTIFICATION

Buildings Under Construction

The special inspector will confirm compliance before the walls are enclosed.

Existing Buildings

Owners of buildings with exposed sprinkler piping and standpipes must comply and hire one of four types of contractors to certify the color coding:

- Licensed master plumbers;
- Licensed master fire suppression piping contractors;
- Registered design professionals; or
- People with the appropriate Fire Department Certificate of Fitness.

PROOF OF COLOR CODING CERTIFICATION

The color coding certification must be kept on the premises at all times for Buildings and Fire Department inspection. Visit nyc.gov/buildings for the certification form, available online in March 2010. (over)



Robert D. LiMandri, Commissioner

Michael R. Bloomberg, Mayor

Exception: Where a standpipe system is used as a combination standpipe and sprinkler system, the sprinkler risers and cross connections that are also used for the standpipe system shall be painted red and the handles of valves serving such combination system shall be painted yellow.

Fire Suppression Piping Components to be identified as required by Local 58/2009

NOTE: Only existing visible piping shall be identified as required. When ceilings are removed during renovations, any existing visible system piping shall be identified and painted.

Standpipe Feed Mains - The portion of the standpipe system piping that supplies water to one or more standpipe.

Standpipe and Sprinkler Cross Connections - The portion of the standpipe or sprinkler system that interconnects the feed mains and risers to the fire department connections.

Standpipe and Sprinkler Risers - The vertical portion of the system piping that delivers the water supply for hose connections, and sprinklers on stand alone as well as combined systems, vertically from floor to floor.

Fire Department Connections - The portion of the standpipe system that is connected to the fire department pumper connection and supplies the standpipe and sprinkler feed mains, cross connections, and risers. The Fire Department connection caps for a standpipe system shall be painted red.

All handles of Indicating Valves - These handles control controlling the water supplies to the standpipe and sprinkler systems.

Street water supply - The portion of system piping connected to the discharge of the water meter to the main standpipe control valves.

Exposed cross connections and riser piping must be painted in accordance with Buildings Bulletin 2010-014.

All pipe material identification information, if present, shall not be painted.

Fire Suppression Piping Components not required to be identified as required by Local 58/2009.

Fire Department Hose valve bodies and handles, indicating control valve bodies, check valves, jockey pump control valves, trim, test, and drain valve handles.

Standpipe Branch Piping - The portion of the piping system connecting one or more hose valve stations.

Sprinkler Cross Mains - The portion of the piping system connecting supplying the branch lines either directly or through risers.

Sprinkler Feed Mains - The portion of the piping system downstream of a sectional or floor control valve supplying cross mains.

Sprinkler Branch Piping - The portion of the piping system to which the sprinkler heads or nozzles are directly connected to.

For more info go to the attached URL (NYC Building website Local law 58/2009)<http://www.nyc.gov/html/dob/downloads/pdf/l158of2009.pdf>

LOCAL LAWS #58/2009

903.6 Painting of dedicated sprinklers. *Dedicated sprinkler piping shall be painted and such painting certified in accordance with Sections 903.6.1 through 903.6.5. In addition to painting, sprinkler piping may also be identified by lettered legend in accordance with ANSI A13.1. Where the piping is required to be listed and labeled such painting shall not obscure such labeling.*

Exceptions:

1. Attachments, gauges, valves and operable parts of sprinkler systems other than valve handles.
2. Horizontal branch lines.
3. Where different color coding may be required by Section 3406 of the New York City Fire Code for facilities storing, handling, and using flammable and combustible liquids in connection with special operations.

903.6.1 New buildings. Cross connections and risers *in new buildings, including buildings constructed pursuant to Section 28-101.4.2 of the Administrative Code, shall be painted **red** and **the handles of valves** serving sprinklers shall be painted **green** prior to the hydrostatic pressure test regardless of whether they will be enclosed at a later point in time.*

Exception: *Where a standpipe system is used as a combination standpipe and sprinkler system, the sprinkler risers and cross connections that are also used for the standpipe system shall be painted **red** and the handles of valves serving such combination system shall be painted **yellow**.*

903.6.2 Alterations. *Cross connections and risers for independent (stand-alone) existing sprinkler systems that are exposed during alterations, including alterations pursuant to Section 28-101.4.2 of the Administrative Code, shall be painted red and the handles of valves serving such existing sprinkler systems shall be painted green. Where the alteration requires a hydrostatic pressure test such painting shall be completed prior to such test.*

Exception: *Where a standpipe system is used as a combination standpipe and sprinkler system, the sprinkler risers and cross connections that are also used for the standpipe system shall be painted **red** and the handles of valves serving such combination system shall be painted **yellow**.*

903.6.3 Retroactive requirement for completed buildings. *Notwithstanding any other provision of law, all exposed risers and cross connections of completed buildings in existence on the effective date of this section shall be painted red within three months after the effective date of this section, and all handles of valves serving such sprinkler system shall be painted green.*

Exception: *Where a standpipe system is used as a combination standpipe and sprinkler system, the sprinkler risers and cross connections that are also used for the standpipe system shall be painted red and the handles of valves serving such combination system shall be painted yellow.*

903.6.4 Buildings under construction on the effective date of this section. *Notwithstanding any other provision of law, where construction documents were*

*approved and permits issued for the construction of a new building or alteration of an existing building prior to the effective date of this section and the work is not signed off by the department prior to such date, all exposed cross connections and risers in any such building shall be painted red prior to the hydrostatic pressure test, including cross connections and risers that will be enclosed at a later point in time, and handles of valves serving such sprinkler system shall be painted **green**.*

Exceptions:

- 1. Where a standpipe system is used as a combination standpipe and sprinkler system, the sprinkler risers and cross connections that are also used for the standpipe system shall be painted red and the handles of valves serving such combination system shall be painted yellow.*
- 2. Cross connections and risers enclosed prior to the effective date of this section need not be painted.*

903.6.5 Certification of completion of system painting. *For all buildings where sprinkler and combination sprinkler and standpipe systems are not subject to a special inspection pursuant to Section 1704.21 of this code, a licensed master plumber, licensed master fire suppression piping contractor, registered design professional or an individual holding an appropriate C of F from the Fire Department for the operation and/or maintenance of such system shall certify on forms provided by the department that all required painting has been completed in accordance with Section 903.6. Such certification shall be maintained on the premises and made available for inspection by the department and the Fire Department.*

§2. Section 905 of the New York city building code, as added by local law number 33 for year 2007, is amended by adding a new section 905.11 to read as follows:

905.11.6 Certification of completion of system painting. *For all buildings where standpipe and combination sprinkler and standpipe systems are not subject to a special inspection pursuant to Section 1704.22 of this code, a licensed master plumber, licensed master fire suppression piping contractor, registered design professional or an individual holding an appropriate C of F from the Fire Department for the operation and/or maintenance of such system shall certify on forms provided by the department that all required painting has been completed in accordance with Section 905.11. Such certification shall be maintained on the premises and made available for inspection by the department and the Fire Department.*

PART 13: Fire Department Code and Rules Chapter 9

13.1 Fire Department Code Section 905 Standpipe System

SECTION FC 905 STANDPIPE SYSTEMS

905.1 General. Standpipe systems shall be provided where required by the construction codes, including the Building Code, this code or the rules. Fire hose threads used in connection with standpipe systems shall be approved by the commissioner. The location of fire department hose connections shall be approved by the commissioner. Standpipe systems in buildings used for high-piled combustible storage shall be in accordance with Chapter 23.

905.1.1 Standpipe system operator. In buildings with a multi-zone standpipe system, such system shall be **continuously under the personal supervision** of a person holding a C of F, who shall be immediately available to assist the department in the operation of such system.

905.2 Installation standards. Standpipe systems shall be installed in accordance with the construction codes, including the Building Code.

905.7 Cabinets. Cabinets containing firefighting equipment, such as standpipes, fire hose, portable fire extinguishers and water supply control valves, shall not be obstructed from use or obscured from view.

905.8 Reserved.

905.9 Valve supervision. Valves controlling water supplies shall be supervised in the open position so that a change in the normal position of the valve will generate a supervisory signal at the central station required by Section 903.4. Where a fire alarm system is provided, a signal shall also be transmitted to the fire alarm system control panel.

Exceptions:

1. Valves to underground key or hub valves in roadway boxes provided by the municipality or public utility do not require supervision.
2. Valves locked in the normal position and inspected as provided in this code in buildings not equipped with a fire alarm system.

905.10 During construction. Standpipe systems required during construction, alteration and demolition operations shall be provided in accordance with Chapter 33 of the Building Code and Section 1413.

905.11 Reserved.

905.12 Maintenance. Standpipe systems shall be maintained, including all required inspection, testing and servicing, in accordance with this section, Section 901.6 and NFPA 25.

905.12.1 Standpipe hydrostatic pressure and flow tests. Upon order of the commissioner, but at least once every 5 years, the standpipe system shall be subjected to a hydrostatic pressure test and a flow test to demonstrate its suitability for department use. These tests shall be conducted in compliance with the requirements

of the rules and shall be conducted at the owner's risk, by his or her representative before a representative of the department.

905.12.2 Pressure reducing valves. Upon order of the commissioner, but at least once every 3 years, standpipe systems with pressure reducing valves installed shall be flow tested to demonstrate proper adjustment of such valves. (Suppression unit)

13.2 Fire Department Rules § 905-01 Standpipe System

§ 905-01 Standpipe System Pressure Reducing Devices

- (a) **Scope.** This section sets forth requirements for *standpipe system* pressure reducing devices.
- (b) **Definitions.** The following terms shall, for purposes of this section and used elsewhere in the *rules*, have the meanings shown herein:
Pressure reducing devices. Devices, including valves, installed in *standpipe systems* at or near hose outlet connections that act to limit both the static and dynamic water pressures downstream of the standpipe outlet valve.
Pressure restrictors. Removable fittings or "SECO Type" valves that restrict flowing water pressures by reducing the available cross-sectional area of flow.
- (c) **General Provisions**
(1) Certificate of approval. *Pressure reducing devices* installed in a *standpipe system* shall be of an approved type and for which a *certificate of approval* has been issued.
- (d) **Pressure Reducing Device Requirements.**
(1) Location and pressure markings. Each *pressure reducing device* shall be permanently marked with the address of the *premises* in which it is installed, its floor location, and its designated pressure setting.
(2) Adjustments and reporting. Upon initial installation of a *pressure reducing device*, and at least once every three (3) years thereafter, a master fire suppression contractor shall file an affidavit with the *Department* on behalf of the building *owner* attesting to the following:
(A) The building address and *owner's* name.
(B) The floor location of all *standpipe system pressure reducing devices* and the inlet pressure (static and operating) of each device.
(C) The setting of each device and the corresponding discharge flow rate (*gpm*), discharge pressure (*psig*), and the maximum outlet static pressure (*psig*).
(D) The name, address, and master fire suppression contractor license number of the person submitting the affidavit.
(3) **Flow testing.** Upon order of the *Commissioner*, but at least once every three (3) years, *standpipe systems* with *pressure reducing devices* installed shall be flow tested with a minimum actual flowing discharge of 250 *gpm*. These tests shall be conducted by a master fire suppression contractor who shall provide the *Department* five (5) business days notice of the date and time of the test. The *Department* may witness these tests at its discretion.