

RESIDENTIAL REQUIREMENTS

CHAPTER 4

RESIDENTIAL ENERGY EFFICIENCY

2011 New York City Energy Conservation Code

Effective December 28, 2010



The New York City Department of Buildings wishes to acknowledge the generous grant from the United States Department of Energy under the American Recovery and Reinvestment Act, enacted by President Obama and Congress in 2009. This grant funded the creation of these training modules; without this support, these materials would not have been possible.

We also wish to acknowledge the support of Mayor Bloomberg and the New York City Council who created PlaNYC 2030, with a goal of reducing New York City's carbon emissions by 30% by 2030, from 2005 levels.

© 2011 City of New York. All rights reserved.

Permission is granted for the noncommercial use and reproduction of this presentation, without alteration, for educational purposes.

This training module was developed by:

Viridian | Energy &
Environmental, LLC

Welcome to the New York City Department of Buildings Energy Code Training Modules!

This RESIDENTIAL Module Addresses:

- ❑ General Code requirements and applicability for residential projects
- ❑ Technical requirements and strategies related to all aspects of residential energy efficiency, including the thermal envelope, electrical and mechanical provisions of the 2011 NYCECC
- ❑ NYC DOB Energy Code Submission and Progress Inspection Requirements for residential buildings

This module addresses Energy Code requirements related to all low rise single family and multifamily residential buildings, when 3 or less stories. Residential Energy Code also covers Group R Buildings that are 3 stories and lower.

Energy criteria related to R-2 and R-3 occupancies four stories and higher are covered under the NYC DOB Commercial Building Training Modules.

- The **RESIDENTIAL** Module has been divided into a number of smaller sub-topics. These can be accessed either in-sequence or out-of-sequence through links in the main “Menu” slide.
- Each sub-topic begins with a brief overview of the issues to be reviewed, and many end with a set of summary questions or exercises.
- Many of the sub-topics are organized in a Q & A format. Code-related questions are posed at the top of a slide, with answers provided below, or in the following sequence of slides.



The **NYC Buildings** logo takes you to the NYCECC 2011 Training Modules home page.



The **Menu** icon takes you to the main menu page within each module.



The **Attention** icon brings up Callouts with key points and additional information.



The **Links** icon takes you to related DOB web pages or other resources.



The **Documentation** icon addresses DOB documentation issues and requirements.



The **Inspection** icon addresses DOB Progress Inspection issues and requirements.



The **Code Reference** icon refers to relevant Code sections.





The **NYC Buildings** logo takes you to the NYCECC 2011 Training Modules home page.



The **Menu** icon takes you to the main menu page within each module.



The **Attention** icon brings up Callouts with key points and additional information.



The **Links** icon takes you

The slides are enhanced with special icons that will help to focus on key points, or serve as links to external resources. The Attention icon brings up Callouts (like this one) with key points and additional information.



The **Documentation** icon add



The **Inspection** icon addresses DOB Progress Inspection issues and requirements.



The **Code Reference** icon refers to relevant Code sections.



1. What's New in the 2011 NYCECC	Key Updates to Residential Sections • Current Local Laws, Rules & Bulletins	8
2. Code Applicability	DOB Terminology • Applicability by Building Types	13
3. Key Thermal Properties	R-Value • U-Factor • Insulation Materials • Thermal Boundary • Thermal Bridging	21
4. Thermal Requirements	Wood Walls • Steel Walls • Mass Walls • Attics • Crawl Space Walls Basement Walls • Slabs • Floors • Fenestration & Windows • Sun Rooms	34
5. Air & Moisture Control	Air Barriers & Vapor Retarder • Air Sealing • Testing • Recommended practices	58
6. M / E / P Systems	Mechanical Systems • Snow & Ice Melt • Swimming Pools • Lighting Systems Electrical Requirements	68
7. Submissions & Inspections	Energy Analysis • Supporting Documentation • Progress Inspections	84
8. Resources	References and Resources • DoB Assistance	112



1. What's New in the 2011 NYCECC	Key Updates to Residential Sections • Current Local Laws, Rules & Bulletins	8
2. Code Applicability	DOB Terminology • Applicability by Building Types	13
3. Key Thermal Properties	R-Value • U-Factor • Insulation Materials • Thermal Boundary • Thermal Bridging	21
4. Thermal Requirements	Wood Walls • Steel Walls • Mass Walls • Attics • Crawl Space Walls Basement Walls • Slabs • Floors • Fenestration & Windows • Sun Rooms	34
5. Air & Moisture	Air Barriers & Vapor Retarder • Air Sealing • Testing • Recommended practices	58
6.	Swimming Pools • Lighting Systems	68
7.	ation • Progress Inspections	84
8. Resources	References and Resources • DoB Assistance	112

The main menu slide is interactive; clicking on each line item will take you to the respective sub-module. Use this feature to navigate throughout the presentation. The menu icon at the bottom right corner of each slide will always bring the you back to the main menu slide.



In this section you will learn about:

- ❑ Key changes and additions in the 2011 NYCECC related to residential buildings, including the building envelope, HVAC, service hot water and electrical;
- ❑ Current NYC Local Laws affecting Energy Code compliance; and
- ❑ Current Rules and Bulletins affecting Energy Code compliance.

Simplified, Streamlined & More Comprehensive

- ❑ Detached one- and two-family homes, and multiple dwellings three stories or less have to follow residential energy efficiency requirements (Includes R-2 & R-3)
- ❑ Thermal requirements have been modified:
 - ▶ Window (whole assembly) values are more stringent (lower U-Factor)
 - ▶ Wood-framed wall insulation values have decreased
 - ▶ Mass wall structures have an added option for interior insulation placement
 - ▶ Steel framed walls have a continuous insulation scenario under prescriptive option
- ❑ Envelope Trade-Offs with high-efficiency HVAC equipment no longer allowed
- ❑ Electric resistance heat criteria have been eliminated
- ❑ Special requirements added for siding attachment over foam sheathing
- ❑ Detailed requirements for ceilings with unvented attics have been added



Simplified, Streamlined & More Comprehensive

- ❑ Air leakage requirements are expanded
 - ▶ Includes limitations for opaque elements & fenestration, continuous air barriers, requirements for air impermeable insulation, recessed light fixtures
- ❑ Vapor retarders & moisture control requirements are not mandated for NYC Boroughs (Climate Zone 4A).
 - ▶ Refer NYC Building Code for vapor retarder requirements
- ❑ HVAC Equipment sizing rules to be based on ACCA Manual J or Residential Code of NYS
 - ▶ Mechanical equipment high-efficiency trade-off option with less efficient envelope is no longer available
- ❑ Duct system must be tested; air leakage must be below NYCECC threshold
- ❑ Requirements for swimming pools and snow-melt systems added
- ❑ New lamp efficiency requirements added within homes & dwelling units
- ❑ Electrical metering for each dwelling unit is required







Local Laws

- LL1-2011 – Established the current 2011 NYCECC

Rules

- 1 RCNY §5000-01 
 - ▶ Energy Code submission procedures , including progress inspections in drawings
- 1 RCNY §101-07 
 - ▶ Qualification requirements for individuals performing progress inspections

Bulletins

- Buildings Bulletins 2010–031, 2010-032, 2011-015 
 - ▶ Provide interpretations of Energy Code applicability to HVAC, service water, lighting, electrical power, and envelope systems in additions, alterations, renovations, or repairs



Photo: Comstock / Jupiter Images

In this section you will learn about:

- ❑ DOB terminology related to NYCECC applicability;
- ❑ Differences in applicability for New Construction, Additions, Alterations, Renovations, and Repairs; and
- ❑ Allowable Exemptions and Exceptions.

The Code:

- ❑ The NYCECC is law.
- ❑ It applies to all buildings, new and existing, unless explicitly stated otherwise.

Rules:

- ❑ Rules are prepared by the DOB to implement the Code.
- ❑ Rules must go through a formal administrative public comment process.
- ❑ Rules have the force of law.

Bulletins:

- ❑ Bulletins are issued by the DOB, in part to clarify interpretations of the Codes.
- ❑ They may change more frequently than laws or rules.

The Code:

- ❑ The NYCECC is law.
- ❑ It applies to all buildings, new and existing, unless explicitly stated otherwise.

Rules:

- ❑ Rules are prepared by the DOB to implement the Code.
- ❑ Rules must go through a formal administrative public comment process.
- ❑ Rules have the force of law.

Bulletins:

- ❑ Bulletins are issued by the DOB, in part to clarify interpretations of the Codes.
- ❑ They may change more frequently.

The DOB website is always updated to reflect all changes to laws, rules and bulletins. Check the website frequently.

Exemptions:

- ❑ Exemptions define specific building types or building elements that are not required to meet the Code and are claimed on the PW1 form.
- ❑ The following are the only allowed exemptions to the NYCECC:
 - ▶ Historic buildings (per NYCECC 101.4.2, LL1 of 2011, §5000-01)
 - » National- or State-designated historic buildings
 - » Buildings certified as contributing buildings within a National- or State-historic district
 - » Buildings certified as eligible for the designations above
 - » City level certification does not qualify for exemptions
 - ▶ The envelopes of unconditioned or “low-energy” buildings or spaces (Low energy is <3.4 BTU/H or 1 Watt/SF peak design rate for space conditioning)
 - ▶ Temporary buildings under BC §3203 and §28-111
 - ▶ The following work types, which are categorized as not affecting energy use:
 - » FA (Fire Alarm), FP (fire suppression in a range hood), SD (standpipe), SP (sprinklers), FS (fuel storage), EQ (construction equipment), CC (curb cut), OT/BPP (Builder’s Pavement Plan), OT/FPP (Fire Protection Plan)



Exceptions:

- ❑ Exceptions are conditions under which specific provisions of the Code may not be required
- ❑ Exceptions to **Section NYCECC 101.4.3, Alterations**, apply only if they do not result in increased energy use of the building
 - ▶ There are 8 exceptions in this section
 - ▶ 6 of these exceptions apply to building envelope, which may impact residential projects
 - » See the **Building Envelope Requirements** module in this DOB NYCECC training series for a review of the 6 exceptions
- ❑ Additional exceptions exist within the specific provisions of the NYCECC, Chapter 4

2. Code Applicability

New Buildings

- ❑ All must comply via Prescriptive or Performance-Based Approaches (see topic 3 of this module)
- ❑ Only exemption is for envelope in low-energy/unconditioned buildings

Additions

- ❑ Must comply either:
 - ▶ As a stand-alone addition, or
 - ▶ Along with the existing building as a single entity

Alterations / Renovations

- ❑ Only applies to scope of alteration work; unaltered portions are not required to comply
- ❑ Some exceptions may apply (per Bulletins)

Repairs

- ❑ Technically applies even if a permit is not required (e.g., window or roof replacements or repairs)

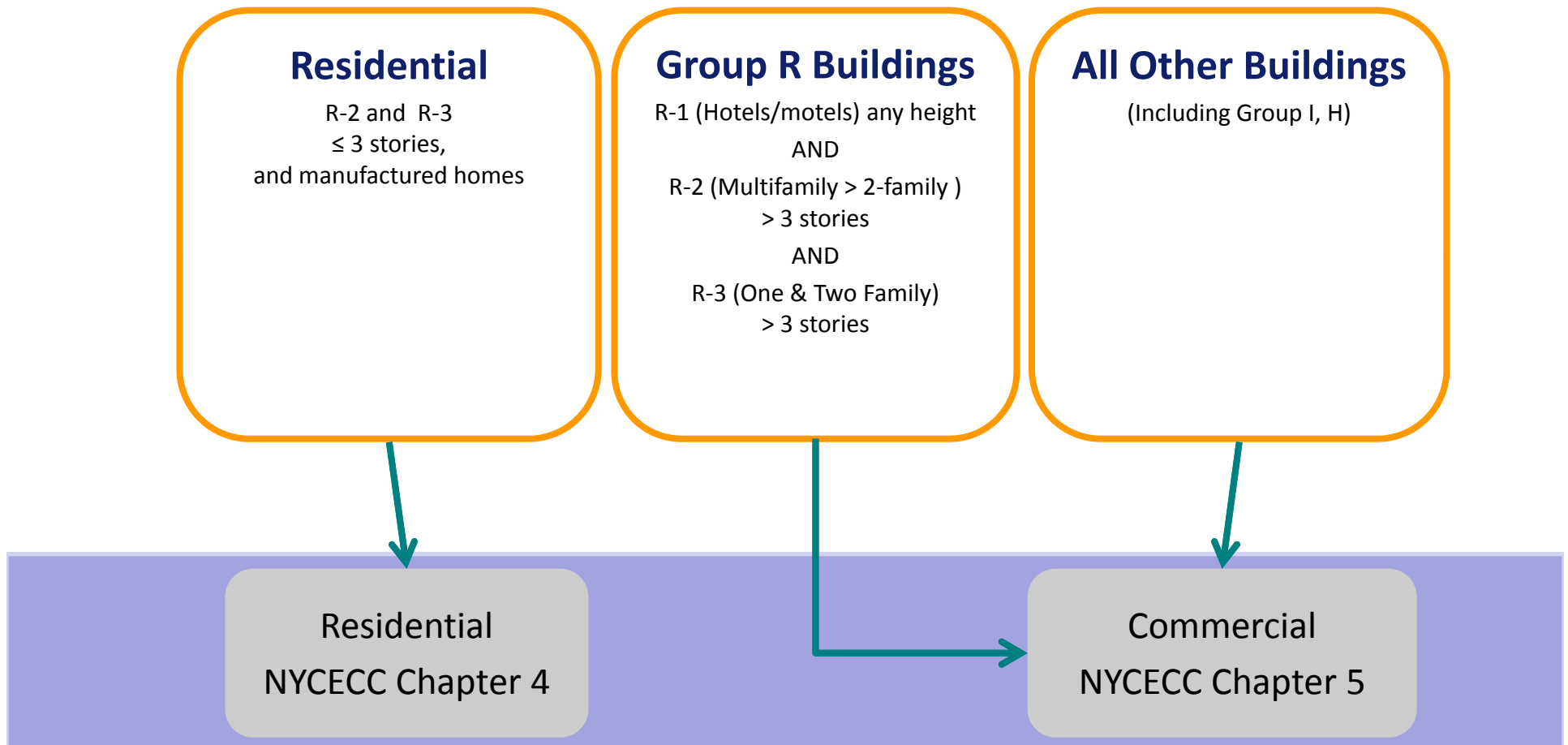

2. Code Applicability

Residential Building

- ❑ Detached 1- and 2-family dwellings, multiple single family dwellings (town houses) not more than 3 stories in height above grade
- ❑ Manufactured homes
- ❑ R-2 and R-3 that are 3 stories or less

Dwelling Unit

- ❑ Single unit providing complete independent living facilities for one or more persons, including permanent provisions for living, sleeping, eating, cooking & sanitation

Building Thermal Envelope (also called Thermal Boundary)

- ❑ The plane of the exterior envelope that physically separates conditioned space from the unconditioned exterior or unconditioned space.
- ❑ The thermal boundary must be continuous and closed, and insulated per NYCECC requirements. Air and moisture barriers must be maintained to protect the integrity of the thermal boundary.





In this section you will learn about:

- ❑ Key terminology used in describing the thermal properties of materials and assemblies, including R-Value & U-Factor;
- ❑ The R-Values of typical insulation materials, and how to verify R-Values in the field; and
- ❑ The differences between continuous and cavity insulation, concept of thermal boundary & how thermal bridging impacts the effectiveness of insulations and assemblies.

R-Value

- ❑ Thermal Resistance to heat flow through conduction
- ❑ Typically used for insulation layers
- ❑ Unit: $\text{hr} \cdot \text{ft}^2 \cdot ^\circ\text{F} / \text{Btu}$

U-Factor

- ❑ Thermal Transmittance to heat flow through conduction
- ❑ Typically used for all assemblies except below grade walls & slabs on grade
- ❑ Includes effect of exterior and interior air films
- ❑ Unit: $\text{Btu} / \text{hr} \cdot \text{ft}^2 \cdot ^\circ\text{F}$

Example: Heat Transfer through Conduction

- ❑ 100 sf. Envelope Surface
- ❑ Outside 0°F , Inside 70°F , Delta T = 70°F
- ❑ Window: Typical U=0.35: lets in $100 \text{ sf} \times 70 \times 0.35 = 2450 \text{ Btu} / \text{Hr}$.
- ❑ Wall: Typical R-20 or U-0.05: lets in $100 \text{ sf} \times 70\text{F} \times 0.05 = 350 \text{ Btu} / \text{Hr}$.



R-Value (Thermal Resistance):

- ❑ Measures an individual material's thermal resistance to heat flow (through conduction process)

 Higher R-Value is Better

- ❑ R-Values can be added, but:
 - ▶ Only if materials are in series, and assuming there are no thermal bridging effects due to metal or concrete
- ❑ R-Values of insulation materials are used to demonstrate compliance using the Prescriptive Method

Batt Insulation

Fiberglass Batts	R-3.1 to R-4.3 / inch
Rock Wool Batts	R-3.2 to R-3.9 / inch
Cotton Batts	R-3.7 / inch



Photo: Courtesy of DOE/NREL

Rigid Foam Boards

Expanded Polystyrene	R-3.9 to R-4.2 / inch
Extruded Polystyrene	R-5.0 / inch
Polyisocyanurate	R-5.6 to R-7.0 / inch
Polyurethane	R-5.6 to R-7.0 / inch



Photo: Courtesy of DOE/NREL

Loose-Fill (Blown In)

Cellulose	R-3.1 to R-3.7 / inch
Fiberglass	R-2.2 to R-2.9 / inch
Fiberglass (Dense-Pack)	R-3.4 to R-4.2 / inch
Mineral Wool	R-2.2 to R-2.9 / inch



Photo: Courtesy of DOE/NREL

Spray-In Place

Polyurethane Foam	R-5.6 to R-6.2 / inch
Low Density Urethane Foam	R-3.6 to R-4.3 / inch
Magnesium Silicate Foam:	R-3.9 / inch
Wet-Spray Cellulose	R-2.9 to R-3.4 / inch
Spray-in Fiberglass	R-3.7 to R-3.8 / inch



Photo: Courtesy of DOE/NREL



Protection of Foundation Insulation

- ❑ Weather resistant permanent & protective cover required for rigid insulation applied to exterior basement walls, crawl space walls and slab on grade construction

Additional Good Practices

(not specifically required in the NYCECC)

- ❑ Before installation
 - ▶ Sunlight, moisture, wind, physical compression or damage can significantly degrade insulation performance - on site protection during construction should be checked by Progress Inspectors
- ❑ Once Installed
 - ▶ Protection with permanent material covers (finishes, air and moisture barriers)
 - ▶ Compression to be avoided when installed in assembly





R:

- ❑ R-Value of Insulation installed within the cavity between framing members

Rci:

- ❑ R-Value of continuous insulation uninterrupted by framing, most commonly installed exterior to framing
- ❑ Typically required in assemblies where thermal bridging is significant
- ❑ In Residential Chapter, continuous insulation is referenced via footnotes in tables

Examples:

- ❑ Roof (attic) - **R-38**: cavity only requirement
- ❑ Walls (mass) - **R-9.5ci**: continuous only requirement
- ❑ Walls (metal framed) - **R-13+R-7.5ci**: cavity + continuous

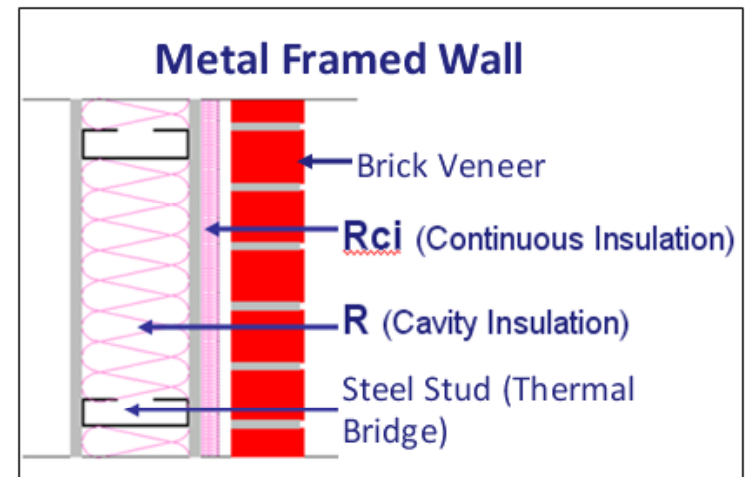

Insulation must be clearly & consistently indicated in drawings and all supporting documents. All "R" will be assumed to be cavity type unless "Rci" is used to denote continuous type.

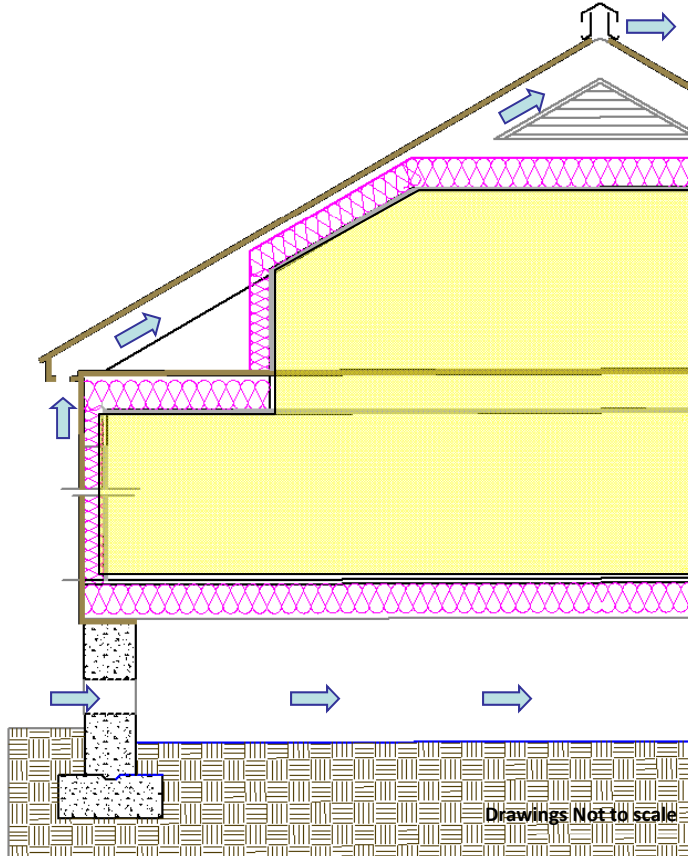

Figure 1. Vented Attic & Crawl Space

1. Attic & Crawl Space are outside building thermal envelope
2. Attic ceiling & Floor are insulated
3. Foundation wall need not be insulated

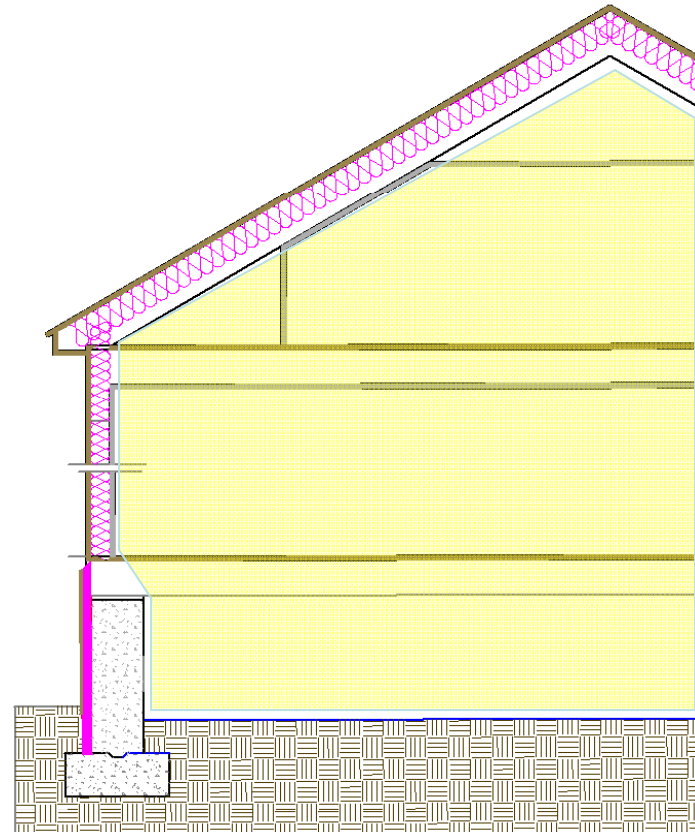

Figure 2. Unvented Attic & Crawl Space

1. Attic & Crawl Space are within building thermal envelope
2. Roof deck & Foundation Wall are insulated
3. Floor need not be insulated



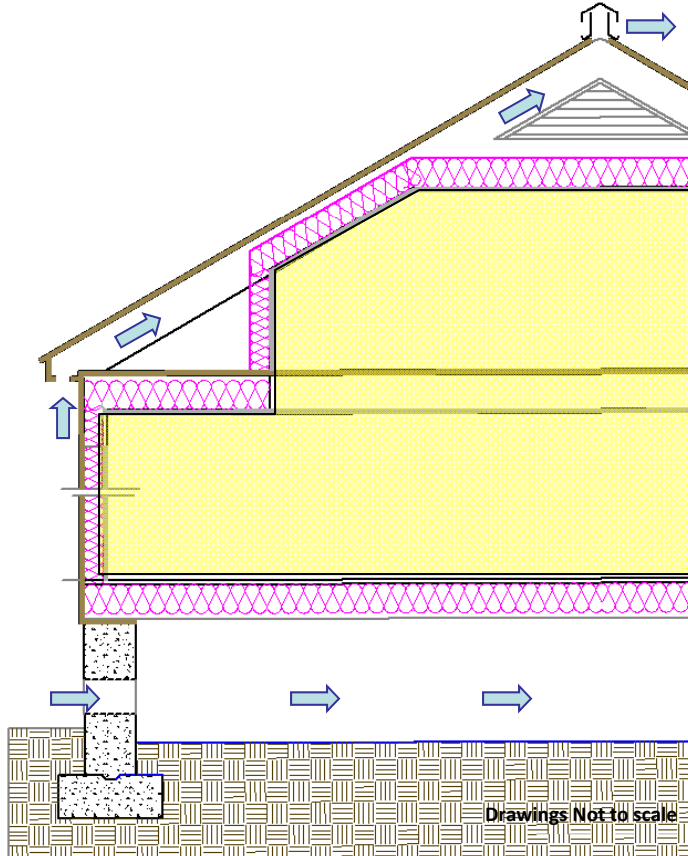

Figure 1. Vented Attic & Crawl Space

1. Attic & Crawl Space are outside building thermal envelope
2. Attic ceiling & Floor are insulated
3. Foundation wall need not be insulated

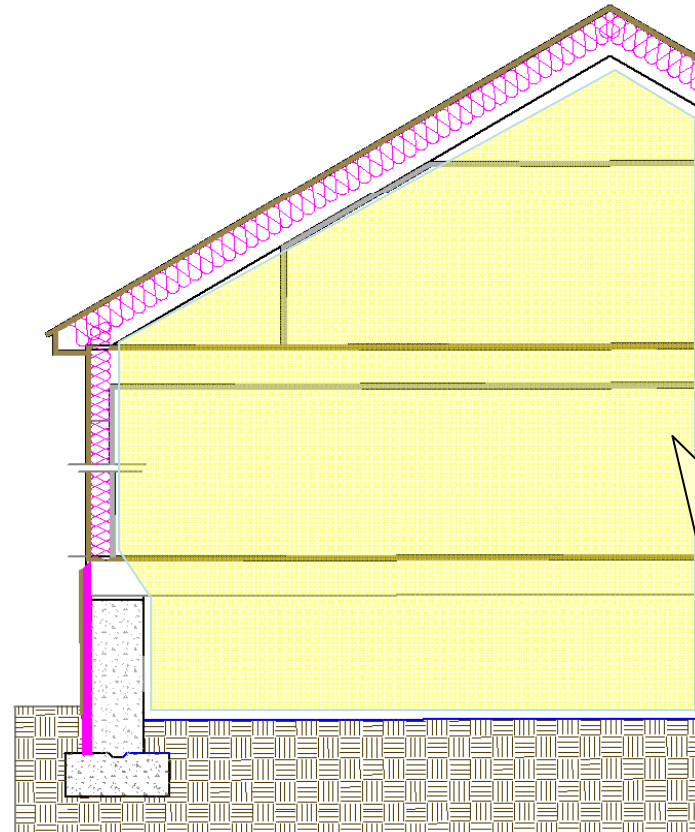

Figure 2. Unvented Attic & Crawl Space

1. Attic & Crawl Space are within building thermal envelope
2. Roof deck & Foundation Wall are insulated
3. Floor need not be insulated

Ensure continuity of insulation along the thermal boundary. Avoid gaps, unnecessary compression, penetrations or air leakage through insulation



Thermal bridging is caused by heat transfer through highly-conductive materials

- Typically steel or aluminum framing members are of most concern, but other materials can also create thermal short circuits

Examples @ cavity wall assembly:

- Nominal or Face Value of insulation
 - 3.5" Fiber glass insulation: R-13
 - 1" Rigid XPS: Rci-3.8
 - Other layers, R-2 approx. (Brick + Air Gap + Drywall + Air Films)
 - Total (Nominal) = R-18.2 (in figures 1 & 2)
- Actual value of insulation
 - Figure 1: In a Metal Framed wall, the effective value is R-12 (R-13 in cavity depreciates to R-7)
 - Figure 2: In a Wood Framed wall, the effective value is R-16 (R-13 in cavity depreciates R-10)

Figure 1. Metal Framed Wall

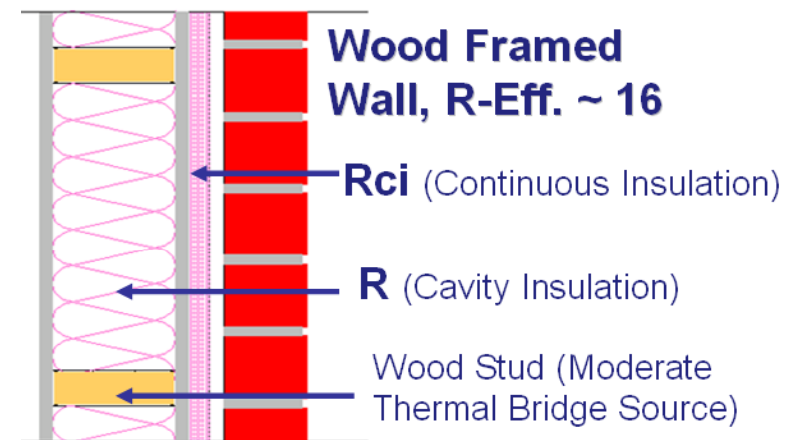
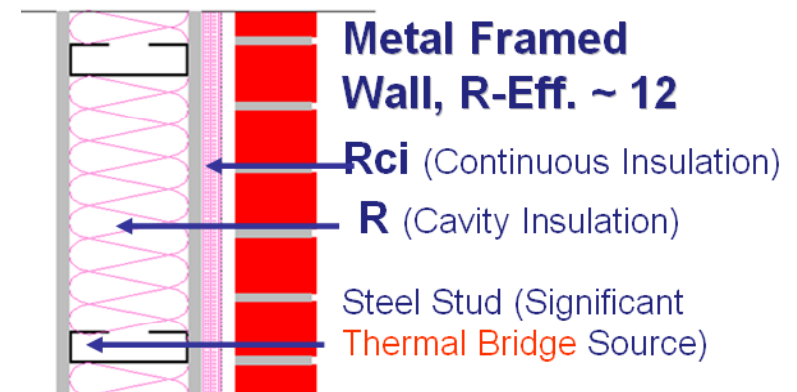

Figure 2. Wood Framed Wall

Progress inspection for documenting Insulation placement & R-Values

- Visual inspection required for installed insulation for each component of the conditioned space envelope & junctions between components. Confirm that:
 - ▶ R-Values are marked.
 - ▶ R-Values conform to those identified in the construction documents.
 - ▶ The insulation is properly installed.
 - ▶ Certifications for unmarked insulation shall be similarly visually inspected.
 - ▶ Certificate for blown or spray applied insulation required from insulation contractor.
 - ▶ Insulation markers to be installed for blown or spray applied roof / ceiling insulation.



Registered design professional or builder must provide a permanent certificate on or in the electrical panel. R-Values for insulation materials & U-Factors for windows, doors and skylights must be furnished in the certificate.



U-Factor – Thermal Transmittance

- ❑ Total Assembly’s Conductance (Btu/H.ft².F)
- ❑ Inverse of assembly’s R-Value

✔ Lower U-Value is Better

- ❑ Offers Flexibility for Trade-Offs
 - ▶ Trade-Offs are required if any of the prescriptive R-Values cannot be met.
- ❑ Accounts for thermal bridging – Effective R-Value for assembly
 - ▶ heat transfer occurring through framing members bypassing insulation.
- ❑ UA Alternative, Trade-off calculation must be used to demonstrate compliance based on Weighted Average Method

✘ Cannot add: (U1+U2+...)

Weighted Average Method for U

$$U = \frac{(U_1 \times A_1) + (U_2 \times A_2) + \dots}{A_1 + A_2 + \dots}$$

U₁ & U₂: U-Factor of each individual construction assembly. The assembly value must be computed using approved methods in ASHRAE (next slide).

A₁ & A₂: Corresponding surface area of the assembly as designed in the building.



Software Programs



- ❑ RESCheck or COMCheck
 - ▶ Also does an overall weighted average calculation among envelope elements
- ❑ HVAC Load analysis programs
 - ▶ Must be approved by Secretary of State of NYS and by the Commissioner of NYC Buildings
- ❑ DOE approved energy analysis programs
 - ▶ Energy Plus
 - ▶ eQUEST, DOE 2.1 E, Visual DOE

ASHRAE 90.1, Look Up Tables

- ❑ Appendix A-1

Manual Calculations

- ❑ Refer to ASHRAE Fundamentals textbook
 - ▶ Series Method
 - ▶ Parallel Path Method
 - ▶ Other methods are not approved for residential buildings

Software Programs

- ❑ RESCheck or COMCheck
 - ▶ Also does an overall weighted average calculation
- ❑ HVAC Load analysis programs
 - ▶ Must be approved by Secretary of State of NYS and by the Commissioner of NYC Buildings
- ❑ DOE approved energy analysis programs
 - ▶ Energy Plus
 - ▶ eQUEST, DOE 2.1 E, Visual DOE



REScheck is a free software program developed & distributed by the U.S. Department of Energy (DOE).

ASHRAE 90.1, Look Up Tables

- ❑ Appendix A-1

Manual Calculations

- ❑ Refer to ASHRAE Fundamentals textbook
 - ▶ Series Method
 - ▶ Parallel Path Method
 - ▶ Other methods are not approved for residential buildings



In this section you will learn about:

- ❑ How to determine insulation requirements using Prescriptive & U-Factor Alternative methods;
- ❑ Determining insulation requirements for different types of construction – wood frame, metal frame and mass walls; and
- ❑ Details for insulation placement and application for different envelope assemblies, including walls, floors, attics, basements, crawl spaces, windows & doors.

Method 1: Prescriptive R-Value

- Determine Min. R-Values for each component type using table 402.1.1 or 402.2.5 (Steel Framed Assembly) for Climate Zone-4
 - ▶ Each assembly must individually comply with the R-Value requirements (must be equal or higher)
 - ▶ The R-Value is nominal value, not impacted by framing
 - ▶ R-Values of non insulating materials are not considered

Method 2: U-Factor Alternative

- Determine Max. allowable equivalent U-Factors for each assembly type using table 402.1.3 for Climate Zone-4
 - ▶ Each assembly must individually comply with the U-Factor requirements (must be equal or lower)
 - ▶ The U-Factor is effective value, impacted by framing & non insulating materials



Residential Case Study Diagram

4. Insulation Requirements

? Identify Envelope Elements That are Required to be Insulated by Code.

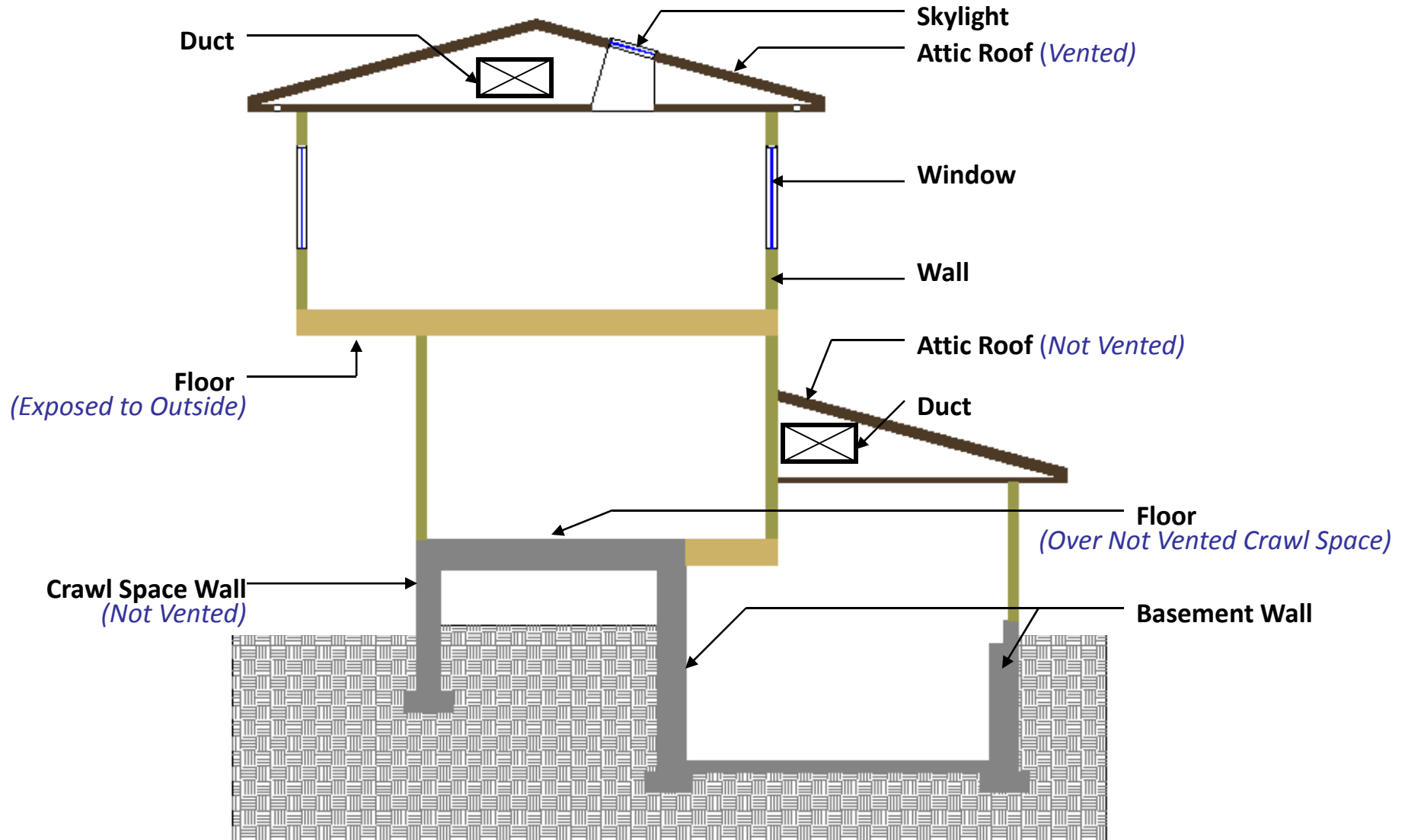

Compliance Requirements:

- Prescriptive R-Values
 - ▶ R-13 for walls (Refer to Table 402.1.1)
 - ▶ Insulation for walls, ceilings and floors are only required in cavity
 - ▶ Insulation for basement and crawl space walls (unvented) can either be installed on the interior cavity or in exterior using continuous rigid type insulation
- U-Factor alternative
 - ▶ Refer Table 402.1.3
 - ▶ U-0.082 is the maximum allowed for walls
 - ▶ Can be used for individual assemblies that differ from prescriptive requirements
 - ▶ Credit for non-insulating materials can be taken in this method

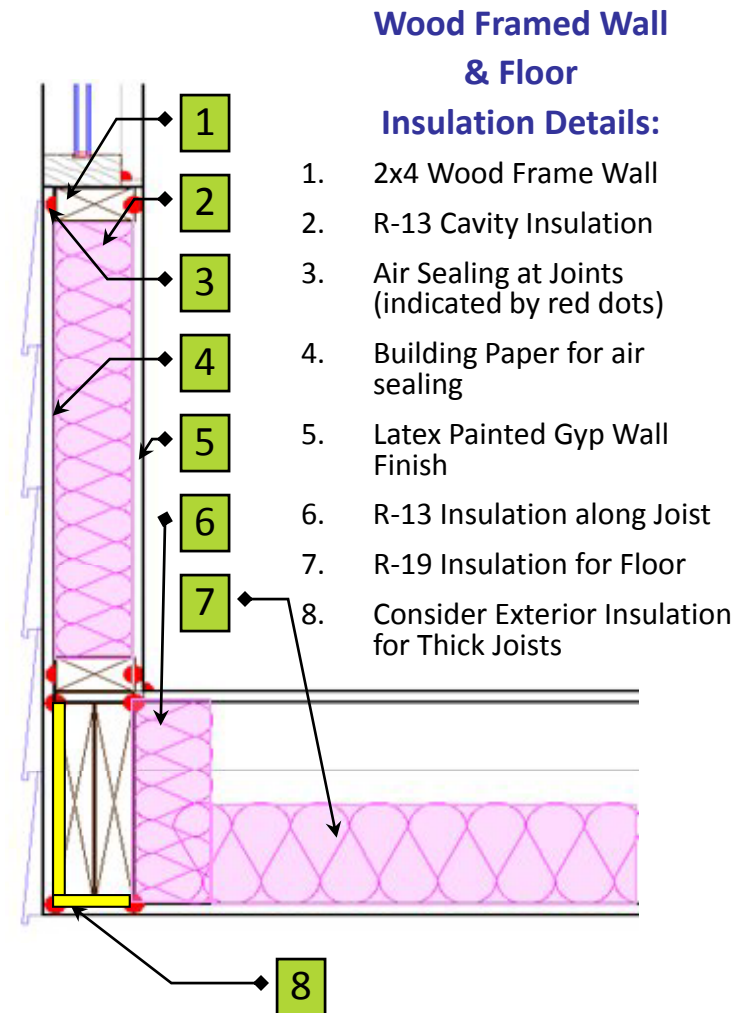

4. Insulation Requirements

? Identify Building Thermal Envelope & Minimum Insulation Requirements

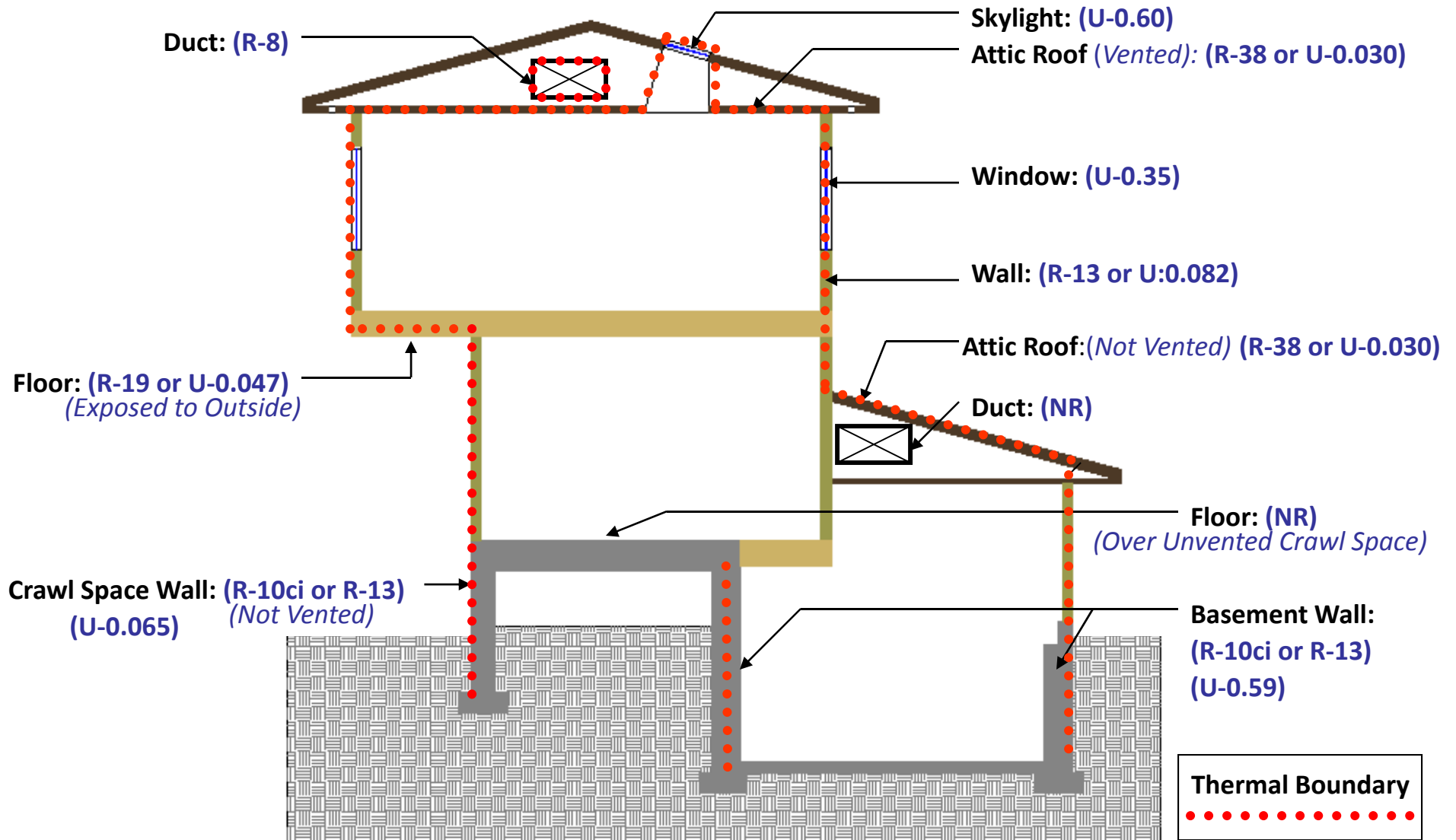

Compliance Requirements:

- Prescriptive R-Value
 - ▶ Table 402.2.5
 - ▶ Applies to steel truss ceiling, steel joist ceiling, steel framed wall & steel joist floor
 - ▶ Insulation requirements are higher than wood framed walls
 - ▶ A layer of continuous insulation is required in addition to or in lieu of cavity insulation to reduce thermal bridging
 - ▶ Wall Options (compared to R13 for wood):
 - » R13+Rci5, R15+Rci4, R21+Rci3, Rci10
- U-Factor alternative
 - ▶ Table 402.1.3
 - ▶ U-Factor calculation must follow **Series-Parallel Path** method
 - » See ASHRAE 90.1 Tables in Appendix A1

Steel Framed Wall & Joist Floor

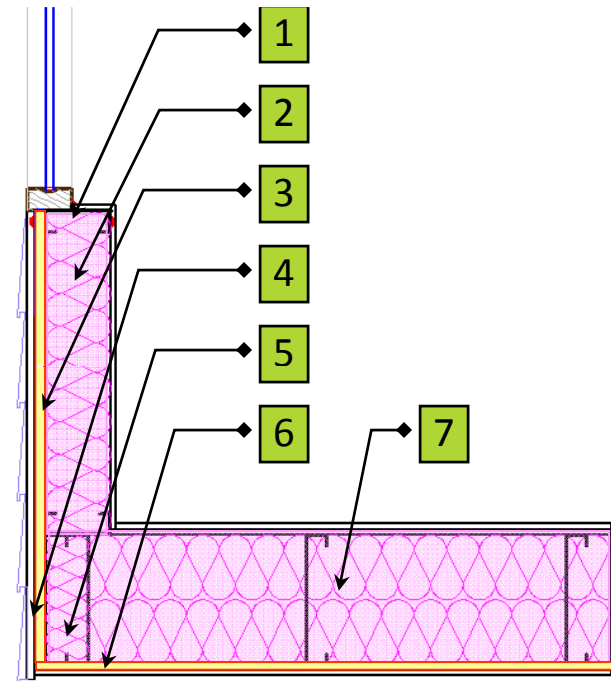

Insulation Details

1. 6" Steel Studs
2. R-13 Batt Insulation
3. R-5 Continuous Rigid Insulation
4. Rigid Insulation for continuity of thermal boundary
5. Insulation within joist framing cavity
6. Continuous Rigid Insulation
7. R-19 Batt Insulation



4. Insulation Requirements

? Determine Thermal Boundary & Minimum Insulation Requirements

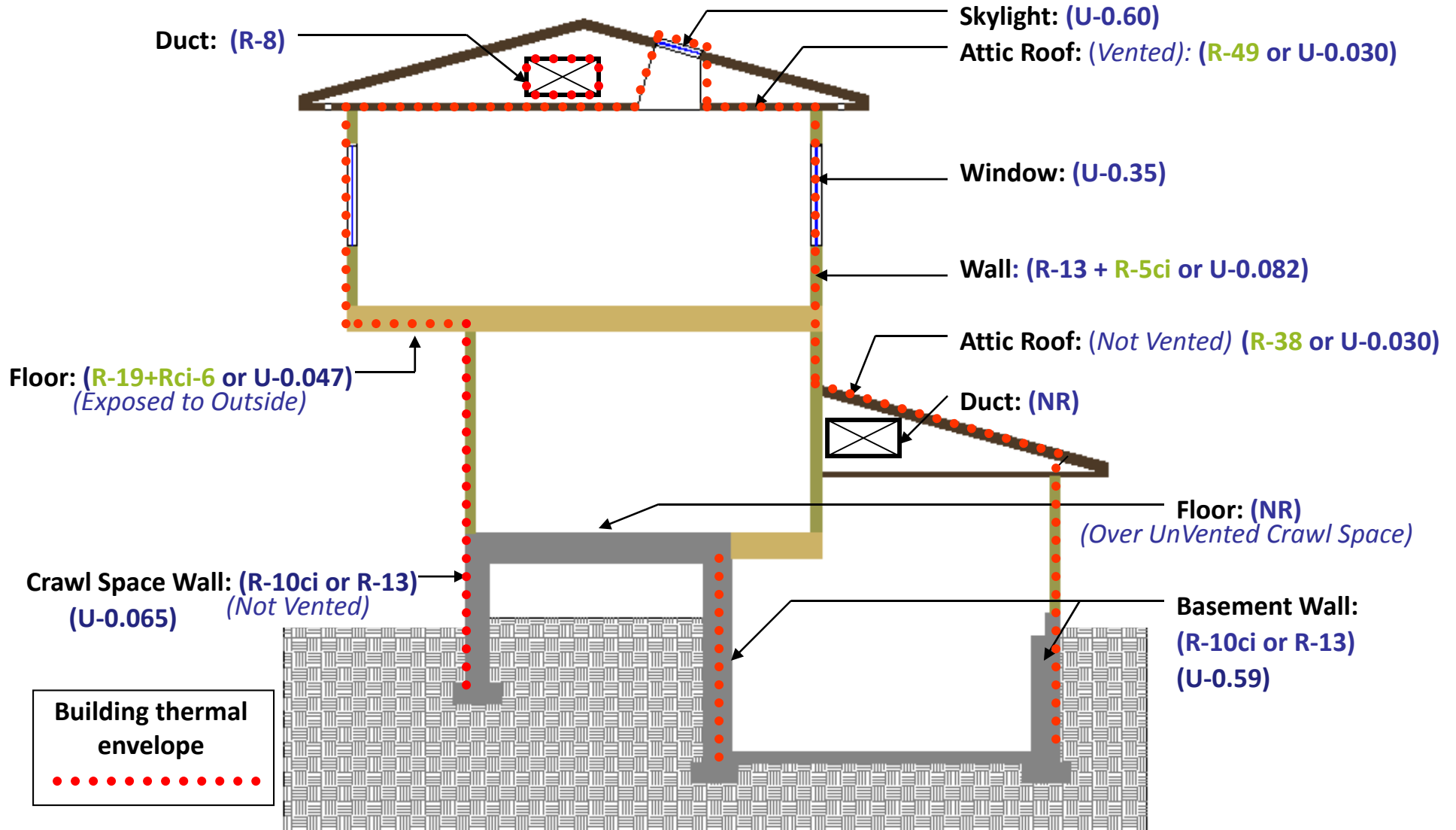

Applicable Wall Constructions

- ❑ Concrete Masonry Block (CMU)
- ❑ Concrete
- ❑ Insulated Concrete Forms (ICF)
- ❑ Masonry cavity
- ❑ Brick (excludes brick veneer)
- ❑ Earth (Adobe, Compressed Earth Block, Rammed Earth)
- ❑ Solid Timber / Logs

Insulation Requirements

- ❑ Insulation can be placed on outside or inside the thermal mass or split between the two
- ❑ Outside Placement:
 - ▶ More than 50% of insulation must be placed exterior to the mass.
 - ▶ Minimum required is R-10 total
 - ▶ Maximum allowed U-0.141
- ❑ Inside placement:
 - ▶ More than 50% of insulation must be placed interior to the mass.
 - ▶ Minimum required is R-13 total
 - ▶ Maximum allowed U-0.10



Photo: Courtesy of DOE/NREL



4. Insulation Requirements ? What are the Requirements for Siding Installed Over Foam Sheathing?

Siding Attachment Requirements over Foam Sheathing to Support Siding Weight:

- ❑ Accounts for wood & metal framed construction
- ❑ Direct Attachment & Offset Attachment scenarios are defined
 - ▶ Offset scenarios involve furring
- ❑ Fastener sizes and spacing limitations defined (vertical & horizontal)
- ❑ Different siding weights accounted for
- ❑ Applies if wind speed < 100 mph; higher wind speeds require custom design

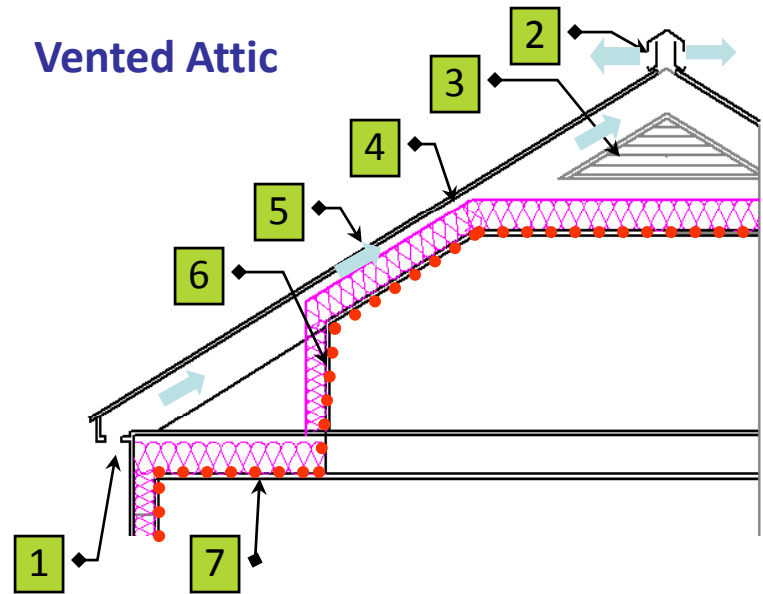

Photo: Courtesy of DOE/NREL



Construction Features:

- Vents are present at soffits & ridge to allow for air flow within attic
 - ▶ Soffit & ridge vents must be clear, adequate and evenly distributed for free & uniform flow of air
- Building thermal envelope occurs above the ceiling
 - ▶ Attic space is considered unconditioned
 - ▶ Roof deck is cold in winter
- Insulation must be installed over air tight ceiling
 - ▶ Removable ceiling is not allowed
 - ▶ All ceiling penetrations must be air sealed
 - ▶ Recessed ceiling fixtures must be enclosed in air tight boxes and insulated



Insulation Details

1. Soffit Vent
2. Ridge Vent
3. Gable Vent at End Walls
4. Polyethylene Baffle Membrane
5. 2" Clear Space (for air movement)
6. Insulated Thermal envelope
7. Building thermal envelope



Insulation Requirements:

- ❑ Minimum R-38 is required over attic
 - ▶ If compression of insulation occurs at wall top plate & eaves
 - ▶ R-30 allowed if no compression occurs
- ❑ Insulation (air permeable type) must be installed with protective cover or baffle along air flow path & at vertical edges
 - ▶ To prevent retardation of insulation performance
 - ▶ To eliminate the risk of insulation displacement or disturbance due to air flow
 - ▶ 2" clear space required between insulation baffle and deck to allow for free flow of air

Vented Attic – Insulation Details

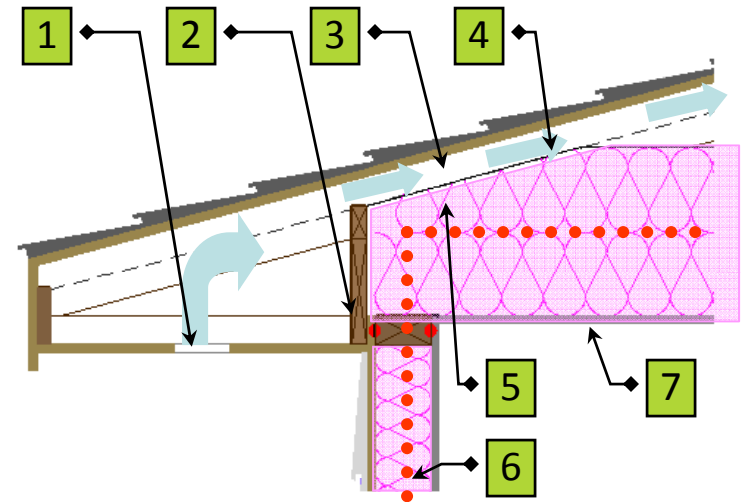

Insulation Details

1. Soffit Vent
2. Vertical support for insulation
3. 2" clear air space for air flow
4. Polyethylene Baffle Membrane
5. R-38 Insulation required (if Compression occurs at top plate & eaves)
6. Building Thermal envelope
7. Air tight ceiling

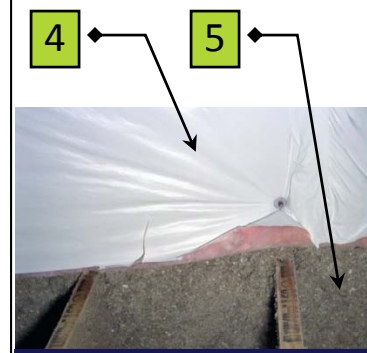

Photo: Courtesy of DOE/NREL



Construction Requirements:

- ❑ Attic is not vented to outside
- ❑ Building thermal envelope occurs along roof deck
 - ▶ Attic space is considered conditioned
 - ▶ Hot Deck Design
- ❑ Insulation must be installed along roof deck
 - ▶ Vapor retarder type 1 & 2 cannot be installed on ceilings
- ❑ Wood shingle or shakes requires ¼" vented air space between shingles and roofing underlayment

Unvented Attic – Insulation Details

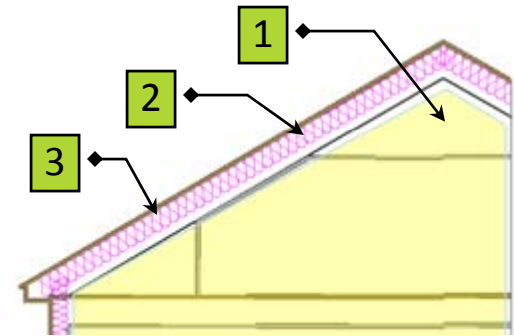

Insulation Details

1. Unvented Attic – Conditioned space
2. Building Thermal envelope along roof deck
3. Insulation (Air Impermeable Type) in contact with roof deck



Insulation Requirements:

- ❑ Total value of insulation must be R-38 or higher
- ❑ Insulation placement depends on Air Permeability of Insulation
 - ▶ Air Impermeable (Spray Foam)
 - » R-38 Insulation installed in direct contact with underside of structural roof sheathing
 - ▶ Air Permeable (Fiberglass / Cellulose)
 - » R-15 Rigid Board insulation required to be installed above roof sheathing in addition to R23 or higher air permeable insulation below roof sheathing
 - ▶ Air Impermeable + Air Permeable
 - » Air impermeable (Spray Foam) layer (R-15 or higher) installed in direct contact with underside of structural roof sheathing
 - » Additional Air permeable layer (Fiberglass or Cellulose) with R-23 or higher installed below the spray foam insulation

R-38 Spray Foam

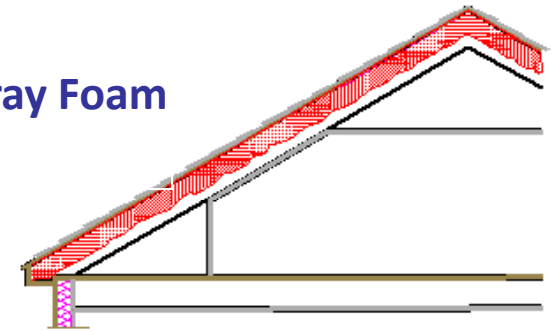

R-15 Rigid (Abv. Sheathing) + R-23 Fiberglass

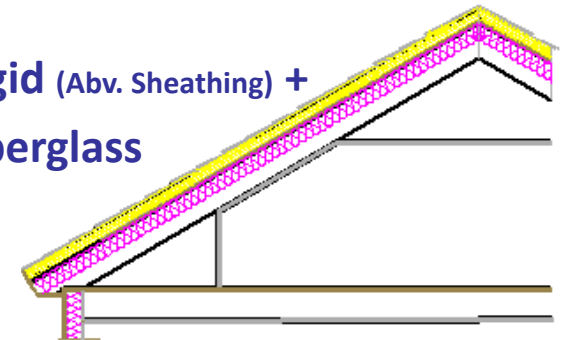

R-15 Spray Foam + R-23 Fiberglass

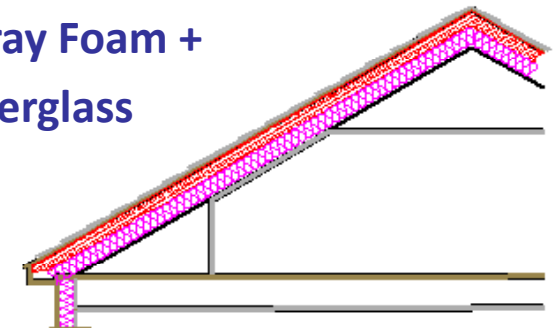

Unvented Crawl Spaces

- ❑ Insulation required in crawl space wall if it is part of the continuous building thermal envelope
- ❑ Insulation value must follow tables 402.1.1 & 402.1.3
 - ▶ Maximum allowed assembly U-0.065
 - ▶ Minimum required R-10 continuous or
 - ▶ Minimum required R-13 within cavity for non metal framed walls
 - ▶ Insulation must be continuous below floor and finish grade and extend 24" vertical or horizontal
 - ▶ Duct insulation is optional as it is located within thermal boundary
- ❑ Damp proofing and vapor barrier required to prevent moisture migration from soil into conditioned crawl spaces

Vented Crawl Spaces

- ❑ Need insulation installed in the floor separating conditioned and unconditioned spaces
 - ▶ Crawl space wall is no longer part of thermal boundary

Crawl Space Wall

Details

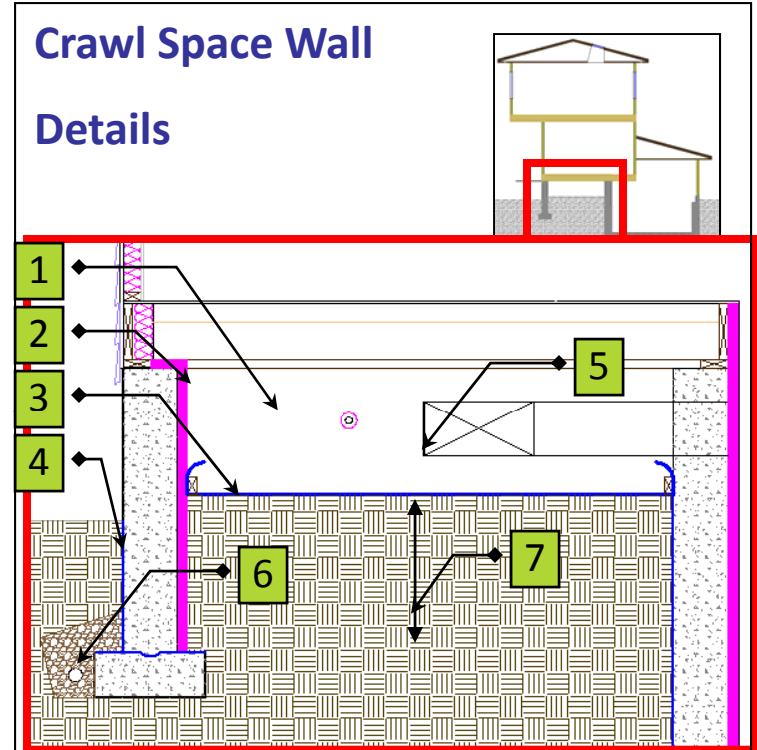

1. Unvented Crawl Space
2. R-10 Rigid Insulation
3. Polyethylene Vapor Barrier
4. Damp Proofing
5. Duct (inside conditioned space)
6. Foundation Drain
7. 24" Minimum Depth for insulation



Insulation & Placement

- ❑ R-10 continuous rigid type insulation installed on the inside or outside

OR

- ❑ R-13 cavity type insulation installed on inside

OR

- ❑ U-Factor is 0.059 or lower for assembly

- ❑ Insulation must extend from top of wall down to 10' below grade, or to top of floor, whichever comes first.
 - ▶ Not required if the basement is unheated and the floor above is insulated

Basement Wall

1. Cavity Insulation (R-13)
2. Basement Wall
3. Rigid Insulation (R-10)
4. Drainage plane / Vapor Barrier
5. Rigid Insulation (R-15 below slab – for heated slabs)
6. Foundation Drain

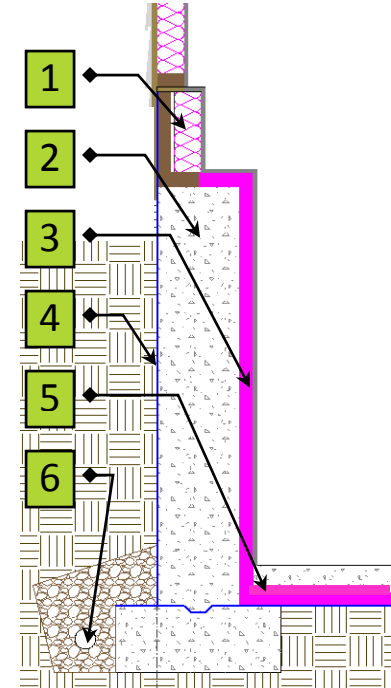

Insulation:

- R-10 for unheated slabs
- R-15 for heated slabs

Placement:

- Insulation must start on top of slab edge and extend 24", vertically or horizontally and outside or inside of foundation walls below exterior finished grade
- Thermal break must be provided between slab & foundation wall if insulation is placed on the inner face of foundation wall
 - ▶ Use rigid type insulation and protect the weather exposed sections with permanent weather resistant cover material

Options for Insulation Placement

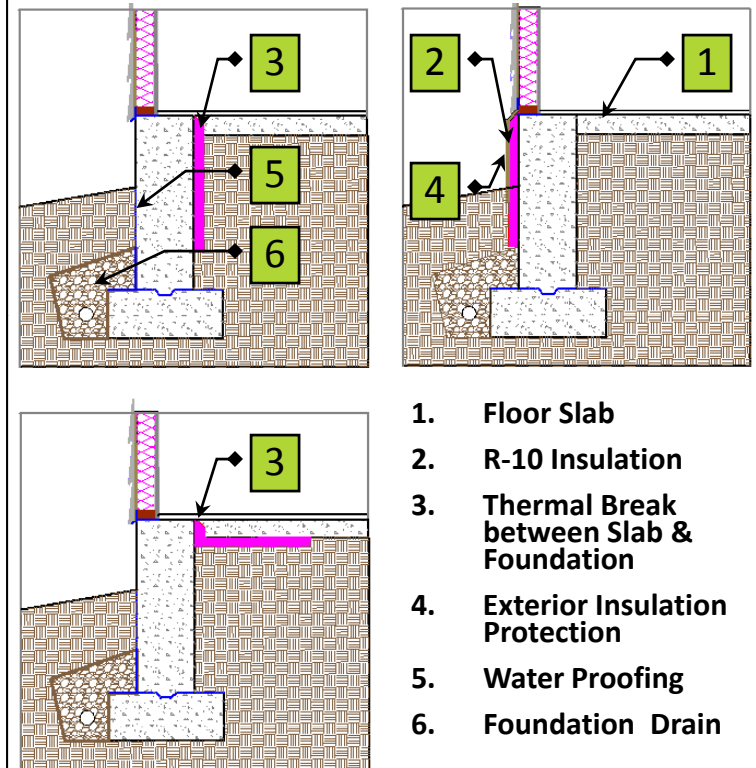

1. Floor Slab
2. R-10 Insulation
3. Thermal Break between Slab & Foundation
4. Exterior Insulation Protection
5. Water Proofing
6. Foundation Drain



Insulation must be installed & protected at time of foundation inspection.



Insulation:

- ❑ Required if floor separates conditioned & unconditioned spaces
- ❑ Wood Joist Floor: R-19
- ❑ Steel Joist Floor (2x6 construction): R-19 cavity + R-6 continuous
- ❑ Steel Joist Floor (2x8 or 2x10): R-19 cavity + R-12 continuous
- ❑ Assembly U-Factor: 0.047
- ❑ Use impermeable, vapor retardant type of insulation if moisture risk exists

Placement:

- ❑ Insulation must maintain permanent contact with sub-floor
- ❑ Insulation must be protected from exposure to elements, moisture

Insulated Floor

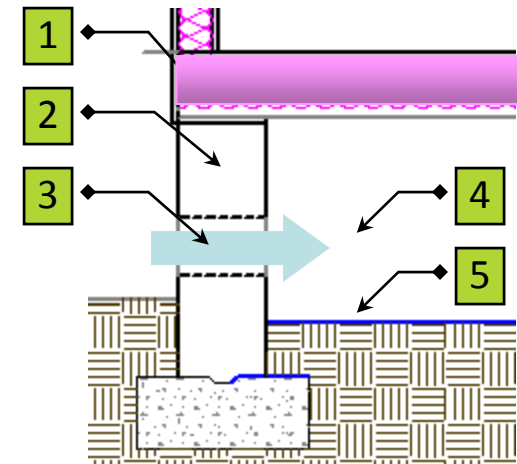

1. Insulation placed in contact with subfloor
2. Foundation wall
3. Venting
4. Unconditioned Crawl Space
5. Moisture barrier



4. Insulation Requirements What are the Applicable Inspections for Residential Building Envelope?

 Inspection / Test	Frequency
<p>Insulation Placement and R-Values</p> <p>Installed insulation for each component of the conditioned space envelope and at junctions between components shall be visually inspected to ensure that the R-Values are marked, that such R-Values conform to the R-Values identified in the construction documents and that the insulation is properly installed. Certifications for unmarked insulation shall be similarly visually inspected.</p>	<p>As required to verify continuous enclosure while walls, ceilings and floors are open</p>
<p>Permanent Certificate</p> <p>The installed permanent certificate shall be visually inspected for location, completeness and accuracy.</p>	<p>Prior to final plumbing, electrical and/or construction inspection as applicable</p>
<p>Air Sealing and Insulation – Visual Inspection or Testing</p> <p>See Air & Moisture Control section of this Module.</p>	

Coverage

- ❑ Applies to Doors & Windows
- ❑ Includes replacement units if sash & frame are replaced

U Factor Requirement: 0.35 or lower

- ❑ Prescriptive path:
 - ▶ Area Weighted average U-Factor of all fenestration products (excluding skylights) should be 0.35 or lower
 - ▶ Exemption per dwelling unit
 - » Up to 15 ft² of glazing (single or multiple units)
 - » 1 single side hinged door of up to 24ft²
- ❑ Trade-Off path (Total UA Alternative):
 - ▶ Area-weighted average (UA Method) accounting for all thermal envelope components is allowed
 - » 15 ft² exemptions cannot be taken under Trade-Off path
 - » Maximum allowed average U-Factor for fenestration is 0.48



U-Factor values can be found on NFRC labels that are typically affixed on each window by manufacturer. Retain these labels on windows for progress inspections.



Fenestration Requirement

- ❑ U Factor of 0.35 or lower required on an average for all fenestration products or as part of total general building's weighted average UA Calculation
- ❑ Special Exemption for 15ft² of glazed area per dwelling unit under prescriptive method

Recommended Window Types:

- ❑ High-performance double-glazed, low-E wood- or vinyl-framed windows will typically meet U-0.35 requirement
- ❑ Double-glazed metal-framed windows will have difficulty meeting U-0.35 requirement
 - ▶ Complete thermal break, very high-performance glass, triple-pane assembly may be required for metal-framed windows to meet this standard



 National Fenestration Rating Council® CERTIFIED	World's Best Window Co. Millennium 2000+ Vinyl-Clad Wood Frame Double Glazing • Argon Fill • Low E Product Type: Vertical Slider	
	ENERGY PERFORMANCE RATINGS	
U-Factor (U.S./I-P) 0.30	Solar Heat Gain Coefficient 0.30	
ADDITIONAL PERFORMANCE RATINGS		
Visible Transmittance 0.51	Air Leakage (U.S./I-P) 0.2	
<small>Manufacturer stipulates that these ratings conform to applicable NFRC procedures for determining whole product performance. NFRC ratings are determined for a fixed set of environmental conditions and a specific product size. NFRC does not recommend any product and does not warrant the suitability of any product for any specific use. Consult manufacturer's literature for other product performance information. www.nfrc.org</small>		



Fenestration Requirement

- ❑ U Factor of 0.35 or lower required on an average for all fenestration products or as part of total general building's weighted average UA Calculation
- ❑ Special Exemption for 15ft² of glazed area per dwelling unit under prescriptive method

Recommended Window Types:

- ❑ High-performance double-glazed, low-E wood- or vinyl-framed windows will typically meet U-0.35 requirement
- ❑ Double-glazed metal-framed windows will have difficulty meeting U-0.35 requirement
 - ▶ Complete thermal break, very high-performance glass, triple-pane assembly may be required for metal-framed windows to meet this standard



 NFRC Labels must be retained on windows for inspections. U-Value to be verified on labels



U-Factor Requirement 0.60 or lower required for each skylight assembly

- Fiberglass-insulated panel types and triple- or quadruple-paned glass skylights will typically meet this spec

Skylight Curb or Knee Wall must be insulated if it becomes part of building thermal boundary

Area Weighted Average allowed to meet the compliance requirements

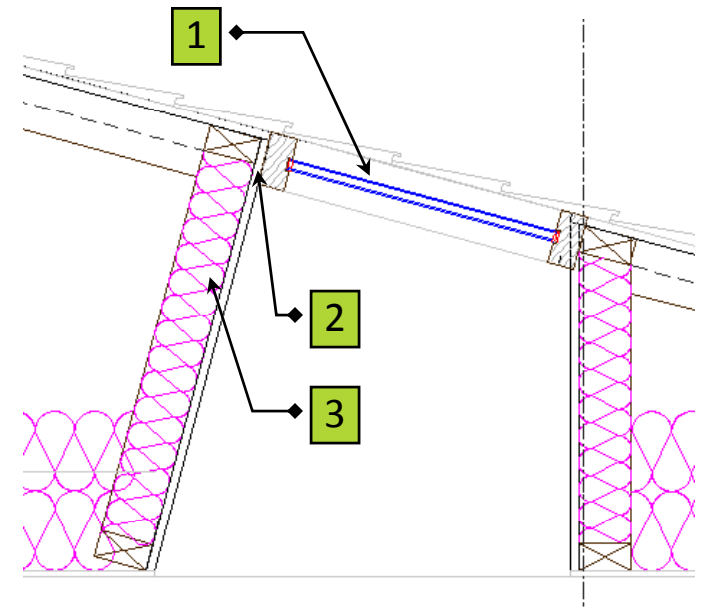

1. Skylight
2. Air Sealing & Flashing
3. Insulated Curb / Knee Walls





Floor Area Limitation

- ❑ Can only be up to 500 ft² per dwelling unit, single story
- ❑ Thermally isolated from main building
 - ▶ Walls, doors & windows separating the Sun Room from the main residence must meet building thermal envelope criteria (as if the Sun Room were unconditioned)

Thermal Requirements for Sun Room

- ❑ Ceilings: R-19
- ❑ Walls: R-13
- ❑ Fenestration: U-0.50
- ❑ Skylights: U-0.75



Photo: Courtesy of DOE/NREL



The thermal performance values for Sun Rooms are less stringent than typical construction, but only if they are thermally isolated from the main residence.





Inspection / Test

Frequency

Fenestration Thermal Values and Product Ratings

U-Factors of installed fenestration shall be **verified by visual inspection** for conformance with the U-Factors identified in the construction drawings, either by **verifying the manufacturer's NFRC labels** or, where not labeled, using the ratings in NYCECC Tables 303.1.3(1) and (2).

As required to verify continuous enclosure while walls, ceilings and floors are open

Fenestration Product Ratings for Air Leakage

Windows, skylights and sliding glass doors, except site-built windows, skylights and doors, shall be **visually inspected to verify that installed assemblies are listed** and labeled to the referenced standard.

As required during installation

Fenestration Areas

Dimensions of windows, doors and skylights shall be verified by visual inspection

Prior to final construction inspection





In this section you will learn about:

- ❑ Concepts and requirements for air leakage control, testing and inspection requirements; and
- ❑ Concepts and recommended practices for moisture management.

Air Leakage:

- ❑ Uncontrolled leakage of air from conditioned spaces to unconditioned spaces (exfiltration) or vice versa (infiltration), usually at building thermal envelope boundary
- ❑ Air leakage usually occurs through cracks in building envelopes
- ❑ Leads to energy waste & comfort issues
- ❑ May lead to moisture issues within assemblies

Code Requirement:

- ❑ Air leakage must be controlled by attention to details in air-sealing activity during construction
- ❑ Air leakage must be kept below threshold and proven via testing or detailed visual inspections.



Photo: Courtesy of DOE/NREL

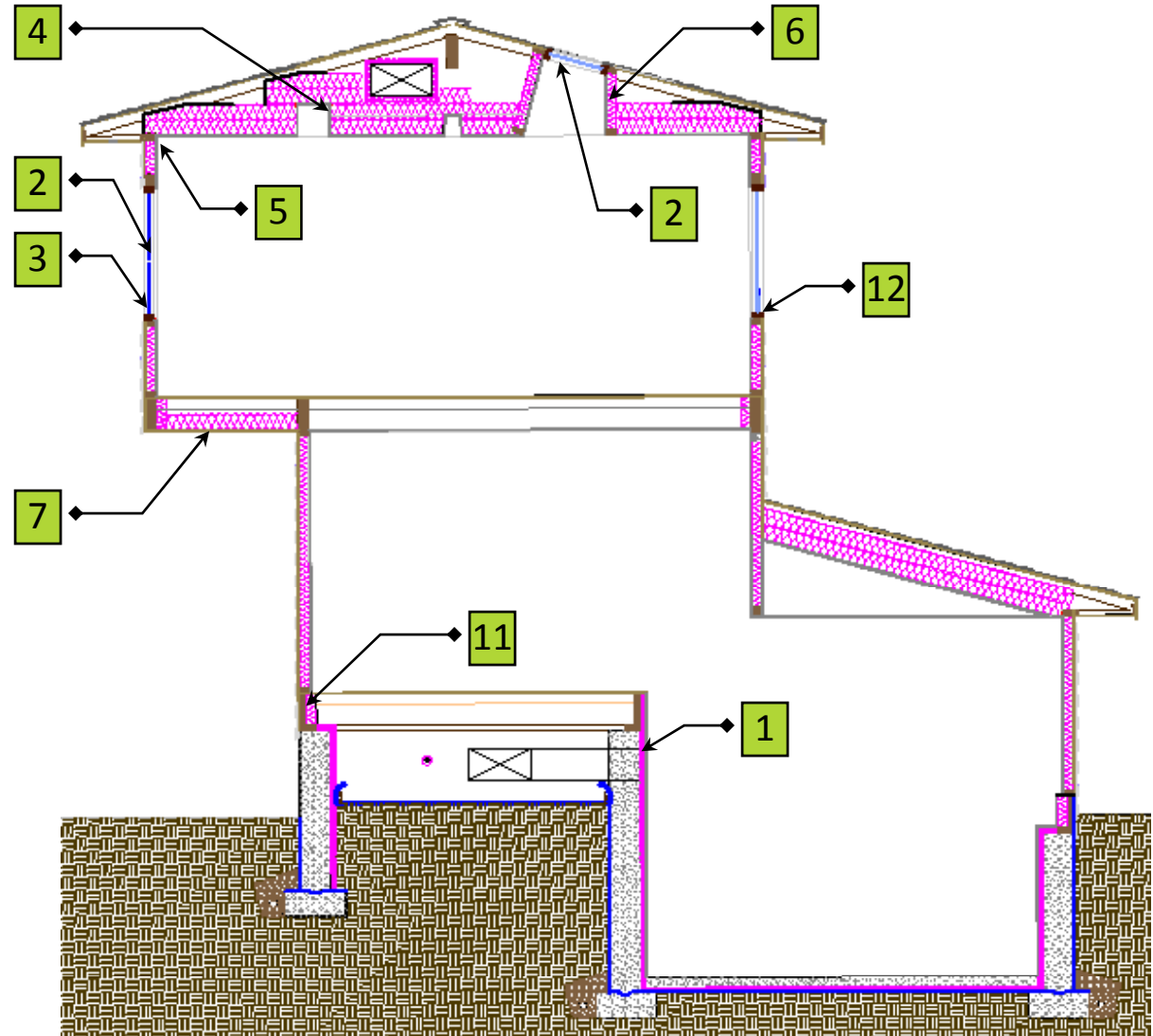

Photo: Courtesy of DOE/NREL



Air Leakage: Critical Areas

1. All Joints, Seams & Penetrations
2. Site-built windows, doors & skylights
3. Openings between window and door assemblies and their respective jambs and framing
4. Utility Penetrations
5. Dropped ceiling or chases adjacent to the thermal envelope
6. Knee walls
7. Walls & ceilings separating garage from conditioned space
8. Behind tubs & showers on exterior walls
9. Common walls between dwelling units
10. Attic access openings
11. Rim joist junctions
12. Sill plates & headers





Inspection / Test

Frequency

Air Sealing and Insulation – Visual Inspection

Openings and penetrations in the building envelope, including site-built fenestration and doors, shall **be visually inspected to verify that they are properly sealed**, in accordance with Table 402.4.2.

As required during envelope construction

Air Sealing and Insulation – Testing

Testing shall be performed in accordance with section NYCECC 402.4.2.1 and shall be accepted if the building meets the requirements detailed in such section. Test results shall be retained in accordance with the provisions of Title 28..

Prior to final construction inspection



Blower Door Test:

- ❑ Less than 7 ACH per hour at 50 Pa
 - ▶ ASHRAE / ASTM E779
 - ▶ Testing is typically challenging for larger building ~ 20,000 sf. or more
 - ▶ Multiple doors must be used in proportion to size of the building
 - ▶ Use infrared testing if blower-door test fails to identify leaky spots
- ❑ Testing must be carried out after rough-in after penetrations
- ❑ Rules during Testing
 - ▶ Refer to code (7 conditions)
- ❑ Qualified person must perform test
 - ▶ Provide copy of test results
 - ▶ Certification (Refer to Code for details)



Photo: Courtesy of DOE/NREL



- ❑ Detailed visual inspection can be used to demonstrate compliance in lieu of a blower door test
- ❑ Inspection must be undertaken by an independent third-party qualified person
 - ▶ Cannot be installer
- ❑ Placement of Insulation and air barrier must be verified
- ❑ Refer Table 402.4.2 for components that need to be verified
 - ▶ Maintain photo documentation of inspections

Photo: Courtesy of DOE/NREL



Photo: Courtesy of DOE/NREL



- ❑ Not required in above grade walls & floors in Zone 4. Recommended as beyond-Code practice
 - ▶ Preferably placed on the warm side – Interior face for cold climates
 - » Warm side holds more moisture
 - ▶ See also NYC Building Code regarding vapor retarders.

- ❑ Recommended Practice (Beyond-Code)
 - ▶ Flashing Details: Capillary break
 - ▶ Gutters, spouts, drains: Remove water away from structure

Class II Vapor Retarder Installed on Inside Face



Description

- ❑ Also called Vapor Diffusion Retarders (VDR)
 - ▶ Old term is Vapor Barrier
- ❑ Membrane or coating that retards flow of moisture
- ❑ Performance measured in “Perms”
 - ▶ Definition: At 73.4°F the number of grains of water vapor passing through a square foot of material per hour at a differential vapor pressure equal to one inch of mercury(1”W.C.)
 - ▶ Any material with Perm < 1 is a vapor retarder

Types

- ❑ Class I: Sheet polyethylene, unperforated Aluminum foil
 - ▶ For buildings experiencing moisture problems, consider Class II
- ❑ Class II: Kraft faced fiber glass batts or low perm rated paints
 - ▶ Suitable for most buildings in Zone 4
- ❑ Class III: Latex or Enamel Paint
 - ▶ Suitable for most buildings in Zone 4

Moisture Management Techniques in Crawl Space

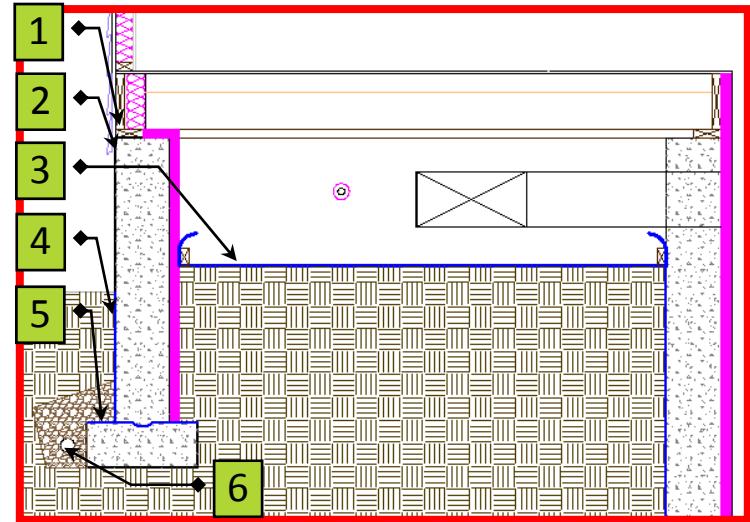

1. Untreated Wood must be kept away from ground contact
2. Flashing must be used to prevent migration of moisture from foundation to wall
3. Polyethylene Vapor Barrier to retard moisture migration from ground Damp Proofing
4. Damp proofing & surface slope to move water and moisture away from foundation
5. Drainage Plane over damp proofing to move moisture to foundation drain
6. Foundation drain



Vented Cladding

- Vented design is not required in Climate Zone 4, but a good practice for high moisture-exposed envelopes

Siding Material	Clear Air Space Behind Siding	Vent Opening Size	Vent Opening Locations / Placement
	Inches	Inches	Type
Stucco	3/8	3/8	Continuous Slot @ Top & Bottom
Brick	2	3/8 x 2	Every 3 rd Brick @ Top & Bottom
Stone	2	1 sq. in.	Per 24 inches of horizontal wall length
Masonry Veneer	2	1 sq. in.	Per 24 inches of horizontal wall length
Panel Siding	3/8	3/8	Continuous Slot @ Top & Bottom
Wood	1/4	NR	or 1/4 inch gap @ horizontal siding laps
Fiber Cement	1/4	NR	or 1/4 inch gap @ horizontal siding laps
Vinyl	NR	NR	Weather-resistive barrier required
Manufactured stone Veneer	3/8	3/8	Continuous Slot @ Top & Bottom



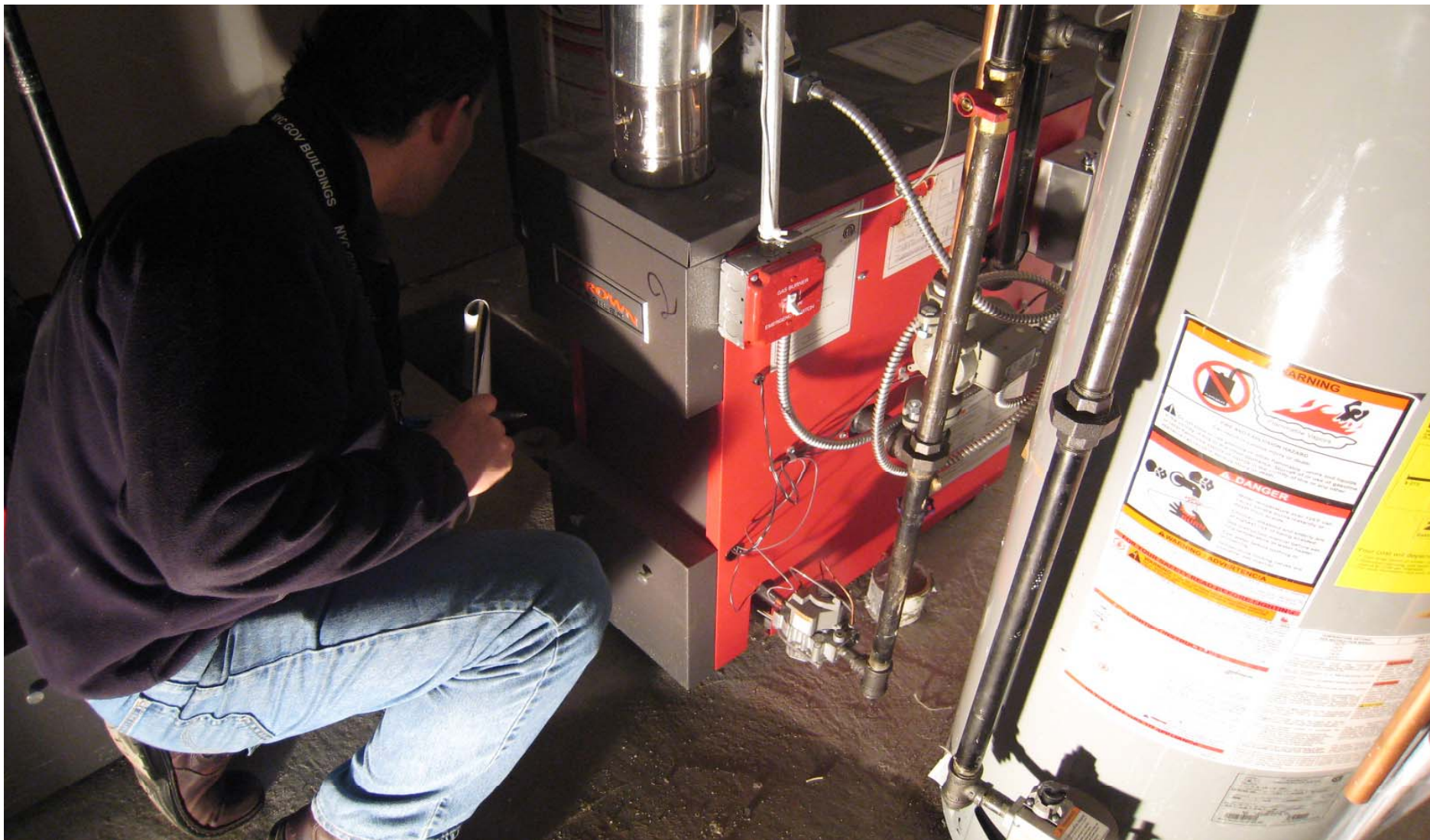

In this section you will learn about:

- ❑ Requirements for equipment sizing, HVAC controls including programmable thermostats and heat pumps;
- ❑ Insulation and air-sealing requirements for ducts and pipes;
- ❑ Requirements for swimming pools and snow melt systems;
- ❑ Lamp-efficiency requirements; and
- ❑ Electrical metering requirements.

Equipment Sizing

- ❑ Sizing calculation must be performed for each project based on ACCA Manual J (or similar method as approved in Residential Code of NYS)
 - ▶ Applicable to systems serving 1 or 2 dwelling units
 - ▶ Systems serving 3 or more dwelling units shall follow requirements for commercial systems and follow ACCA/ASHRAE Standard 183 for load calculations



Photo: Courtesy of DOE/NREL



Thermostat

- ❑ At least one thermostat per heating & cooling system
- ❑ At least one programmable thermostat per dwelling unit
 - ▶ Automatic adjustment in response to thermostat for largest heating or cooling zone
 - ▶ Capability for 7-Day unique schedules
 - ▶ Thermostat should be able to revert to set back as programmed
 - » Heating: 70°F (set point) & 55°F (set back)
 - » Cooling: 78°F (set point) & 85°F (set back)

Heat Pump Supplementary Heat

- ❑ Controls to limit the use of electric heat for supplemental heat and defrost cycles.

Programmable Thermostat



6. M / E / P Systems  What are the Applicable Inspections for Residential Mechanical and Plumbing Systems?

 Inspection / Test	Frequency
<p>Fireplaces</p> <p>Provision of combustion air and tight-fitting fireplace doors shall be verified by visual inspection.</p>	Prior to final construction inspection
<p>Outdoor Air Intake and Exhaust Dampers</p> <p>Not less than 20% of installed automatic or gravity dampers, and a minimum of one of each type, shall be visually inspected and physically tested for proper operation.</p>	Prior to final construction inspection
<p>Equipment</p> <p>Heating and cooling equipment shall be verified by visual inspection for proper sizing. Pool heaters and covers shall be verified by visual inspection.</p>	Prior to final plumbing and construction inspection
<p>Controls</p> <p>System controls shall be inspected to verify that each dwelling is provided with at least one individual programmable thermostat with capabilities as described in NYCECC 403.1.1, and that such controls are set and operate as specified in NYCECC 403.1.1.</p> <p>Controls for supplementary electric-resistance heat pumps shall be inspected to verify that such controls prevent supplemental heat operation when the heat pump compressor can meet the heating load. Controls for snow- and ice-melting systems and pools shall be inspected for proper operation. Not less than 20% or one of each control type, whichever is more, shall be inspected.</p>	Prior to final electrical and construction inspection



Inspection / Test

Frequency

Maintenance Information

Maintenance manuals for equipment and systems requiring preventive maintenance shall be **reviewed for applicability to installed equipment and systems** before such manuals are provided to the owner. Labels required for such equipment or systems shall be inspected for accuracy and completeness.

Prior to sign-off or issuance of Certificate of Occupancy

Permanent Certificate

The installed permanent certificate shall be **visually inspected for location, completeness and accuracy**.

Prior to final plumbing, electrical and/or construction inspection as applicable



Insulation Requirement

- ❑ Minimum required R-8 for supply ducts
- ❑ Minimum required R-6 for other ducts
 - ▶ Exceptions for ducts located completely within thermal envelope
 - » Heat loss / gain are expected to be minimal if the ducts are located within thermal envelopes

Prohibited Framing Cavities

- ❑ Framing cavities cannot be used for supply ducts
 - ▶ To avoid heat loss/gain at exterior walls
 - ▶ To avoid supply air leakage

Duct Placed in Vented Attic

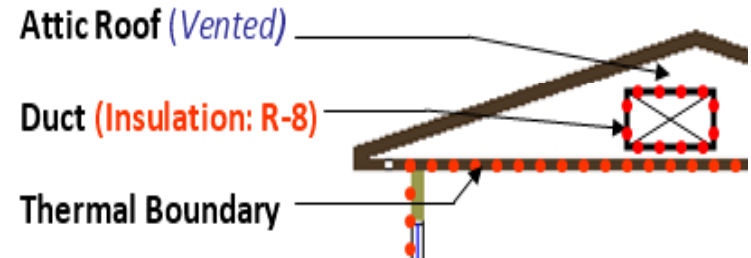

Duct Placed in Unvented Attic

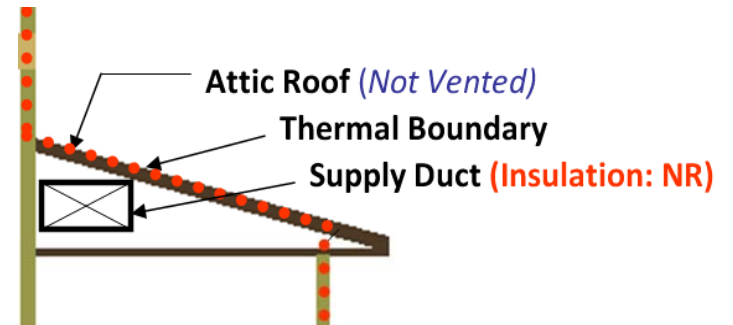

Air Sealing Requirements

- ❑ Required for ducts, air handlers, filter boxes
 - ▶ Typically required if they are found in vented attics & crawl spaces, unconditioned mechanical rooms, etc.
- ❑ Joints & seams must comply with Residential Code
- ❑ Duct air-tightness must be verified unless air handler and all ducts are located within conditional space
 - ▶ Test at 25 Pascals, all registers must be taped
- ❑ Method 1 – Post Construction Test:
 - ▶ Total leakage must be < 12 CFM / 100 sf of conditioned floor area when tested with air handler or 8 CFM without air handler
- ❑ Method2 – Rough-In Test:
 - ▶ Total leakage must be < 6 CFM / 100 sf of conditioned floor area when tested with air handler or 4 CFM without air handler



Piping Insulation

- Minimum required is R-3 if the pipe carries fluids greater than 105° F or below 55° F

Circulating Service Hot Water Systems

- Piping insulation should be minimum of R-2
- Include an automatic or readily accessible manual shut-off for hot water pump when not in use

Mechanical Ventilation

- Outdoor air intakes should have automatic or gravity dampers that close when the system is not in use





Inspection / Test

Frequency

Duct and Piping Insulation

Installed duct and piping insulation shall be **visually inspected to verify correct insulation placement and values.**
Ducts, air handlers, filter boxes and building cavities used as ducts shall be visually inspected for proper sealing.

Prior to closing ceilings and walls and prior to final construction inspection

Duct Leakage Testing

Where the air handler and/or some ductwork is in unconditioned space, duct-leakage **testing shall be performed either after rough-in or post-construction to ensure compliance with NYCECC 403.2.2.** Not less than 20% of such ductwork shall be tested.

Prior to closing ceilings and walls and prior to final construction inspection



Controls Requirement:

- ❑ Compliance required if snow-melt system's energy (hot water or electricity or fuel) is supplied from the building:
 - ▶ Automatic shut-off when pavement temperature is above 50°F and no precipitation
 - » Use Pavement Temperature Sensor & Snow/Precipitation Detector
 - ▶ Auto or Manual shut-off above 40°F
 - » Outdoor air temperature sensor tie-in
 - ▶ No requirements for Freeze Protection systems (Heat Trace)
 - » Recommended shut off at 40°F



On-Off Switch for Pool Heaters

- ❑ Must be readily accessible
- ❑ Shut-off should not alter thermostat setting
- ❑ Gas- or LPG-fired pool heaters should not have continuously burning pilots

Time Switches

- ❑ Automatic on-off switching capability based on schedule for controlling heaters & pumps
 - ▶ Exceptions: If public health standards require 24-hour pump operation
 - ▶ Pumps are integrated with solar or waste heat recovery pool heating systems

Pool Covers

- ❑ Vapor-retardant covers for heated pools
- ❑ Minimum R-12 insulation if pool is maintained at 90°F or higher



Efficiency Requirement

- ❑ 50% of lamps in permanently installed fixtures must be of High-efficacy Type
 - ▶ Efficacy is measure of lamp efficiency to produce light, measured in lumens / Watt
 - ▶ Since requirements are for lamps instead of fixtures, any fixture can be utilized so long as requirement can be met

- ❑ High-Efficacy lamp requirements:
 - ▶ Compact Fluorescent Lamps (CFL)
 - ▶ Linear Fluorescent Lamps: T8 or T5
 - ▶ Lamps \leq 15 Watts: 40 Lumens / Watt
 - ▶ Lamps 15 to 40 watts: 50 Lumens / Watt
 - ▶ Lamps $>$ 40 Watts: 60 Lumens / Watt

- ❑ T12 type Linear Fluorescents, Incandescent & Halogen lamps will not meet these efficacy requirements



Installation Requirements:

- ❑ Recessed ceiling luminaires or light fixtures installed in building thermal envelope (ceiling with insulation) should be rated for “IC” (Insulation Contact)
- ❑ Meet ASTM E 283 standard
 - ▶ Verify for air leakage rate < 2.0 CFM at 1.57 psf
- ❑ The ceiling junction must be sealed with gasket or caulk to avoid air leakage
- ❑ Non-IC rated fixtures need air-tight enclosure box to be constructed around the fixtures to avoid insulation contact and air leakage

“IC” Rated Luminaire:

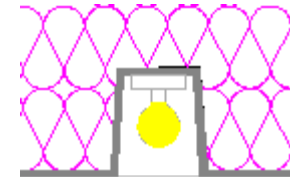

Luminaire can be installed in insulated ceiling. The ceiling penetration must be air sealed.

Non- IC Rated Luminaire:

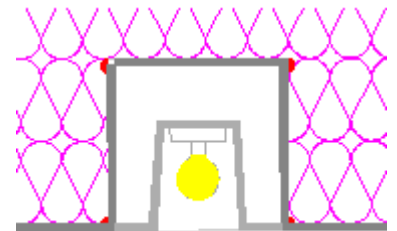

Air-tight enclosure must be built around fixture. Insulation must not come in contact with fixture housing



Metering Requirement

- ❑ Each dwelling unit must have capability to determine actual electrical usage
 - ▶ Individual meter or monitoring

- ❑ For existing buildings, dwelling units are exempt from individual metering requirements per LL88 of 2009.

Photo: Courtesy of DOE/NREL



6. M / E / P Systems  What are the Applicable Inspections for Residential Electrical and Lighting Systems?

 Inspection / Test	Frequency
<p>Electrical Metering</p> <p>The presence and operation of individual meters or other means of monitoring individual dwelling units shall be verified by visual inspection for all dwelling units.</p>	<p>Prior to final electrical and construction inspection</p>
<p>Lighting in Dwelling Units</p> <p>Lamps in permanently installed lighting fixtures shall be visually inspected to verify compliance with high-efficacy requirements.</p>	<p>Prior to final electrical and construction inspection</p>

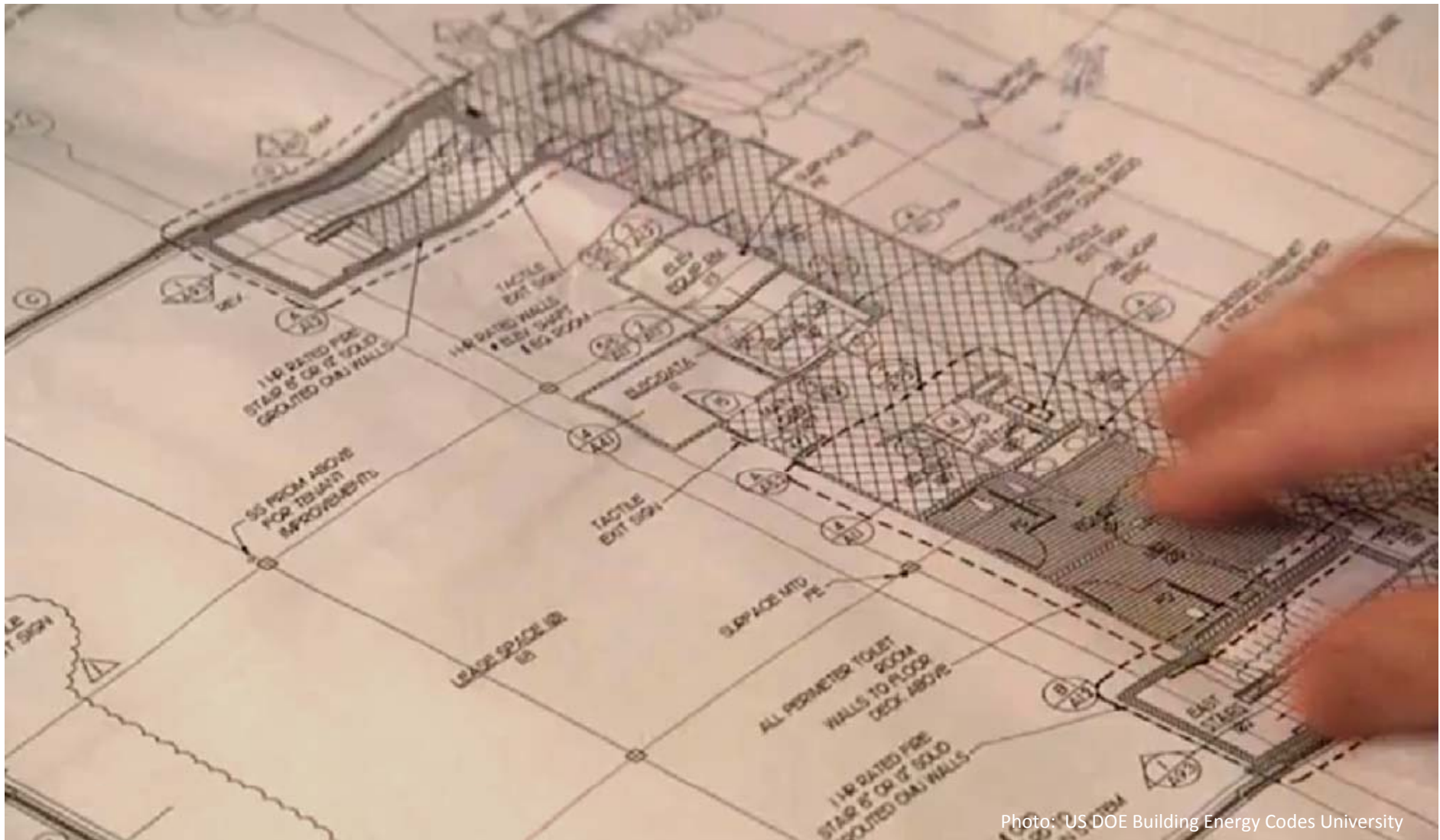

Photo: US DOE Building Energy Codes University

In this section you will learn about:

- Residential requirements for NYCECC Submissions, including:
 - ▶ Energy Analysis, and
 - ▶ Supporting Documentation

- Applicable Progress Inspections associated with residential buildings





Per 1 RCNY §5000-01

- ❑ A Professional Statement
- ❑ An Owner Statement
- ❑ An Energy Analysis
- ❑ Supporting Documentation, including required Progress Inspections

Approved Energy Analysis Methods

- ❑ Tabular Analysis: For prescriptive approach
- ❑ REScheck Software: For prescriptive and envelope trade-off approaches
- ❑ Simulated Performance Alternative: For whole-building approach



This Residential Module addresses only Energy Analysis, Supporting Documentation, and Progress Inspection issues. A full overview of the required submission documents, including Professional and Owner Statements, is included under the NYCECC Administrative Overview module in this series.





Option 1: Tabular Analysis

- The Tabular Analysis compares proposed values of each NYCECC-regulated item in the scope of work with the respective prescriptive values required by the Code.
 - ▶ Applicable to New Buildings, Additions, or Alterations
 - ▶ Demonstrates Prescriptive Compliance
 - ▶ Can be used with NYCECC



Residential documentation should be sure to include:

- ▶ **ALL** assemblies related to the scope of work (roofs, above grade walls, fenestration, below grade walls, etc.)
- ▶ **ALL** significant variations of envelope assemblies (different wall assemblies, glazing types, roof assemblies, door types, etc.)

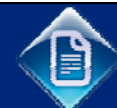

Sample Tabular Analysis - 1

Examples of Notes for Residential Alterations / Renovations

ITEM DESCRIPTION	PROPOSED DESIGN VALUE	CODE PRESCRIPTIVE VALUE AND CITATION	SUPPORTING DOCUMENTATION
BUILDING ENVELOPE			
Replace roof shingles and sheathing, add insulation to attic	Roof Type 1: R -38 fiberglass insulation in wood ceiling joists below vented attic space	Minimum R-38 ceiling insulation NYCECC Table 402.1.1	Roof Type 1: A-100 (Roof Plan) A-402 (Wall Sections) 7/A-603 (Roof Eave Detail)
Replace existing windows w/new wood framed windows, Floors 2 - 4	Window Type 1 +2 +3: U = 0.31 Air leakage 0.30 cfm/SF	Window Types A-D: Maximum U-Factor = 0.35 NYCECC Table 402.1.1 Maximum Air Leakage = 0.3 cfm/SF NYCECC 402.4.4	Window Types A-D: A-301-302 (Elevations) A-501 (Schedules)
Renovate interior side of exterior walls around new window openings – repair/replace gwb	No change proposed to existing 3 ½” wood stud walls which are completely filled with fiberglass batts (estimated R-3.1/inch).	NYCECC 101.4.3 Exception 3 – Alterations, renovations, or repairs to roof/ceiling, wall, or floor cavities which are insulated to full depth with insulation having a minimal nominal value of R-3.0/inch.	A-102-104 (Floor Plans) 1-2/A-305 (Interior Elevations)



Sample Tabular Analysis - 1

Examples of Notes for Residential Alterations / Renovations

ITEM DESCRIPTION	PROPOSED DESIGN VALUE	CODE PRESCRIPTIVE VALUE AND CITATION	SUPPORTING DOCUMENTATION
BUILDING ENVELOPE			
Replace roof shingles and sheathing, add insulation to attic	Roof Type 1: R -38 fiberglass insulation ceiling joists below vent space	Applicants must include reference to the applicable Supporting Documentation for EACH item within the Tabular Analysis.	Roof Type 1: A-100 (Roof Plan) A-402 (Wall Sections) 7/A-603 (Roof Eave Detail)
Replace existing windows w/new wood framed windows, Floors 2 - 4	Window Type 1 +2 +3: U = 0.31 Air leakage 0.30 cfm/SF		Window Types A-D: Maximum U-Factor = 0.35 NYCECC Table 402.1.1 Maximum Air Leakage = 0.3 cfm/SF NYCECC 402.4.4
Renovate interior side of exterior walls around new window openings – repair/replace gwb	No change proposed to existing 3 ½” wood stud walls which are completely filled with fiberglass batts (estimated R-3.1/inch).	NYCECC 101.4.3 Exception 3 – Alterations, renovations, or repairs to roof/ceiling, wall, or floor cavities which are insulated to full depth with insulation having a minimal nominal value of R-3.0/inch.	A-102-104 (Floor Plans) 1-2/A-305 (Interior Elevations)





Option 2: REScheck submissions

- REScheck software, available for free from the US Department of Energy, can be used to prepare Energy Code compliance calculations.
 - ▶ Demonstrates Prescriptive Compliance, with Trade-Offs allowed among different envelope assemblies (roofs, walls, glazings, etc.)
 - ▶ Only New York State NYCECC REScheck forms are permitted (not IECC)
 - ▶ Downloads: <http://www.energycodes.gov/software.stm>



Envelope input in REScheck should be sure to include:

- ▶ **ALL** assemblies related to the scope of work (roofs, above grade walls, fenestration, below grade walls, etc.)
- ▶ **ALL** significant variations of envelope assemblies (different wall assemblies, glazing types, roof assemblies, door types, etc.)

7. Submissions & Inspections

Residential_rev.rck - REScheck 4.4.1 Code: 2010 New York Energy Conservation Construction Code

File Edit View Options Code Tools Help

Project Envelope Mechanical

Ceiling Skylight Wall Window Door Basement Floor Crawl Wall

	Component	Assembly	Gross Area		Cavity Insulation R-Value	Continuous Insulation R-Value	U-Factor	UA	SHGC
Building									
1	Exterior Wall Type A	Steel Frame, 16" o.c.	1260	ft2	13.0	5.0	0.077	88	
2	Window 2	Wood Frame:Double Pane with Low-E	75	ft2			0.33	25	0.30
3	Door B	Solid	41	ft2			0.42	17	
4	Exterior Wall Type B	Steel Frame, 16" o.c.	2513	ft2	13.0	5.0	0.077	173	
5	Window 1	Wood Frame:Double Pane with Low-E	210	ft2			0.33	69	0.30
6	Window 2	Wood Frame:Double Pane with Low-E	30	ft2			0.33	10	0.30
7	Window 3	Wood Frame:Double Pane with Low-E	5	ft2			0.33	2	0.30
8	Door A	Glass	24	ft2			0.31	7	0.21
9	Roof Type 1	Steel Joist/Rafter, 16" o.c.:2x10	823	ft2	0.0	35.0	0.027	21	
10	Window 4 - Skylight	Metal Frame with Thermal Break:Triple Pane	32	ft2			0.7	22	0.30
11	Window 5 - Skylight	Other	9	ft2			0.54	5	0.24

Passes 12.2 % Better Than Code

Compliance Method: UA Trade-Off Max. UA Your UA

Select the building assembly buttons above the column headers to create a list of envelope components for the building.



7. Submissions & Inspections

Residential_rev.rck - REScheck 4.4.1 Code: 2010 New York Energy Conservation Construction Code

File Edit View Options Code Tools Help

Project Envelope Mechanical

Ceiling Skylight Wall Window Door Basement Floor Crawl Wall

Component	Assembly	Gross Area	Cavity Insulation R-Value	Continuous Insulation R-Value	U-Factor	UA	SHGC		
Building									
1	Exterior Wall Type A	Steel Frame, 16" o.c.	1260	ft2	13.0	5.0	0.077	88	
2	Window 2	Wood Frame:Double Pane with Low-E	75	ft2			0.33	25	0.30
3	Door B	Solid	41	ft2			0.42	17	
	Exterior Wall Type B	Steel Frame, 16" o.c.	2513	ft2	13.0	5.0	0.077	173	
	Window 1	Wood Frame:Double Pane with Low-E	210	ft2			0.33	69	0.30
	Window 2	Wood Frame:Double Pane with Low-E	30	ft2			0.33	10	0.30
	Window 3	Wood Frame:Double Pane with Low-E	5	ft2			0.33	2	0.30
8	Door A	Glass	24	ft2			0.31	7	0.21
9	Roof Type 1	Steel Joist/Rafter, 16" o.c.:2x10	823	ft2	0.0	35.0	0.027	21	
10	Window 4 - Skylight	Metal Frame with Thermal Break:Triple Pane	32	ft2			0.7	22	0.30
11	Window 5 - Skylight	Other	9	ft2			0.54	5	0.24

Select the building assembly buttons above the column headers to create a list of envelope components for the building.



Use consistent assembly labels in both REScheck and the Supporting Documentation – see sample documents at the end of this Section.

There are some limitations to the trade-off approach in residential construction. An applicant cannot exceed maximum allowed U-Factors for vertical fenestration (0.48) or skylights (0.75) in Zone 4.



Intent

- ❑ Allows use of advanced techniques to credit energy-efficiency measures (e.g. Energy Recovery Ventilation) not accounted for in other paths, or
- ❑ Used for Trade-Offs among disciplines when all prescriptive requirements cannot be met

Process

- ❑ Addresses energy costs of heating, cooling, and service water heating
 - ▶ Excluded: Energy use of Lighting & Appliances
 - ▶ Allows credit for onsite renewables, such as solar HW or PV
- ❑ Compliance demonstrated if energy cost of Proposed Design is equal to or lower than Standard Reference Design
 - ▶ Proposed Design: User defined
 - ▶ Reference Design: Generated by software program (users cannot change it)
- ❑ All mandatory requirements of building envelope must be met

7. Submissions & Inspections

Software Tools

- ❑ Must be approved by the NYS Secretary of State and the DOB Commissioner
- ❑ Listed programs in NYCECC 101.5.1:
 - ▶ REScheck (Performance Method)
 - ▶ REM/Rate (subject to advance approval by the Commissioner, per 1 RCNY §5000-01)
 - ▶ REM/Design home (subject to advance approval by the Commissioner, per 1 RCNY §5000-01)
 - ▶ Home Energy Rating Software (HERS) (subject to advance approval by the Commissioner, per 1 RCNY §5000-01)

Supporting Documentation should:

- Support the values submitted in the Energy Analysis
- Verify mandatory requirements of the NYCECC are met
- List and describe each applicable progress inspection as required based on the scope of work, per Table I of 1 RCNY §5000-01.



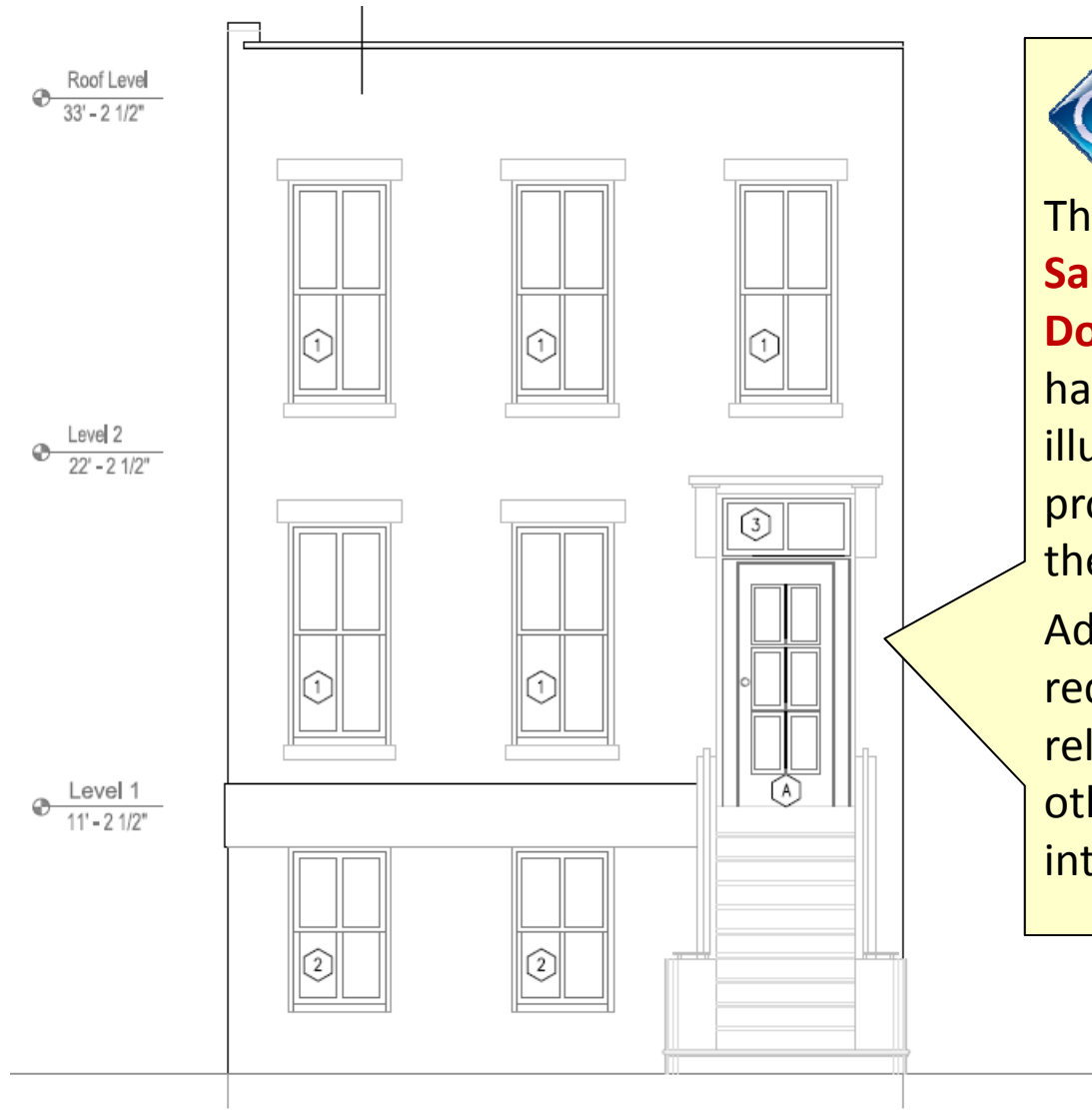

The following **Sample Supporting Documentation**

has been developed to illustrate compliance procedures related to the **NYCECC only.**

Additional information required by the DOB related to zoning and other Code provisions is intentionally omitted.

7. Submissions & Inspections

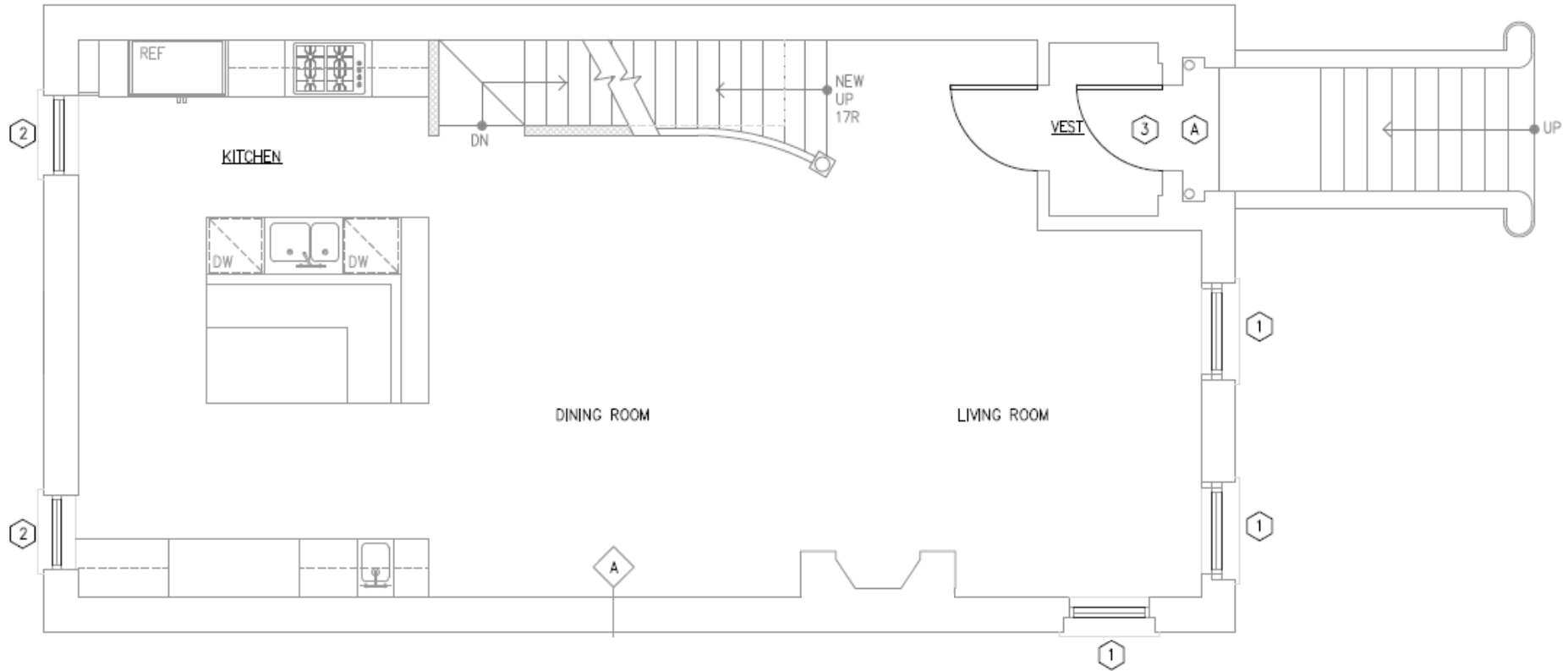

1st FLOOR PLAN



7. Submissions & Inspections

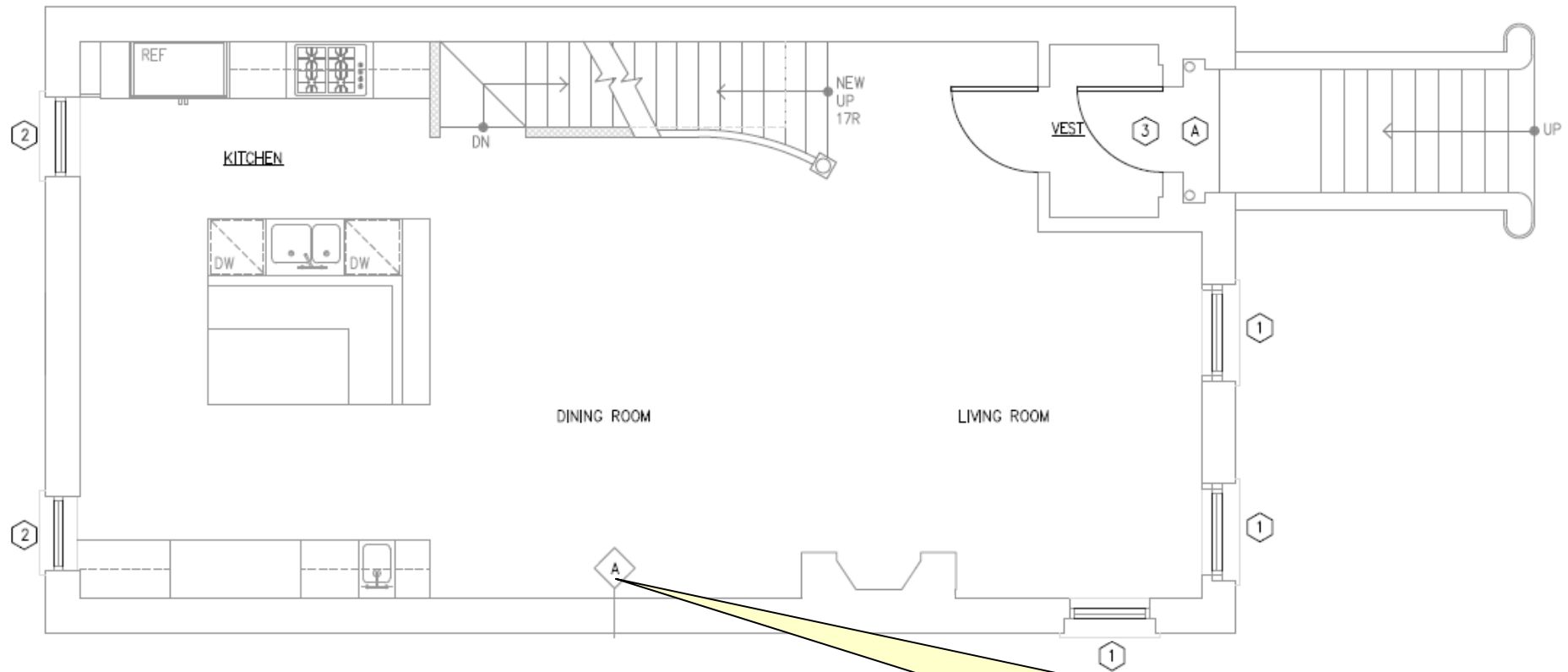

1st FLOOR PLAN



Fenestration types, door types, and exterior wall types should be clearly marked in the plans of the Supporting Documentation.

7. Submissions & Inspections

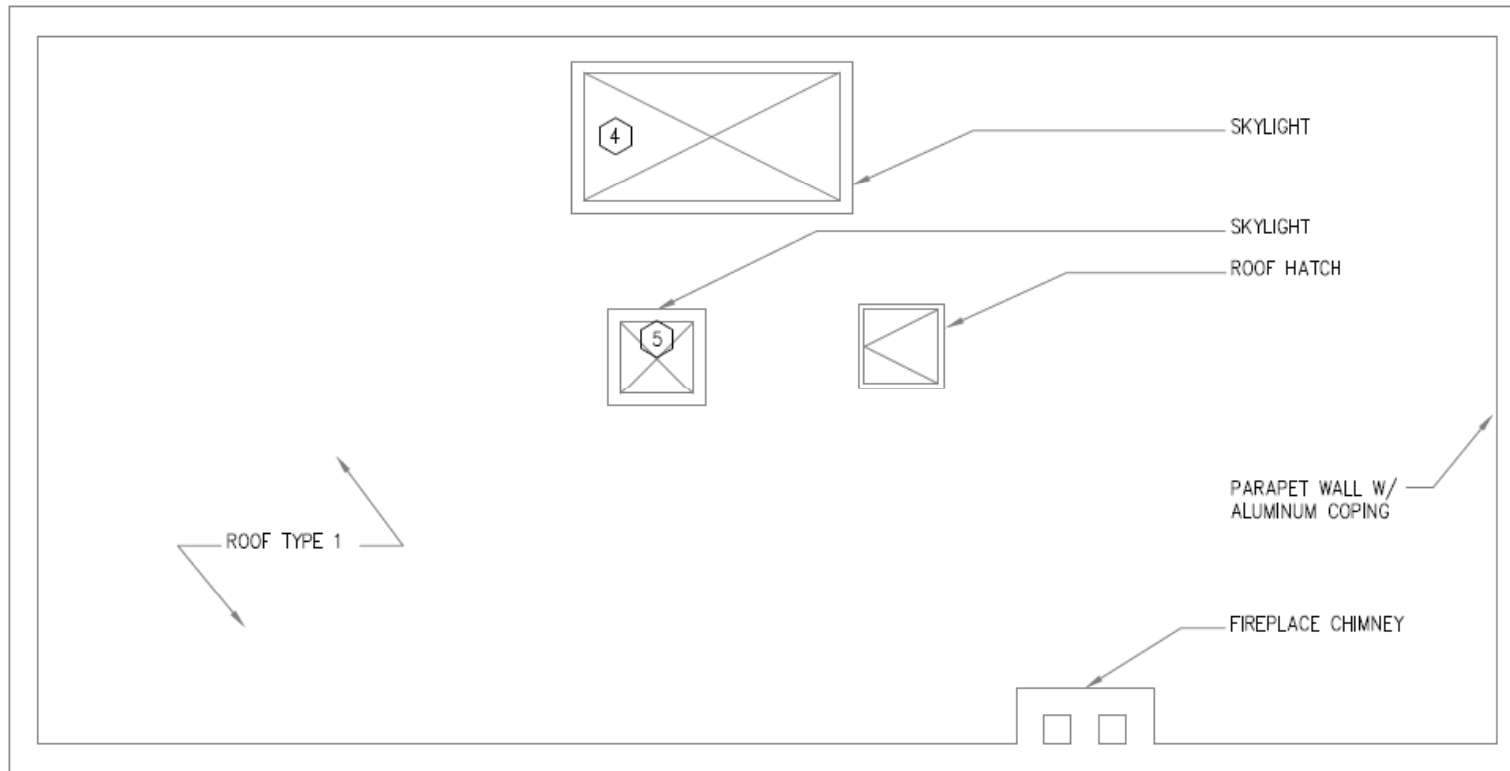

ROOF PLAN



7. Submissions & Inspections

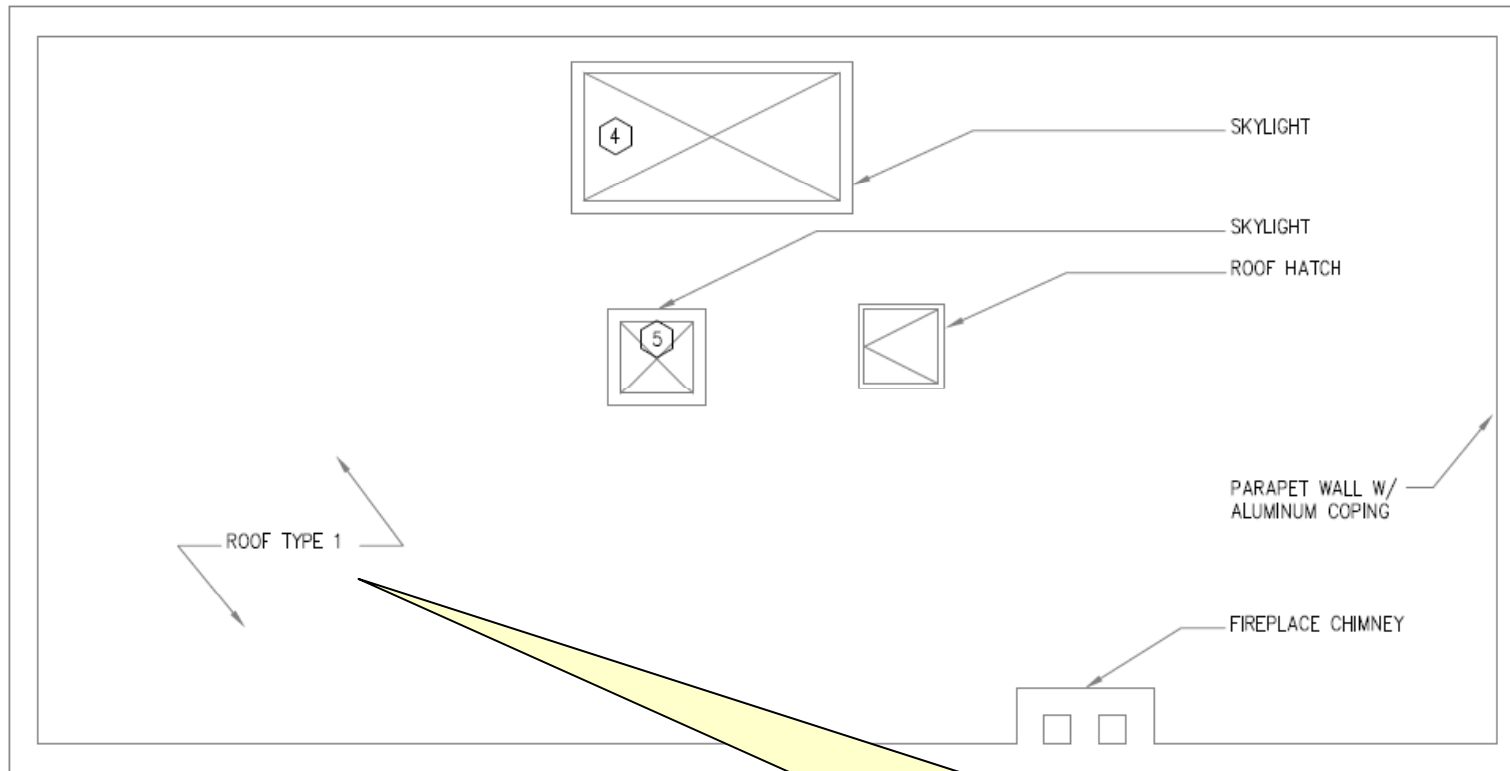

ROOF PLAN



Roof Types should be identified in the Roof Plans of the Supporting Documentation. If more than one type of roof assembly exists, show clear demarcation of the different roof assembly areas.

7. Submissions & Inspections



7. Submissions & Inspections



Fenestration types and door types should be clearly called out on the project elevations in the Supporting Documentation. These should be keyed into the submitted Window/Fenestration and Door Schedules, and from the corresponding Energy Analysis.

7. Submissions & Inspections



Wall sections and details in the Supporting Documentation should note materials/techniques to meet mandatory NYCECC Air Leakage requirements.

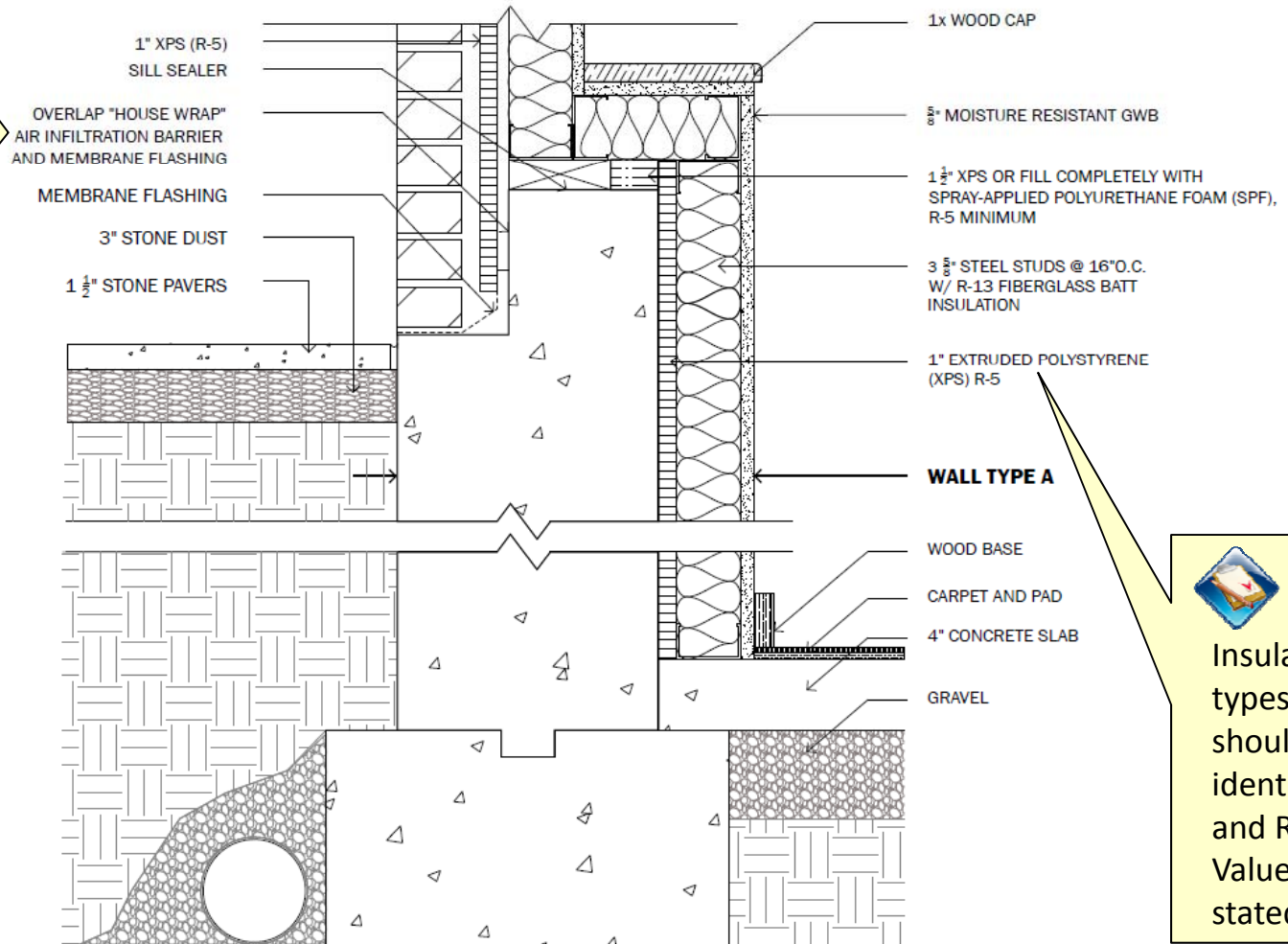

WALL DETAIL @ FOUNDATION / LOWER LEVEL



Insulation types should be identified and R-Values stated.

7. Submissions & Inspections



Wall sections and details in the Supporting Documentation should note materials/ techniques to meet mandatory NYCECC Air Leakage requirements.



All Wall Assembly Types should be identified, corresponding to those noted in the Plans and in the Energy Analysis.

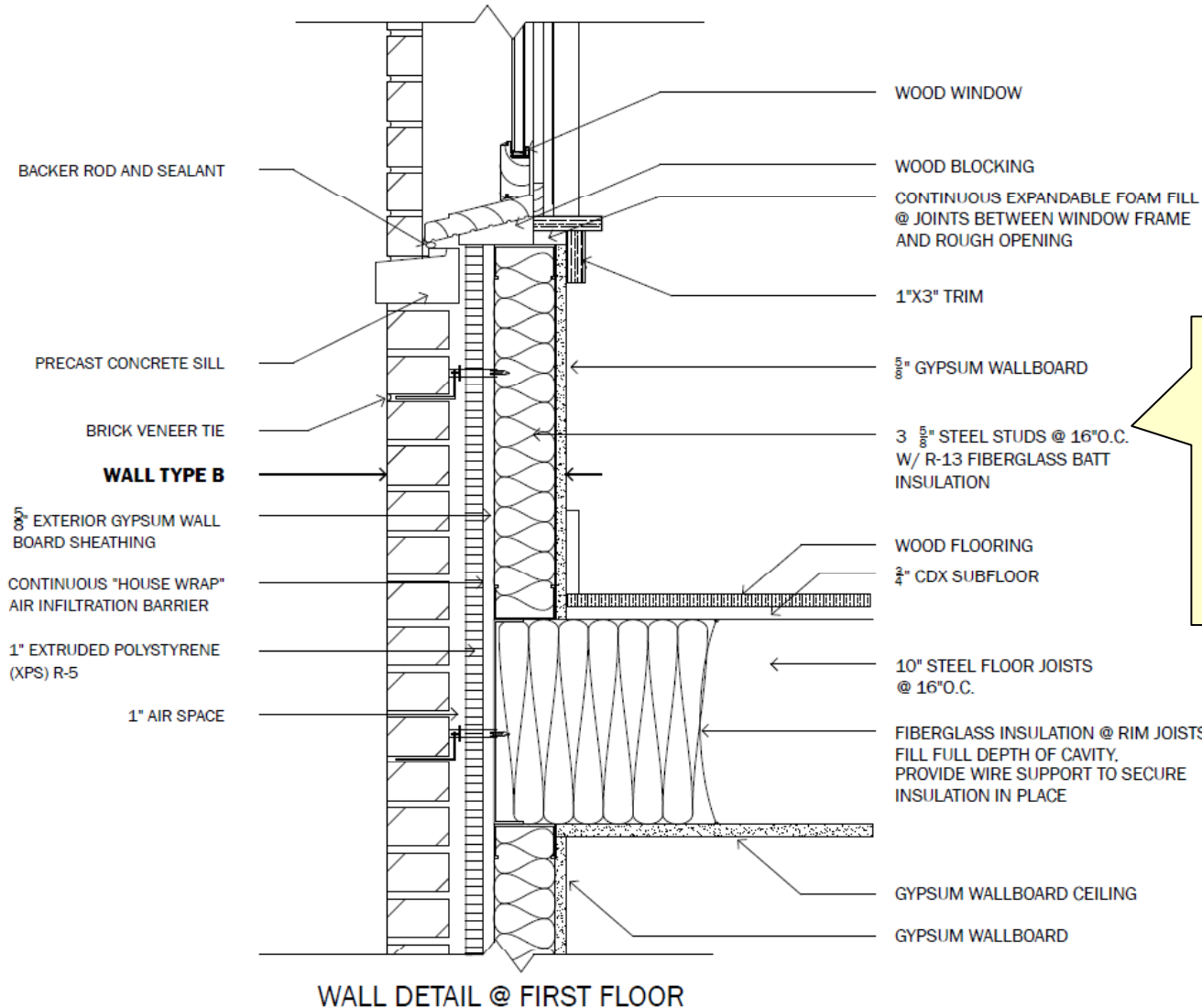

Insulation types should be identified and R-Values stated.

7. Submissions & Inspections

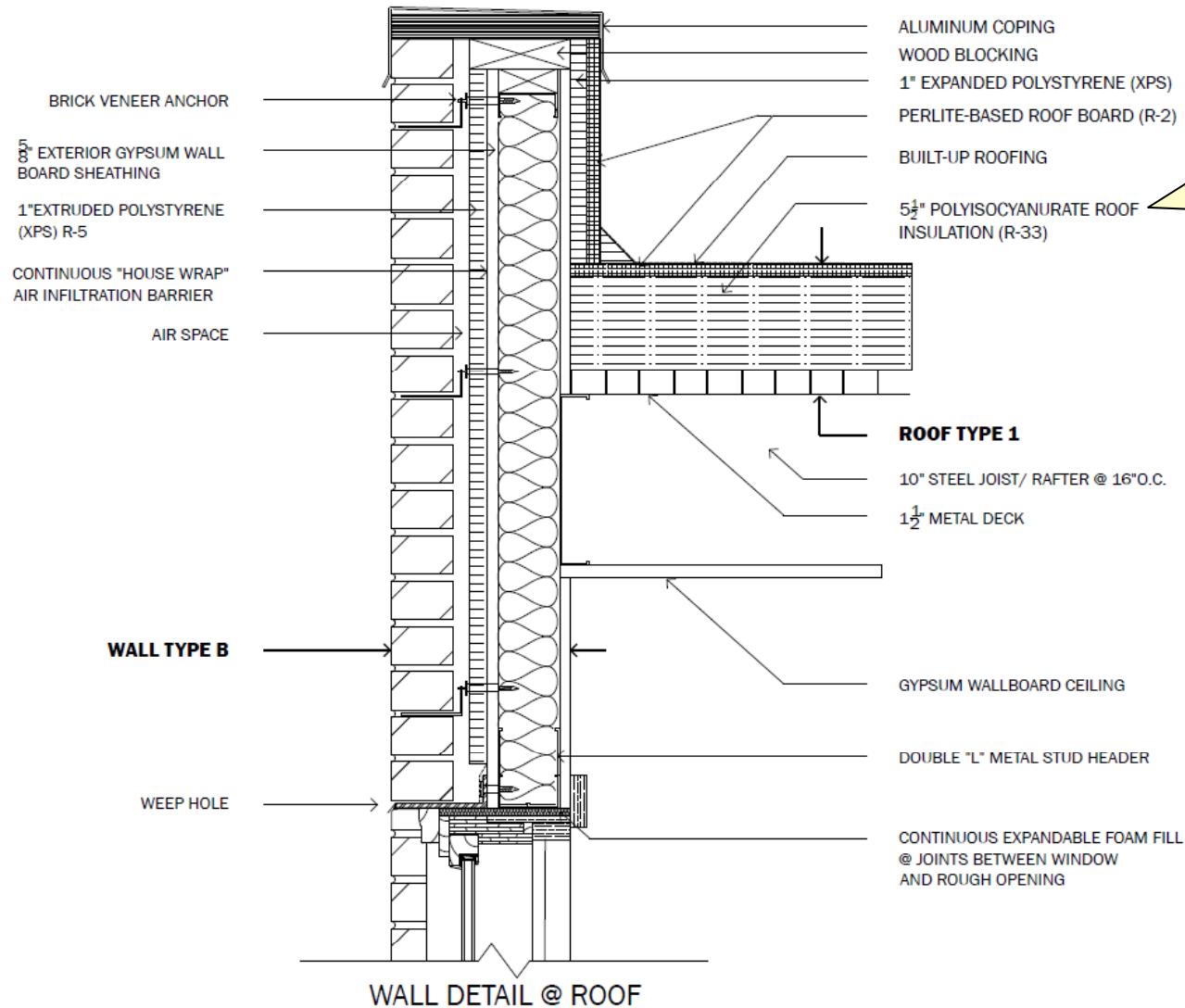

Wall sections and roof details in the Supporting Documentation should note the insulation type and state the R-Value.



7. Submissions & Inspections

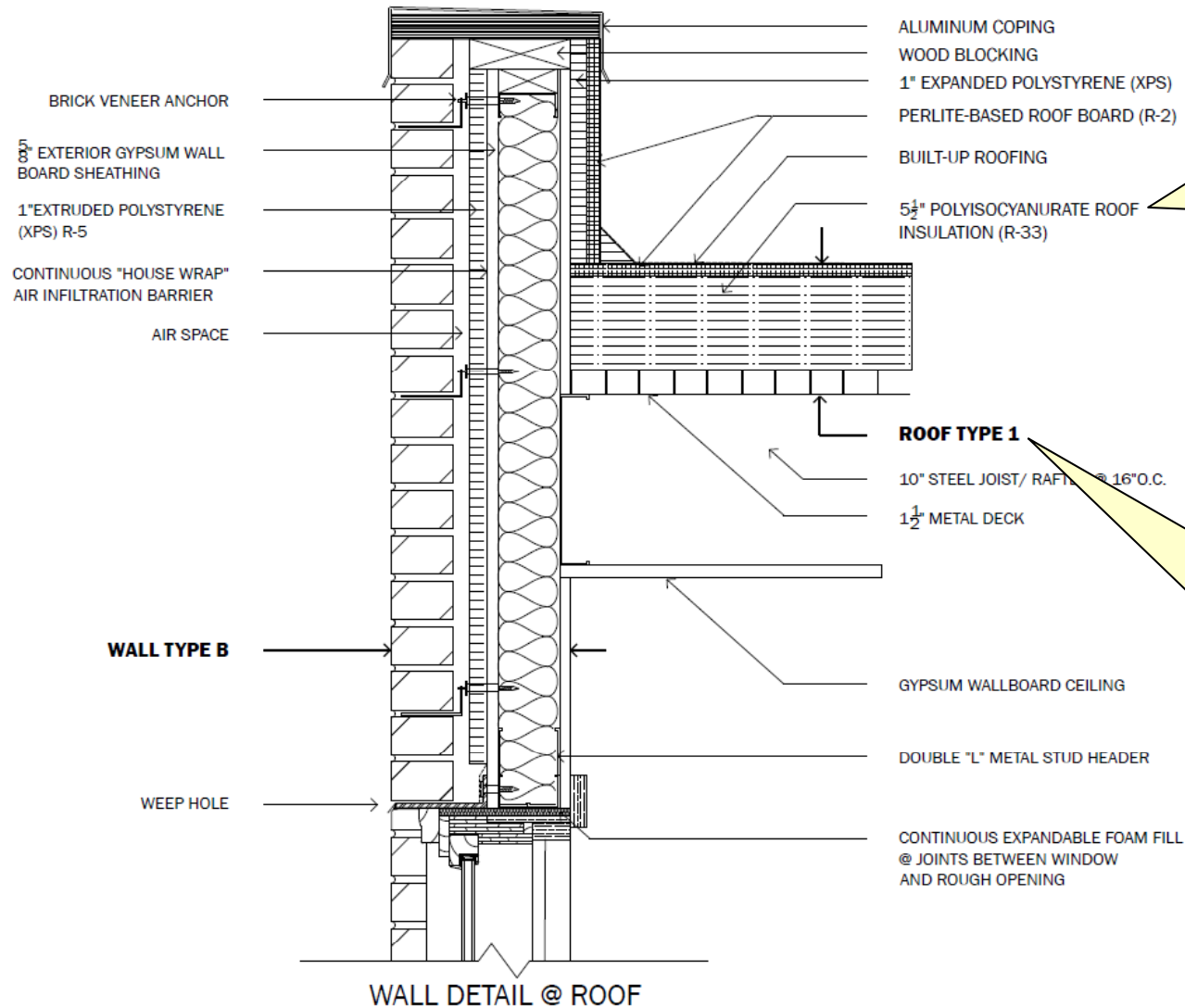

Wall sections and roof details in the Supporting Documentation should note the insulation type and state the R-Value.



Roof Assembly Types should be identified, corresponding to those noted in the Plans and Energy Analysis.

7. Submissions & Inspections

Window / Skylight Schedule								
Type	Description	R.O. / M.O.	Glass Type	U-Factor	Air Leakage	Manufacturer	Catalog #	Notes
1	Wood-Framed Dbl. Hung	3' - 0" x 7' - 0"	IGU, low-e, clear	0.33	0.30 cfm/SF	FSC Inc.	P100-3696	1
2	Wood-Framed Dbl. Hung	3' - 0" x 5' - 0"	IGU, low-e, clear	0.33	0.30 cfm/SF	FSC Inc.	P100-3660	1
3	Wood-Framed Fixed Transom	3' - 0" x 1' - 8"	IGU, low-e, clear	0.33	0.30 cfm/SF	FSC Inc.	P100-3620	1
4	Alum-Framed Fixed Skylight	4' - 0" W x 8' - 0" L	Triple Glazed, low-e, clear	0.70	≤ 0.10 cfm/SF	HLS Inc.	FS-4896	2, 3
5	Alum/ABS Framed Fixed Skylight	3' - 0" W x 3' - 0" L	IGU, low-e, tinted	0.54	≤ 0.10 cfm/SF	HLS Inc.	FS-3636	2, 3

Notes:

1. Air leakage: Provide flashing, window dams, expandable foam sealant, and caulking at rough opening/window frame joints to create a continuous air barrier with surrounding wall system.
2. Air leakage: Provide flashing, expandable foam sealant, and caulking at rough opening/skylight frame joints to create a continuous air barrier with surrounding roof system.
3. Manufacturer's air infiltration rates based on 6.24 psf (300 Pa) static pressure differential, tested per ASTM E 283.

Exterior Door Schedule								
Type	Description	R.O. / M.O.	Glass Type	U-Factor	Infiltration Value (cfm/SF)	Manufacturer	Catalog #	Notes
A	Wood/Glass French Door	3' - 0" x 8' - 0"	IGU, low-e, clear	0.31	0.30 cfm/SF	EJA Inc.	FR-2000 Series Custom Size	1
B	Solid Wood Raised Panel Door	3' - 0" x 6' - 8"	N/A	0.42	N/A*	CJA Inc.	WRP3680	1

Notes:

1. Air leakage: Provide flashing, expandable foam sealant, and caulking at rough opening/door frame joints to create a continuous air barrier with surrounding wall system.
- * Doors will be field-fitted with weatherstripping per ECC Section 502.4.1

7. Submissions & Inspections



Window / Skylight Schedule								
Type	Description	R.O. / M.O.	Glass Type	U-Factor	Air Leakage	Manufacturer	Catalog #	Notes
1	Wood-Framed Dbl. Hung	3' - 0" x 7' - 0"	IGU, low-e, clear	0.33	0.30 cfm/SF	FSC Inc.	P100-3696	1
2	Wood-Framed Dbl. Hung	3' - 0" x 5' - 0"	IGU, low-e, clear	0.33	0.30 cfm/SF	FSC Inc.	P100-3660	1
3	Wood-Framed Fixed Transom	3' - 0" x 1' - 8"	IGU, low-e, clear	0.33	0.30 cfm/SF	FSC Inc.	P100-3620	1
4	Alum-Framed Fixed Skylight	4' - 0" W x 8' - 0" L	Triple Glazed, low-e, clear	0.70	≤ 0.10 cfm/SF	HLS Inc.	FS-4896	2, 3
5	Alum/ABS Framed Fixed Skylight	3' - 0" W x 3' - 0" L	IGU, low-e, tinted	0.54	≤ 0.10 cfm/SF	HLS Inc.	FS-3636	2, 3

Notes:

1. Air leakage: Provide flashing, window dams, expandable foam sealant, and caulking at rough opening/window frame joints to create a continuous air barrier with surrounding wall system.
2. Air leakage: Provide flashing, expandable foam sealant, and caulking at rough opening/skylight frame joints to create a continuous air barrier with surrounding roof system.
3. Manufacturer's air infiltration rates based on 6.24 psf (300 Pa) static pressure differential, tested per ASTM E 283.

Exterior Door Schedule								
Type	Description	R.O. / M.O.	Glass Type	U-Factor	Infiltration Value (cfm/SF)	Manufacturer	Catalog #	Notes
A	Wood/Glass French Door	3' - 0" x 8' - 0"	IGU, low-e, clear	0.31	0.30 cfm/SF	EJA Inc.	FR-2000 Series Custom Size	1
B	Solid Wood Raised Panel Door	3' - 0" x 6' - 8"	N/A	0.42	N/A*	CJA Inc.	WRP3680	1

Notes:

1. Air leakage: Provide flashing, expandable foam sealant, and caulking at rough opening/door frame joints to create a continuous air barrier with surrounding wall system.
- * Doors will be field-fitted with weatherstripping per ECC Section 502.4.1



7. Submissions & Inspections



Schedules must include U-Factor and Air Leakage information.

Window / Skylight Schedule								
Type	Description	R.O. / M.O.	Glass Type	U-Factor	Air Leakage	Manufacturer	Catalog #	Notes
1	Wood-Framed Dbl. Hung		IGU, low-e, clear	0.33	0.30 cfm/SF	FSC Inc.	P100-3696	1
2	Wood-Framed Dbl. Hung	3' - 0" x 5' - 0"	IGU, low-e, clear	0.33	0.30 cfm/SF	FSC Inc.	P100-3660	1
3	Wood-Framed Fixed Transom	3' - 0" x 1' - 8"	IGU, low-e, clear	0.33	0.30 cfm/SF	FSC Inc.	P100-3620	1
4	Alum-Framed Fixed Skylight	4' - 0" W x 8' - 0" L	Triple Glazed, low-e, clear	0.70	≤ 0.10 cfm/SF	HLS Inc.	FS-4896	2, 3
5	Alum/ABS Framed Fixed Skylight	3' - 0" W x 3' - 0" L	IGU, low-e, tinted	0.54	≤ 0.10 cfm/SF	HLS Inc.	FS-3636	2, 3

Notes:

1. Air leakage: Provide flashing, window dams, expandable foam sealant, and caulking at rough opening/window frame joints to create a continuous air barrier with surrounding wall system.
2. Air leakage: Provide flashing, expandable foam sealant, and caulking at rough opening/skylight frame joints to create a continuous air barrier with surrounding wall system.
3. Manufacturer's air infiltration rates based on 6.24 psf (300 Pa) static pressure differential, tested per ASTM E 283.

Manufacturers and Catalog Numbers are optional for the NYCECC submission.

Exterior Door Schedule								
Type	Description	R.O. / M.O.	Glass Type	U-Factor	Infiltration Value (cfm/SF)	Manufacturer	Catalog #	Notes
A	Wood/Glass French Door	3' - 0" x 8' - 0"	IGU, low-e, clear	0.31	0.30 cfm/SF	EJA Inc.	FR-2000 Series Custom Size	1
B	Solid Wood Raised Panel Door	3' - 0" x 6' - 8"	N/A	0.42	N/A*	CJA Inc.	WRP3680	1

Notes:

1. Air leakage: Provide flashing, expandable foam sealant, and caulking at rough opening/door frame joints to create a continuous air barrier with surrounding wall system.
- * Doors will be field-fitted with weatherstripping per ECC Section 502.4.1



7. Submissions & Inspections

Joints, penetrations, and all other such openings in the building envelope that are sources of air leakage are sealed.

Recessed lights are either 1) Type IC rated with enclosures sealed/gasketed against leaks to the ceiling, or 2) Type IC rated and ASTM E283 labeled, or 3) installed inside an air-tight assembly with a 0.5" clearance from combustible materials and a 3" clearance from insulation.

Sunrooms:

Sunrooms that skylight U-factor requirements.

Materials Ident

Materials and

Insulation is in

Materials and

Manufacturer r

Insulation R-v

Duct Insulation

Ducts in uncond

Ducts in floor t

Duct Construct

Air handlers, fil

mechanically fi

All joints, seam

systems. Tape

Building fram

Automatic or g

Additional req

Mechanical Co

Temperature C

Thermostats e

cooling input f

Circulating Ser

Circulating ser

Circulating ser

system is not

Certificate:

A permanent c

U-factors; type

NOTES TO FIELD: (



REScheck Software Version 4.4.1
Inspection Checklist

Ceilings:

Roof Type 1: Steel Joist/Rafter, 16" o.c.:2x10
Comments: _____

Above-Grade Walls:

Exterior Wall Type A: Steel Frame, 16" o.c.:2x10
Comments: _____

Exterior Wall Type B: Steel Frame, 16" o.c.:2x10
Comments: _____

Windows:

Window 2: Wood Frame Double Pane with Low-E
For windows without labeled U-factors, describe the window.
#Panels: _____ Frame Type: _____
Comments: _____

Window 1: Wood Frame Double Pane with Low-E
For windows without labeled U-factors, describe the window.
#Panels: _____ Frame Type: _____
Comments: _____

Window 2: Wood Frame Double Pane with Low-E
For windows without labeled U-factors, describe the window.
#Panels: _____ Frame Type: _____
Comments: _____

Window 3: Wood Frame Double Pane with Low-E
For windows without labeled U-factors, describe the window.
#Panels: _____ Frame Type: _____
Comments: _____

Note: Up to 15 sq.ft. of glazed fenestration is exempt from U-factor requirements.

Skylights:

Window 4 - Skylight: Metal Frame with Thermal Break
#Panels: _____ Frame Type: _____
Comments: _____

Window 5 - Skylight: Other, U-factor: 0.540
#Panels: _____ Frame Type: _____
Comments: _____

Doors:

Door B: Solid, U-factor: 0.420
Comments: _____
Up to 40 sq.ft. of this door is exempt from U-factor requirements.

Door A: Glass, U-factor: 0.310
Comments: _____

Air Leakage:

Project Title: _____
Data filename: C:\Users\tdfogleman\Desktop\REScheck\



REScheck Software Version 4.4.1
Compliance Certificate

Energy Code: 2010 New York Energy Conservation
Construction Code
Location: Kings County, New York
Construction Type: Detached 1 or 2 Family
Glazing Area Percentage: 9%
Heating Degree Days: 4910
Climate Zone: 4

Construction Site: _____ Owner/Agent: _____ Designer/Contractor: _____

Compliance: Passes using UA trade-off
Compliance: **12.2% Better Than Code** Maximum UA: 500 Your UA: 439
The % Better or Worse Than Code Index reflects how close to compliance the house is based on code trade-off rules.
It DOES NOT provide an estimate of energy use or cost relative to a minimum-code home.

Assembly	Gross Area or Perimeter	Cavity R-Value	Cont. R-Value	Glazing or Door U-Factor	UA
Exterior Wall Type A: Steel Frame, 16" o.c.	1260	13.0	5.0		88
Window 2: Wood Frame Double Pane with Low-E	75			0.330	25
Door B: Solid	41			0.420	17
Exterior Wall Type B: Steel Frame, 16" o.c.	2513	13.0	5.0		173
Window 1: Wood Frame Double Pane with Low-E	210			0.330	69
Window 2: Wood Frame Double Pane with Low-E	30			0.330	10
Window 3: Wood Frame Double Pane with Low-E	5			0.330	2
Door A: Glass	24			0.310	7
Roof Type 1: Steel Joist/Rafter, 16" o.c.:2x10	823	0.0	35.0		21
Window 4 - Skylight: Metal Frame with Thermal Break Triple Pane	32			0.700	22
Window 5 - Skylight: Other	9			0.540	5

Compliance Statement: The proposed building design described here is consistent with the building plans, specifications, and other calculations submitted with the permit application. The proposed building has been designed to meet the 2010 New York Energy Conservation Construction Code requirements in REScheck Version 4.4.1 and to comply with the mandatory requirements listed in the REScheck Inspection Checklist.

Name - Title _____ Signature _____ Date _____



Project Title: _____ Report date: 03/10/11
Data filename: P:\Projects\NYC DOB Energy Code Compliance Study\2C_Training Modules\RWB_VEE_Residential\Residential_rev.rck Page 1 of



2010 New York Energy Conservation Construction Code Certificate

Item Rating	R-Value
-------------	---------

Roof / Roof 35.00

Foundation 18.00

Foundation 0.00

Work (unconditioned spaces): _____

Door Rating	U-Factor	SHGC
-------------	----------	------

Door 0.33 0.30

Door 0.70 0.30

Door 0.42 0.21

& Cooling Equipment	Efficiency
---------------------	------------

System: _____

System: _____

Heater: _____

Date: _____

Signature: _____

Date: _____

Project Title: _____

Data filename: _____

Report date: _____

Page 1 of _____

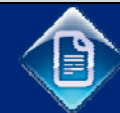

7. Submissions & Inspections

Joints, penetrations, and all other such openings in the building envelope that are sources of air leakage are sealed.

Recessed lights are either 1) Type IC rated with enclosures sealed/gasketed against leaks to the ceiling, or 2) Type IC rated and ASTM E283 labeled, or 3) installed inside an air-tight assembly with a 0.5" clearance from combustible materials and a 3" clearance from insulation.

Sunrooms:

Sunrooms that skylight U-factor requirements.

Materials Ident

Materials and

Insulation is in

Materials and

Manufacturer r

Insulation R-v

Duct Insulation

Ducts in uncor

Ducts in floor t

Duct Construct

Air handlers, fil

mechanically fi

All joints, seam

systems. Tape

Building fram

Automatic or g

Additional req

Mechanical Co

Temperature C

Thermostats e

cooling input f

Circulating Ser

Circulating ser

Circulating ser

system is not i

Certificate:

A permanent c

U-factors; type

NOTES TO FIELD: (



REScheck Software Version 4.4.1
Inspection Checklist

Ceilings:

Roof Type 1: Steel Joist/Rafter, 16" o.c.:2x10
Comments: _____

Above-Grade Walls:

Exterior Wall Type A: Steel Frame, 16" o.c.:2x10
Comments: _____

Exterior Wall Type B: Steel Frame, 16" o.c.:2x10
Comments: _____

Windows:

Window 2: Wood Frame Double Pane with Thermal Break
For windows without labeled U-factors, describe the window.
#Panes: _____ Frame Type: _____
Comments: _____

Window 1: Wood Frame Double Pane with Thermal Break
For windows without labeled U-factors, describe the window.
#Panes: _____ Frame Type: _____
Comments: _____

Window 2: Wood Frame Double Pane with Thermal Break
For windows without labeled U-factors, describe the window.
#Panes: _____ Frame Type: _____
Comments: _____

Window 3: Wood Frame Double Pane with Thermal Break
For windows without labeled U-factors, describe the window.
#Panes: _____ Frame Type: _____
Comments: _____

Note: Up to 15 sq.ft. of glazed fenestration is exempt from U-factor requirements.

Skylights:

Window 4 - Skylight: Metal Frame with Thermal Break
#Panes: _____ Frame Type: _____
Comments: _____

Window 5 - Skylight: Other, U-factor: 0.540
#Panes: _____ Frame Type: _____
Comments: _____

Doors:

Door B: Solid, U-factor: 0.420
Comments: _____
Up to 40 sq.ft. of this door is exempt from U-factor requirements.

Door A: Glass, U-factor: 0.310
Comments: _____

Air Leakage:

Project Title: _____
Data filename: C:\Users\fdogelman\Desktop\REScheck\



REScheck Software Version 4.4.1
Compliance Certificate

Energy Code: **2010 New York Energy Conservation Construction Code**
Location: **Kings County, New York**
Construction Type: **Detached 1 or 2 Family**
Glazing Area Percentage: **9%**
Heating Degree Days: **4910**
Climate Zone: **4**

Construction Site: _____ Owner/Agent: _____ Designer/Contractor: _____

Compliance: Passes using UA trade-off
Compliance: **12.2% Better Than Code** Maximum UA: **500** Your UA: **439**
The % Better or Worse Than Code Index reflects how close to compliance the house is based on code trade-off rules.
It DOES NOT provide an estimate of energy use or cost relative to a minimum-code home.

Assembly	Gross Area or Perimeter	Cavity R-Value	Cont. R-Value	Glazing or Door U-Factor	UA
Exterior Wall Type A: Steel Frame, 16" o.c.	1260	13.0	5.0		88
Window 2: Wood Frame Double Pane with Low-E	75			0.330	25
Door B: Solid	41			0.420	17
Exterior Wall Type B: Steel Frame, 16" o.c.	2513	13.0	5.0		173
Window 1: Wood Frame Double Pane with Low-E	210			0.330	69
Window 2: Wood Frame Double Pane with Low-E	30			0.330	10
Window 3: Wood Frame Double Pane with Low-E	5			0.330	2
Door A: Glass	24			0.310	7
Roof Type 1: Steel Joist/Rafter, 16" o.c.:2x10	823	0.0	35.0		21
Window 4 - Skylight: Metal Frame with Thermal Break Triple Pane	32			0.700	22
Window 5 - Skylight: Other	9			0.540	5

Compliance Statement: The proposed building design described here is consistent with the building plans, specifications, and other calculations submitted with the permit application. The proposed building has been designed to meet the 2010 New York Energy Conservation Construction Code requirements in REScheck Version 4.4.1 and to comply with the mandatory requirements listed in the REScheck Inspection Checklist.

Name - Title _____ Signature _____ Date _____



2010 New York Energy Conservation Construction Code Certificate

Item Rating	R-Value	U-Factor	SHGC
Roof	35.00		
Foundation	18.00		
Unconditioned spaces:	0.00		
Door Rating		0.33	0.30
		0.70	0.30
		0.42	0.21
Cooling Equipment		Efficiency	
System: _____		_____	
System: _____		_____	
Heater: _____		_____	
Date: _____			



Place clear image of REScheck Compliance Certificate on drawing and sign and seal at the title block of the sheet.





All Wall Types, Roof Types, Fenestration Types, and Door Types in the COMcheck analysis should use the same nomenclature as those shown in the Supporting Documentation.

Compliance: **Passes using UA trade-off**

Compliance: **12.2% Better Than Code** Maximum UA: **500** Your UA: **439**

The % Better or Worse Than Code index reflects how close to compliance the house is based on code trade-off rules. It DOES NOT provide an estimate of energy use or cost relative to a minimum-code home.

Assembly	Gross Area or Perimeter	Cavity R-Value	Cont. R-Value	Glazing or Door U-Factor	UA
Exterior Wall Type A: Steel Frame, 16" o.c.	1260	13.0	5.0		88
Window 2: Wood Frame:Double Pane with Low-E	75			0.330	25
Door B: Solid	41			0.420	17
Exterior Wall Type B: Steel Frame, 16" o.c.	2513	13.0	5.0		173
Window 1: Wood Frame:Double Pane with Low-E	210			0.330	69
Window 2: Wood Frame:Double Pane with Low-E	30			0.330	10
Window 3: Wood Frame:Double Pane with Low-E	5			0.330	2
Door A: Glass	24			0.310	7
Roof Type 1: Steel Joist/Rafter, 16" o.c.:2x10	823	0.0	35.0		21
Window 4 - Skylight: Metal Frame with Thermal Break:Triple Pane	32			0.700	22
Window 5 - Skylight: Other	9			0.540	5



7. Submissions & Inspections

	Inspection/Test	Frequency (minimum)	Reference Standard (See NYCECC Chapter 10) or Other Criteria	NYCECC or Other Citation
IB	Mechanical and Plumbing Inspections			
IB1	Fireplaces: Provision of combustion air and tight-fitting fireplace doors shall be verified by visual inspection.	Prior to final construction inspection	Approved construction documents; ANSI Z21.60 (see also MC 904), ANSI Z21.50	303.1.5; BC 2111; MC Chapters 7, 9; FGC Chapter 6
IB2	Outdoor Air Intake and Exhaust Dampers: Not less than 20% of installed automatic or gravity dampers, and a minimum of one of each type, shall be visually inspected and physically tested for proper operation.	Prior to final construction inspection	Approved construction documents	403.5, 403.7, 503
IB3	Equipment: Heating and cooling equipment shall be verified by visual inspection for proper sizing. Pool heaters and covers shall be verified by visual inspection.	Prior to final plumbing and construction inspection	ACCA Manual J; Approved construction documents, including energy analysis	403.6, 403.7, 403.9, 503
IB4	Controls: System controls shall be inspected to verify that each dwelling is provided with at least one individual programmable thermostat with capabilities as described in NYCECC 403.1.1, and that such controls are set and operate as specified in NYCECC 403.1.1. Controls for supplementary electric-resistance heat pumps shall be inspected to verify that such controls prevent supplemental heat operation when the heat pump compressor can meet the heating load. Controls for snow- and ice-melting systems and pools shall be inspected for proper operation. Not less than 20% or one of each control type, whichever is more, shall be inspected.	Prior to final electrical and construction inspection	Approved construction documents, including control system narratives	403.1, 403.4, 403.7, 403.8, 403.9, 503, 504
IB5	Duct and Piping Insulation and Duct Sealing: Installed duct and piping insulation shall be visually inspected to verify correct insulation placement and values. Ducts, air handlers, filter boxes and building cavities used as ducts shall be visually inspected for proper sealing.	Prior to closing ceilings and walls and prior to final construction inspection	Approved construction documents; RCNYS M1601.3.1	403.2.1, 403.2.2, 403.3, 403.4, 403.7, 503, 504; MC Section 603; 1RCNY §5000-01
IB6	Duct Leakage Testing: Where the air handler and/or some ductwork is in unconditioned space, duct-leakage testing shall be performed either after rough-in or post-construction to ensure compliance with NYCECC 403.2.2. Not less than 20% of such ductwork shall be tested.	Prior to closing ceilings and walls and prior to final construction inspection	Approved construction documents; ANSI/ASHRAE 152, ASTM E1554 Test Method A	403.2.2, 403.7, 503

7. Submissions & Inspections

	Inspection/Test	Frequency (minimum)	Reference Standard (See NYCECC Chapter 10) or Other Criteria	NYCECC or Other Citation
IB	Mechanical and Plumbing Inspections			
IB1	Fireplaces: Provision of combustion air and tight-fitting fireplace doors shall be verified by visual inspection.	Prior to final construction inspection	Approved construction documents; ANSI Z21.60 (see also MC 904), ANSI Z21.50	303.1.5; BC 2111; MC Chapters 7, 9; FGC Chapter 6
IB2	Outdoor Air Intake and Exhaust Dampers: Not less than 20% of installed automatic or gravity dampers, and a minimum of one of each type, shall be visually inspected and physically tested for proper operation.	Prior to final construction inspection	Approved construction documents	403.5, 403.7, 503
IB3	Equipment: Heating and cooling equipment shall be verified by visual inspection for proper sizing. Pool heaters and covers shall be verified by visual inspection.	Prior to final plumbing and construction inspection	ACCA Manual J; Approved construction documents, including energy analysis	403.6, 403.7, 403.9, 503
IB4	Controls: System controls shall be inspected to verify that each dwelling is provided with at least one individual programmable thermostat with capabilities as described in NYCECC 403.1.1, and that such controls are set and operate as specified in NYCECC 403.1.1. Controls for supplementary electric-resistance heat pumps shall be inspected to verify that such controls prevent supplemental heat operation when the heat pump compressor can meet the heating load. Controls for snow- and ice-melting systems and pools shall be inspected for proper operation. Not less than 20% or one of each control type, whichever is more, shall be inspected.	Prior to final electrical and construction inspection	Approved construction documents, including control system narratives	403.1, 403.4, 403.7, 403.8, 403.9, 503, 504
IB5	Duct and Piping Insulation and Duct Sealing: Installed duct and piping insulation shall be visually inspected to verify correct insulation placement and values. Ducts, air handlers, filter boxes and building cavities used as ducts shall be visually inspected for proper sealing.	Prior to closing ceilings and walls and prior to final construction inspection	Approved construction documents; RCNYS M1601.3.1	403.2.1, 403.2.2, 403.3, 403.4, 403.7, 503, 504; MC Section 603; 1RCNY §5000-01
IB6	Duct Leakage Testing: Where the air handler and/or some ductwork shall be performed either after rough-in or post-construction. 20% of such ductwork shall be tested.			



A Progress Inspections Table must be included in the Supporting Documentation, noting all applicable inspections to be performed based on the scope of work, plus Reference Standards and NYCECC citations.



 Inspection / Test	Frequency
Protection of exposed foundation insulation	Prior to backfill
Insulation placement and R-Values	As required to verify continuous enclosure while walls, ceilings and floors are open
Fenestration thermal values and product ratings	As required during installation
Fenestration product ratings for air leakage	As required during installation
Fenestration areas	Prior to final construction inspection
Air Sealing and Insulation – Visual Inspection	As required during envelope construction
Air Sealing and Insulation - Testing	Prior to final construction inspection
Fireplaces	Prior to final construction inspection
Outdoor Air Intake and Exhaust Dampers	Prior to final construction inspection
Equipment	Prior to final construction inspection





 Inspection / Test	Frequency
Controls	Prior to final electrical and construction inspection
Duct and Piping Insulation and Duct Sealing	Prior to closing ceilings and walls and prior to final construction inspection
Duct Leakage Testing	Prior to closing ceilings and walls and prior to final construction inspection
Electrical Metering	Prior to final electrical and construction inspection
Lighting in Dwelling Units	Prior to final electrical and construction inspection
Maintenance Information	Prior to sign-off or issuance of Certificate of Occupancy
Permanent Certificate	Prior to final plumbing, electrical and/or construction inspection as applicable



7. Submissions & Inspections

NYC
Buildings

TR8: Technical Report
Statement of Responsibility for
Energy Code Progress Inspections
This form must be typewritten

1 Location Information *Required for all applications.*

House No(s) Street Name

3 Energy Code Progress Inspection <i>Required for applications where Energy Code Compliance Progress Inspection is marked Yes on TR1</i>			3B Identification of Responsibilities	3C Certificate of Complete Inspections / Tests	3D Withdraw Responsibilities
3A ← Identification of Requirement			Initial & Date	Initial & Date	Initial & Date
Y	N	Progress Inspections	Table Reference in 1RCNY §5000-01(h) (1) and (2)		
<input type="checkbox"/>	<input type="checkbox"/>	Protection of foundation insulation	(IA1), (IIA1)		
<input type="checkbox"/>	<input type="checkbox"/>	Insulation placement and R values	(IA2), (IIA2)		
<input type="checkbox"/>	<input type="checkbox"/>	Fenestration thermal values and ratings	(IA3), (IIA3)		
<input type="checkbox"/>	<input type="checkbox"/>	Fenestration ratings for air leakage	(IA4), (IIA4)		
<input type="checkbox"/>	<input type="checkbox"/>	Fenestration areas	(IA5), (IIA5)		
<input type="checkbox"/>	<input type="checkbox"/>	Air sealing and insulation — visual	(IA6), (IIA6)		
<input type="checkbox"/>	<input type="checkbox"/>	Air sealing and insulation — testing	(IA7)		
<input type="checkbox"/>	<input type="checkbox"/>	Projection factors	(IIA7)		
<input type="checkbox"/>	<input type="checkbox"/>	Loading deck weather seals	(IIA8)		
<input type="checkbox"/>	<input type="checkbox"/>	Vestibules	(IIA9)		
<input type="checkbox"/>	<input type="checkbox"/>	Fireplaces	(IB1), (IIB1)		

<input type="checkbox"/>	Lighting controls	(IC5)		
<input type="checkbox"/>	Exit signs	(IC6)		
<input type="checkbox"/>	Tandem wiring	(IC7)		
<input type="checkbox"/>	Electrical motors	(IC8)		
<input type="checkbox"/>	Maintenance information	(ID1), (IID1)		
<input type="checkbox"/>	Permanent certificate	(ID2)		

01/11

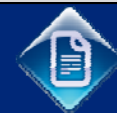

7. Submissions & Inspections

NYC
Buildings

TR8: Technical Report
Statement of Responsibility for
Energy Code Progress Inspection
This form must be typewritten

1 Location Information *Required for all applications.*

House No(s) Street Name

The applicant (R.A. or P.E.) defines the required progress inspections by checking “Y” or “N” in the left-hand column under section 3 of the TR8 form.

3 Energy Code Progress Inspections <i>Required for applications where Energy Code Compliance Progress Inspection is marked Yes on TR1</i>			3B Identification of Responsibilities	3C Certificate of Complete Inspections / Tests	3D Withdraw Responsibilities
Y	N	Progress Inspections	Table Reference in 1RCNY §5000-01(h) (1) and (2)	Initial & Date	Initial & Date
<input type="checkbox"/>	<input type="checkbox"/>	Protection of foundation insulation	(IA1), (IIA1)		
<input type="checkbox"/>	<input type="checkbox"/>	Insulation placement and R values	(IA2), (IIA2)		
<input type="checkbox"/>	<input type="checkbox"/>	Fenestration thermal values and ratings	(IA3), (IIA3)		
<input type="checkbox"/>	<input type="checkbox"/>	Fenestration ratings for air leakage	(IA4), (IIA4)		
<input type="checkbox"/>	<input type="checkbox"/>	Fenestration areas	(IA5), (IIA5)		
<input type="checkbox"/>	<input type="checkbox"/>	Air sealing and insulation — visual	(IA6), (IIA6)		
<input type="checkbox"/>	<input type="checkbox"/>	Air sealing and insulation — testing	(IA7)		
<input type="checkbox"/>	<input type="checkbox"/>	Projection factors	(IIA7)		
<input type="checkbox"/>	<input type="checkbox"/>	Loading deck weather seals	(IIA8)		
<input type="checkbox"/>	<input type="checkbox"/>	Vestibules	(IIA9)		
<input type="checkbox"/>	<input type="checkbox"/>	Fireplaces	(IB1), (IIB1)		

Prior to Permit, the designated Progress Inspector must initial and date each inspection they will be responsible for, and sign/seal under section 5 of the TR8 form. If multiple Progress Inspectors are involved in a project, each one must submit a signed/sealed TR8 for their scope of inspection services.

<input type="checkbox"/>	Lighting controls	(IC5)		
<input type="checkbox"/>	Exit signs	(IC6)		
<input type="checkbox"/>	Tandem wiring	(IC7)		
<input type="checkbox"/>	Electrical motors	(IC8)		
<input type="checkbox"/>	Maintenance information	(ID1), (IID1)		
<input type="checkbox"/>	Permanent certificate	(ID2)		

01/11

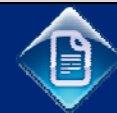

7. Submissions & Inspections

6 Inspection Applicant's Certification of Completion

- I have completed the items specified herein and certify the following (check one only):
- All work performed substantially conforms to approved construction documents and has been performed in accordance with applicable provisions of the New York City Energy Conservation Code and other designated rules and regulations.
 - All work performed substantially conforms to approved construction documents and has been performed in accordance with applicable provisions of the New York City Energy Conservation Code and other designated rules and regulations, except as indicated in the attached report.

I am aware of the additional sanctions imposed on false filings by §28-211.1.2 of the Administrative Code.

- Withdrawal of Applicant:** I am withdrawing responsibility for the items of progress inspections and/or tests indicated herein and herewith submit the results or status of the work performed to date.

Name (please print) _____

Signature _____

Date _____

P.E. / R.A. Seal (apply seal, then sign and date over seal)

7. Submissions & Inspections

NYC Buildings

TR8: Technical Report
Statement of Responsibility for
Energy Code Progress Inspections

This form must be typewritten

1 **Location Information** *Required for all applications.*

House No(s) _____ Street Name _____

Work on Floor(s) _____

6 Inspection Applicant's Certification of Completion

- I have completed the items specified herein and certify the following (check one only):
- All work performed substantially conforms to approved construction documents and has been performed in accordance with applicable provisions of the New York City Energy Conservation Code and other designated rules and regulations.
 - All work performed substantially conforms to approved construction documents and has been performed in accordance with applicable provisions of the New York City Energy Conservation Code and other designated rules and regulations report.

I am aware of the additional sanctions imposed on false filings by §28-211.1.2 of the Administrative Code.

- Withdrawal of Applicant:** I am withdrawing responsibility for the items of progress inspection and the results or status of the work performed to date.

Name (please print) _____

Signature _____

Date _____

P.E. / R.A. Seal *(apply seal, then sign and date over seal)*

Upon completion of the applicable inspections, the Progress Inspector initials and dates each inspection performed (column 3C). Any inspections assigned to the Progress Inspector that are not performed are addressed through column 3D (withdraw responsibilities). Final signatures and seals are provided in section 6 of the TR8 form.

7. Submissions & Inspections

NYC Administrative Code §28-116.2.3

- ❑ A record of all inspections shall be kept by the person performing the inspection.
 - ▶ The commissioner may require inspection reports to be filed with the department.
 - ▶ Records of inspections shall be maintained for a period of six years after sign-off, or for such other period of time as the commissioner may require
 - ▶ Records of inspections shall be made available to the DOB upon request.

EN2 Form

- ❑ This DOB form is signed by the progress inspector, certifying that the values in the last-approved Energy Analysis represent the respective values in the constructed building.



While a specific format is not stated, inspection records can include:

- ▶ Logs, reports, meeting minutes
- ▶ Photographs
- ▶ Annotated Drawings

7. Submissions & Inspections

NYC Buildings

EN2: As Built Energy Analysis

This form must be typewritten and submitted in person to the Certificate of Occupancy Division's Borough Office where energy analysis was reviewed.

Orient and affix SIS job number label here

1 Progress Inspector Information *Required for all applications.*

Last Name	First Name	Middle Initial
Business Name	Business Telephone	
Business Address	Business Fax	
City	State	Zip
License Type choose one: <input type="checkbox"/> P.E. <input type="checkbox"/> R.A.:	License Number	

2 Location Information *Required for all applications.*

3 As Built Information *P.E./R.A. responsible for progress inspections, choose one below and sign/seal.*

- The as-built conditions of the completed building conform to the originally approved energy analysis and do not require a revised energy analysis.
- The energy analysis has been revised according to one of the statements below:
 - Attached is a revised energy analysis, prepared, signed and sealed by the registered design professional who prepared the previously submitted and approved energy analysis. The as-built conditions of the completed building conform to this revised energy analysis.
 - The last revised energy analysis was submitted and approved as a post approval amendment on _____ (date). The as-built conditions of the completed building conform to this revised energy analysis.

sealed and submitted TWS.

Name (please print) _____

Signature _____ Date _____

P.E. / R.A. Seal (apply seal, then sign and date over seal)

01/11

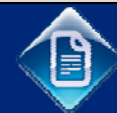

7. Submissions & Inspections

NYC Buildings EN2: As Built Energy Analysis
This form must be typewritten and submitted in person to the Certificate of Occupancy Division's Borough Office where energy analysis was reviewed.

Orient and affix BIS (job number label here)

1 Progress Inspector Information *Required for all applications.*

Last Name	First Name	Middle Initial
Business Name	Business Telephone	
Business Address	Business Fax	
City	State	Zip
License Type choose one: <input type="checkbox"/> P.E. <input type="checkbox"/> R.A.:	License Number	

2 Location Information *Required for all applications.*

3 As Built Information *P.E./R.A. responsible for progress inspections, choose one below and sign/seal.*

- The as-built conditions of the completed building conform to the originally approved energy analysis and do not require a revised energy analysis.
- The energy analysis has been revised according to one of the statements below:
 - Attached is a revised energy analysis, prepared, signed and sealed by the registered design professional who prepared the previously submitted and approved energy analysis. The as-built conditions of the completed building conform to this revised energy analysis.
 - The last revised energy analysis was submitted and approved as a post approval amendment on _____ (date). The as-built conditions of the completed building conform to this revised energy analysis.

sealed and submitted thru.

Name (please print) _____

Signature _____ Date _____

P.E. / R.A. Seal (apply seal, then sign and date over seal)

01/11

The Progress Inspectors and design applicants will need to coordinate to ensure that the as-built conditions and approved energy analysis are consistent. An as-built energy analysis update may be required.

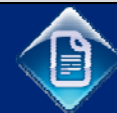



6. Resources

The resources below have been referenced in this module

Resource	Link 
Local Law 1 of 2011	http://www.nyc.gov/html/dob/downloads/pdf/ll1of2011.pdf
Local Law 48 of 2010	http://www.nyc.gov/html/dob/downloads/pdf/ll48of2010.pdf
1 RCNY §5000-01	http://www.nyc.gov/html/dob/downloads/rules/1_RCNY_5000-01.pdf
1 RCNY §101-07	http://www.nyc.gov/html/dob/downloads/rules/1_RCNY_101-07.pdf
Buildings Bulletins	http://www.nyc.gov/html/dob/html/reference/buildings_bulletin.shtml
EN1, EN2, and TR8 Forms	http://www.nyc.gov/html/dob/html/forms/forms_energy.shtml
REScheck/COMcheck	http://www.energycodes.gov/software.stm
PlaNYC	http://www.nyc.gov/html/planyc2030/html/home/home.shtml
New York City Construction Codes	http://www2.iccsafe.org/states/newyorkcity/

Questions on the NYCECC can be submitted to the DOB at:



EnergyCode@buildings.nyc.gov



12. Resources

Company or Individual	Slide Numbers
Samantha Modell	112
NFRC	54

