



Buildings

Zoning Compliance Improvements

Robert D. LiMandri
Commissioner
www.nyc.gov/buildings
Issuance: July 13, 2009

Zoning Diagram Guide

safety

service

integrity

Table of Contents

Objective	1
Site Plan Diagram Requirements	1
Axonometric Diagram Requirements	1
Format Requirements	1
Additional Zoning Requirements	2
Glossary	3
Site Plan Diagram Requirements	3-6
Axonometric Diagram Requirements	6-7
Sample Diagrams	8 -12

This guide is made available by the NYC Department of Buildings as a courtesy to the public. It does not represent all the filing requirements for any given application. Though every effort is made to continuously update this guide, it in no way supersedes, or otherwise substitutes for, the Building Code, Zoning Resolution or any other applicable rules, regulations or policies. If you notice any potential errors or inaccuracies in this guide, please send an e-mail to operationsredesign@buildings.nyc.gov.

Objective

To further increase transparency and compliance with zoning regulations, a new Zoning Diagram (ZD1) is required prior to approval with all initial filings for New Building and Alteration enlargement applications. All applicable Post Approval Amendments (PAAs) also require the ZD1. The ZD1 graphically summarizes the proposed zoning bulk, yards, and street plantings with detailed drawings, including site plans and projections describing vertical dimensions. Information regarding Variances and Special Permits, Use, and FAR is also required.

Site Plan Diagram Requirements

The items listed below must be included and notated as 'existing' or 'proposed.' Additionally, a citation of the appropriate Section of the New York City Zoning Resolution (ZR) is required for the **bold faced terms** (#1-4).

1. **Dimensioned Zoning Lot** (demonstrate residential lot width compliance as per ZR 23-32)
2. **Lot Coverage**
3. **Lot Area** (demonstrate residential lot area compliance as per ZR 23-32)
4. **Street Trees**
5. **Yards**
 - Front / Side / Rear** (notate Rear Yard of adjoining property if applicable)
6. Wide and Narrow Street
7. Zoning District(s), Overlays and Special Districts
8. Open Space / Plaza / Arcades
9. Curb Cuts / Splays / Curbs
10. Designated Parking Area (Driveway, Parking Areas, etc.)
11. Garages / Sheds
12. Decks
13. Building Footprint and/or Building Segments
14. Distance to Nearest Corner
15. Swimming Pools
16. Retaining Walls
17. Fences

Axonometric Diagram Requirements

Where applicable, the items listed below must be included, notated as 'existing' or 'proposed,' and represent the entire building bulk as an Axonometric Diagram. Additionally, a citation of the appropriate ZR Section is required for the following:

1. Dimensioned Building Height
2. Dimensioned Street Wall Heights and Setbacks
 - Dimensions required to maximum permissible limit
3. Permitted Obstructions
 - Maximum Building Envelope must be shown if the Permitted Obstruction affects the bulk of the building
4. Sky Exposure Plane

Note: Additionally, a Section Diagram may be included to more clearly depict the above requirements.

Title Block Requirements

Applicants must accurately answer the question regarding the reason for the ZD1 submission. The Title Block asks if the applicant is submitting the ZD1 to resolve objections stated in a Notice of Intent to Revoke issued under Rule 101-15. In addition, applicants must accurately and completely fill in the Location Information section and provide their signature and seal.

Format Requirements

The diagram must be submitted on the 11X17 ZD1 form provided on the Department's website. The items listed below are required. All content must be graphically clear and legible enabling the Department's document scanning function. No individual diagram (plan, axonometric, or section) may exceed one page.

1. North Arrow
2. Scale
3. Legend
4. 8 point (1/16") typeface, minimum

1 Applicant of Record

Complete and accurate information is required for all applications.

2 Additional Zoning Characteristics

Complete and accurate information is required for all applications. If any of the additional characteristics are not applicable, indicate a zero (0) on the appropriate line.

3 BSA and/or CPC Approvals for Subject Application

If a Board of Standards & Appeals (BSA) Variance or Special Permit has been granted for the application, include the Calendar Number (Cal. No.) and Authorizing Zoning Section. If a General City Law Waiver has been granted, include the Cal. No. and General City Law Section. If any other BSA approval has been granted, include the Cal. No.

If a City Planning Commission (CPC) Special Permit has been granted for the application, include the ULURP Number and Authorizing Zoning Section. If an Authorization or Certification has been granted, include the Application Number (App. No.) and Authorizing Zoning Section. If any other CPC approval has been granted, include the App. No.

4 Proposed Use and Floor Area

Complete and accurate information is required for all applications. Supplementary sheets may be included to accommodate additional floors. A sample is shown below.

- Floor Number may be a single floor or a group of floors with identical characteristics.
- Building Code Gross Floor Area must be included per line to accurately reflect other information.
- List only one Use Group per line.
- Zoning Floor Area must be included in the appropriate subsection: Residential, Community Facility, Commercial, or Manufacturing.
- FAR must be listed per floor or group of floors.

4 Proposed Floor Area <i>Required for all applications. One Use Group per line.</i>							
Floor Number	Building Code Gross Floor Area (sq.ft.)	Use Group	Zoning Floor Area (sq.ft.)				FAR
			Residential	Community Facility	Commercial	Manufacturing	
1	10,450	6	0	0	10,000	0	1
2	5225	4	0	5,000	0	0	.5
2	5225	6	0	0	5,000	0	.5
3-11	94,050	2	90,000	0	0	0	9
12	10,450	6	0	0	10,000	0	1
Totals	125,400		90,000	10,000	20,000	0	12
Total Zoning Floor Area						120,000	

Glossary

The following italicized terms are defined per Section 12-10 of the ZR, and illustrated as examples for this guide.

Site Plan Diagram

1. Dimensioned *Zoning Lot*

Lot or Zoning Lot : A Lot or a Zoning Lot is a tract of land comprising a single tax lot or two or more adjacent tax lots within a block.

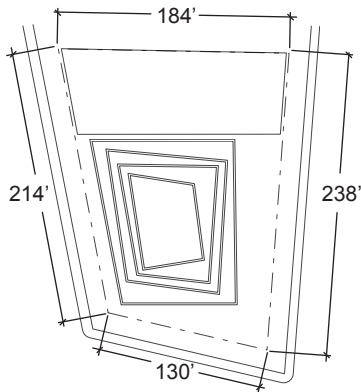

Dimensions are to be taken perpendicular to the lot line and notated. Demonstrate residential lot width compliance as per ZR 23-32.

2. *Building Footprint and/or Building Segments*

Building : A building is a structure that has one or more floors and a roof, is permanently affixed to the land and is bounded by either open areas or the lot lines of a zoning lot.

Building Segment : A building segment is a portion of a building where such building consists of two or more contiguous portions, each comprised of one or more dwelling units having a separate residential entrance or entrances serving only those dwelling units with such portion.

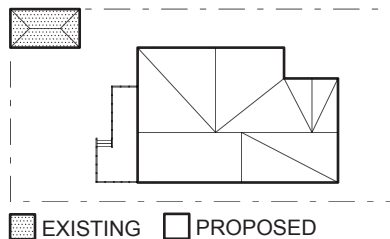

Building Footprints and Segments are to be easily identifiable and labeled as either existing or proposed in the Legend.

3. *Yards*

Yard : A yard is a required open area along the lot lines of a zoning lot which must be unobstructed from the lowest level to the sky, except for certain permitted obstructions.

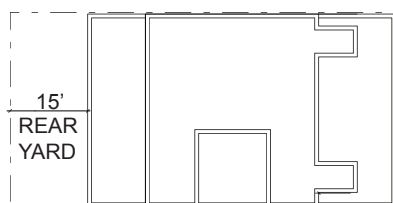

Yards are to be easily identifiable, either by dimensions or hatch, and cited with the appropriate ZR Section.

4. Wide and Narrow Streets

Wide Street : A street that is 75 feet or more in width. Certain bulk regulations applicable to wide streets are also applicable to developments on intersecting streets within 100 feet of a wide street.

Narrow Street : A street that is less than 75 feet wide.

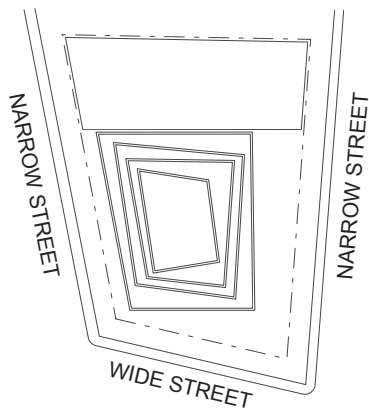

Street Widths are to be labeled.

5. Zoning District(s), Overlays and Special Districts

Zoning Districts : A zoning district is a mapped residential, commercial or manufacturing district with similar use, bulk and density regulations.

C1-6A
RESIDENTIAL DISTRICT EQUIVALENT
R7A QUALITY HOUSING PROGRAM

Zoning Districts are to be labeled, including any Overlays and Special Districts.

6. Street Trees

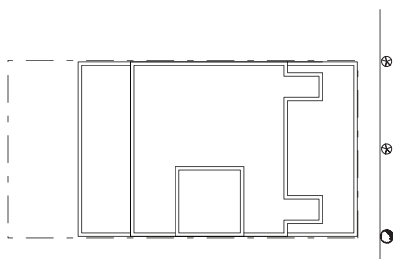

Street Trees are to be illustrated in the Plan Diagram, with the appropriate ZR Section citation.

7. Open Space / Plaza / Arcades

Open Space : Open Space is the part of a residential zoning lot (which may include courts and yards) that is open and unobstructed from its lowest level to the sky, except for specific permitted obstructions, and accessible to and usable by all persons occupying dwelling units on the zoning lot. Depending upon the district, the amount of required open space is determined by the open space ratio, minimum yard regulations or by maximum lot coverage.

Plaza : A plaza is an open area adjacent to a building and accessible to the public. It must generally be at the level of the sidewalk it adjoins and be unobstructed to the sky except for seating and other permitted obstructions. In certain high-density zoning districts, a floor area bonus is available for provision of a residential or urban plaza.

Arcades : An arcade is a continuous covered space that opens onto a street or a plaza. It is unobstructed to a height of not less than 12 feet, and must be accessible to the public at all times.

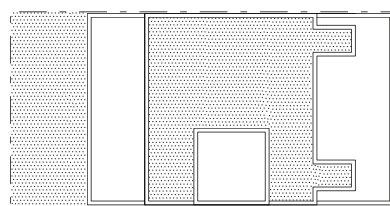

OPEN SPACE

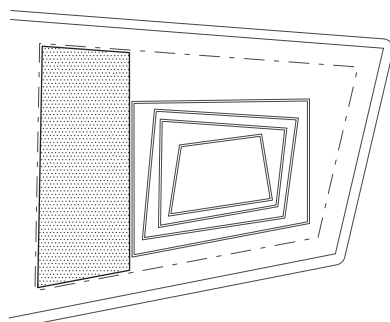

URBAN PLAZA

Open Space, Plazas and Arcades are to be easily identifiable, either by dimensions and labels or hatch, and defined in the Legend.

8. Curb Cuts / Splays / Curbs

Curb Cut : A curb cut is an inclined cut in the edge of a sidewalk to permit vehicular access to a driveway, garage, parking lot or loading dock. In lower- and medium-density residential districts, the maximum width for a curb cut is 10 feet; 15 feet for paired curb cuts. There must be a minimum width of 16 feet between curb cuts to ensure adequate curbside parking. See Diagram in #9 below.

9. Designated Parking Area (Driveway, Parking Areas, etc.)

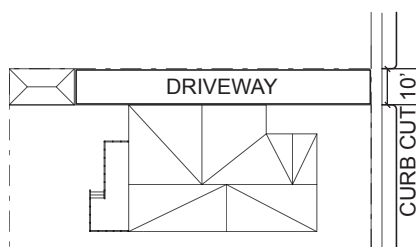

Curb Cuts and Designated Parking Areas are to be illustrated and labeled in the Plan Diagram. Additionally, Parking Areas are to be notated as either attended or unattended.

10. Garages / Sheds / Decks

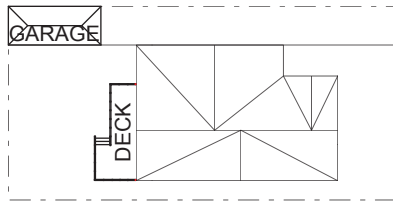

Garages and Decks are to be illustrated and labeled in the Plan Diagram.

Axonometric Diagram Requirements

1. Dimensioned *Building Height*

Building Height : The height of a building is measured from the curb level or base plane to the roof of the building (except for permitted obstructions).

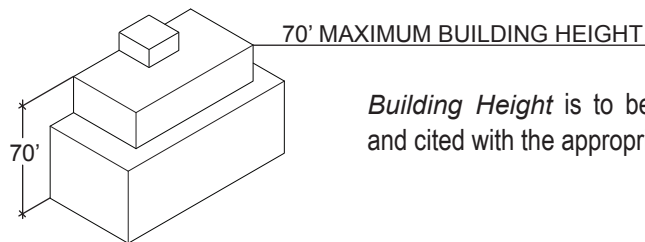

Building Height is to be dimensioned, labeled, and cited with the appropriate ZR Section.

2. Dimensioned *Street Wall Heights and Setbacks*

Street Wall : A street wall is a wall or portion of a wall of a building facing a street.

Setback : A setback is the portion of a building that is set back above the base height (or street wall or perimeter wall) before the total height of the building is achieved. The position of a building setback in height factor districts is controlled by sky exposure planes, and in contextual districts, by specified distances from street walls.

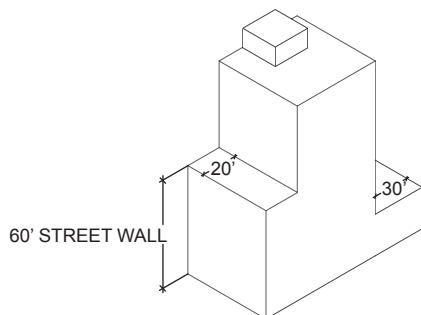

Street Walls and *Setbacks* are to be dimensioned, labeled, and cited with the appropriate ZR Section.

3. Permitted Obstructions

Permitted Obstruction : A permitted obstruction is a structure or object, such as a balcony, trellis, air conditioner, gutter or fence, that may be located within required open space or yards on a zoning lot, as specified in the Zoning Resolution. Certain structures on a roof, such as elevator bulkheads, water towers or parapets no higher than four feet are permitted obstructions and allowed to penetrate a height limit, setback area or sky exposure plane. See Diagram in #4 below.

4. Maximum Building Envelope

Building Envelope : A building envelope is the maximum three-dimensional space on a zoning lot within which a structure can be built, as permitted by applicable height, setback and yard controls.

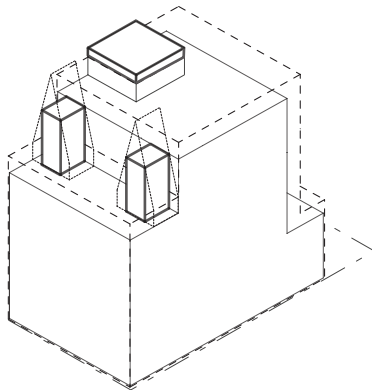

Maximum Building Envelope may be shown to better illustrate the overall building bulk. It is required to be shown where a *Permitted Obstruction* penetrates the *Maximum Building Envelope*. The appropriate ZR Section is to be cited.

5. Sky Exposure Plane

Sky Exposure Plane : A sky exposure plane is a virtual sloping plane that begins at a specified height and rises inward over the zoning lot at a ratio of vertical distance to horizontal distance set forth in district regulations. It is designed to provide light and air at street level, primarily in medium- and higher-density districts, and must not be penetrated by the building (except for permitted obstructions).

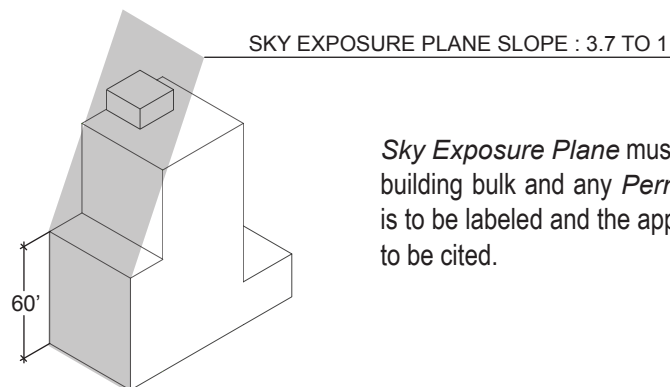

Sky Exposure Plane must be shown to illustrate building bulk and any *Permitted Obstruction*. It is to be labeled and the appropriate ZR Section is to be cited.

Sample Diagrams

The following pages contain examples of Zoning Diagrams. They are intended for reference use only, not as mandated drawing styles and layouts.

SITE PLAN DIAGRAM

1/16" = 1'0"



LOT COVERAGE %

AS PER ZR XX-XX

LOT AREA SQ. FT.

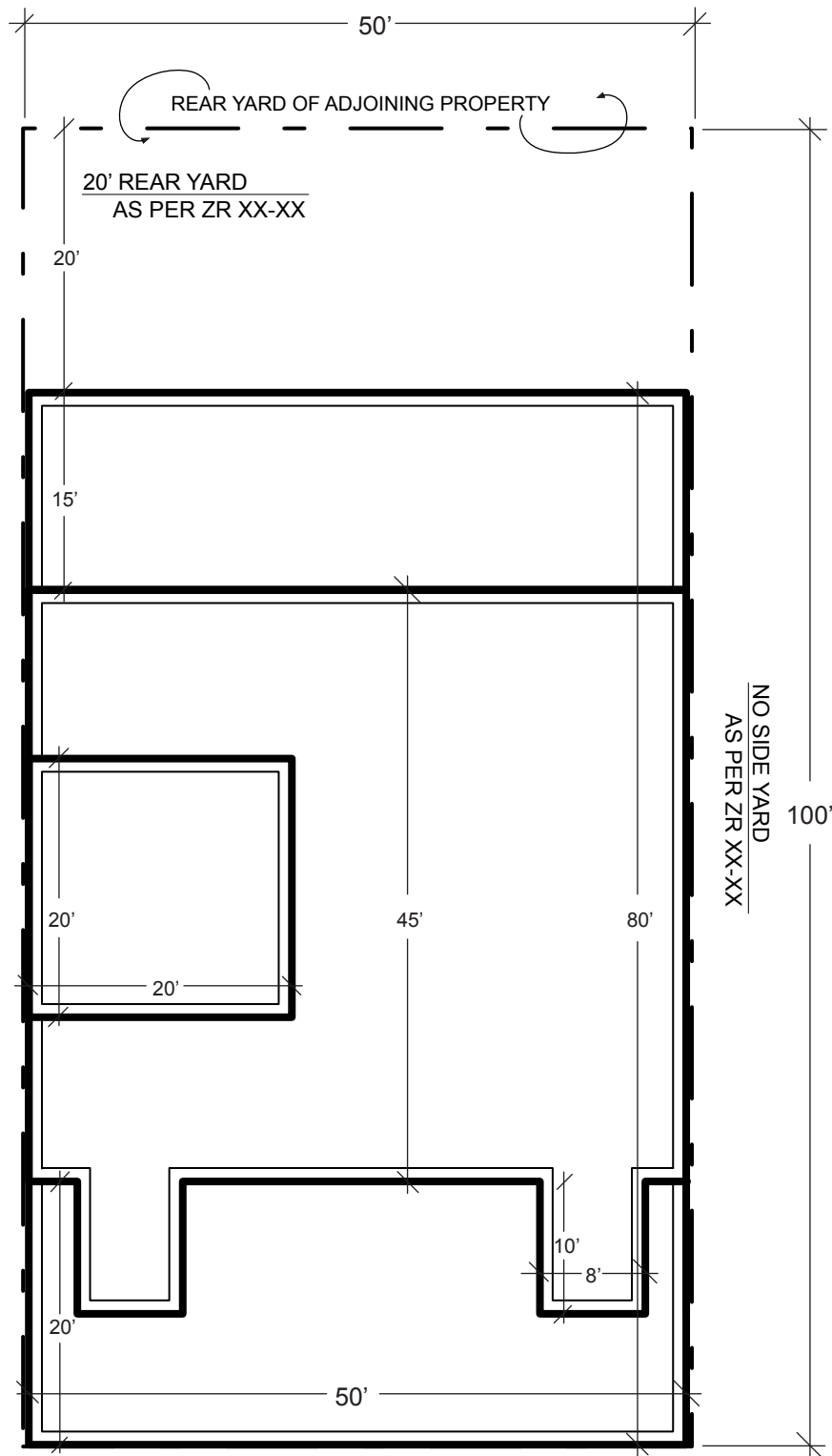

107' TO NEAREST CORNER

78' TO NEAREST CORNER

STREET TREE PLANTING
AS PER ZR XX-XX

NARROW STREET

LEGEND

C1-6A

RESIDENTIAL DISTRICT EQUIVALENT
R7A QUALITY HOUSING PROGRAM

PROPOSED BUILDING

ZONING LOT LINE

PERMITTED OBSTRUCTION

MAXIMUM BUILDING ENVELOPE

MAXIMUM DORMER ENVELOPE

EXISTING TREE

PROPOSED TREE

AXONOMETRIC DIAGRAM

NOT TO SCALE

REQUIRED SETBACKS

FRONT : AS PER ZR XX-XX
REAR : AS PER ZR XX-XX
SIDE : AS PER ZR XX-XX

PERMITTED OBSTRUCTIONS

AS PER ZR XX-XX
AS PER ZR XX-XX

56' STREET WALL

AS PER ZR XX-XX

74' BUILDING HEIGHT

AS PER ZR XX-XX

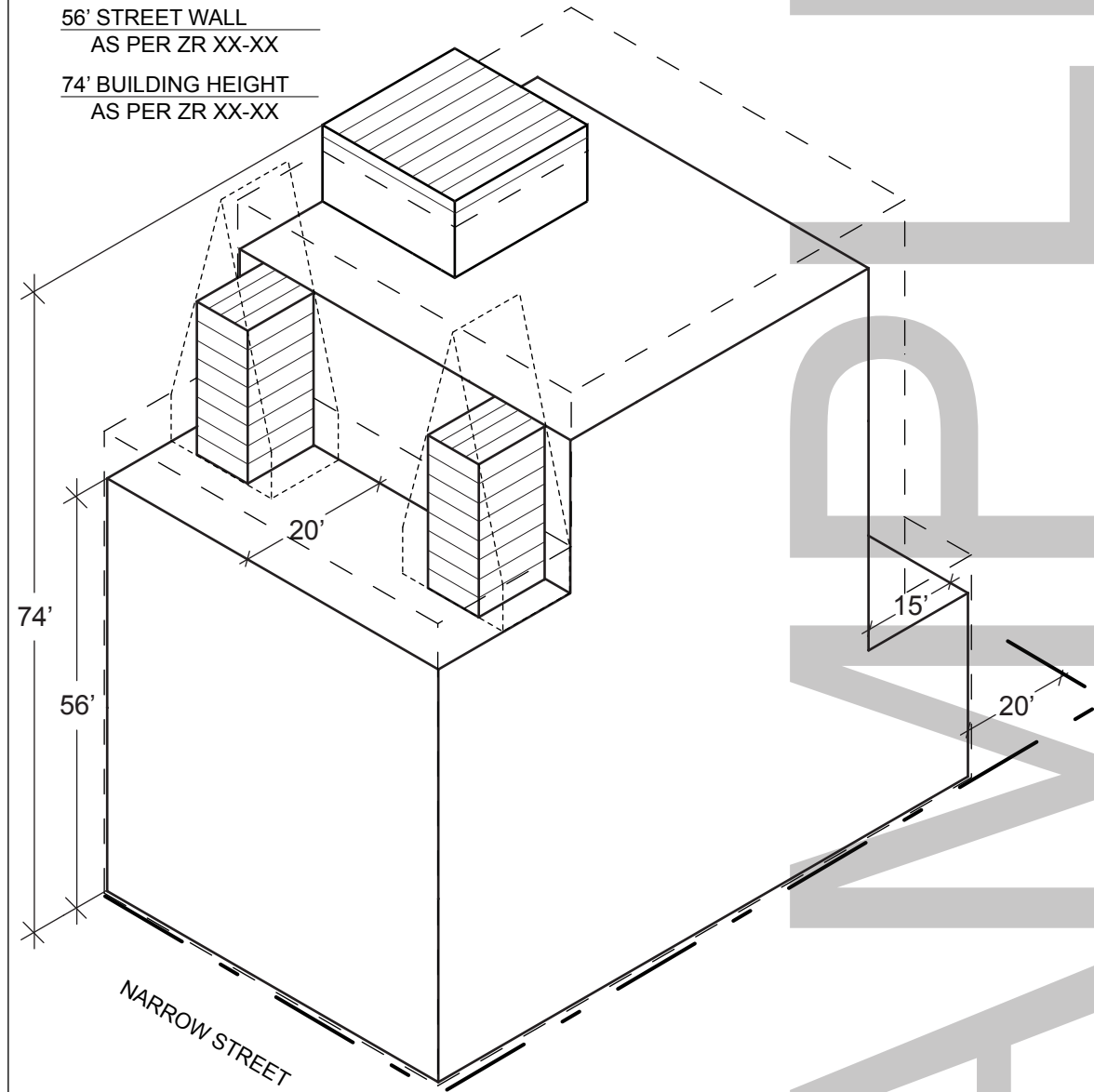

SECTION DIAGRAM

NOT TO SCALE

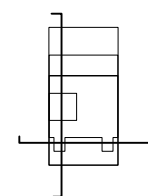

56' STREET WALL
AS PER ZR XX-XX

74' BUILDING HEIGHT
AS PER ZR XX-XX

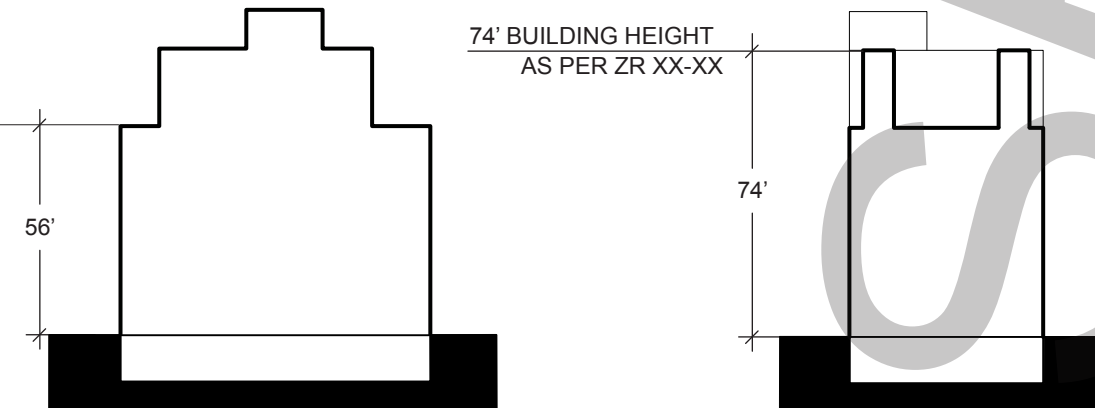

ZD1 Zoning Diagram

Must be typewritten.

Orient and affix BIS
job number label here

Submitted to resolve objections stated
in a notice of intent to revoke issued
pursuant to rule 101-15.

Yes No

Location Information

House No(s) _____
Street Name _____

Borough _____
Block _____
Lot _____
BIN _____

Falsification of any statement is a misde-
meanor and is punishable by a fine or im-
prisonment, or both. It is unlawful to give to
a city employee, or for a city employee to
accept, any benefit, monetary or otherwise,
either as a gratuity for properly performing
the job or in exchange for special consid-
eration. Violation is punishable by impris-
onment or fine or both. I understand that if
I am found after hearing to have knowingly
or negligently made a false statement or to
have knowingly or negligently falsified or
allowed to be falsified any certificate, form,
signed statement, application, report or
certification of the correction of a violation
required under the provisions of this code
or of a rule of any agency, I may be barred
from filing further applications or docu-
ments with the Department.

NAME (PLEASE PRINT)

SIGNATURE _____ DATE _____

P.E./A. SEAL (APPLY SEAL; SIGN AND DATE OVER SEAL)

Internal Use Only

BIS Doc # _____

PLAN EXAMINERS SIGN AND DATE

SITE PLAN DIAGRAM

1/16" = 1'0"



LOT COVERAGE %

AS PER ZR XX-XX

LOT AREA SQ. FT.

NO REAR YARD
AS PER ZR XX-XX

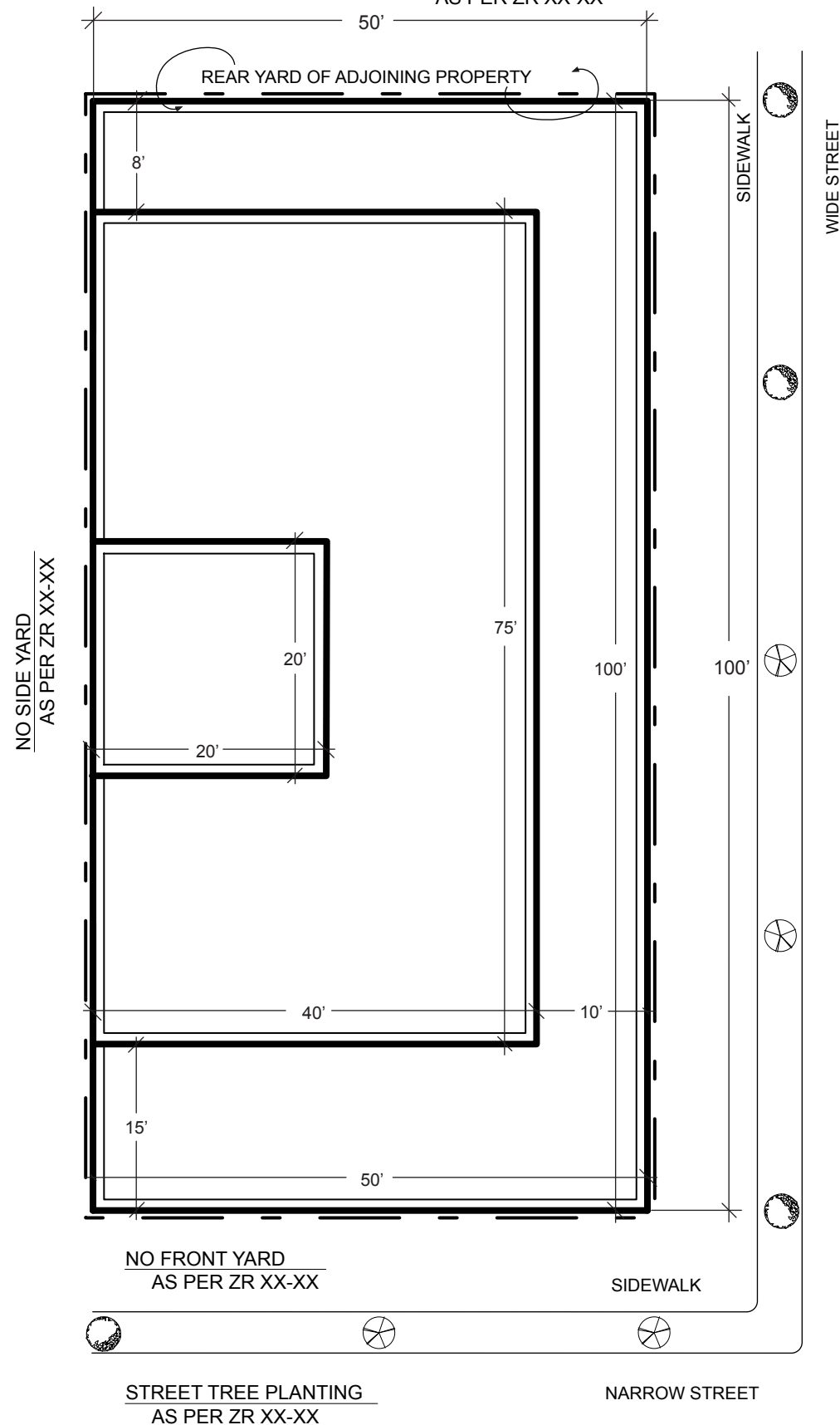

LEGEND

C4-2A

RESIDENTIAL DISTRICT EQUIVALENT
CONTEXTUAL DISTRICT
R6A QUALITY HOUSING PROGRAM



PROPOSED BUILDING

ZONING LOT LINE



EXISTING TREE



PROPOSED TREE

SECTION DIAGRAMS

NOT TO SCALE

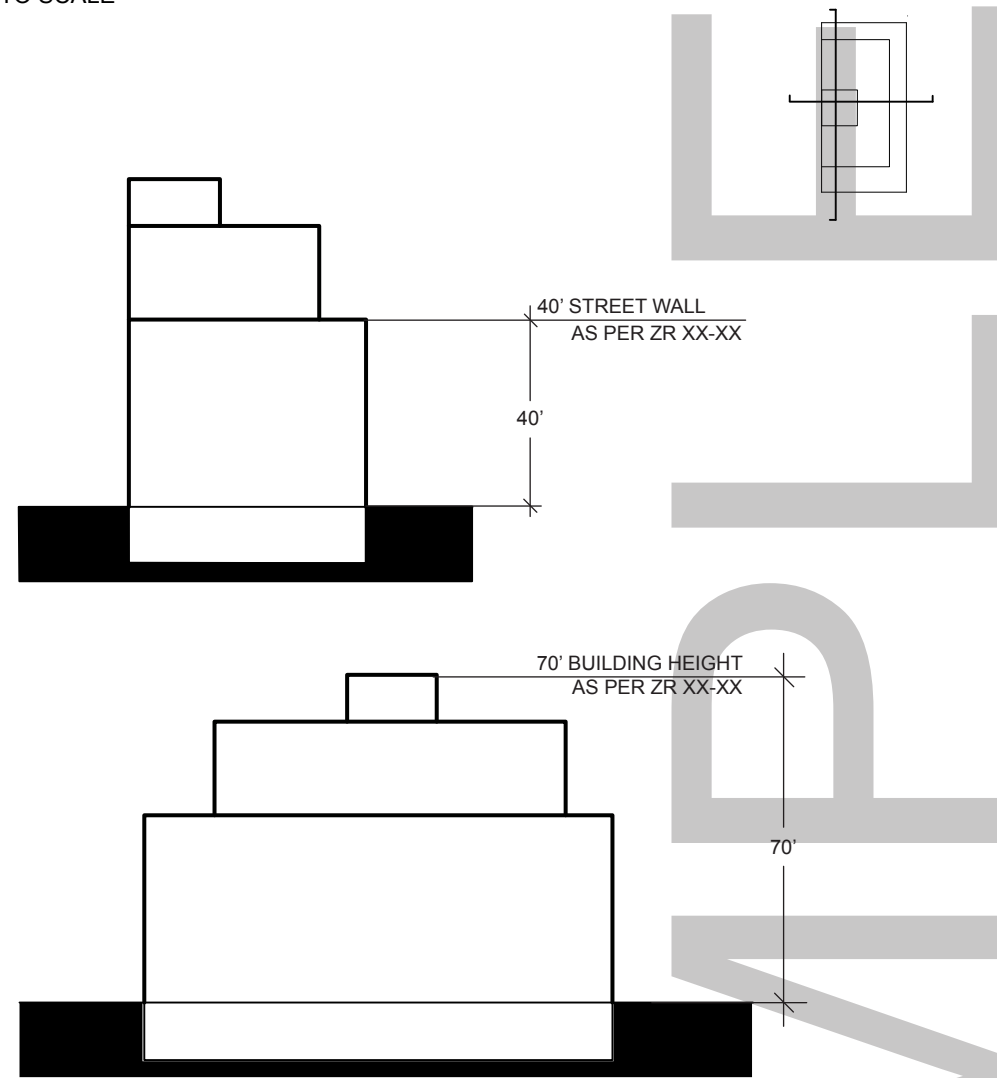

AXONOMETRIC DIAGRAM

NOT TO SCALE

REQUIRED SETBACKS

FRONT : AS PER ZR XX-XX

REAR : AS PER ZR XX-XX

SIDE : AS PER ZR XX-XX

40' STREET WALL

AS PER ZR XX-XX

70' BUILDING HEIGHT

AS PER ZR XX-XX

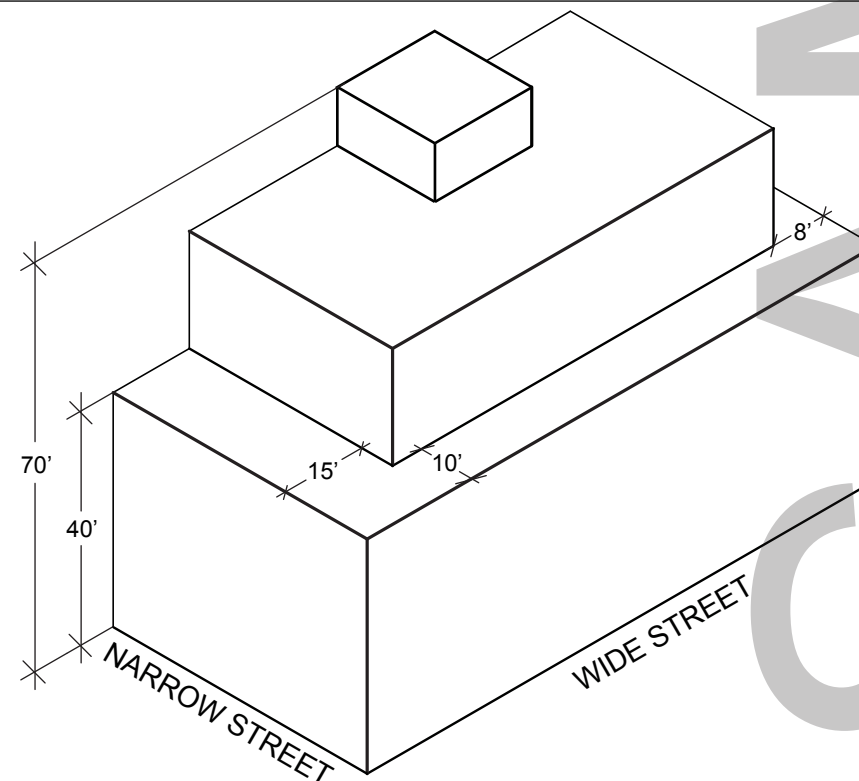

ZD1 Zoning Diagram

Must be typewritten.

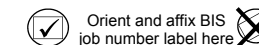

Orient and affix BIS
job number label here

Submitted to resolve objections stated
in a notice of intent to revoke issued
pursuant to rule 101-15.

Yes No

Location Information

House No(s) _____

Street Name _____

Borough _____

Block _____

Lot _____

BIN _____

Falsification of any statement is a misde-
meanor and is punishable by a fine or im-
prisonment, or both. It is unlawful to give to
a city employee, or for a city employee to
accept, any benefit, monetary or otherwise,
either as a gratuity for properly performing
the job or in exchange for special consid-
eration. Violation is punishable by impris-
onment or fine or both. I understand that if
I am found after hearing to have knowingly
or negligently made a false statement or to
have knowingly or negligently falsified or
allowed to be falsified any certificate, form,
signed statement, application, report or
certification of the correction of a violation
required under the provisions of this code
or of a rule of any agency, I may be barred
from filing further applications or docu-
ments with the Department.

NAME (PLEASE PRINT) _____

SIGNATURE _____ DATE _____

P.E./R.A. SEAL (APPLY SEAL; SIGN AND DATE OVER SEAL)

Internal Use Only

BIS Doc # _____

PLAN EXAMINERS SIGN AND DATE

SITE PLAN DIAGRAM

1/16" = 1'0"



LOT AREA SQ.FT.

LOT COVERAGE %
AS PER ZR XX-XX

NO REAR YARD
AS PER ZR XX-XX

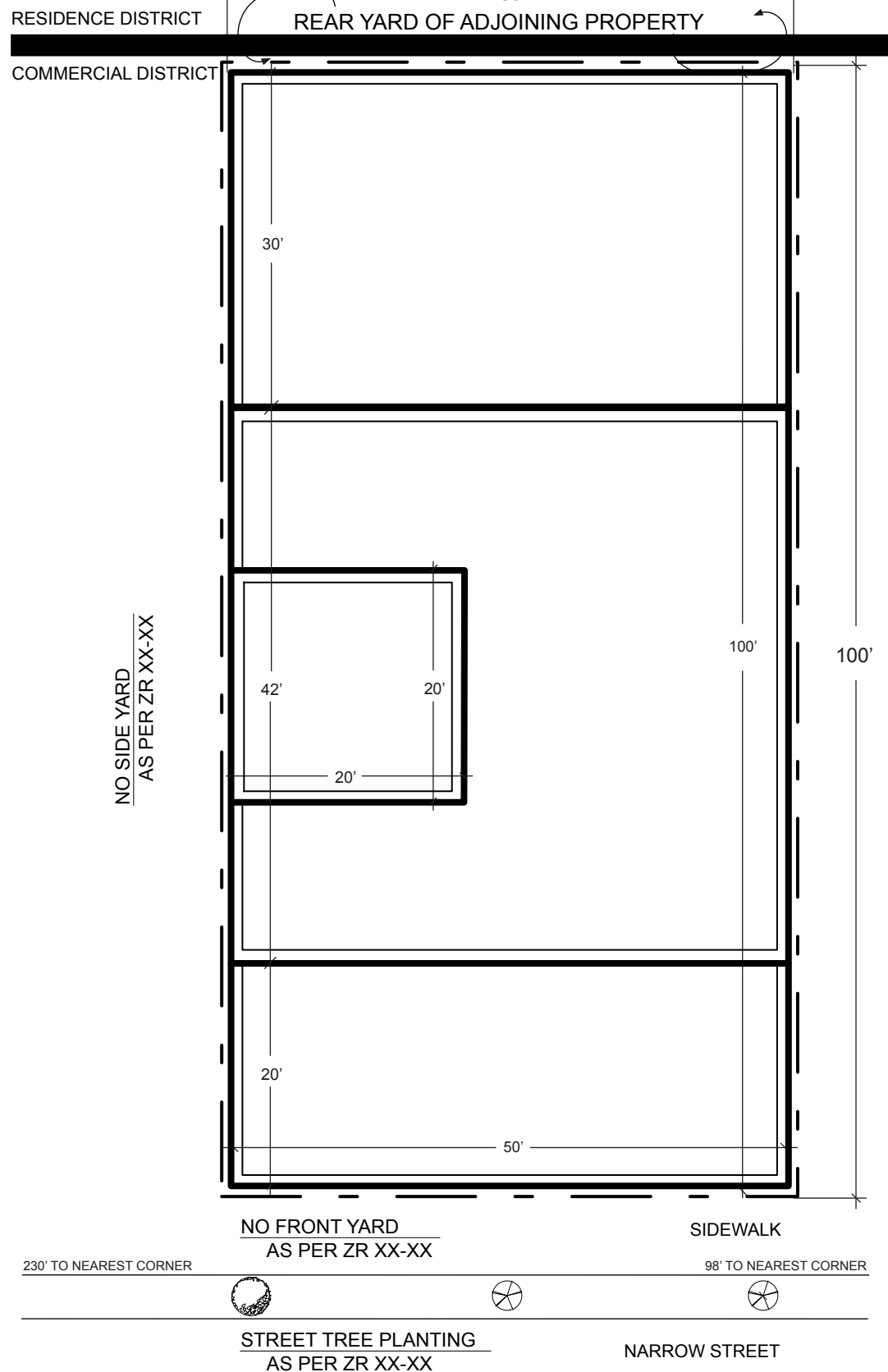

LEGEND

C4-4
RESIDENTIAL DISTRICT EQUIVALENT R7

PROPOSED BUILDING

ZONING LOT LINE

DISTRICT BOUNDARY

SKY EXPOSURE PLANE

EXISTING TREE

PROPOSED TREE

SECTION DIAGRAM

NOT TO SCALE

SKY EXPOSURE PLANE SLOPE : 3.7 TO 1
AS PER ZR XX-XX

60' STREET WALL
AS PER ZR XX-XX

60'

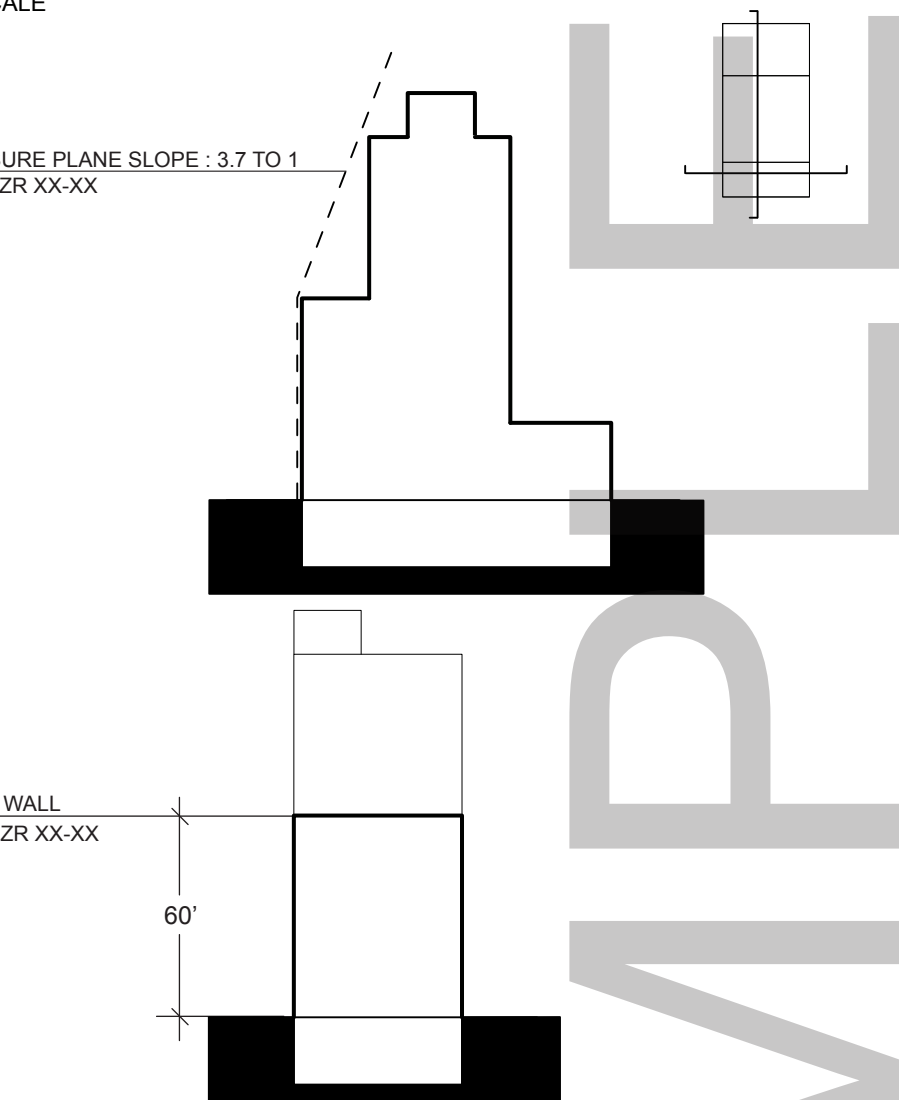

AXONOMETRIC DIAGRAM

NOT TO SCALE

REQUIRED SETBACKS
FRONT : AS PER ZR XX-XX
REAR : AS PER ZR XX-XX
SIDE : AS PER ZR XX-XX

60' STREET WALL
AS PER ZR XX-XX

SKY EXPOSURE PLANE
AS PER ZR XX-XX

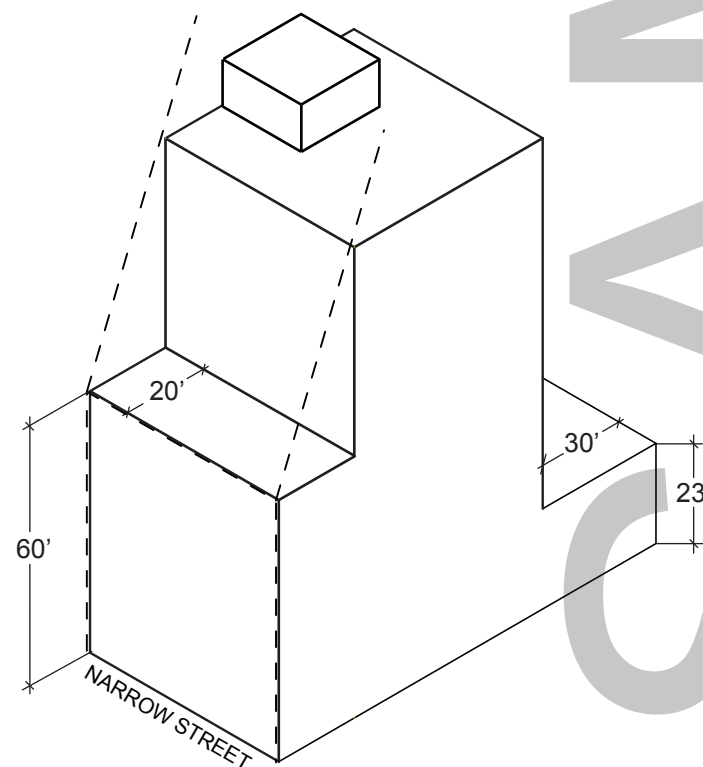

ZD1 Zoning Diagram

Must be typewritten.

Orient and affix BIS
job number label here

Submitted to resolve objections stated
in a notice of intent to revoke issued
pursuant to rule 101-15.

Yes No

Location Information

House No(s) _____
Street Name _____

Borough _____
Block _____
Lot _____
BIN _____

Falsification of any statement is a misde-
meanor and is punishable by a fine or im-
prisonment, or both. It is unlawful to give to
a city employee, or for a city employee to
accept, any benefit, monetary or otherwise,
either as a gratuity for properly performing
the job or in exchange for special consid-
eration. Violation is punishable by impris-
onment or fine or both. I understand that if
I am found after hearing to have knowingly
or negligently made a false statement or to
have knowingly or negligently falsified or
allowed to be falsified any certificate, form,
signed statement, application, report or
certification of the correction of a violation
required under the provisions of this code
or of a rule of any agency, I may be barred
from filing further applications or docu-
ments with the Department.

NAME (PLEASE PRINT)

SIGNATURE _____ DATE _____

P.E./A. SEAL (APPLY SEAL; SIGN AND DATE OVER SEAL)

Internal Use Only

BIS Doc # _____

PLAN EXAMINERS SIGN AND DATE

SITE PLAN DIAGRAM

1/32" = 1'0"

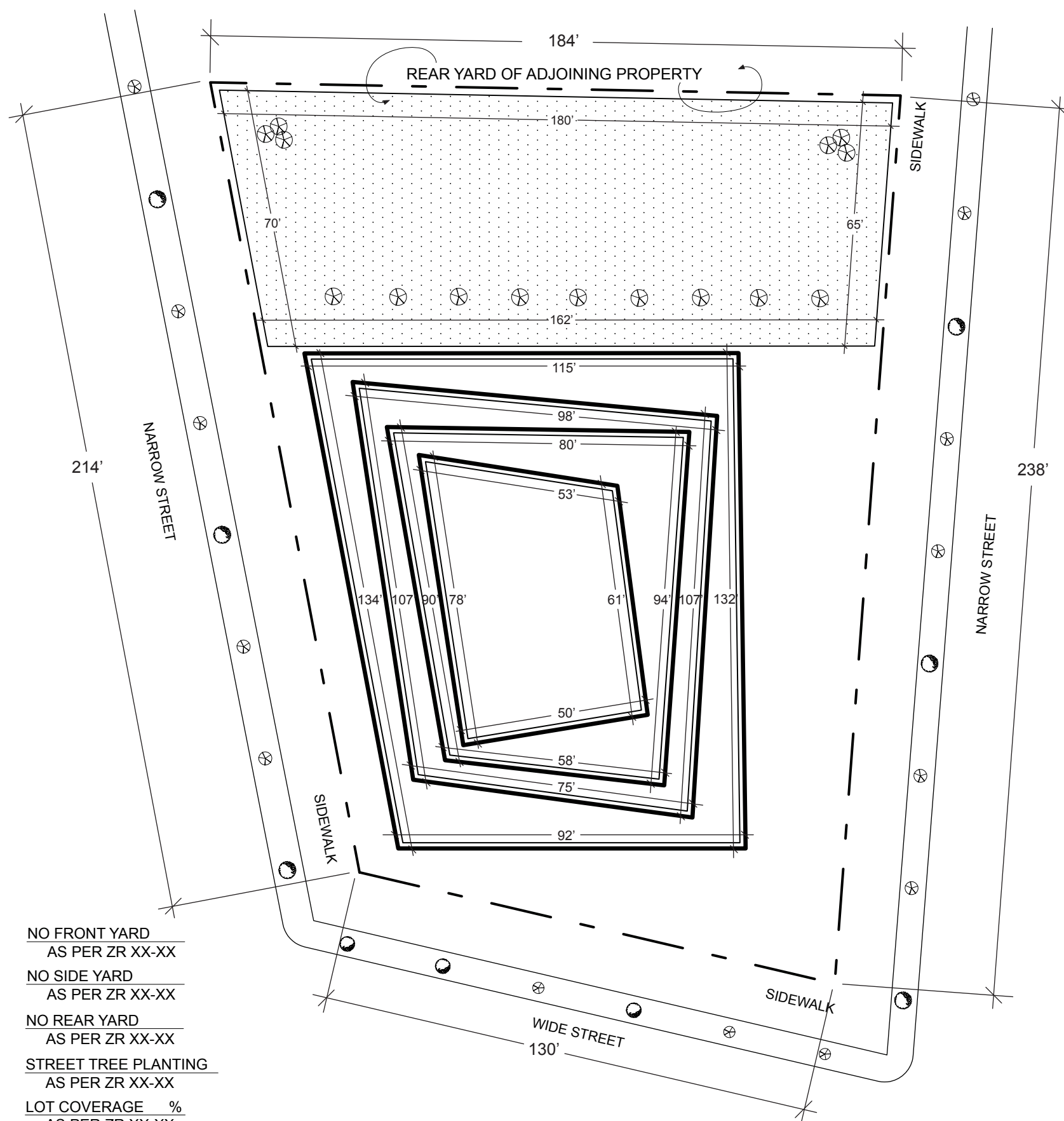

NO FRONT YARD
AS PER ZR XX-XX

NO SIDE YARD
AS PER ZR XX-XX

NO REAR YARD
AS PER ZR XX-XX

STREET TREE PLANTING
AS PER ZR XX-XX

LOT COVERAGE %
AS PER ZR XX-XX

LOT AREA SQ. FT.

LEGEND

C5-3
URBAN PLAZA FAR BONUS



ZONING LOT LINE



MAXIMUM BUILDING ENVELOPE



AXONOMETRIC DIAGRAM

NOT TO SCALE

540' BUILDING HEIGHT
AS PER ZR XX-XX

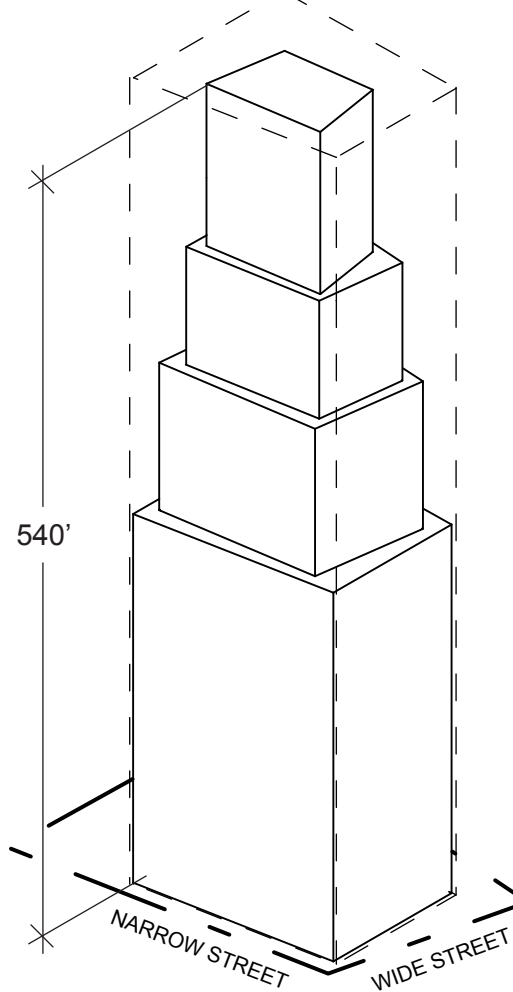

SECTION DIAGRAM

NOT TO SCALE

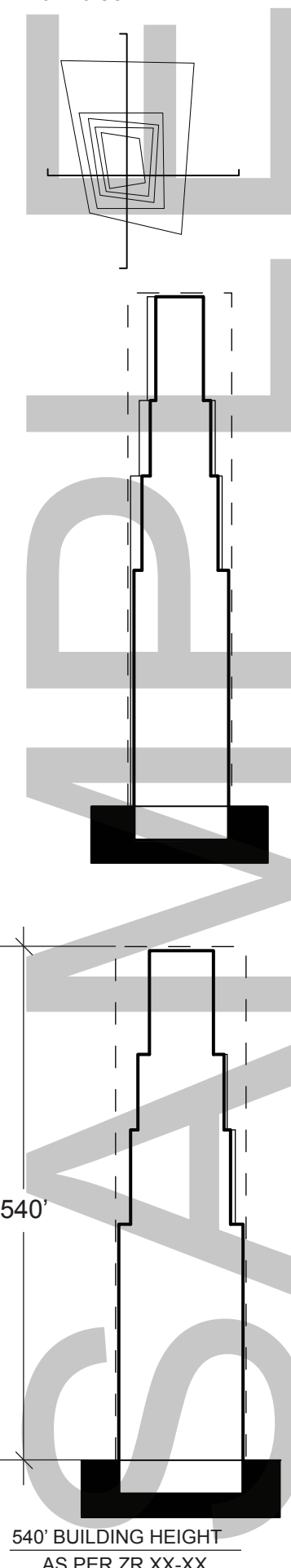

540' BUILDING HEIGHT
AS PER ZR XX-XX



ZD1 Zoning Diagram

Must be typewritten.

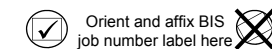

Submitted to resolve objections stated in a notice of intent to revoke issued pursuant to rule 101-15.

Yes No

Location Information

House No(s) _____
 Street Name _____
 Borough _____
 Block _____
 Lot _____
 BIN _____

Falsification of any statement is a misdemeanor and is punishable by a fine or imprisonment, or both. It is unlawful to give to a city employee, or for a city employee to accept, any benefit, monetary or otherwise, either as a gratuity for properly performing the job or in exchange for special consideration. Violation is punishable by imprisonment or fine or both. I understand that if I am found after hearing to have knowingly or negligently made a false statement or to have knowingly or negligently falsified or allowed to be falsified any certificate, form, signed statement, application, report or certification of the correction of a violation required under the provisions of this code or of a rule of any agency, I may be barred from filing further applications or documents with the Department.

NAME (PLEASE PRINT) _____

SIGNATURE _____ DATE _____

P.E./A. SEAL (APPLY SEAL; SIGN AND DATE OVER SEAL)

Internal Use Only

BIS Doc # _____

PLAN EXAMINERS SIGN AND DATE

